



This is a digital copy of a book that was preserved for generations on library shelves before it was carefully scanned by Google as part of a project to make the world's books discoverable online.

It has survived long enough for the copyright to expire and the book to enter the public domain. A public domain book is one that was never subject to copyright or whose legal copyright term has expired. Whether a book is in the public domain may vary country to country. Public domain books are our gateways to the past, representing a wealth of history, culture and knowledge that's often difficult to discover.

Marks, notations and other marginalia present in the original volume will appear in this file - a reminder of this book's long journey from the publisher to a library and finally to you.

### **Usage guidelines**

Google is proud to partner with libraries to digitize public domain materials and make them widely accessible. Public domain books belong to the public and we are merely their custodians. Nevertheless, this work is expensive, so in order to keep providing this resource, we have taken steps to prevent abuse by commercial parties, including placing technical restrictions on automated querying.

We also ask that you:

- + *Make non-commercial use of the files* We designed Google Book Search for use by individuals, and we request that you use these files for personal, non-commercial purposes.
- + *Refrain from automated querying* Do not send automated queries of any sort to Google's system: If you are conducting research on machine translation, optical character recognition or other areas where access to a large amount of text is helpful, please contact us. We encourage the use of public domain materials for these purposes and may be able to help.
- + *Maintain attribution* The Google "watermark" you see on each file is essential for informing people about this project and helping them find additional materials through Google Book Search. Please do not remove it.
- + *Keep it legal* Whatever your use, remember that you are responsible for ensuring that what you are doing is legal. Do not assume that just because we believe a book is in the public domain for users in the United States, that the work is also in the public domain for users in other countries. Whether a book is still in copyright varies from country to country, and we can't offer guidance on whether any specific use of any specific book is allowed. Please do not assume that a book's appearance in Google Book Search means it can be used in any manner anywhere in the world. Copyright infringement liability can be quite severe.

### **About Google Book Search**

Google's mission is to organize the world's information and to make it universally accessible and useful. Google Book Search helps readers discover the world's books while helping authors and publishers reach new audiences. You can search through the full text of this book on the web at <http://books.google.com/>

the 1990s, the number of people in the UK who are employed in the public sector has increased from 1.5 million to 2.5 million. The public sector has become a major employer in the UK, and this has implications for the way in which the public sector is managed and the way in which it is funded.

The public sector is a complex and diverse organisation, and it is difficult to define it precisely. However, it is generally understood to include the following: the central government, the local authorities, the health service, the education system, and the social services. The public sector is a major employer in the UK, and it is also a major consumer of goods and services.

The public sector is a major employer in the UK, and it is also a major consumer of goods and services. The public sector is a complex and diverse organisation, and it is difficult to define it precisely. However, it is generally understood to include the following: the central government, the local authorities, the health service, the education system, and the social services.

The public sector is a major employer in the UK, and it is also a major consumer of goods and services. The public sector is a complex and diverse organisation, and it is difficult to define it precisely. However, it is generally understood to include the following: the central government, the local authorities, the health service, the education system, and the social services.

The public sector is a major employer in the UK, and it is also a major consumer of goods and services. The public sector is a complex and diverse organisation, and it is difficult to define it precisely. However, it is generally understood to include the following: the central government, the local authorities, the health service, the education system, and the social services.

The public sector is a major employer in the UK, and it is also a major consumer of goods and services. The public sector is a complex and diverse organisation, and it is difficult to define it precisely. However, it is generally understood to include the following: the central government, the local authorities, the health service, the education system, and the social services.

The public sector is a major employer in the UK, and it is also a major consumer of goods and services. The public sector is a complex and diverse organisation, and it is difficult to define it precisely. However, it is generally understood to include the following: the central government, the local authorities, the health service, the education system, and the social services.

The public sector is a major employer in the UK, and it is also a major consumer of goods and services. The public sector is a complex and diverse organisation, and it is difficult to define it precisely. However, it is generally understood to include the following: the central government, the local authorities, the health service, the education system, and the social services.



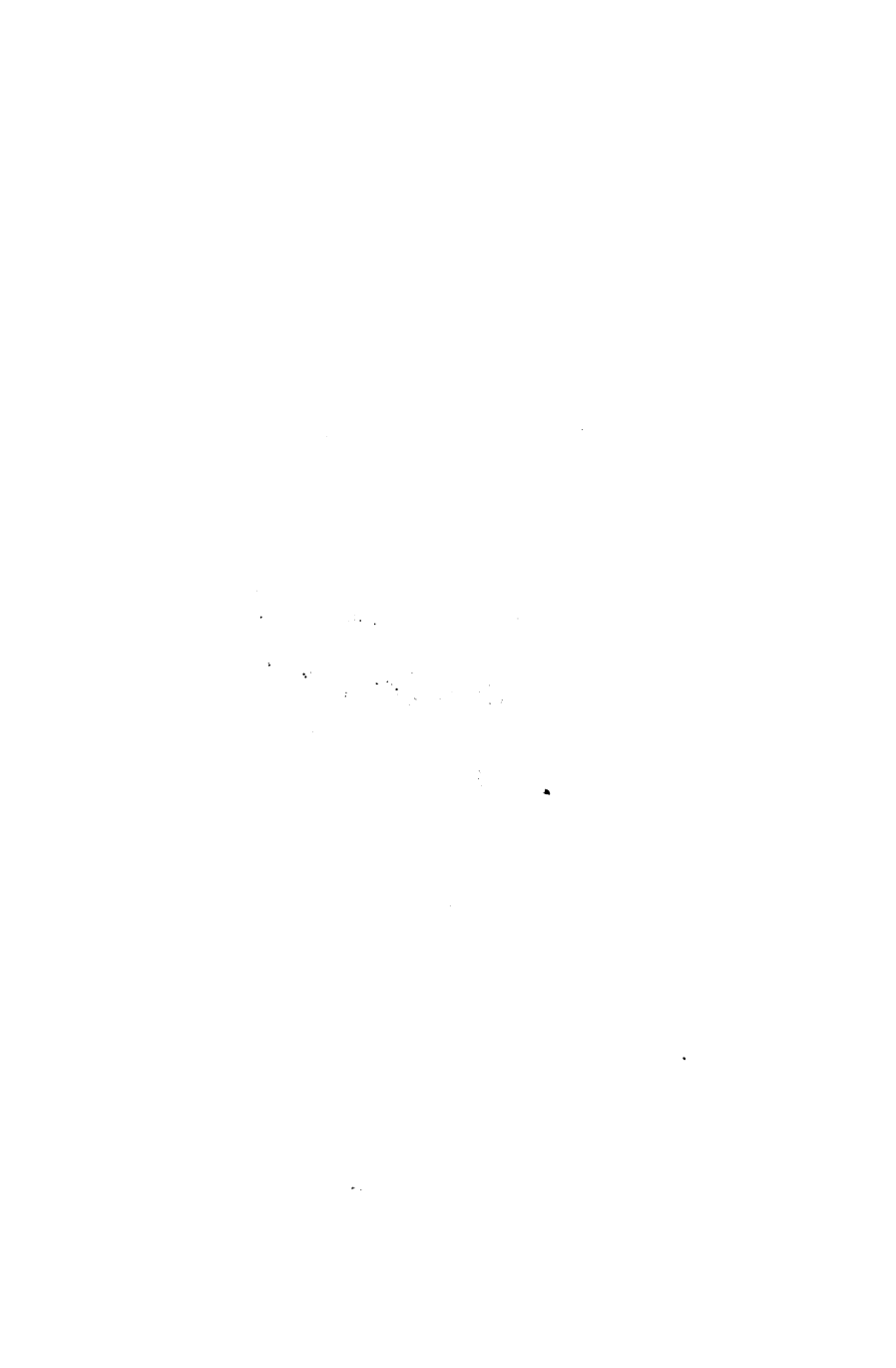



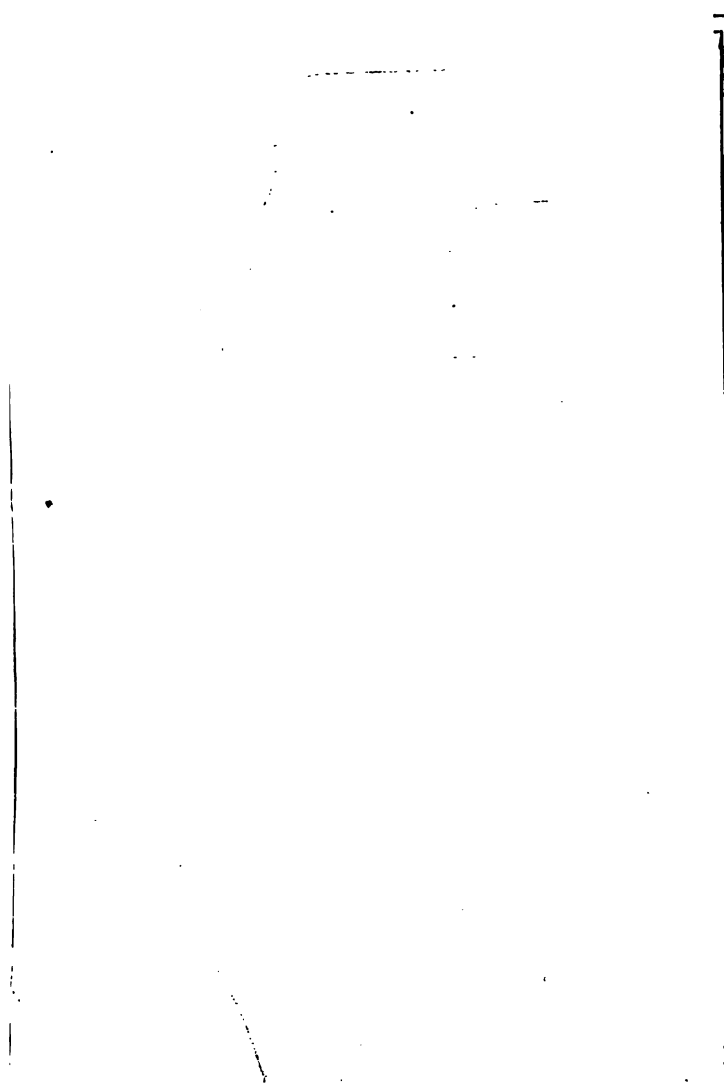

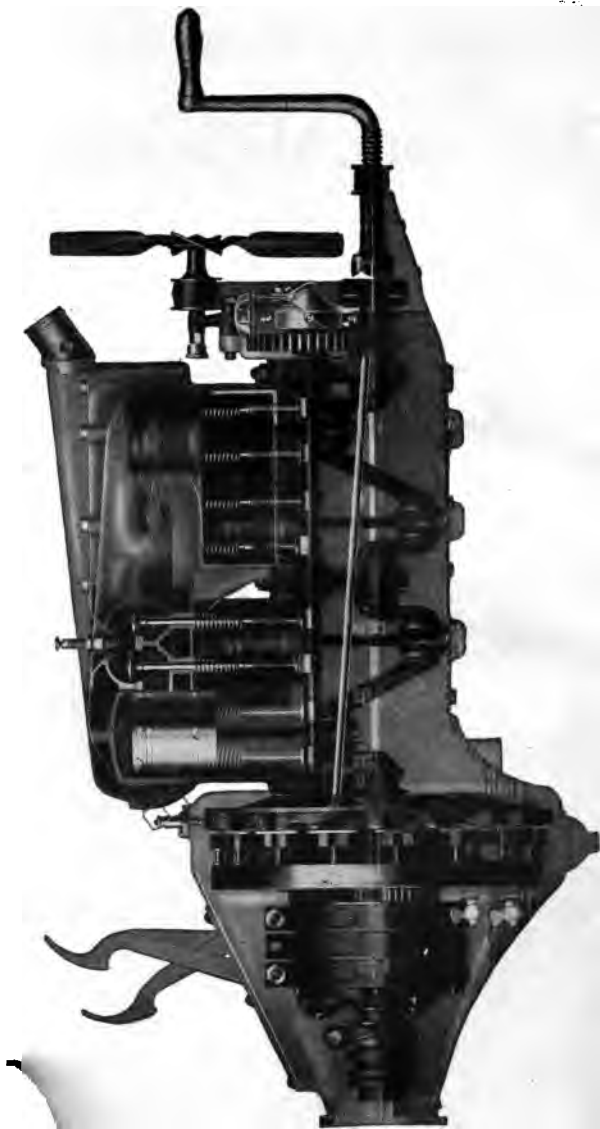

The Ford Power Plant.

# The Ford Motor Car

—AND—

## Truck and Tractor Attachments

*Their Construction, Care and Operation*

By

HAROLD P. MANLY

Author of "Automobile Starting and Lighting," "Oxy-Acetylene Welding and Cutting, Electric and Thermit Welding," and Editor of Revised Edition of "Brookes' Automobile Handbook"

—  
FULLY ILLUSTRATED  
—

CHICAGO

FREDERICK J. DRAKE & CO.

Publishers





7  
1  
7

Emy  
TL  
215  
,F7  
M29



Copyright 1917  
By Frederick J. Drake & Co.  
Chicago





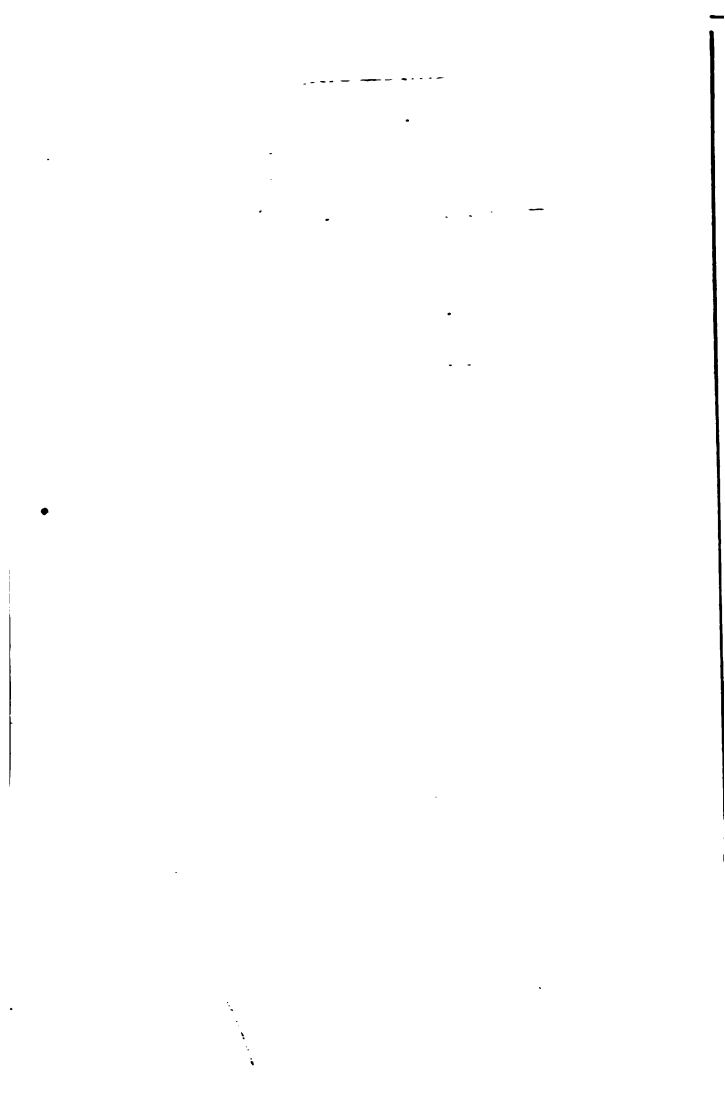

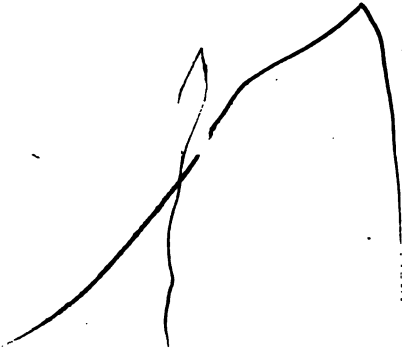

# THE FORD MOTOR CAR

---

## CHAPTER I

### THE FORD POWER PLANT

When liquid gasoline is turned to a vapor or gas and mixed with air the mixture burns very easily. If this gasoline and air vapor is compressed into a small space it will ignite and burn so rapidly that the action is like an explosion. While burning, this mixture increases in volume and the resulting pressure is made to do the work of driving the car.

In order to use the force of this explosive burning the mixture of gasoline vapor and air is placed in the cylinder of an engine. The upper end of this cylinder is closed and the lower end is open as shown in Figure 1. In the lower end is a piston which makes a gas tight fit in the cylinder, yet slides freely from end to end. The burning mixture drives the piston down toward the open end of the cylinder and this motion of the piston turns a shaft from which is secured power to turn the wheels.

Attached to the engine is a device called a carburetor which turns the liquid gasoline into a vapor and mixes this vapor with the proper amount of air to make a combustible mixture.

To set fire to the gas an electric spark is caused to jump between two metal points inside of the engine cylinder, and in jumping through the mixture this spark ignites the gas.

With the engine running, the great heat of the burning gas would be sufficient to destroy the lubri-

the work: The Ford Power Plant; Transmission System; Driving and Control; Upkeep and Care; Power Plant Repair; Transmission and Running Gear Adjustments; Troubles, Symptoms and Remedies; Electric Starting and Lighting; Truck and Tractor Attachments.

Every part of the book is fully illustrated and those who desire to study deeper into the electrical principles involved in the ignition and starting and lighting systems, will find wiring diagrams which will prove of great assistance. Valuable information in regard to tires and their repair has been included.

The author desires to express his thanks to the Engineers of the Ford Motor Company for assistance in the preparation of the work and especially for allowing the use of many of their original drawings and designs from which the illustrations for this book have been made. It is doubtful if such a thorough and authoritative presentation of the subject could have been made without their assistance.

THE AUTHOR.

# CONTENTS

	PAGE
CHAPTER I	
THE FORD POWER PLANT.....	9
CHAPTER II	
THE FORD TRANSMISSION SYSTEM.....	52
CHAPTER III	
DRIVING AND CONTROL.....	77
CHAPTER IV	
UPKEEP AND CARE.....	105
CHAPTER V	
POWER PLANT REPAIR.....	125
CHAPTER VI	
TRANSMISSION AND RUNNING GEAR ADJUSTMENTS.....	156
CHAPTER VII	
TROUBLES, SYMPTOMS AND REMEDIES.....	175
CHAPTER VIII	
ELECTRIC STARTING AND LIGHTING.....	204
CHAPTER IX	
TRUCK AND TRACTOR ATTACHMENTS.....	235
INDEX .....	253





# THE FORD MOTOR CAR

---

## CHAPTER I

### THE FORD POWER PLANT

When liquid gasoline is turned to a vapor or gas and mixed with air the mixture burns very easily. If this gasoline and air vapor is compressed into a small space it will ignite and burn so rapidly that the action is like an explosion. While burning, this mixture increases in volume and the resulting pressure is made to do the work of driving the car.

In order to use the force of this explosive burning the mixture of gasoline vapor and air is placed in the cylinder of an engine. The upper end of this cylinder is closed and the lower end is open as shown in Figure 1. In the lower end is a piston which makes a gas tight fit in the cylinder, yet slides freely from end to end. The burning mixture drives the piston down toward the open end of the cylinder and this motion of the piston turns a shaft from which is secured power to turn the wheels.

Attached to the engine is a device called a carburetor which turns the liquid gasoline into a vapor and mixes this vapor with the proper amount of air to make a combustible mixture.

To set fire to the gas an electric spark is caused to jump between two metal points inside of the engine cylinder, and in jumping through the mixture this spark ignites the gas.

With the engine running, the great heat of the burning gas would be sufficient to destroy the lubri-

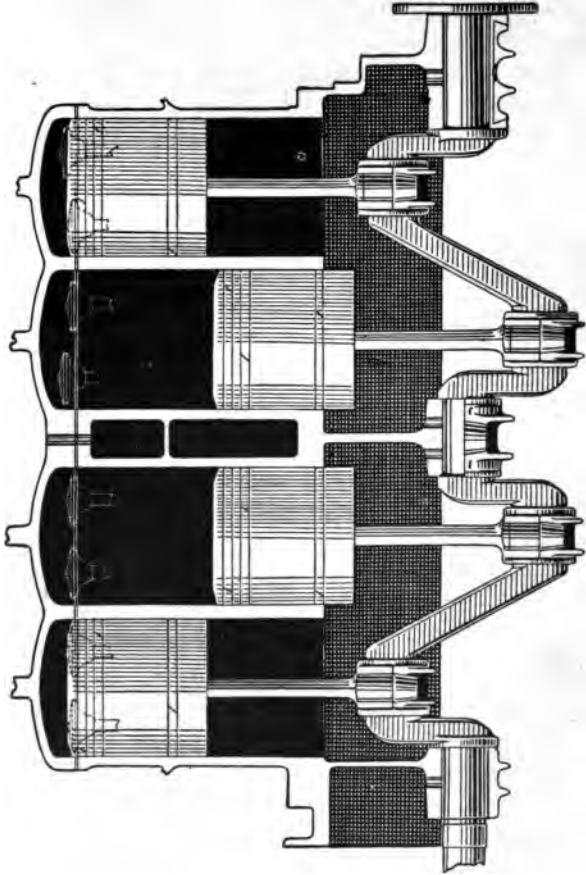

Figure 1.—Relation of Pistons and Crankshaft in the Ford Engine.

cating oil which is necessary to insure smooth running of the mechanism. To preserve the oil against such destruction, the cylinder is surrounded with water and by means of this water excess heat is carried away and dissipated into the outside air.

The Ford car may be divided, for convenience of explanation, into five parts. With one of these parts, the body, we are not concerned to such a great extent as with the remaining four which, taken together, are called the chassis.

The chassis is composed of the power plant, the drive system, the running gear and the control. The power plant includes the engine and all the parts that make or help to make power. It is that part of the car located ahead of the dash and underneath the engine hood. The drive system includes all of the parts that receive power and deliver it to the driving wheels. These parts extend from the rear end of the power plant back to the wheels and underneath the body. The running gear includes all of the parts that support and carry the first two divisions of the chassis as well as the car body. The control includes all of the parts that allow the driver to make the car start or stop, to turn around or go faster or slower. Each of these principal units is made up of smaller parts whose disposition in the chassis is shown in Figure 2.

#### THE ENGINE

The mixture of gasoline and air furnished by the carburetor passes into the space left between the top of the piston and the closed end, or head, of the cylinder. The spark then sets fire to the gas and expansion takes place with the burning. This expansion pushes

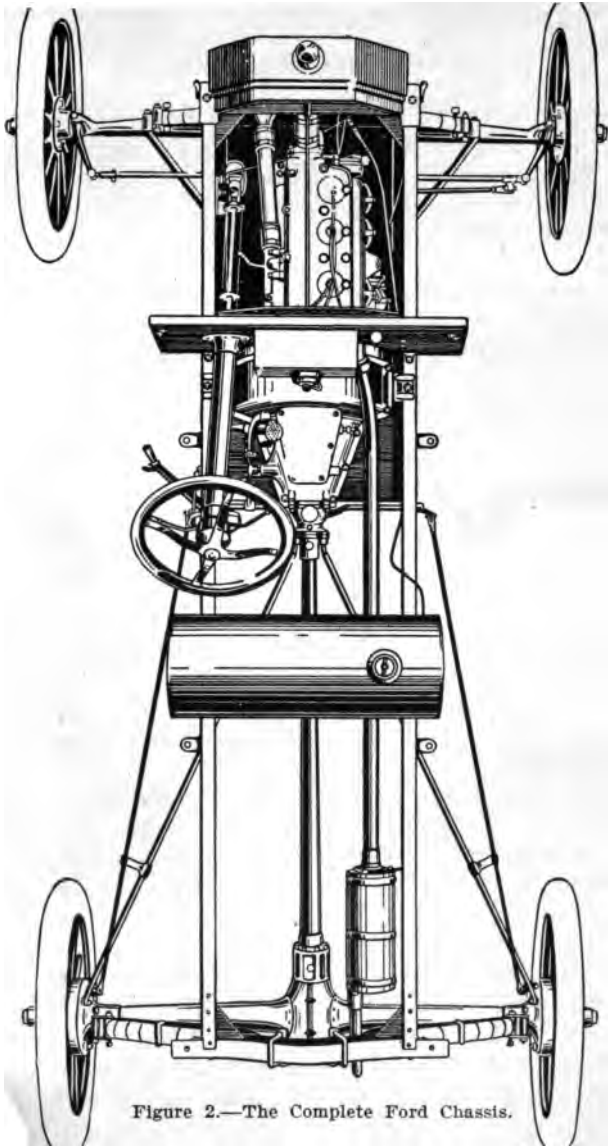

Figure 2.—The Complete Ford Chassis.

the piston toward the lower end of the cylinder, and if there were no parts to prevent it, the piston would be forced completely out of the open end.

To prevent the piston from leaving the cylinder a steel pin is passed through the piston walls from one side to the other. A long straight rod with a bearing at each of its ends is attached to the steel pin at the top and to a crank below. When the piston moves away from the closed end of the cylinder it pushes on

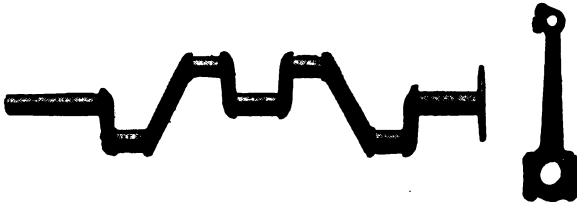

Figure 3.—Crankshaft and Connecting Rod.

the rod and the crank is turned. The crank is attached to a shaft and the up and down motion of the piston is changed to a rotary motion of the shaft. This long connecting rod and the crankshaft are shown in Figure 3.

*Flywheel.*—The cylinder is closed at the upper end only and the piston receives power from the burning gas only on top. Therefore, a gasoline engine delivers power only while the piston is traveling down toward the open end of the cylinder.

In order to force the piston back into the cylinder so that another power stroke may be secured a heavy wheel is fastened to the rear end of the crankshaft. This wheel is called the flywheel. When the piston causes the crankshaft to turn, the flywheel is revolved. Much force of the burning gas goes into the work of

turning the flywheel, but when the piston comes to the end of its stroke, the flywheel is heavy enough and has momentum enough to keep on turning, and after the burned gas has been allowed to escape from the cylinder the flywheel turns the crankshaft and forces the piston up and back into the cylinder. Without a flywheel the engine would come to a stop as soon as the piston was as far down in the cylinder as it could go.

When the piston is pushed back into the cylinder it does not go all the way to the closed end or head, but leaves a little space above the top of the piston. This space holds the compressed mixture of gasoline and air and is called the combustion space.

*Piston Rings.*—After a gasoline engine had been run for some time the piston and cylinder would wear so that they would no longer make a gas tight fit. The gas would then escape between the piston and cylinder walls and the engine would no longer give its full power.

To prevent such leakage three grooves are cut around the outside of the piston walls and in each groove is placed a cast iron ring that fits snugly at all points. This ring is cut through on one side so that it will open enough to slip over the piston and drop into the groove. After the ring is in the groove it tends to spread or expand and when the piston with the rings in place is inserted into the cylinder the rings press out against the walls of the cylinder and make a gas tight fit.

There is one ring in each of three grooves or slots so that any gas escaping past the first ring will be stopped by others. The total escape of gas will therefore be so slow that the piston has time to make the full stroke without great loss.

Although one end of the cylinder is closed it is

necessary to provide some way for the mixture of fresh gas to get into the combustion space in this closed end, also for the burned gas to get out and make room for fresh gas. The gases pass into and out of the cylinder through valves.

At one side of the combustion space in the cylinder are two round holes. These holes are covered by cast iron disks and to each disk is fastened one end of a steel rod with the end of the rod in the exact center of the disk.

This form of valve is placed in the combustion space with the rod sticking down through the opening so that with the lower end of the rod pulled down the disk is held tightly over the hole and makes the combustion space gas tight. When gas is to pass into or out of the cylinder, the lower end of the rod is pushed up, thus forcing the disk away from the hole and opening the valve. One valve opens to let fresh gas into the cylinder and is called the inlet valve; the other lets burned gas out and is called the exhaust valve.

*Stroke and Revolution.*—When the piston moves from either end of the cylinder to the other end it has made one stroke; that is to say, from the top of the cylinder to the bottom is one stroke and from the bottom back to the top is another stroke.

The crankshaft and flywheel make one complete turn or revolution for two strokes of the piston. The piston makes one down-stroke and one up-stroke while the flywheel turns around once.

#### THE POWER ELEMENTS OF AN ENGINE

*Inlet Stroke.*—When the engine is to be started it is first necessary to fill the combustion space with fresh



gas. This is done by turning the crankshaft until the piston is as near the cylinder head as it will go, at which time the inlet valve opens. By turning the crankshaft still farther the piston is drawn back toward the lower end of the cylinder.

The hole which was closed by the inlet valve connects with a pipe that leads to the carburetor, and as the piston moves toward the lower end of the cylinder, it draws in a charge of fresh gas. The stroke that fills the cylinder with fresh gas is called the inlet stroke or the suction stroke.

*Compression Stroke.*—At the end of the inlet stroke, when the cylinder has received all the gas that it will hold, the inlet valve closes. At this time the exhaust valve is also tightly closed. The crankshaft continues to turn until the piston is for the second time forced back as near the cylinder head as it will go.

Since both valves are closed, the cylinder full of fresh gas is now compressed into the combustion space. When the gas is compressed it becomes highly inflammable and burns with generation of great pressure.

When the piston has been forced as near the cylinder head as it will go, a spark sets fire to the gas. The position of the piston in the cylinder when the gas is fired is called the firing point and the stroke that compressed the gas is called the compression stroke.

*Power Stroke.*—The gas now burns so fast that it is like an explosion and the resulting pressure drives the piston back toward the open end of the cylinder. The piston pushes on the connecting rod, the connecting rod turns the crankshaft and the crankshaft turns the flywheel. This stroke is called the power stroke.

During the inlet and compression strokes the crankshaft was turned by hand or by the starter to bring

the engine to the first power stroke. By turning the crankshaft the engine is made to go through the inlet and compression strokes and come to the firing point. As soon as the compressed gas begins to burn the piston makes the crankshaft turn faster than the operator or starter can turn it and a ratchet automatically releases the crankshaft. The momentum of the flywheel then keeps the engine running steadily until it reaches another power stroke.

*Exhaust Stroke.*—At the end of the power stroke, when the piston has moved as far as the connecting rod and crankshaft will let it go, no more work can be secured from the expanding gas, so the next thing to do is to get rid of the old gas and allow another change of fresh mixture to be drawn into the cylinder. In order to get rid of the burned gas the exhaust valve opens, and as the piston is forced back into the cylinder by the flywheel, it pushes the old gas ahead of it and out through the valve opening.

This stroke of the engine is called the exhaust stroke and it ends when the piston is as near the cylinder head as it will go. The piston is then in a position to start another inlet stroke and the engine repeats the same series of operations as long as it continues to run.

*The Four-Cycle Engine.*—There is but one of the four strokes in any one cylinder which delivers power to the crankshaft. The crankshaft and the flywheel turn around twice for each power stroke because the full turn of the crankshaft makes the piston move away from the cylinder head on the inlet stroke and back on the compression stroke, while the next full turn of the crankshaft lets the piston move away from the cylinder head on the power stroke and back on the exhaust stroke.

There are four strokes, the inlet, the compression, the power and the exhaust, and these strokes are then repeated over and over again in the same regular order.

Any series of events that happens in a regular order and then repeats in the same order is called a cycle. The four strokes of the engine form a cycle and this type of engine is called a four-cycle engine or a four-stroke cycle engine.

#### VALVES

The type of valve used in the Ford engine is called a poppet valve and in the form adopted the edge of the valve and that part of the cylinder into which it fits are tapered so that as the valve closes it drops easily into place. The rod to which the valve head is attached is called the valve stem and the stem moves through a guide which brings the head onto its seat so that a good fit is insured.

In order that the valve may be easily mounted, the cylinders are made with extensions or pockets at one side of the combustion space. These pockets are just large enough to take the valve head and allow it to move.

The valves must open and close at exactly the right time during the movement of the piston and the rotation of the crankshaft. The poppet from off valve is opened by means of a cam which is a small piece of steel that is higher on one side than on the other. One cam for each of the valves is fastened to a shaft so that all the cams may be turned while the lower end of the valve stems rest on the cams. As the cam turns the stem of the valve is raised whenever the high side of the cam comes around. As the high side of

the cam passes away from underneath the valve stem the valve is pulled closed by a spring.

The shaft that carries the cams is revolved by means of a pair of gears, one of which is fastened to the camshaft and the other to the crankshaft of the engine. The camshaft is mounted directly underneath the valve stems. All of the parts are shown in Figure 4.

*Valve Action.*—There are two strokes during each full turn of the flywheel and in any one cylinder there must be a total of four strokes for each power impulse. There must be an exhaust stroke, an inlet stroke, a compression stroke and finally a power stroke.

The exhaust valve must open during the exhaust stroke and the inlet valve must open during the inlet stroke. After one exhaust stroke or one inlet stroke the flywheel must make two complete revolutions before another exhaust stroke or another inlet stroke takes place in the cylinder being considered.

That means that the camshaft must turn at a rate such that the exhaust cam will raise the exhaust valve and the inlet cam raise the inlet valve every second turn of the crankshaft.

In order to do this the camshaft must turn just half as fast as the crankshaft so that the crankshaft may complete two full turns while the camshaft turns once. This will bring the high side of a cam under its valve every second time that the crankshaft and flywheel turn completely around. To provide this ratio the gear on the camshaft is made just twice as large and has just twice the number of teeth that the crankshaft gear has.

The parts that open the valves are the timing gears, the camshaft and the cams. The valves are closed by



Figure 4.—Valve Operating Parts of the Ford Engine.

coiled springs having one end of the spring attached to the lower end of the valve stem and the other pressed against the cylinder.

If a cam pushed directly on the bottom of the stem to open a valve it would of course push sidewise as well as up. This side thrust would tend to bend the stem, and, even if the stem did not bend, a great deal of friction and wear would be caused. To get away from this wear and side thrust, the lower end of the valve stem does not rest directly on the cam but is operated through push rods or valve lifters.



Figure 5.—Valve and Valve Push Rod.

A push rod is a piece of steel about four inches long set into a guide so that it can slide up and down. The end of the valve stem rests on the upper end of the push rod so that when the cam raises the rod, the rod in turn raises the valve. These parts are shown in Figure 5.

*The Four-Cylinder Engine.*—It will be noted that in the engine as described up to this point we have but one power stroke for two revolutions of the crankshaft and that the remaining three strokes consume power. It will readily be seen that a considerable space of time would elapse in a single-cylinder engine between successive power strokes and unless a very heavy flywheel were used, the engine would not run smoothly and would have to be of great size to develop sufficient power for the work of driving a car.

These difficulties are overcome by providing four cylinders which operate on one crankshaft and with one flywheel. The power strokes occur at such times during the revolution of the crankshaft that one or the other of the four cylinders is delivering power during each half revolution of the shaft.

In a four-cylinder engine of the four-cycle type the cranks are set on the crankshaft so that two pistons

	1st ½ Revolution	2nd ½ Revolution	3rd ½ Revolution	4th ½ Revolution
#1 Cylinder	↓ Power	↑ Exhaust	↓ Inlet	↑ Compression
#2 Cylinder	↑ Compression	↓ Power	↑ Exhaust	↓ Inlet
#3 Cylinder	↑ Exhaust	↓ Inlet	↑ Compression	↓ Power
#4 Cylinder	↓ Inlet	↑ Compression	↓ Power	↑ Exhaust

Figure 6.—The Relation of the Strokes in the Cylinders.

are up while the other two are down, and while the first two are traveling down the other two travel up.

One of the two down-going pistons is on its inlet stroke while the other is on its power stroke. Of the two pistons that are traveling up, one is making a compression stroke and the other an exhaust stroke. The strokes in each of the four cylinders occur as shown in the accompanying chart, Figure 6. It will be seen that during the first half revolution of the crankshaft cylinder number one, which is toward the front of the car, is making a power stroke, cylinder

number two is on compression, number three on exhaust, and number four on the inlet stroke. During the second half revolution, cylinder number two is firing while the remaining cylinders are making the other three strokes. On the third half revolution cylinder number four fires and on the fourth half revolution cylinder number three fires and the engine is then ready to repeat the cycle in each of the four cylinders. It will be seen that the cylinders fire in the order of number one, then number two, then number four, and then number three. This order, 1-2-4-3, is called the firing order of the engine.

By rearranging the cams it is also possible to cause a four-cylinder engine to fire in the order of 1-3-4-2, but no other firing orders are possible without changing the crankshaft and thereby destroying the mechanical balance of the engine. The arrows in the squares of the chart indicate the direction of piston travel during each stroke in any one cylinder. Reading from left to right it is seen that the piston moves up and down alternately. The movement during any half revolution, which is read from top to bottom in any one of the columns, shows that two pistons are moving down while the remaining two move up and that number one and number four travel together, while number two and number three form another pair.

*The Muffler.*—At the end of the power stroke and when the exhaust valve opens, the pressure of the burning gas in the cylinder may be as high as eighty to ninety pounds to the square inch, and this pressure when suddenly released by the opening of the valve makes a loud report which would be very objectionable if allowed to escape directly into the air. In order to prevent noise the gas is allowed to expand before it



finally passes away from the power plant. This expansion takes place in the muffler, which is composed of a series of passages, as shown in Figure 7.

The burning gas passes from the several cylinders into a pipe called the exhaust manifold, and from this pipe to another one which leads back to the muffler proper. As the gas travels through these pipes it cools and expands so that when it finally issues from the muffler it does so in a steady stream at low pressure and with very little noise.



Figure 7.—The Ford Muffler.

#### FORD ENGINE CONSTRUCTION

An examination of the construction of the Ford power plant shows some interesting features. Among the most noticeable of these is the fact that all four cylinders are made in one piece for the sake of rigidity and prevention of misalignment in reassembling.

The cylinder heads are formed of a separate casting, and this casting is bolted to the top of the cylinder proper. Removal of this head exposes the interior of the cylinders, the tops of the pistons and all of the valves, as well as the passages for the cooling water.

The lower part of the engine is enclosed by a sheet metal pan, Figure 8, which extends from the starting crank back underneath the engine, transmission and clutch as far as the universal joint. There are large

openings through this pan at a point underneath the cylinders, and by removing the cover plate which normally closes the opening, the crankshaft and the bearings at the lower end of the connecting rods are exposed.

The Ford power plant is secured to the car frame at three points. Two of these points are at opposite sides of the engine and the third one is at the forward end



Figure 8.—Lower Half of Engine Crankcase.

of the crankshaft. This front support is in the form of a bearing so that any twisting of the frame serves only to move the bearing and does not affect the engine or power plant. This principle of flexible three-point support is found throughout the Ford car.

#### CARBURETOR AND FUEL SYSTEM

The carburetor is a device by means of which liquid gasoline is turned into a vapor and this vapor mixed with a definite quantity of air. The type of instrument being used on the Ford cars is illustrated in Figure 9, and the following description will explain its workings.

Liquid gasoline flows from the tank through the feed pipe and enters the carburetor through the float valve. The float valve is carried at one end of an arm and on the other end of this arm is a circular piece of cork which has been shellaced so that it is impervious to gas-



Figure 9.—The Ford Carburetor.

oline. Between the float and the valve is a pin upon which the arm hinges. The tank construction is shown in Figure 10.

When the fuel chamber of the carburetor is empty the float will fall and the float valve will be raised. With the valve thus opened the liquid gasoline flows into the float chamber until it reaches such a height that the float is raised and the valve lowered to a point so that it closes and shuts off the admission of fuel.

Pure air enters the carburetor and passes through a U-shaped tube, then past the throttle valve into the intake manifold and thence through the intake valves to the cylinders.



Figure 10.—Fuel Tank and Sediment Trap.

Whenever a piston is ready to start down on the inlet stroke the corresponding inlet valve opens. The passage leading from the inlet valve communicates with the intake manifold and through the manifold with the carburetor. The suction created in the cylinder by the piston moving down from the cylinder head draws air through the carburetor.

The lowest point in the U-shaped passage is smaller in area than the other parts of the inlet openings and air passing this point is therefore traveling at a comparatively high rate of speed. At this lowest point is an opening from the fuel chamber into the air passage and the size of this opening is regulated by a needle valve. This opening is called the nozzle.

As air passes the nozzle it acts in much the same way as would air in an atomizer. A small quantity

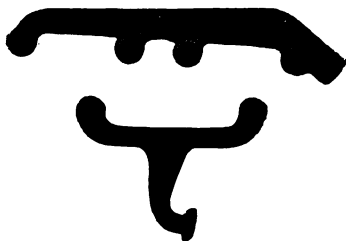

Figure 11.—Exhaust and Inlet Manifolds.

of liquid gasoline is drawn through the nozzle and issues into the stream of air. The speed at which the air is traveling, combined with the fact that the liquid gasoline is drawn from the nozzle in a fine stream and at right angles to the flow of air, causes the liquid to be broken up into very fine particles and these particles quickly turn to vapor and mix with the incoming air. The proportion of gasoline to the amount of air is determined by the adjustment of the needle valve. The proportion of gasoline is lessened by turning the needle valve down or to the right, and is increased by turning the valve in the opposite direction.

After the air has passed the nozzle the proportion of gasoline vapor to air has been determined, but the

quantity of mixture passing to the cylinders may be varied by moving the throttle valve. This throttle valve is placed between the carburetor and the inlet manifold and is controlled by a lever underneath the steering wheel.

At the opening of the carburetor, through which fresh air enters, is a second valve, and to this valve is attached a rod, or wire, extending forward to a point in front of the radiator, so that while the engine is being cranked this valve may be partially or wholly closed. With this valve closed only a comparatively small amount of air can enter the carburetor and the suction is, therefore, greater. This suction draws a large amount of gasoline through the nozzle opening, and the excess of fuel makes engine-starting easy.

*Carburetor Adjustment.*—There is but one adjustment provided for a Ford carburetor, this being the amount of liquid fuel as controlled by the needle valve. The needle valve may be turned one way or the other by means of a handle or knob on the dashboard of the car, and just at the right of the coil box. The appearance of one type of adjustment is shown in Figure 12.

Turning this dash adjustment to the right or in a clockwise direction closes the needle valve of the carburetor, and turning the dash adjustment to the left opens the needle valve. This adjustment may be changed while the car is running on the road, and it will be found best to make a mark at some point on the adjustment to indicate the position at which the engine runs best. In cold weather it will probably be necessary to turn the adjustment about one-quarter turn to the left, which will furnish more gasoline. In warm weather the gasoline vaporizes with greater

and it is an economy to reduce the quantity of liquid fuel by turning the adjustment to the right as far as possible without reducing the speed of the engine for a given throttle opening.

An excess of gasoline in proportion to the amount of air in the mixture gives what is called a rich mixture. Too little gasoline gives a lean mixture. Too rich a mixture will cover the interior of the engine

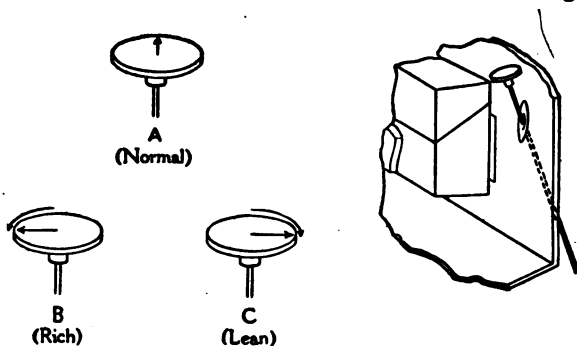

Figure 12.—Dash Adjustment for Carburetor.

and the tops of the valves with soot or carbon, and will also cause over-heating. A rich mixture may cause misfiring at low speeds, and yet the machine may run perfectly at high speed. It is, therefore, better to keep the mixture as lean as possible without sacrificing the power of the engine.

A lean mixture burns slowly and for this reason such a mixture may continue to burn all through the exhaust stroke, and until the inlet valve again opens. Under such conditions the fresh gas in the inlet manifold will be ignited by the burning, as in the cylinder, resulting in what is called a backfire into the carbu-

retor. This is dangerous and may easily result in a fire, should there be much grease or oil around the carburetor.

Carburetor adjustment is rendered easier and free from the necessity of frequent change if a hot air tube is used which takes air from around the exhaust pipe and leads it to the carburetor. The heated air helps to vaporize the liquid fuel and this pipe should be used during cold weather. It is permissible and sometimes an advantage to remove the hot air pipe during warm weather.

It is noticed by experienced drivers that an engine will almost invariably operate better after sundown or on a foggy, moist day. This condition is due to the slight amount of moisture in the air which is introduced with the mixture.

Many attempts have been recently made to reproduce these favorable conditions by the introduction of water vapor into the fuel system at some point between the carburetor and the engine.

The fuel supply for the Ford car is carried in a tank of ten gallons capacity, located under the front seat, and mounted on the frame of the car. From the tank the fuel passes through a stop cock, which may be closed to prevent any possibility of leaking when the car is to be unused for some time. Below the stop cock is a sediment bulb, and on the bottom of this bulb is a drain cock. The purpose of this bulb is to prevent the passage of water, or any solid impurities, from the tank to the carburetor. Water, as well as other impurities, is heavier than gasoline and will, therefore, sink to the bottom of the bulb and remain there. The drain cock should be opened at intervals of about one week and any dirt or moisture allowed to flow



away. A screen is placed at the opening from the sediment bulb to the fuel pipe and in case of a more or less complete stoppage of the fuel supply this screen should be examined and cleaned.

The fuel tank is of cylindrical section and it will, therefore, be found that the depth of gasoline, as measured on a stick, may be somewhat confusing. The tank is ten and one-quarter inches deep, and while the fuel level shows a little more than one-fourth of this distance on a depth gage, the tank is only one-fifth full. The following table will be found convenient if marked off on a piece of wood to be used for measuring the quantity of fuel in the tank:

1	17/32 inches corresponds to	1 gallon
2	9/16 inches corresponds to	2 gallons
3	1/2 inches corresponds to	3 gallons
4	11/32 inches corresponds to	4 gallons
5	1/8 inches corresponds to	5 gallons
5	29/32 inches corresponds to	6 gallons
6	3/4 inches corresponds to	7 gallons
7	11/16 inches corresponds to	8 gallons
8	23/32 inches corresponds to	9 gallons
10	1/4 inches corresponds to	10 gallons

#### THE FORD IGNITION SYSTEM

The Ford ignition system is entirely different from that found on any other car. It consists of five parts: the magneto which generates the electric current; the induction coil which changes the voltage or pressure of this current to one of sufficient intensity to jump the gap in the cylinder; the commutator which determines the time at which the spark occurs; the spark plugs which carry the points between which the spark

passes, and the wiring system which carries the current between the different parts.

*The Ford Magneto.*—The Ford magneto is a generator which produces an alternating flow of electric current. This means that the current passes through the wires first in one direction and then the other. These changes of direction occur with great rapidity, the rate at ordinary car speed being about 16,000 changes a minute. Ordinary lighting generators produce a direct current; that is, one in which the flow is always in the same direction.

That value of an electric current which corresponds to pounds to the square inch in measuring water power is called voltage, and a current has strength to pass through an air gap in proportion to the voltage of the current.

The current made by the Ford magneto is of comparatively low pressure, ranging between eight and sixteen volts under ordinary conditions. This voltage would not be sufficient to jump between the points of the spark plug and it is therefore necessary to pass the magneto current through coils which raise the voltage many hundred times so that a good spark is provided for setting fire to the mixture. These coils are carried on the dash.

The Ford magneto consists essentially of but the two parts shown in Figure 13. One of these parts is a set of sixteen V-shaped permanent magnets mounted on the flywheel of the engine and the other part consists of a set of sixteen electromagnets which remain stationary and in such a position that the flywheel magnets pass very close to the electromagnets while the engine is running.

An electromagnet is made up of a piece of soft iron

around which is wound a wire or ribbon of some good electrical conductor such as copper. This wire or ribbon is insulated with a substance which resists the passage of electricity so that the flow of current will be around the iron, but not through it. Whenever



Figure 13.—Permanent and Electromagnets in Magneto.

an electromagnet is moved so that it comes close to and then recedes from a permanent magnet or other source of magnetism a flow of current is induced through the conductor which is wound around the iron or core of the electromagnet. The same result is obtained by moving a permanent magnet so that it alternately comes close to and then moves away from an electromagnet.

The Ford magneto is so constructed that the ends of the permanent magnets, from which the flow of magnetism is strongest, are caused to pass directly across the ends of the stationary magnets so that in one position of the flywheel the ends of the permanent magnets are directly in front of the ends of the electromagnets. When the flywheel revolves the permanent magnets pass from in front of the electromagnets to a point midway between them. Then, with continued rotation the magnets are again brought into direct line.

This action continues as long as the engine runs and the movement of the two sets of magnets in relation to each other produces a flow of alternating current in the conductor which is wound in one continuous length around all of the sixteen electromagnets.

One end of the winding of the electromagnets is attached to the metal of the engine while the other end leads to a terminal or binding post which appears on top of the flywheel housing and directly back of the fourth cylinder of the engine. Should a metallic connection be made between this magneto terminal and the metal of the engine it would provide a circuit or complete electrical path so that a flow of current would take place around all the electromagnets of the magneto, then through the terminal and the metallic path to the metal of the engine. The current would then pass through the engine to the point at which the electromagnet winding is attached to the engine. In the complete ignition system it is necessary to lead this current through a different path so that an ignition spark may be produced in the cylinders.

*The Ignition Coil.*—In order to secure a current of high voltage, called a high-tension current, when we

have one of low voltage to start with, the low voltage is led through a device called an induction coil or a transformer coil. Such a coil consists of a center made of soft iron and around this center is wound a quantity of comparatively large insulated wire. It is through this winding, called the primary winding,

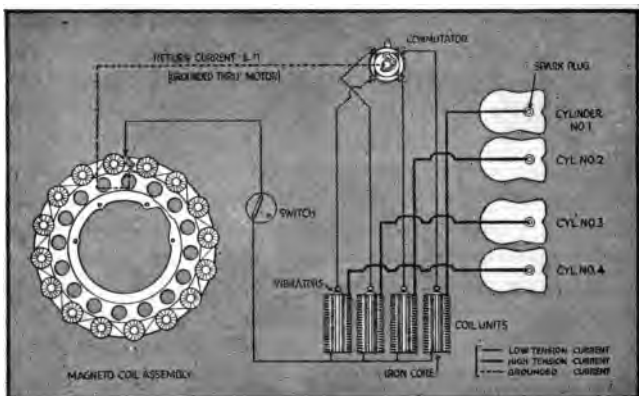

Figure 14.—Path of the Ignition Current.

that the magneto current is allowed to flow. The complete ignition circuit may be traced in Figure 14.

Around the outside of the primary winding is a second coil composed of many thousands of turns of exceedingly fine wire. When a current of electricity flows through the primary winding and then stops flowing or when a current flows in one direction and then changes to another direction the soft iron core of the coil becomes a magnet. Any change in the strength of the core of a magnet induces a flow of current in the fine wire winding which is called the secondary winding. The current induced in the sec-

ondary winding is as many times stronger than that flowing in the primary as the number of turns of wire in the secondary is greater than the number of turns in the primary. In the case of a coil, such as used for motor car ignition, the change in voltage is very great, so that the current taken from the secondary

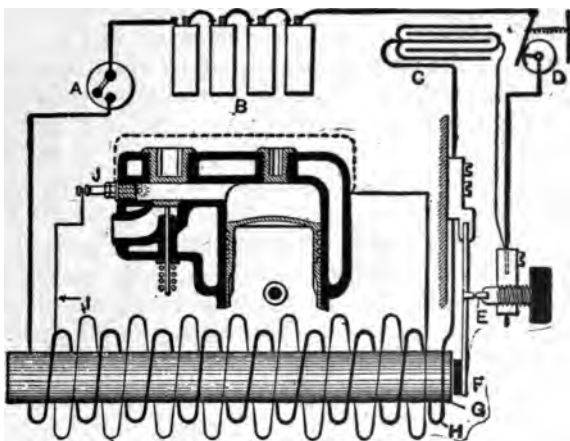

Figure 15.—Vibrator and Coil: A, Switch; B, Dry Cells; C, Condenser; D, Timer; E, Contacts; F, Armature; G, Core of Coil; H, Primary Windings; I, High Tension Winding; J, Spark Plug.

winding has sufficient pressure or voltage to jump across the gap at the spark plug.

*Vibrator.*—The construction of a transformer coil is shown in Figure 15. It will be recalled that current is induced in the secondary winding only upon a change of the magnetism of the core. It is for the purpose of producing the change of magnetism that the vibrator is employed, and the change in this case means that the core is first strongly magnetized by an

unrestricted flow of magneto current around the primary winding and this magnetism is then destroyed by a temporary stoppage of the current flow. By referring to Figure 15 it will be noted that the vibrator hammer is directly above the end of the core. It will be readily realized that whenever the core becomes a magnet it will attract the hammer and whenever this magnetism is destroyed then the hammer will be drawn away from the core by the spring to which the hammer is fastened. In order for current from the magneto to pass through the primary winding of the coil it must also pass from one to the other of the two contact points which are so mounted that they touch each other when the hammer is away from the core and so that the points are drawn apart whenever the hammer is drawn to the core.

A flow of current passing from the magneto through the points and around the primary winding magnetizes the core. The magnetic attraction draws the hammer to the core and separates the points, thus interrupting the flow of current. With no current passing around the core the iron is no longer a magnet. The spring then draws the hammer back and the points again come together, thus re-establishing the flow of current and once more making the core a magnet. This series of events continues at a very rapid rate, with the result that the core of the coil alternately becomes a magnet and then an ordinary unmagnetized piece of iron. These changes of magnetism act on the secondary winding to produce a momentary flow of current each time the core becomes a magnet and also each time it loses its magnetism. Each of these impulses gives a secondary current of strength sufficient to pass between the points of the spark plug and each time the

hammer moves, either separating the points or bringing them together, a spark is caused to jump at the plug.

*The Commutator.*—From the explanation of the action of a four-cylinder engine it will be plain that sparks must occur at the upper end of the compression stroke in order to ignite the gas and start the power stroke. It would not do for the time at which this spark passes to vary because any variation would result in the spark passing either before the compression was completed or after the next down stroke had started. It is to time properly the occurrence of the spark that a commutator or timer is used.

The commutator, as shown in Figure 16, consists of a metallic roller attached to the forward end of the camshaft so that it turns as the camshaft turns. This roller is carried inside of a circular housing composed of insulating material into which are set four metallic contacts. The roller touches these contacts as it turns inside of the insulating ring.

To each of the four contacts is attached a terminal or binding screw which appears on the outside of the commutator case and from each terminal a wire leads to one of the four coils on the dash.

It will be recalled that the camshaft makes one revolution for each two revolutions of the crankshaft and that for each complete cycle in any one cylinder the camshaft turns once. Bearing in mind that the commutator roller is fast to the end of the camshaft and taking any one of the commutator contacts as an example, it will be seen that the roller will touch this contact once for each complete cycle in one cylinder. For each power stroke required in any one cylinder we would have a completed connection through the



unrestricted flow of magneto current around the primary winding and this magnetism is then destroyed by a temporary stoppage of the current flow. By referring to Figure 15 it will be noted that the vibrator hammer is directly above the end of the core. It will be readily realized that whenever the core becomes a magnet it will attract the hammer and whenever this magnetism is destroyed then the hammer will be drawn away from the core by the spring to which the hammer is fastened. In order for current from the magneto to pass through the primary winding of the coil it must also pass from one to the other of the two contact points which are so mounted that they touch each other when the hammer is away from the core and so that the points are drawn apart whenever the hammer is drawn to the core.

A flow of current passing from the magneto through the points and around the primary winding magnetizes the core. The magnetic attraction draws the hammer to the core and separates the points, thus interrupting the flow of current. With no current passing around the core the iron is no longer a magnet. The spring then draws the hammer back and the points again come together, thus re-establishing the flow of current and once more making the core a magnet. This series of events continues at a very rapid rate, with the result that the core of the coil alternately becomes a magnet and then an ordinary unmagnetized piece of iron. These changes of magnetism act on the secondary winding to produce a momentary flow of current each time the core becomes a magnet and also each time it loses its magnetism. Each of these impulses gives a secondary current of strength sufficient to pass between the points of the spark plug and each time the

... the ... of the ...

... the ... of the ...

... the ... of the ...

... the ... of the ...

... the ... of the ...

commutator to the coil and this would produce a series of sparks suitable for igniting the gas.

As already stated, each of the four coils is connected with one of the commutator terminals and from each

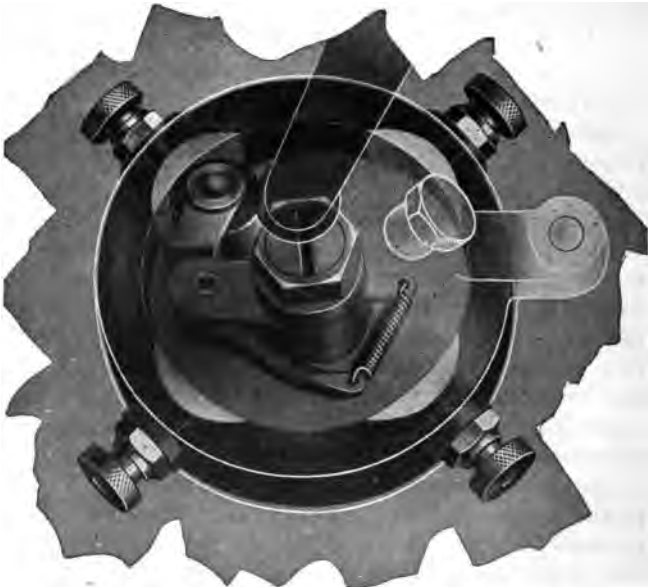

Figure 16.—The Ignition Commutator.

of the coils heavy wire leads to the spark plug in one of the cylinders. This spark plug wire connects with the secondary winding of the coil.

As the roller in the commutator travels around the inside of the insulating ring it makes contact first with one of the segments then with the next one and so on for all four, so that with the commutator in use to

carry electric current a flow will be sent to the four coils, one after the other, and as each coil receives current a secondary impulse will be sent to the spark plug attached to that coil and placed in one of the four cylinders. Four sparks will be produced for each complete revolution of the commutator roller which requires two revolutions of the crankshaft. During the two revolutions of the crankshaft each of the four cylinders must fire once, and this calls for four sparks, one in each cylinder.

The roller in the commutator is placed in such a position on the camshaft that it makes connection with one of the contacts each time that a cylinder is ready to fire and the contact with which connection is made is the one from which a wire leads to the coil used with the spark plug in the cylinder that is then to fire. The next contact in the commutator with which connection is made must be connected with the coil that fires the next cylinder to deliver power, and so on for all four cylinders.

The four coil wires are attached to the commutator terminals in such an order that the cylinders will receive high tension current through the spark plugs in the same order as the firing order of the engine; that is, the first cylinder, then the second, then the fourth and then the third.

*Spark Advance and Retard.*—Even though the burning of the gasoline and air mixture may be like an explosion it is far from instantaneous and an appreciable length of time is required for the flame to travel from the spark at the plug to the parts of the combustion space farthest removed from the plug. This interval of time required for flame travel remains unchanged regardless of the engine speed; in

other words, it requires just as long to completely ignite the charge with the engine running slowly as with it running fast.

It is desirable in the operation of an engine that a spark shall pass at such a time in the compression stroke as will insure that the mixture be completely ignited by the time the piston has reached the upper end of the stroke. Inasmuch as it takes a certain length of time for complete ignition to occur it will be seen that the spark must pass at the plug some little time before the piston reaches the top of the stroke because if the spark did not occur until the end of the stroke then complete ignition would not take place until the piston has started down.

As the engine runs faster and faster it will be necessary to cause the spark to pass earlier and earlier in the compression stroke, because, while the time for ignition remains the same, the piston takes less time to reach the top of its stroke in direct ratio to the increase of engine speed.

In order to provide means for causing the spark to occur at a time during the compression stroke which shall be suited to the speed of the engine, the insulating shell of the commutator, with its four contacts, is so constructed that it may be turned from one position to another by means of a lever located underneath the steering wheel. As the engine speed increases, the lever is moved so that the contacts in the commutator are brought into such a position that the roller will reach them before the piston reaches the top of its stroke, thus bringing the spark earlier or later according to the position of the commutator shell.

A second advantage provided by building the timer so that its position may be varied is that starting the

engine is rendered safer. Should the operator be cranking the engine with the commutator in such a position that the spark would occur before the piston reached the upper end of the compression stroke the ignition and rapid burning of the gas would drive the piston in the reverse direction and cause the starting crank to be thrown in a direction opposite to that in which the operator was turning it. Such an occurrence might easily result in bodily injury to the person doing the cranking, and it may be avoided through moving the timer by means of the control lever into such a position that the spark does not take place until after the piston has started down on the compression stroke. The power of the burning gas then causes the engine to run in the proper direction and take up its cycle.

*Spark Plugs.*—A spark plug consists of a hollow steel shell threaded on the outside so that it may be screwed into the combustion space through the wall of the cylinder. Inside of this shell is an insulating core usually made from porcelain, mica or stone and through the center of this insulating core is a wire having a terminal at its upper end and a point at the lower end. The point at the lower end of the plug is brought within about  $\frac{1}{32}$  inch of the spark plug shell or else a second wire is attached to the shell so that its end is about  $\frac{1}{32}$  of an inch from the end of the first wire. The insulating core is securely fastened into the shell so that when the shell is screwed into the cylinder the whole arrangement is gas tight.

*Current Paths.*—All of the external wiring is shown in Figure 17. Starting from the terminal of the magneto the primary current passes to the switch located on the coil box and from this switch to the primary

winding of each of the four coils. Wires lead from the other ends of the primary windings in the coil to the four terminals on the commutator. Up to this point the current has an uninterrupted flow and might pass

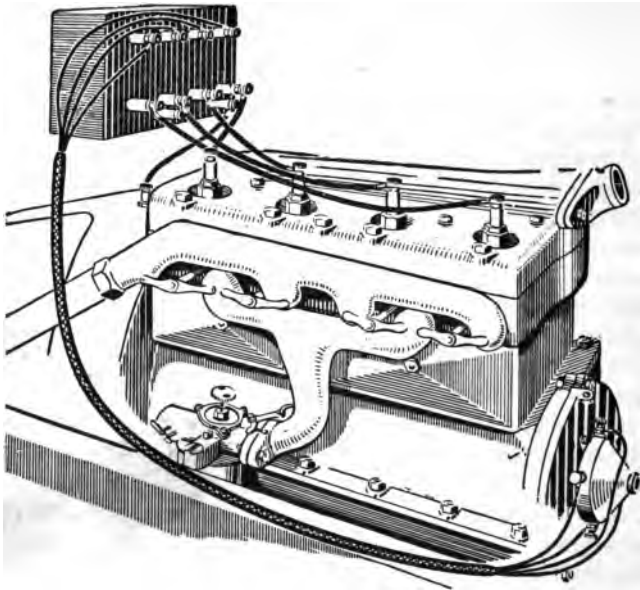

Figure 17.—Ignition Wiring of Older Models.

through all the coils at once except for the fact that the commutator roller can only be in contact with one of the segments at any one time allowing the current to flow only through the corresponding coil. Current flows from the timer contacts through the roller and by means of the roller enters the metal of the engine. Traveling through the engine the current reaches the

magneto again at the point through which the magneto electromagnet winding is attached to the metal. The coil through which the current flows will cause a spark to be produced at the plug in the cylinder to which this coil is attached.

The secondary current induced in the coil through which primary current is flowing passes through the wire leading to the spark plug. This wire is attached to the upper end of the wire passing through the center of the core of the plug and the current takes this path. Its high pressure jumps across the  $\frac{1}{8}$ -inch gap and enters the metal of the engine through the spark plug shell. The balance of the secondary circuit is completed through the metal of the engine and through that part of the primary wiring which leads from the engine to the coils. The two circuits, high and low tension, are thus combined through a part of their length. This makes it necessary to fasten one end of the secondary winding to one end of the primary windings in the coil. However, no difficulties are introduced inasmuch as it is entirely possible to send two distinct currents through the same conductor, provided the paths of the two currents are made separate through some part of their length.

*Battery System.*—The standard ignition equipment on the Ford car includes only the magneto as a source of current, but provision has been made for the addition of dry cell batteries or a storage battery, should the owner so desire.

One of the coil terminals which may be seen on the engine side of the dash leads to the switch on the coil box, and should a set of batteries or a single storage battery be attached to this terminal, the current would flow from the battery through the switch and there-



after take the same path as would the magneto current. The switch handle has two positions and when on the side marked MAG the current will flow from the magneto to the ignition circuits, and with the switch handle toward the side marked BAT the current will be taken from the battery and sent to the circuits. Should a

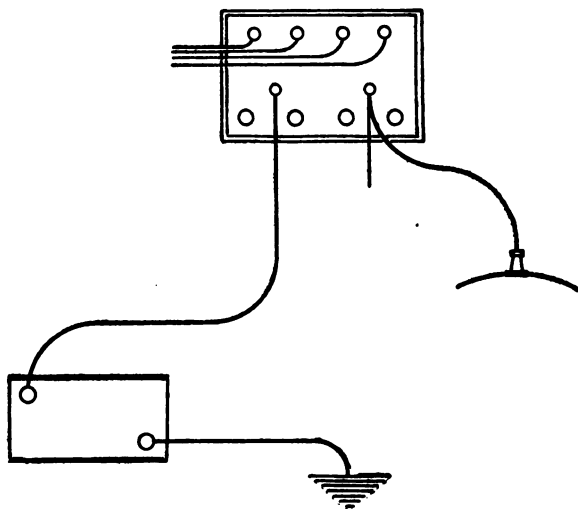

Figure 18.—Using a Battery With the Ford Ignition System.

battery be used, one of its terminals is connected with the above mentioned terminal, while the other side of the battery is attached to the metal of the engine or of the car so that the circuit may be completed just as would be the case with the magneto in use. The method of connecting either a storage battery or one or more sets of dry cells in the Ford ignition system is shown in Figure 18.

## THE FORD OILING SYSTEM

The Ford oiling system is so designed that upon introduction of oil into the engine an adequate supply of lubricant is delivered to all of the engine bearings, to the timing gears, to the cylinder walls, to the transmission and to the clutch.

The view of the engine shown in the Frontispiece will make the operation of the oiling system clear. Oil is poured in through the breather pipe which is an opening near the front of the engine and on the right hand side. The oil flows down into the pan underneath the crankshaft and runs back until it rises to a considerable depth in the depression of this pan underneath the flywheel.

On the right hand side of the lower part of the flywheel housing are two pet-cocks which may be seen by looking underneath the car. The oil level should be maintained somewhere between the pet-cocks. A supply of medium light engine oil should be poured into the breather until it runs out of the upper one of these cocks. The cock should be opened and allowed to remain so until the oil stops flowing. Under no circumstances should the oil level be allowed to run so low that the lubricant will not flow out of the lower pet-cock when it is opened.

The flywheel dips into the reservoir of oil while the engine is in operation and a considerable quantity of the oil is carried around with the flywheel and discharged into a small funnel carried in the side of the flywheel housing at the right and about two-thirds of the way toward the top. The oil that discharges into this funnel passes through a pipe to the forward end of the engine where it flows onto the timing gear

after lubricating the gears drops down into the engine pan. This pan has a slight slope from front to back and under each connecting rod is a depression which fills with oil. During each revolution of the crankshaft the lower end of the connecting rod dips into the oil in the depression and the oil is splashed so that it forms a mist or vapor which lubricates the cylinders and pistons.

Part of this oil mist is caught in small troughs located above each of the bearings which support the crankshaft and above each bearing which supports the camshaft. The oil passes from these troughs through the bearings and lubricates their surfaces.

The splash from the flywheel fills the transmission and clutch case with sufficient quantity of oil to keep the gears and clutch parts well lubricated.

#### THE FORD COOLING SYSTEM

The heat of the burning gas in the cylinders of the engine reaches a point between 2,500 and 3,000 degrees Fahrenheit. Lubricating oil will not stand a temperature much in excess of five to six hundred degrees and it is therefore necessary to provide means for preventing the temperature of the cylinder walls from rising too high. In order to carry away the excessive heat generated by the burning gas the upper part of the cylinders is surrounded by water. The part of the engine casting which is made to retain the water is called the jacket. The cooling system is shown in Figure 19.

Water is kept in circulation around the cylinder jackets and is then carried to a radiator at the front of the car by means of which the heat which the water has absorbed from the cylinder walls is dissipated into

the air. The radiator consists of two parts or tanks, one at the top and one at the bottom, each holding a quantity of water. Between the two tanks is a num-

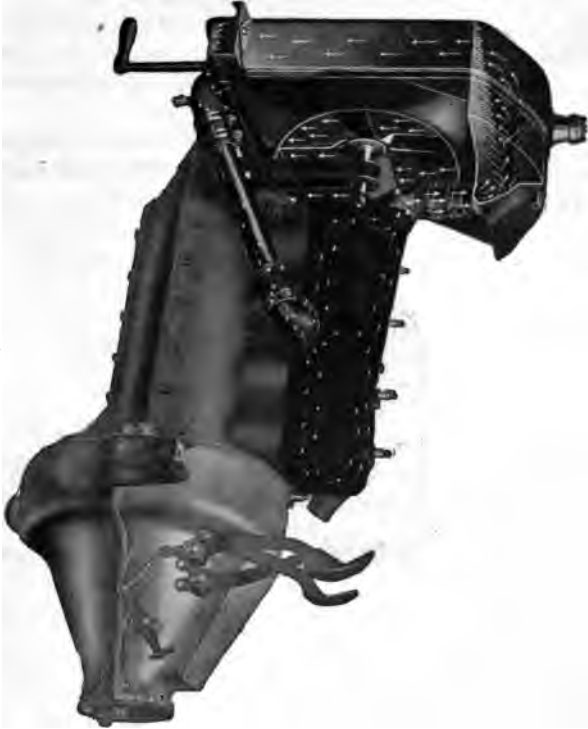

Figure 19.—The Ford Cooling System.

ber of copper tubes. Crosswise of the radiator and surrounding the tubes are fins of thin sheet metal. •

Hot water from the engine enters the radiator at the top and in passing down through the tubes loses its heat through the fins and the surface of the tubes

until when it reaches the lower tank it is comparatively cool and ready to be returned to the engine water jackets.

A large volume of air is drawn through the radiator, Figure 20, by means of a four-bladed fan located just behind the radiator and driven by means of a flat leather belt from the forward end of the crankshaft. An even flow of air is drawn through all parts of the radiator because of the fact that the fan and the rear side of the radiator are enclosed by a sheet metal hood in the form of a funnel.



Figure 20.—The Radiator.

The water is caused to pass through the circulating system between the engine and radiator by thermosyphon action, which means by the heat of the water itself. It is a well known fact that warm water will rise through cool water. This may be demonstrated by placing a pan of cool water over a burner and then throwing in some light material such as sawdust, when it will be seen that a constant stream of water is pass-

ing up and above the fire and down around the cooler edges of the vessel.

This principle is made use of in the Ford cooling system. The cylinder jackets, the radiator and their connecting piping are all filled with water and as soon as the engine has run for a few moments the water in the jackets becomes much hotter than the water in the radiator. This heated water rises and passes through the upper hose connection to the top of the radiator. As soon as the water reaches the radiator it commences to cool because of the air. Becoming cool it falls and passes to the bottom tank of the radiator. The hot water leaving the cylinder jackets causes a continual flow to the engine from the lower part of the radiator so that the circulation is maintained as long as the cylinder walls are hot.

## CHAPTER II

### THE FORD TRANSMISSION SYSTEM

The transmission system includes all of the parts that do active duty in carrying the engine power to the rear wheels. In the case of the Ford car the unit that first receives the power of the engine is the combined clutch and change speed gearing. This device either allows the engine to be entirely disconnected from the rear wheels and their driving shafts, thus allowing the engine to run while the car stands still, or else allows the engine to be connected with the rear wheels to drive them forward at a greater or less rate of speed. The transmission also serves to drive the wheels in a reverse direction while the engine itself still runs forward.

The gasoline engine requires the use of such a device for two reasons. One reason is that this type of engine is not in itself reversible and when it is desired to reverse the direction of motion of the car it must be done by means of a change secured through gearing of some form. The second is found in the inability of such an engine to operate efficiently above or below certain limits of speed. It is not economical to operate a gasoline engine at less than three to four hundred revolutions per minute and for mechanical and carburetion reasons it is not usually advisable to attempt speeds above two thousand revolutions per minute.

If the engine were attached to the driving wheels with a fixed and unchanging ratio of gearing, engine speeds from 400 to 2,000 revolutions per minute would

correspond to car speeds between four and twenty miles an hour. This is obviously too limited a range for all classes of work.

An engine capable of delivering twenty horsepower at one thousand revolutions per minute would only



Figure 21.—The Transmission and High Speed Clutch.

give about half that power at one-half the speed and one-fifth the power at one-fifth the speed. It would, therefore, be impossible to start a car from a standstill or to secure good pulling at very low speeds unless some means were provided for allowing the engine to run fast enough to develop the necessary power with the car moving very slowly.



The Ford transmission, shown in Figure 21, is of the planetary type by which is meant a type in which all of the gears remain in mesh with each other at all times. This type is distinguished from the sliding gear type in which different pairs of gears slide together so that their teeth engage, the pairs being selected according to the road speed wanted or according to whether it is desired to go forward or backward.

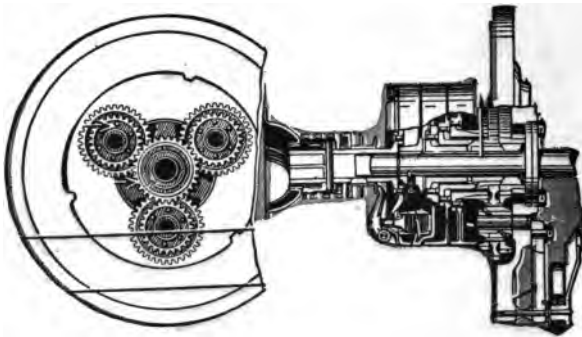

Figure 22.—Planetary Gears in Transmission.

The gears in the Ford transmission are arranged in sets as shown in Figure 22 and all of these sets revolve around one main shaft. The different sets are brought into action by stopping the movement of the parts which support one or more of the gears. The gears which are to be stopped are carried on parts to which are attached cylindrical metal drums. Bands, similar to brake bands, are placed around these drums and provided with attachments by means of which any desired band may be tightened to stop the revolution of its drum and to bring the necessary sets of gears into play.

Mounted with their centers in line with the main shaft of the transmission and in line with the crankshaft of the engine are three gears two of which are attached to two separate drums while the third is called the driven gear and is attached to the shaft through which the rear axle may be driven. These three gears vary in size but are all fastened together so that they rotate at the same rate of speed and as a unit. In mesh with these gears and spaced equidistant around their circumferences are three sets of three gears each.

When it is desired to start the car from a standstill, a pedal is pressed which causes one of the drums to stop revolving. This drum is attached to one of the gears of the three on the main shaft. The pins or axles of the three sets of three gears are fastened to the flywheel of the engine so that when the engine is running the sets of gears are carried around on the outer edges of the gears mounted concentric with the shaft. Because of the fact that the one gear being held by the band and drum is standing still, the sets of three gears must turn around their own centers in traveling around the outside of this center gear, and, depending on the relative sizes of the stationary gear and the gears traveling around it, a motion is imparted to the driven gear on the shaft which may be either forward or backward; that is, in the same direction as that in which the engine is turning or in the opposite direction. In either case the motion imparted to the driving shaft is much slower than that of the engine crankshaft.

If the pedal which is pressed is the one which causes the middle gear of those on the main shaft to remain stationary, the car moves slowly ahead, while if the

reverse pedal is pressed another band is tightened which causes the rearmost gear and the drum attached to this gear to remain stationary, causing the car to move slowly backward.

*The Clutch.*—After the car has gained some momentum with either the low or reverse gear in operation it is desirable to run faster without greatly increasing the engine speed, this result is accomplished by means of the high speed clutch.

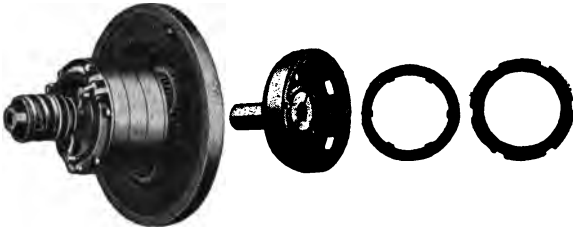

Figure 23.—Transmission With Clutch Drum and Discs.

This clutch is carried immediately back of the change speed gearing, as shown in Figure 23, and is composed of a number of discs, part of this number being attached to the engine crankshaft while the other part is attached to the driving shaft which carries power to the rear wheels. In assembling the clutch the discs attached to the engine and those attached to the driving wheels are alternated; first a driving disc attached to the engine, then a driven disc attached to the shaft. The discs are normally held tightly pressed together so that when some of them revolve with the engine the others must also revolve and power is thus carried through the clutch. The discs are pressed together by a powerful coiled spring and it is possible by pressure of the driver's foot on the same pedal

that operates low speed to remove the tension of this spring from the clutch discs so that those attached to the engine may rotate freely without driving those attached to the shaft. With the pressure thus removed from the clutch, the engine may run without driving the car, but when the spring pressure is allowed to act, the driving shaft leading to the rear axle is caused to rotate at the same speed at which the engine crankshaft is rotating and the car is driven at a corresponding speed.

The slow speed forward is usually called low speed, the slow speed backward is called reverse, while the speed obtained with the clutch engaged is called high speed or direct drive. When the spring pressure forces the clutch discs together, the clutch is said to be engaged, and when the spring pressure is removed, the clutch is said to be released.

It will be noted that in any of the speeds, low, reverse or high, that the car speed may be gradually brought up to a point corresponding with the engine speed. The foot pedals which act to tighten the bands on the drums are applied by a gradually increasing pressure of the driver's foot so that the gears acted upon are not immediately brought to a stop but are caused to run slower and slower until the car speed has reached a point at which a complete engagement of the drum and gears may be effected. In a like manner the high speed clutch is allowed to gradually engage by slowly operating the pedal which lets the spring pressure act on the discs so that the driven discs slip between the drivers until the car speed has reached a point suitable for complete engagement. The clutch discs are not damaged by such operation, provided the slippage does not continue for too long a

time, because the entire mechanism operates in a bath of oil and because the discs are made from hardened steel. The bands are lined with an asbestos fabric composition well suited to withstand wear and friction, and when this lining has finally been worn thin,

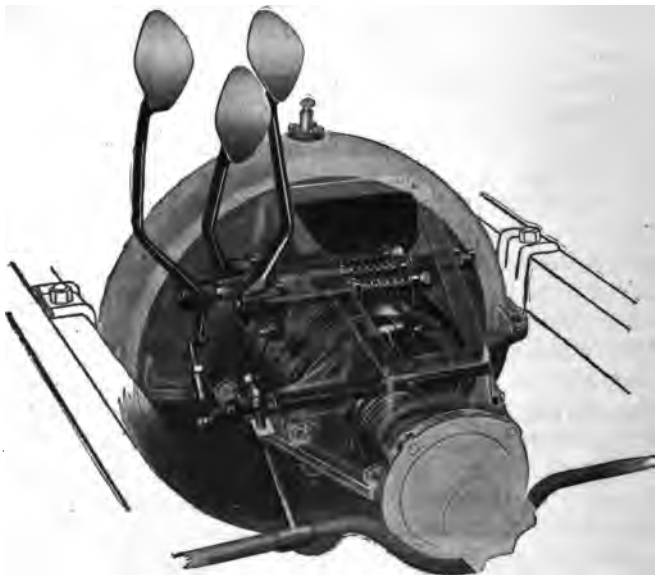

Figure 24.—Control Pedals of the Transmission.

it may be renewed or the whole band may be renewed at slight expense.

The change speed gearing and clutch are controlled by the driver through foot pedals, as shown in Figure 24, and by a hand lever attached to a cross shaft. The left hand pedal, when pressed forward, causes the low speed band to tighten, and when allowed to come all

the way back, allows the clutch spring to press the discs together. The center pedal, when pressed forward, tightens the reverse band. The right hand pedal is used for applying one of the brakes. The hand lever is used for applying the rear wheel brakes. When pulled about half way back and held there by its ratchet it prevents the clutch spring from pressing the sets of discs together.

The use or misuse of the transmission gearing has a great deal to do with the smooth operation of the car or with the lack of smoothness. With the car standing still and the clutch and gearing disengaged it is not necessary for the engine to develop any considerable power, but just as soon as the car is started a load is imposed on the engine and it is immediately necessary to generate more power.

For this reason the driver's fingers should be on the throttle lever when the low speed pedal is first pressed forward. As soon as the engine slows down, due to the load, the throttle lever should be moved down a notch or two while the foot pressure is gradually increased on the pedal. The amount of pedal pressure and the amount of throttle opening should keep pace with each other so that the engine delivers more and more power as required but still does not reach an excessive speed and of course does not come to a stop.

When the pedal is pressed with sufficient force to prevent any further slippage between the engine crankshaft and the drive shaft, then the throttle should be opened until the car attains a speed of about six or eight miles an hour. It will be realized that the low speed gearing must now be released for a short interval of time while the pedal is coming back into the high speed position, and if a throttle opening suf-

ficient to allow the engine to drive the car is maintained during this interval, then the engine will race at a great speed, doing possible damage and making a very objectionable noise.

To avoid this condition it will be necessary for the driver to momentarily close the throttle. This closing should not take place until after the foot pressure has been removed from the pedal because if the throttle were to be closed with the pedal down the engine would immediately reduce its speed and the car speed would likewise be reduced.

This reduction of car speed is one thing that should be avoided. Another reason for this momentary closing of the throttle is to allow the engine speed to drop to a point that will correspond to the desired rate of revolutions after the high speed clutch has been engaged. This rate will of course be much less than with low speed in use. When the pedal is released and the throttle has been partially closed the engine will slow down and at this instant the pedal should be allowed to come all the way back, which will engage high speed. If the operations are carried out according to the above suggestions the change from one speed to another will be accomplished without its being noticeable to the occupants of the car and with the pedal all the way back the speed of the car may thereafter be controlled by moving the spark and throttle levers until such time as it is desired to release the clutch for one reason or another.

#### DRIVING SYSTEM

*The Universal Joint.*—With the car traveling over rough roads the spring action allows the body and frame to move up and down in relation to the wheels.

and axles. The engine is mounted on the frame and must therefore move with the frame and body, but power from the engine is carried to the rear axle and wheels which do not move with the frame. It is therefore necessary to provide some form of connection between the engine and rear axle which will transmit power while the springs are in action.

At the rear end of the transmission is a joint, called a universal, which connects the transmission shaft with the propellor shaft which runs to the rear axle and this joint carries rotary motion from one of these shafts to the other while the shafts operate at an angle which changes with every movement of the springs.

This universal joint is composed of two T-shaped pieces, one of which fastens to the rear end of the transmission shaft and the other one of which fastens to the front end of the propellor shaft. The piece which fastens to the transmission is squared and fits into a square hole on the end of the transmission shaft while the piece for the propellor shaft is made with a square hole which fits over the squared forward end of the propellor shaft.

In assembling the universal the two T's are placed with their heads crosswise to each other and while in this position they are fastened together by a metal ring which provides a bearing for the ends of the T's. This arrangement effects a double hinge which may be bent up and down or crosswise, or in any combination of these motions at the same time. The parts and their appearance when assembled are shown in Figure 25.

The universal is enclosed in a hollow steel shell of spherical shape and this shell is bolted to the rear of the transmission housing by means of a flange. The



shell is fastened to the forward end of the housing or tube that encloses the propellor shaft and the driving force from the rear axle is transmitted through the propellor shaft housing to this spherical shell, then through the transmission, the engine case and the under pan to the side members of the frame.

The spherical housing is free to move inside of the flange that holds it to the rear end of the transmission and these parts form a ball and socket joint which allows the rear axle to move up and down and

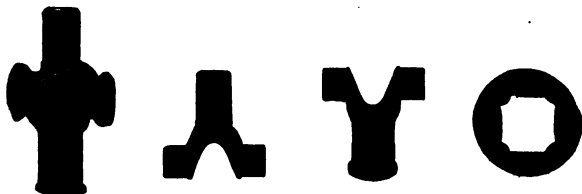

Figure 25.—Universal Joint; Completely Assembled, also Showing Parts.

also allows one end of the rear axle to be higher than the other end while the driving effort is carried through the ball joint without any tendency to twist the engine, the transmission or the power plant.

*The Triangular Drive.*—In order that the car may respond to the action of the steering wheels and that it may run straight ahead when desired, it is necessary that the outer ends of the rear axle and the rear wheels themselves be maintained at the same distance back of the car at all times and also in line across the length of the car. This distance is maintained by two long rods, one attached to each end of the rear axle and both running forward and toward the center of the car until they attach to the forward end of the propellor shaft housing just back of the universal

joint and ball housing. An examination of Figure 26 will show that the rear axle and driving shaft form a unit which attaches to the main body of the chassis through the universal and the flexible ball joint surrounding the universal. This construction provides



Figure 26.—The Rear Axle and Drive Shaft Assembly.

a form of drive in which the rear axle may assume practically any possible position on the road surface without affecting the alignment of the engine or of any other part of the car.

*The Differential.*—When the car turns a corner the wheels on the outside of the curve travel faster than those on the inside because both inside and out-

side wheels must make the turn in the same length of time and the outside path is longer. The front wheels are independently mounted on the ends of the front axle and one is therefore free to travel faster than the

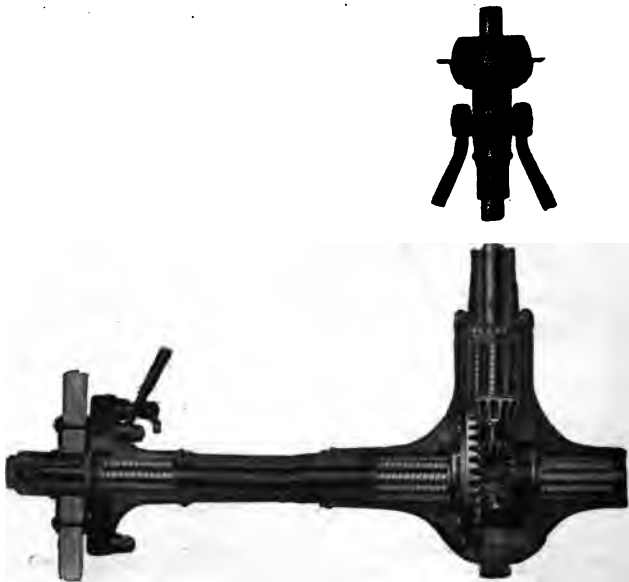

Figure 27.—Working Parts of the Rear Axle.

other. The rear wheels, however, do the driving and cannot be independently mounted.

In order to allow the outside driving wheel to run at the required increase of speed the driving axle is made in two parts. The outer end of one part of the driving axle shaft turns the wheel on one side while the outer end of the other part of the shaft turns the other wheel. The inner ends of the two parts

of the driving shaft are fastened into a set of gears that receive power from the engine through the propeller shaft. This set of gears is so arranged that the driving wheels may travel at different rates of speed while both receive power. The differential gears are carried at the center of the axle together with the bevel gears as shown in Figure 27. Power from the engine is carried through the drive shaft to its small bevel gear and this small gear turns the larger bevel

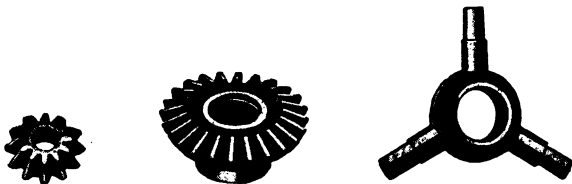

Figure 28.—Differential Spider and Gears.

which in its turn causes the set of differential gears to revolve as a unit.

The principal parts of the differential are shown in Figure 28. The three small differential gears or pinions are mounted on the three prongs of the spider. With these small gears in place on the spider the two larger gears, which are fastened to the inner ends of the axle shafts, are meshed with the three small gears. The power received by the large driving bevel gear is transmitted through a metal case in the differential spider and the spider is carried around with the large driving gear. The small differential pinions must of course travel with the spider and in traveling they cause the axle shafts and their gears to revolve.

It will be seen that should one rear wheel with its axle shaft stand still, the other wheel could still be

revolved and in this case the small differential pinions would roll round and round on the gear fastened to the stationary axle shaft and in rolling would allow the other axle shaft to turn. This is the action that takes place in turning a corner, although neither wheel comes to a full stop, but simply travels slower or faster than the other wheel.

It is possible that the action of the differential may be more clearly understood by considering the following illustration. If two loose wheels were to be mounted at opposite ends of an axle and a rod passes through between the spokes of one wheel and across through the spokes of the other, by pushing at the center of this rod both wheels would be revolved provided they both met with equal resistance to rotation. Should one wheel be against an obstruction that prevented its moving ahead then the end of the rod through the spokes of this stationary wheel would remain stationary and all the effort applied at the center of the rod would exert its force against the other wheel causing this other wheel to move ahead.

If the first mentioned wheel should stand still and allow the other to move ahead any considerable distance then the rod would pass out from between the spokes, but should the rod be replaced with a wheel without a rim, or with a series of spokes arranged around a common center, then it will be seen that another one of these spokes would engage with the wheel that moved ahead and the power would continue to be applied to both wheels.

In the differential the two wheels mounted loosely at the ends of the axle are replaced by the two bevel gears at the inner end of the wheel shafts and the single rod or the assembly of spokes around a com-

mon center are replaced by the small bevel gears which are mounted on the differential spider. The rotation of this spider by means of the large driving bevel gear to which it is fastened keeps the small bevel gears traveling around, and if either one of the road wheels remains stationary or goes slower than the other, then the small bevels in the differential roll around on the axle shaft gear and still transmit power to both axle shaft gears at all times. As long as the car is turning a corner it will be necessary for one road wheel to travel faster than the other and the small bevels will continue to roll over the driving shaft gears in this manner, but whenever the car travels straight ahead there will be no relative motion between any of the gears composing the differential.

*The Rear Axle.*—The rear axle of the Ford car consists of two mechanical units. One unit is composed of the driving shafts, their bearings and the gearing contained in the axle. The other unit is the outside or housing of the axle which serves to carry and protect the working parts and at the same time carries the load of the car body.

The Ford axle is of the type known as semi-floating. A semi-floating rear axle is one in which the axle shafts are each carried by two bearings, one at the inner end and the other at the outer end of each shaft. The driving bevel gears together with the differential are supported by the inner ends of the axle shafts, while the outer ends of these same shafts carry the wheels. The relation of each part to the other is shown in Figure 27. It will be seen that the long axle shafts are supported at each end and that at the outer end they terminate in a taper which fits into a taper hold in the wheel hub.

The weight of the car body is supported by the springs and the springs rest in brackets on the outside of the axle housing. Passing through the axle housing the weight is supported by the bearing toward the wheel and through this bearing by the axle shaft. The axle shaft is of course supported by the wheel.

The semi-floating type of axle possesses the advantage of simplicity and light weight and at the same time is the cheapest construction to manufacture. It will be realized that a simple and light design may be better built for a given amount of material and expenditure than could a heavy or complicated type of axle. The most noticeable difference between the semi-floating axle and axles of three-quarter floating or full floating type is that in the semi-floating axle the wheels are carried by the outer ends of the driving shafts, while with the other types the wheels are carried on the outside of the axle housing so that the drive shaft is left free to carry the power and does not support any appreciable weight.

The semi-floating type of axle requires but four bearings on the axle shafts, while the full floating type requires six. In the semi-floating axle the bearings on each half of the axle shaft are separated by nearly half the distance across the axle, and this distance between the bearings serves to give the wheel a more rigid support than would be the case with the bearings placed close together. This is true for the same reason that a bar may be more rigidly supported when grasped at two points far apart than when held with the hands close together.

The bearings used in the Ford rear axle are of flexible roller type. Each bearing is composed of a series of rollers, each roller about one-half inch in

diameter and several inches long. Each roller consists of a single strip of steel formed into a hollow spiral. This spiral assists in carrying the lubricant from end to end of the bearings, and at the same time provides an anti-friction mounting of great load-carrying capacity in proportion to its weight and with ability to resist shocks because of the springlike construction.

The rollers composing one of these bearings are carried in a framework called a cage, and, depending on the point at which the bearings are used, they may or may not be enclosed by a cylindrical shell, called a race. In any case the spirals in adjacent rollers run in opposite directions, this construction assisting to distribute the load and also to carry the lubricant back and forth from one end of the bearing to the other.

#### RUNNING GEAR

The parts of the power plant, drive system and control system are carried on a steel framework so that they are held in place and can do their work. The frame is made of such size and shape that all the parts just fit in place on the bars that make up the frame.

In order to protect the machinery against jars and bumps that might damage it and also to make the car ride easy for the passengers, the frame is carried on springs placed between it and the axles.

The front axle of the car, in addition to carrying part of the weight, includes parts of the steering gear so that the front wheels may be turned as the driver wishes.

The rear axle is made up of hollow tubing so that



the driving shafts and differential may be carried inside of the hollow part. This protects the working parts from dirt and also makes the axle stronger.

Automobile wheels are made with either wood or wire spokes, and because of the greater strength required, they are usually much lower than carriage wheels.

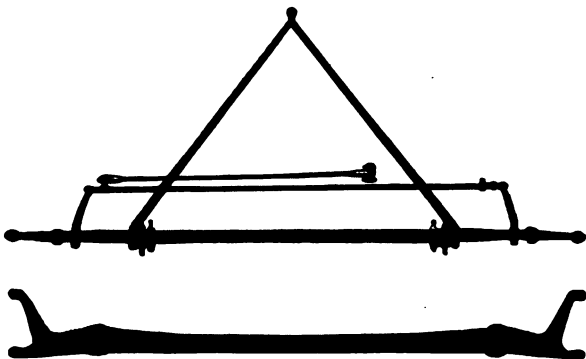

Figure 29.—The Front Axle and Radius Rods.

In order to absorb the small vibrations and jars and leave only the larger bumps for the springs to take care of, rubber tires are placed around the rim of the wheel. These tires are hollow and filled with compressed air.

The frame, springs, axles, wheels and tires make up the running gear of the car.

*Front Axle.*—The appearance of the front and of the top of the Ford front axle is shown in Figure 29. The center section is a steel forging of I-beam section, this shape providing great strength with light weight. The front axle of the automobile, unlike that

of a carriage or wagon, does not turn at its center, but consists of a central portion which remains stationary with reference to the frame. In jaws on the end of this center are pieces called knuckles and spindles. The front wheel hubs are supported on the spindles and the spindles themselves are hinged on large vertical bolts so that they may be turned toward

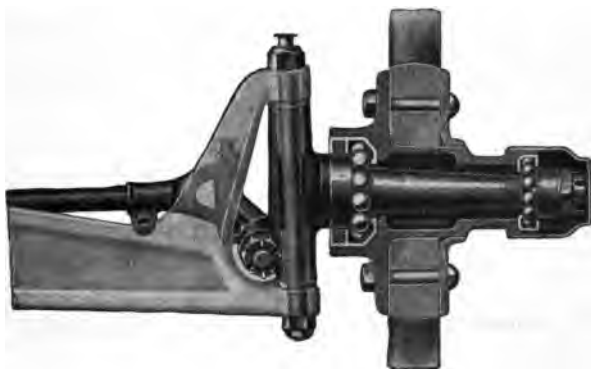

Figure 30.—Front Wheel Spindle and Bearings.

the front or rear, thus allowing the car to turn a corner.

The spindles are provided with arms extending toward the rear of the car and these arms are fastened together with a transverse rod called a tie rod. By moving this tie rod from side to side the spindles and wheels are moved. The construction of the spindle and front hub is shown in Figure 30. The hub is carried on bearings of the cup and cone ball type. One of these bearings is toward the inner end of the spindle and is the larger one of the two, while the other one is at the outer end and serves to maintain

the wheel in an upright position, but does not carry much of the load. A cup and cone bearing consists first of a conical seat fastened to the spindle. The cone of the inner bearing points out and the cone of the outer bearing points in. A cup-shaped portion of these bearings is carried in the wheel hub and serves to retain the steel balls in position as they travel around the cones.

A cup and cone ball bearing is well suited to use in the front wheels of a motor car because of its ability to withstand thrust loads as well as those of a radial nature. A line drawn through any one of the balls from its point of contact with the cup to the point of contact with the cone would be at an angle of almost 45 degrees. Vertical loads caused by the weight of the car, and which are called radial loads, tend to press the cups straight down toward the cone, while thrust loads such as are caused by the car's turning a corner or running at an incline on the road, tend to press the cup sidewise against the cone and along the length of the spindle. Because the points of contact between the balls and the cup and the cone are at an angle to each other it is impossible to press the cup either sideways or up and down and both of these types of loads are therefore resisted with very little friction.

The objection is sometimes raised against a cup and cone bearing that it is of an adjustable type and is therefore subject to misuse at the hands of those who do not understand its construction. It is very essential that a bearing of this type, or of any other adjustable type, be neither too tight nor too loose. Looseness permits play which results in more or less severe shocks and these shocks tend to cause fractures

on the wearing surfaces of the balls and also on the cups and cones. Excessive tightening of the bearing causes unnecessary loads to be imposed on the balls with the result that they quickly cut into the surfaces of the parts between which they roll and the life of the bearing is very much shortened.

In making an adjustment of the cup and cone bearing the wheels should be jacked clear of the ground and should then be started to revolve. If the wheel comes to rest quickly it indicates that the bearing is too tight and it should be loosened. If the wheel spins freely the bearing should be gradually tightened by screwing the cone farther onto the spindle until there is a slight amount of binding, which causes the wheel to come to a stop quicker than it did with the bearing loose. After the bearing has been tightened in this way it should be loosened a fraction of a turn, which will provide a good running adjustment.

The center line of the spindle is inclined so that the top of either front wheel is farther away from the center of the car than is the bottom of the wheel. In other words, the wheel tips out at the top or is cambered. By such a construction the point of the front wheel which is in contact with the road is brought very nearly into line with the axis of the long vertical bolt on which the spindle and knuckle turn. Steering is thus made much easier because it requires less effort to turn the wheel around a point resting on the ground than to move the whole wheel in a part of a small circle, which would be the case if the wheels were straight up and down.

The steering wheels of the car are held in such a position by the tie rod that their front edges are closer together than are the rear edges. This con-

struction is called gathering. This gather is provided to compensate for any slight looseness or deflection that may take place in the joints of the knuckle and of the tie rod. The front wheels are pushed along over the road by the car, and inasmuch as there is a certain resistance to motion caused by the road surface, the tendency of the wheel is to slow up at all times while running. This tendency causes the

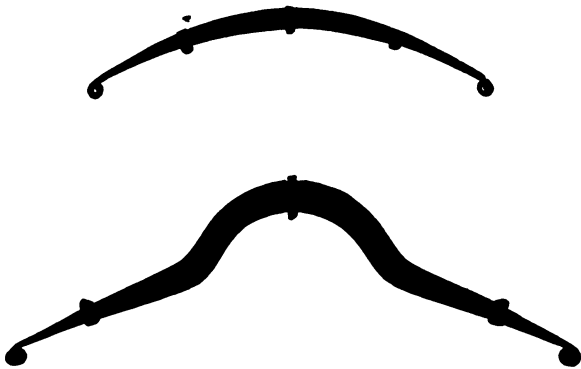

Figure 31.—Front and Rear Springs.

wheels to press back on the outer ends of the spindles. This pressing back takes the slack out of all the front axle and steering parts and at the same time tends to cause the front edges of the wheels to run away from each other and to cause the rear edges to come together. This tendency takes up almost all of the above mentioned gather.

The front axle is maintained in correct relation to the frame by a pair of radius rods which, together with the axle center, form a triangle. The rear point of this triangle is fastened to the lower part of the

engine by means of a ball and socket joint. This connection keeps the front axle in line with the rear axle and at the same time allows the outer end to move up and down as the wheels travel over inequalities in the road.

*Springs.*—The Ford car uses but two springs and these are of the semi-elliptic type as shown in Figure 31. Contrary to ordinary practice, the Ford springs run crosswise of the car rather than lengthwise. The front end of the frame is carried at the center of the front spring and the rear end of the frame is carried at the center of the rear spring. The outer ends of the springs rest on the axles close to the wheels.

Each spring is composed of a number of rather thin leaves and these leaves vary in length from bottom to top of the set. The lower leaf is long enough to extend clear across from support to support, while those above it grow shorter and shorter until the one next to the frame is less than half the length of the lower one.

*Frame.*—The frame of the Ford car with the power plant and rear axle mounting is shown in Figure 32. The frame itself is a rectangular assembly of pressed steel channels. The frame supports the power plant and body and is itself supported on the springs and the front and rear axles.

The Ford principle of three-point suspension is well illustrated by the view in Figure 32. The power plant is supported in front and at its two sides on the frame. The rear axle is supported toward the front by the rear end of the power plant and at its outer ends by the triangular radius rods. The front axle likewise forms a triangular system as already explained.

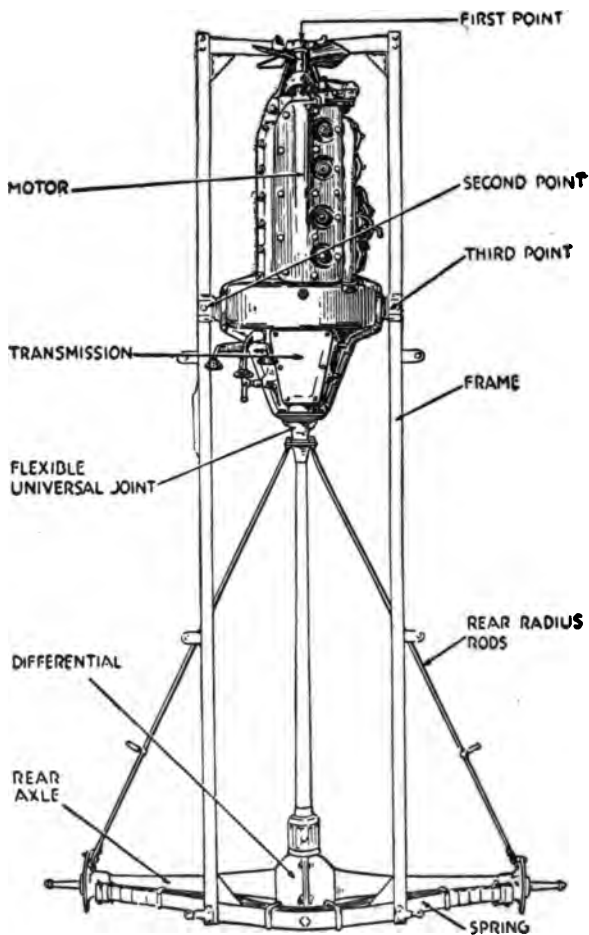

Figure 32.—Power Plant, Transmission System and Frame, Showing Three-Point Suspension.

## CHAPTER III

### DRIVING AND CONTROL

#### THE STEERING GEAR

The steering gear includes the hand wheel which is turned by the driver, and all of the parts that carry the turning effort from this wheel to the front road wheels. The parts of the steering gear which are fastened directly to the front axle have already been mentioned in Chapter II. The principle of this type of steering gear is illustrated in Figures 33 and 34.

The arms which move the wheel spindles extend from the axle and carry the tie rod. This tie rod is moved crosswise by a steering link whose one end attaches to the right hand end of the tie rod and whose other end is attached to a crank or arm at the lower end of the steering column. Movement of this crank pulls the steering link one way or the other and through the tie rod and spindle the front wheels are turned.

In order to make the steering gear operate properly it is designed so that a line drawn through either one of the vertical spindle bolts and then through the end of the tie rod which is back of this bolt would lead to the center of the rear axle.

A steering gear laid out in this way is illustrated in Figure 35. The tie rod is of such length that when one of the front wheels is turned the other turns also, but to either a greater or less degree than the first one.



Regardless of the amount that either wheel is turned, it will be found that lines through their spindles point to one and the same point and that this point lies in a line drawn through the rear axle. The degree of turning, shown in Figure 35, causes the spindle of



Figure 33.—Steering Wheel and Gearing.

the left hand front wheel to point toward *A*, while at the same time the spindle of the right front wheel also points toward *A*. This point *A* is found to lie in a line drawn through the center of the rear axle. With all of the wheels in the position shown they will travel around *A* as a center and the car will follow the curved path shown.

The construction of that part of the steering gear which is directly acted upon by the hand wheel is shown in Figure 34. It consists of a shell on the inside surface of which are gear teeth. This shell is fastened to the upper end of the steering column and, with the housing of the column, remains stationary. In mesh with the teeth in this shell are three small pinions which are mounted on a triangular plate fastened to the upper end of a shaft extending down through the

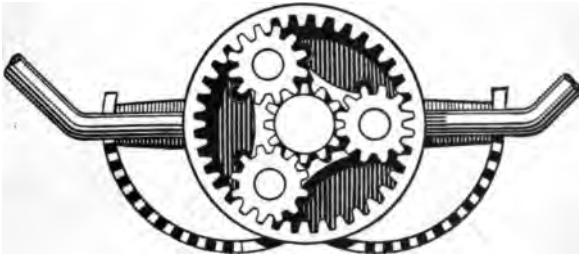

Figure 34.—Principle of the Ford Steering Gear.

center of the steering column. The steering wheel carries another small pinion which is shown at the center of the illustration and which meshes with all three of the pinions which are attached to the steering column shaft.

When the steering wheel is turned by hand it revolves the central pinion and in doing so causes the three steering shaft pinions to roll around the inside of the toothed shell. In traveling around the inside of this shell the three pinions carry with them the triangular piece on which they are mounted and the steering shaft is thus caused to go through part of a revolution.

It will be realized that it would require several

revolutions of the steering wheel and its gear to cause the three pinions to travel all the way around inside

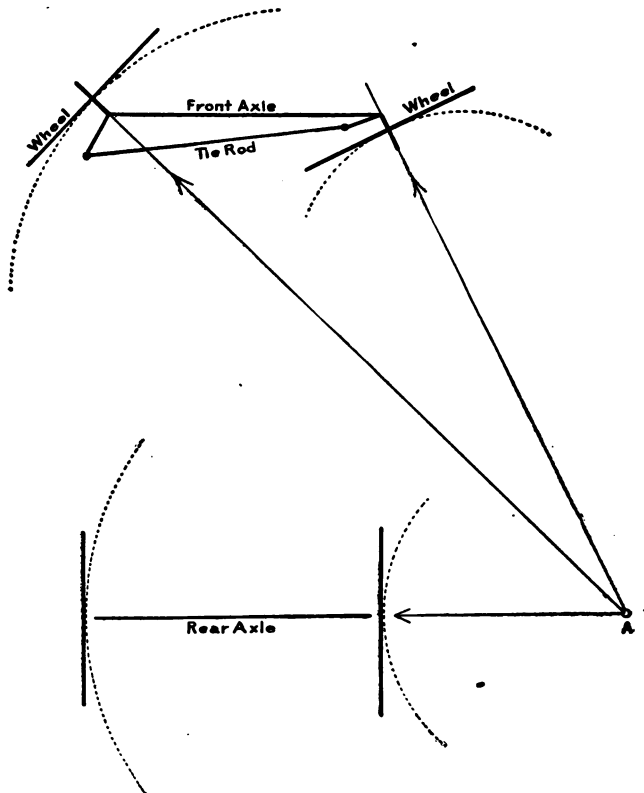

Figure 35.—Operation of Steering Gear in Turning.

of the shell. It therefore requires a considerable part of a revolution or even more than one complete revolution of the steering wheel to effect any great change

in position of the steering shaft. This reduction of motion increases the power applied by the driver to the road wheels and gives good control of the direction in which the car shall travel.

The rod which runs from the lower end of the steering column shaft to the right hand end of the tie rod is fitted at each of its ends with a ball and socket joint. Joints of this same type are found at several points on the Ford cars and are used wherever it is desired to make a secure connection that will allow relative motion in almost any direction between the parts attached.

The steering wheel of the Ford car is at the left hand side of the driver's seat and it will be found that this location, rather than that on the right, gives certain advantages in handling the car on the road. For instance, in passing a car coming from an opposite direction it is possible to accurately judge of the clearance between the two cars as they pass. It is also possible for the passenger riding with the driver to alight directly on the curb with the car stopped on the right hand side of the street, whereas, with a right hand location of the steering wheel it would be necessary for the passenger to get out on the left and walk around the car.

#### - BRAKING SYSTEM

Two separate and distinct brakes are provided on the Ford car. One of these brakes acts on a drum carried with the transmission gearing and is called the service brake. This brake is operated by the right hand foot pedal.

The other brake acts directly on the rear wheel hubs through drums fastened to the hubs and into

which brake shoes are expanded when a pull is exerted on rods which attach to the hand lever in the driver's compartment. This wheel brake is called the emergency brake.

The parts of the emergency brake are shown in Figure 36 and consist simply of the steel drum which is solidly fastened to the wheel and two shoes which

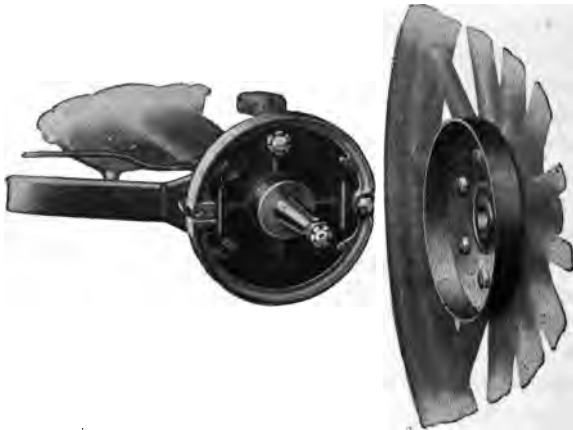

Figure 36.—The Rear Wheel Brake.

expand inside of this drum. The service brake is carried in the transmission and consists of a band which encircles a drum and of a foot pedal which acts to contract the band through linkage drawn tight when the pedal is pressed.

The service brake retards the motion of the car through its effect first on the transmission shaft, then on the universal joint and the drive shaft, then through the rear axle driving gears and differential to the axle shaft and to the wheels.

The differential serves to divide the braking effort equally between the right hand and left hand wheels and in this way serves the purpose of what would be called a brake equalizer were such a device built as a separate part of the braking system. The division between the rear wheels of the braking effect exerted by pulling on the hand lever is not determined by any equalizing device, but depends for equal action on maintenance of correct length of the pull rods. The effective length of these pull rods may be altered by screwing the forked rod ends one way or the other on the ends of the pull rods.

It is possible to apply a powerful braking action at the rear wheels by exerting a very light pressure on the reverse brake pedal. It should, however, be borne in mind that braking done by means of the reverse imposes a very severe strain on the transmission gears.

It is always possible with any car to allow the engine itself to act as a brake in descending a hill of some length. This is done by turning the ignition switch to the off position, closing the throttle and then engaging either high or low gear. The engagement of high gear will cause the car to drive the engine at a moderate rate of speed and this will require sufficient power to reduce the speed at which the car is traveling. Engagement of low speed causes the car to drive the engine very fast and will therefore reduce the speed of the car very quickly. Under the steering wheel are two small brass levers as shown in Figure 37. The right hand or throttle lever controls the amount of gasoline and air mixture which goes into the cylinders. When the engine is in operation the farther this lever is moved downward toward the driver the faster

the engine will run and the greater will be the power furnished.

The left hand lever controls the spark which ignites the gas in the cylinder of the engine. This lever advances the spark and it should be moved toward the driver notch by notch, until the engine reaches its maximum speed with a given throttle opening. If the

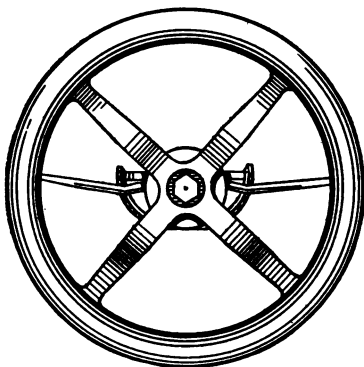

Figure 37.—Spark and Throttle Levers Under Steering Wheel.

lever is advanced or moved toward the driver beyond this point a dull knock will be heard in the engine.

The spark lever should usually be put in about the third or fourth notch of the notched half-circle on which the levers operate. The throttle should usually be opened about five or six notches. A little experience will soon indicate where these levers should be placed for proper starting. Care should be taken while cranking not to move the spark lever too far down as the engine may kick back in starting.

Good drivers keep the spark lever advanced just as

far as the engine will permit without knocking. If the spark is advanced too far ignition occurs before the piston in the engine has completed its compression stroke and a knock results. The best results are obtained when complete ignition occurs just at the time the piston reaches its highest point in the cylinder, the gas then being at its highest compression. The spark should be retarded only when the engine slows down on a bad road or steep grade, but care should be exercised not to retard the spark too far, for when this is done, instead of getting a powerful explosion, a slow burning of gas with excessive heat will be the result. The spark should be operated as the occasion demands. The greatest economy in gasoline consumption is obtained by driving with the spark advanced sufficiently to obtain the maximum engine speed for the throttle opening being used.

The different speeds required to meet road conditions are obtained by opening or closing the throttle. Practically all the running speeds needed for ordinary travel are obtained on high gear and it is seldom necessary to use low gear except to give the car momentum in starting. The speed of the car may be temporarily slackened while driving through crowded traffic or turning corners by slipping the clutch, that is, pressing the clutch pedal forward toward neutral.

#### DRIVING

All of the parts by means of which the driver is given control of the Ford car are shown in Figure 38 as they would appear to a person looking over the back of the front seat. These are the parts with which the driver is concerned after the car is in



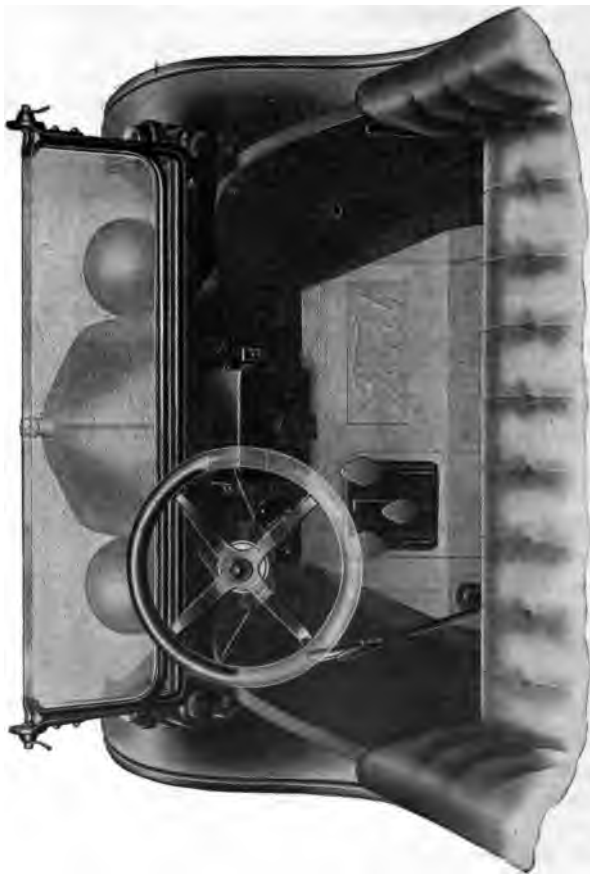

Figure 38.—The Control Members in the Driver's Cab.

motion, but before this time comes it is necessary to make certain preparations to crank the engine and to start the car from a standstill.

Before trying to start the car, fill the radiator with clean, fresh water. If perfectly clean water cannot be obtained it is advisable to strain it through muslin or some similar material to prevent foreign matter from getting in and obstructing the tubes of the radiator. The cooling system will hold a little more than three gallons of water. It is important that the car should not be run under its own power unless the water circulating system has been filled. Pour in the water until both radiator and cylinder water jackets are full. The water will run out of the overflow pipe when the entire water system has been properly filled. The water supply should be replenished as often as may be found necessary. Soft rain water, when it is to be had in a clean state, is superior to hard water, which may contain alkalies and other salts which tend to deposit sediment and clog the radiator.

The gasoline tank should be filled nearly full and the supply should never be allowed to get low. The gasoline may be strained through chamois skin to prevent water and other foreign substances from getting into the tank. Dirt or water in the gasoline is sure to cause trouble. When filling the tank there must be no naked flames within several feet, as the gasoline vapor is extremely inflammable and travels rapidly. Always be careful about lighting matches near where gasoline has been spilled as the air within a radius of several feet is permeated with the highly explosive vapor. The small vent hole in the gasoline tank cap should not be allowed to get plugged up, as this would prevent proper flow of gasoline to the carburetor. The

gasoline tank may be drained by opening the pet-cock in the sediment bulb at the bottom.

Upon receipt of the car see that a supply of medium light, high-grade engine oil is poured into the crankcase through the breather pipe which is covered by a metal cap at the front of the engine. After the engine has become thoroughly limbered up the best results will be obtained by carrying the oil at a level midway between the two cocks, but under no circumstances should it be allowed to get below the lower cock. It will be well to see that all grease cups are filled and that oil is supplied to necessary parts.

Before cranking the engine see that the hand lever, which comes up through the floor of the car at the left of the driver, is pulled back as far as it will go. In this position the lever holds the high speed clutch out of engagement and applies the hub brake, thus preventing the car from moving forward when the engine is started. After inserting the switch key in the switch on the coil box throw the switch lever as far to the left as it will go, to the point marked MAG. This switch connects the magneto with the coils and spark plugs. The engine cannot be started until the switch is closed. Throwing this switch back to a vertical position stops the engine.

*Cranking the Engine.*—The engine is cranked by turning the starting crank which is at the front of the car. Take hold of the handle and push firmly toward the car till the crank ratchet is felt to engage, then lift upward with a quick swing. With a little experience this operation will become an easy matter. Do not, as a usual thing, crank downward, for an early explosion may drive the handle vigorously backward.

This does not mean, however, that it is not advisable, when the car is hard to stop, to occasionally spin the engine by the use of the starting handle, but the spark lever must surely be retarded when spinning, or cranking the engine against compression, otherwise a sudden backfire may injure the arm of the operator. When the engine is cool it is advisable to prime the carburetor by pulling on the small wire at the lower left corner of the radiator while giving two or three quarter turns with the starting handle.

To facilitate starting many drivers make a practice of stopping their engine by walking around in front of the car and pulling out on the priming rod, which has the effect of shutting off the air suction and filling the cylinders full of a very rich gasoline vapor. This should not be done unless the car is going to stand over night or long enough to cool off. If the engine is stopped in this way and then cranked while still hot, starting is apt to be difficult on account of the surplus gasoline in the cylinders.

The carburetor does not ordinarily require priming when the engine is warm, and cranking with the rod pulled out is apt to flood the engine with an over-rich mixture of gas which does not readily explode. This naturally causes difficulty in starting. If the cylinders should be accidentally flooded, turn the carburetor adjusting needle down or to the right until it seats; then crank the engine for a few revolutions in order to exhaust the rich gas. As soon as the engine starts, turn the needle back and readjust the carburetor.

*Starting the Car.*—In order to allow the engine to be started with the car standing still, a position of the change speed gearing is provided which allows the engine to run without moving the road wheels. This

is called the neutral position. In order to give sufficient power for starting the car, another position is provided in which the engine will turn very fast and deliver a large amount of power while the car moves slowly.

To engage the gearing in the position for starting, usually called low speed, the driver presses gently on the left hand pedal until the power of the engine applied through the gears causes the driving wheels to revolve slowly. The band is allowed to slip slightly so that the engine can keep up its speed and at the same time begin to move the car.

As the pressure on the pedal increases there will be less and less slipping of the band and the car will run faster until its speed reaches a point as great as the engine will drive it with the change speed gearing in the low speed position.

After starting the car from a standstill in this way the pedal is released by the driver and the clutch is allowed to engage gradually so the car will go faster than before, but of course without as great power.

The operation of the foot pedals has already been explained. The first one toward the left operates the clutch and by it the car is started and its operation largely controlled. When pressed forward the clutch pedal engages the low speed gear. When half-way forward the gears are in neutral—that is, disconnected from the driving mechanism of the rear wheels. With the hand lever thrown forward, releasing this pedal so that it comes back, it engages the high-speed clutch. The center pedal operates the reverse band and gears. The right-hand pedal operates the transmission brake.

In starting, slightly accelerate the engine by open-

ing the throttle, place the foot on the clutch pedal, and thereby hold the gears in a neutral position while throwing the hand lever forward. Then to start the car in motion, press the pedal forward into slow speed and when under sufficient headway allow the pedal to drop back slowly into high speed, at the same time partially closing the throttle, which will allow the engine to pick up its load easily. With a little practice the change of speeds will be easily accomplished, and without any appreciable effect on the smooth running of the machine.

The chief purpose of the hand lever is to hold the clutch in neutral position. If it were not for this lever the driver would have to stop the engine whenever he left the driver's seat. He would also be unable to crank the engine without the car starting forward with the first power stroke. When pulled back as far as it will go, the hand lever acts as an emergency brake on the rear wheels by expanding the brake shoes in the wheel drums. Therefore the hand lever should be back as far as it will go when cranking the engine or when the car is at rest. It should be in a vertical position and not far enough back to act as a brake when the car is to be reversed. When the car is operating in high or low speed the hand lever should be all the way forward.

*Stopping.*—To stop the car, partially close the throttle, release high speed by pressing the clutch pedal forward into neutral and apply the foot brake slowly but firmly until the car comes to a dead stop. Do not remove the foot from the clutch pedal without first pulling the hand lever back to neutral position or the engine will stall. To stop the engine, open the throttle a trifle and then throw off the switch. The

engine will then stop with the cylinders full of explosive gas which will naturally facilitate starting.

The driver should be so familiar with the operation of the car that to disengage the clutch and apply the brake becomes practically automatic, the natural thing to do in case of emergency.

In driving down long, steep hills the speed of the car may be checked by allowing the engine to run against compression with the ignition off rather than by using the transmission brake. Throw off the switch and close the throttle. If this does not slow the car sufficiently, press on the low-speed pedal. Upon reaching the bottom of the incline, throw on the switch and open the throttle when the engine will commence firing. If the throttle is left open while descending the hill fresh gas is apt to work back through the exhaust pipe and cause an explosion in the muffler when the switch is thrown on. Using the engine as a brake should not be undertaken until the driver becomes thoroughly familiar with the car.

It will often be found, when stopping in a street, that it is necessary to drive into a space, usually between two other cars, which is not much longer than the car which you are driving. The path to be taken in getting into such a space is shown in Figure 39. The path of the front wheels is shown and this path should be made such that the right-hand side of the car is brought as far toward the curb as possible in the space between the two cars and is then made to pass the rear corner of the standing car, marked A, with just as little clearance as is safe. It will then be found that upon backing, the rear end of your car will approach the curb and finally by turning the steering wheel sharply as soon as your front fender

clears the car marked *A*, your car will be lined up nearly parallel with the curb.

The brakes should never be applied with such great force as to cause the rear wheels to come to a complete stop and slide along on the ground. With the wheels locked the car will not come to a stop nearly so quick as while they turn and keep their hold on the road surface. Should the wheels inadvertently be locked,

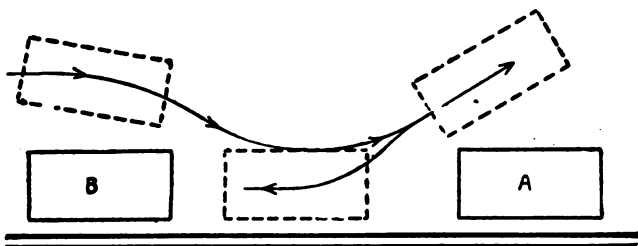

Figure 39.—Path to Be Taken in Driving Between Cars at Curb.

the brakes should be immediately released and then re-applied more gently so that the tires retain their grip on the road, yet exert all the retarding effort that is allowed by the weight of the car.

*Skidding.*—Skidding is best prevented by keeping off slippery pavements whenever possible. Drive slowly when on them. In wet and snowy weather use chains on the rear wheels, and if the mud or snow is very bad, on all four wheels. Apply the chains loosely so they will move about and distribute the wear over the entire surface of the casing. Non-skid tires may help some. When the car starts to skid, do not apply the brake, but close the throttle and turn the steering wheel in the direction in which



the rear wheels are sliding. This will tend to neutralize the lateral movement of the car.

If, in the absence of chains, the car becomes mired, or the road is so slippery that the wheels cannot secure sufficient hold to move the car, relief may be obtained by winding a rope around the rear tires and between the spokes.

The greatest care should be exercised on or near car tracks because the tendency of wet rails is to carry the automobile wheels along in the grooves no matter which way you turn the hand wheel, and when the front wheels finally leave the rails the car will be deflected so violently that it will make a bad skid almost a certainty.

It will be found that the different paving materials, when wet, provide different experiences for the driver. A wood block pavement is a most treacherous surface, and, unless extreme caution is used, the wheels will travel in almost any direction except the one desired. Asphalt pavement probably ranks next in slipperiness. Cobble stone comes next and brick last. In other words, a brick pavement is comparatively safe to drive on even when wet. A mud road is not especially dangerous for a car running at a moderate speed, and is only to be avoided because of getting into the mud so deep that there is not sufficient traction to pull out.

While driving on a wet road that is crowned or raised at its center, skidding may be avoided by running with the two wheels on one side of the car in the gutter. This will tend to carry the car along in the trough formed between the edge of the road or the curb of the street and the depression made for the gutter.

In case a skid starts in spite of all care that may be used, it is essential that the brakes should not be applied unless it is absolutely necessary to retard the car to avoid an accident. When the brakes are applied with the car running on a wet pavement, one wheel is almost sure to receive a greater retarding effort from the brakes than that received by the other. This one wheel will come to a stop and the car will tend to spin around on this wheel's contact with the road as a center. This kind of skidding may be prevented in large measure by leaving the high speed clutch engaged whenever the brakes are applied on a wet road. The engine effect, through the driving parts, will keep both wheels turning, but the brakes will bring the car speed lower and lower until, just before the engine would stop because of the braking, the clutch may be released, and the final part of the stopping done with the brakes as in ordinary practice.

*Reversing.*—The car is reversed by first coming to a dead stop. With the engine still running, disengage the clutch by pulling back on the hand lever and press the reverse pedal forward with the left foot, the right foot being free to use on the brake pedal if needed. Do not bring the hand lever back too far or the brakes will be set on the rear wheels. Experienced drivers ordinarily reverse the car by simply holding the clutch pedal in neutral with the left foot while operating the reverse with the right.

A considerable amount of practice is required in order to drive a car backward, and this is especially true of turning corners or of backing down a hill. It will be found that once the car starts to turn it will leave a straight line very quickly and will show a

decided tendency to get beyond the control of the driver. It is almost impossible for an inexperienced driver to look back of him and at the same time keep the car running in a straight line. It might be noted that this difficulty is encountered whether the car is traveling forward or backward, and oftentimes leads to very serious consequences.

Speeding harms any car—particularly a new one. The Ford has all the power and speed necessary for safe and comfortable travel. But excessive speed is expensive, it shortens the life of both tires and machinery and besides, it is dangerous. The best car made will not long withstand the strain of unreasonable driving. Racing cars are short lived.

A decided difference will be found between driving on the city pavements and on country roads. While driving in the city it is best to have the steering gear so adjusted that there is little or no play because it is desirable to follow an unwavering path, and that path is determined solely by the movement or lack of movement of the steering wheel. On a country road it will be found that the ruts or tracks serve in a great measure to guide the front wheels of the car and steering is not nearly so difficult. In driving on a country road it will be sufficient if the steering wheel is held rather loosely so that the road wheels are free to follow the traveled tracks.

While driving in traffic and while approaching corners it is very necessary to keep the car under such control that accidents may be avoided. This may best be done by running at such a speed that the car could be brought to a stop in the distance between it and whatever vehicle is next ahead. This would of course allow for an almost instantaneous stop if the

car or wagon ahead should stop because of a collision, for example.

When approaching a corner the speed should be such that it would be possible to come to a stop before crossing the intersecting street, and to do this in the time remaining between the instant at which you might catch sight of another car crossing your path and the time at which your car would reach the street intersection.

In turning a corner, whether at the intersection of another street or road or where the road on which you are traveling turns, it should be made a habit to follow a path that always keeps your car on the right-hand side of the center line of the road or on the right of a point where the center line of two intersecting thoroughfares cross each other. This will result in turning a long corner when the turn is made to the left because in going around the center point you will have to keep to the right-hand side which is the outside of the curve. When turning to the right a short corner will be turned because you will follow the inside of the curve. Such a procedure is a matter covered by police regulations in most cities, but it is wise to follow this method at all times so that the possibility of accidents may be avoided.

In many localities it will be found that traffic on certain streets has the right of way over traffic on intersecting streets. It is generally found that traffic on boulevards and street car lines has the right of way over streets that cross, and in some cities it will be found that north and south bound traffic has the right of way over east and west, or vice versa. There is an old rule, seldom noted, that says right-hand traffic has the right of way on country roads. Tl

means that another car which will cross the road on which you are traveling should be allowed to cross in front of your car provided the other car is approaching from your right, while if it is approaching from your left you are supposed to cross first. This rule is not generally enough known to make it safe to depend on the other driver's knowing and obeying it.

When it is necessary to climb a rather steep hill it is generally best to increase the speed of your car until it reaches about twenty miles an hour, and if this is done it will usually be found possible to climb any ordinary grade with the high speed clutch engaged. This advice would not apply unless the road leading up the grade is free from sharp curves so that it may be seen for a considerable distance ahead. As the engine slows down in making the climb, the spark lever should be retarded or pushed away from the driver a notch at a time and the throttle lever should be left in a wide open or a nearly wide open position. If the car runs almost to the top of the incline in high gear, but seems to be slowing down to such an extent that the summit cannot be reached, it will generally be possible to finish the climb on high gear if the clutch pedal is pressed a little so that the plates in the clutch are allowed to slip a trifle and thus allow the engine to again increase its speed and power while keeping up the application of driving effort to the rear wheels. This slipping of the clutch should not be indulged in for more than a very short distance as it will damage the mechanism and it is very easy to press the pedal forward into low speed for whatever distance remains on the hill being negotiated.

In climbing a very steep hill it may be found that the fuel supply in the tank has reached such a low level that it will no longer flow to the carburetor because of the fact that the inclined position of the car brings the carburetor bowl higher than the bottom of the gasoline tank. Should such a thing happen, the hill may be surmounted by turning the car around and backing up because this reversed position will bring the bottom of the tank much higher than the carburetor—in fact, it will be higher in proportion to the steepness of the grade.

In coasting down hill the car may easily attain a speed much in excess of the one at which the driver thinks he is traveling. This speed will be realized when the brakes are applied, because if either the right or left hand brake is tighter than the other one, one of the wheels will lock and a more or less serious skid will almost inevitably result.

The driver of a car should familiarize himself with the local police and traffic regulations of the town or city in which he operates a machine. Some of these regulations are in force in all localities. Among these are the rules: Keep to the right. In passing a car going in your direction, go to the left. Always be prepared to meet emergencies. Do not cut diagonally across the street. Hug the curb in making the short turn at a corner. Always go around the center of the street intersection in making the long turn. Extending the arm to the right or left will indicate to the driver behind the direction in which you expect to turn.

It is sometimes a question in a driver's mind just how to pass over a section of road that has been freshly covered with loose sharp gravel which pre-

sents many cutting edges and points to the tires. If the troublesome part of the road is very long it will be best to come down to a moderate speed and then maintain this speed with as little use of the throttle, clutch and brakes as is possible until the stones have been passed. Quick stops or quick acceleration will increase the liability of damage to the tires. If the stretch of stony road is comparatively short the tires will receive the least damage if the car speed is increased to a moderate extent so that, when the stones are reached, the clutch may be released and the car allowed to coast over the bad part of the road on its own momentum and without the application of either brakes or power.

The driver may sometime find himself in the predicament of having a tire so damaged that it is impossible to make a roadside repair, and at the same time be without a spare tire of any kind. This means that the car must either be left where it is or else driven in on the rim and without any tire. If the casing is so badly damaged that it will be of no further use anyway, it will be best to remove the tube, if this is not considered too much work, and to then drive along very slowly with the casing replaced on the rim. The casing will probably become so loosened within a short time that it will come off the rim, but it will stay on much longer without the tube than with it. Should it be found that the casing is worth an attempt to save it so that future repairs may be made, it should be removed from the rim, after which the car may be slowly driven with the rim itself rolling on the roadway. This will often be the best thing to do because a wheel does not cost nearly as much as a new casing. Running for any distance

on the rim will tend to loosen the wheel spokes in the hub and felloe and also to damage the rim.

Whenever it becomes necessary to tow another car, or when it is necessary for your car to be towed by another, care should be exercised as to the selection of a point for attaching the tow line to both cars. The line should be attached to the towed car at the front axle and rather near one of the spring supports rather than at the center. The line should be attached to the towing car around the rear axle and at a point near one of the spring supports. It is generally best to use a rope or line that will allow a distance of about fifteen to twenty feet between the cars, as this will allow the driver of the towed car to check the motion of his car in time to avoid collisions with the one ahead. The danger of a long tow line is that persons crossing the street or road on which the cars are traveling may accidentally fall across the tow with imminent danger of being run over by the rear car.

Caution should be used by the driver of the towing car when the slack is first taken out of the tow line, because if this is done too suddenly the front axle and the axle connections of the towed car may suffer damage. It should be the aim of both drivers, after their cars are under way, to keep the slack out of the tow line so that sharp jerks may be avoided. This may be done by the forward car's maintaining an even speed and by a judicious use of the brakes by the driver of the car being towed. Extreme care should be used when two cars thus fastened together are crossing intersecting streets and when they are turning corners, and it will be advisable to be ready to make free use of the horn. A code of signals . . .



ried out with the use of the horn will be found a convenience in advising the other driver when it is desired to start, to stop or to proceed carefully.

Accidents of various kinds may happen to anyone and they may happen to you. The most common accident is a collision with another automobile or with a railroad car. A word of advice may be given that in case of an impending collision and when it is impossible to avoid it, steer your car in the same direction that the other vehicle is moving. This will minimize the force of the impact and will probably prevent anything more serious than bent fenders or a jammed body.

#### COLD WEATHER PROCEDURE

As gasoline does not vaporize readily in cold weather, it is naturally more difficult to start the engine under such conditions. The usual method of starting the engine when cold is to turn the carburetor dash adjustment one-quarter turn to the left in order to allow a richer mixture of gasoline to be drawn into the cylinders; then hold out the priming rod which projects through the radiator while you turn the crank from six to eight quarter turns in quick succession.

Another method of starting a cold engine is as follows: Before throwing on the mangeto switch, close the throttle lever and hold out the priming rod while you give the crank several quick turns. Then let go of the priming rod and make sure that it goes back all the way. Now place the spark lever in about the third notch and advance the throttle lever several notches. Turn the switch to the side marked Mag-neto and give the crank one or two turns, when the

engine should start. After starting the engine it is advisable to advance the spark eight or ten notches on the quadrant and let the engine run until thoroughly heated up. If you start out with a cold engine you will not have much power and are liable to stall. The advantage of turning on the switch last, or after priming, is that when you then give the crank one-quarter turn there is plenty of gas in the cylinder to keep the engine running, thereby eliminating the trouble of having the engine start and then stop. After the engine is warmed up, turn the carburetor adjustment back one-quarter turn.

Starting is made much easier by the introduction of liquid fuel into the combustion space of the engine. In the case of a Ford car equipped as it leaves the factory this may only be done by removing the spark plugs and injecting a small amount of gasoline, then replacing the plugs before cranking the engine. This method entails considerable effort and delay and the same result may be accomplished if the engine is equipped with a type of spark plug which is fitted with a small pet-cock or priming cup. This priming cup may be opened and the fuel injected very easily. In extreme cold weather it may be found that the grade of gasoline now being furnished does not vaporize readily enough to start the engine, even when the liquid is placed in the combustion chamber. In this case it will be found that a very few drops of ether will do the work.

The circulation of water in the Ford cooling system does not commence until the water becomes heated and it is apt to freeze at low temperatures before circulation commences. The best way to avoid such troubles is to use an anti-freezing solution in the

radiator and cooling system. Either wood or denatured alcohol will lower the freezing point of the liquid. The following table gives the freezing point of solutions containing various percentages of alcohol:

20% solution freezes at 15 degrees above zero.

30% solution freezes at 8 degrees below zero.

50% solution freezes at 15 degrees below zero.

A solution composed of 60% water, 10% glycerine and 30% alcohol is commonly used, its freezing point being about 8 degrees below zero. On account of evaporation, fresh alcohol must be added frequently in order to maintain the proper solution.

Glycerine and alcohol mixed in equal quantities is a handy liquid for preventing rain from accumulating on the windshield of a car. A small amount rubbed on the windshield will cause the rain to run off as rapidly as it strikes the glass.

## CHAPTER IV

### UPKEEP AND CARE

The appearance and value of the car may be greatly enhanced by giving it proper care at all times. A great part of this care consists in lubrication and cleanliness. The easiest way to give this care is to do it systematically; that is, to plan the work that must be done and then to follow this plan conscientiously. The following system has been designed for the Ford car, and, if it is followed, the results will well repay the owner for the time spent. The points which require lubrication are shown in Figure 40.

There are certain things that should be done at regular intervals, and, for convenience, these things have been classified into those that should be done every day, those that should be done every fifty miles, every two hundred, every four hundred, every twelve hundred and every five thousand miles that the car is driven.

Every day the car is run, oil should be put into the engine through the breather pipe at the front and on the right-hand side. Oil should be added until it reaches some point above the lower pet-cock on the flywheel housing, but not above the upper pet-cock.

#### EVERY FIFTY MILES

Every time the speedometer reaches a total mileage which is a multiple of fifty, the driver should raise the hood and make a careful examination for oil, water, or gasoline leaks at any of the pipes or joints.

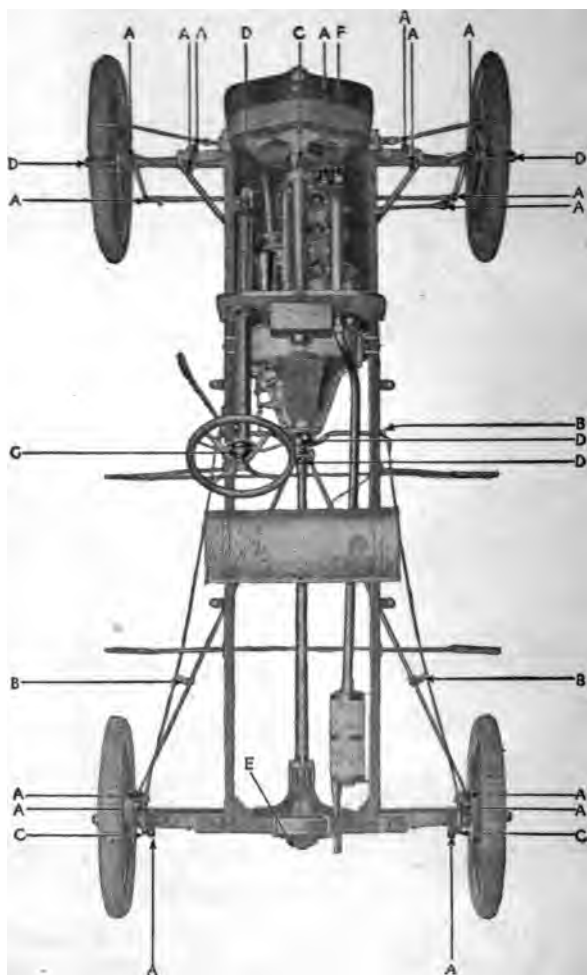

Figure 40.—Oiling Chart for the Ford Car: A, Oil Every 200 Miles; B, Oil Every 500 Miles; C, Grease Every 200 Miles; D, Grease Every 500 Miles; E, Grease Every 1,000 Miles; F, Oil Motor Daily; G, Grease Every 5,000 Miles.

The rear wheels should be jacked clear of the ground and should then be grasped and pulled back and forth to make sure that they are tight on the tapered end of the axle shaft. Should any play be noticed, the hub cap should be removed and the nut tightened or else the key replaced with a new one.

The front wheels should then be jacked up and tested, not only for smoothness of running, but for side play as well. If in spinning a front wheel a sharp click occurs now and then, the wheel is momentarily checked, it is probable that there is a chipped or split ball in the bearing and it should be removed and replaced with a new one, otherwise it may necessitate the renewal of the entire bearing. A wheel in perfect adjustment should, after spinning, come to rest with the tire valve directly below the hub. Undue wear in the hub bearing, such as in the cones, balls and races, is usually caused by lack of lubrication and excessive friction due to the adjusting cone being screwed up too tight. It is a good plan to clean the bearings frequently and keep the hub well filled with grease.

#### EVERY TWO HUNDRED MILES

The following points should be oiled at this time: the front spring shackle oil caps; the steering spindle bolts; the three ball and socket joints on the steering rods; the rear wheel hub brake cams and the rear spring shackle oil caps. Either oil or vaseline should be put into the commutator at this time, the method being shown in Figure 41.

Keeping the commutator well oiled is a matter of far greater importance than many drivers realize and is necessary in order to have a smooth operating en-

gine. Don't be afraid to put a little oil into the commutator every few days, or at least every two hundred miles. Remember that the commutator roller revolves very rapidly, and without sufficient lubrication the parts soon become badly worn. When in this condition perfect contact between the roller and the four



Figure 41.—Oiling the Commutator.

contact points is impossible and as a result the engine is apt to misfire when running at a good rate of speed.

At the time this oiling is done the grease cup on the fan hub should be given a turn or two, as should all of the grease cups on the rear axle. Also see that the ball and socket joints on the steering gear are tight.

A mixture should be made of three-fourths kerosene and one-fourth alcohol and about one-half cup

of this mixture should be put into each cylinder of the engine while it is still hot, and at the end of each two hundred miles running. This mixture will loosen any carbon deposit if allowed to remain over night.

#### EVERY FOUR HUNDRED MILES

It is advisable to clean out the crankcase by draining off the dirty oil when a car has been driven four or five hundred miles; thereafter it will only be necessary to repeat this operation about every thousand miles. Remove the plug underneath the flywheel casing and drain off the cylinder oil. Replace the plug and pour a gallon of kerosene in through the breather pipe. Crank the engine by hand fifteen or twenty times, so that the splash from the kerosene will thoroughly cleanse the interior of the engine. Remove the crankcase plug and drain the kerosene. In order to get all the kerosene out of the depressions in the crankcase the car should be run up an incline about the height of the ordinary street curbing. Then fill with fresh oil.

The following points should be oiled at this time: the brake pull rod brackets and the pull rod supports on the side of the frame; the lacing between the engine hood and the hood rest; the starting crank; the door hinges and the door locks.

A light-bodied grease or vaseline should be placed in the front wheel bearings. The grease cups at the bottom of the steering column, the cup on the universal joint and the cup at the front end of the drive shaft should be given one or two turns.

The ball and socket joint underneath the engine and at the rear end of the front axle radius rods should be examined to see that it is tight. The elec-



tric wiring and the lamp connectors should be examined for any looseness. The front and rear axles should be carefully gone over to see that every moving part, such as the bushings in the spring connections, the spring hangers, the steering knuckles and the hub bearings are thoroughly lubricated and that all nuts and connections are secured with cotter pins. The spring clips, which attach the front and rear springs to the frame, should be inspected frequently to see that everything is in perfect order.

Each of the tires should be tested to see that it is properly inflated. More tires give out from insufficient inflation than from anything else. Air costs nothing; tires are expensive. Remember it is the air in the tube that carries the load and cushions the road. The front tires should carry a pressure of fifty to fifty-five pounds and the rear tires sixty to sixty-five. In hot weather the pressure should be about five pounds less than in cold weather on account of the expansion of heated air. To accurately determine the pressure a reliable pressure gauge should be used. In the absence of a gauge, a good rule to follow is the maintenance of sufficient pressure to prevent the tires from bulging out under the weight of the car. Tires should never be run partially deflated, as the side walls are unduly bent and the fabric is subject to stresses which cause what is known as rim cutting.

#### EVERY TWELVE HUNDRED MILES

The belt which drives the fan for drawing air through the radiator should be inspected and tightened if necessary by means of the adjusting screw in the fan bracket. Take up the slack until the fan

starts to bind when turned by hand, but do not make this adjustment too tight.

The entire water circulating system should be thoroughly flushed out. To do this properly the radiator inlet and outlet hose should be disconnected and the radiator flushed out by allowing the water to enter the filler neck at ordinary pressure, when it will flow down through the tubes and out at the drain cock and hose. The engine water jackets can be flushed out in the same manner. Simply allow the water to enter the cylinder head connection and to flow through the water jackets and out at the side connection.

The spark plugs should be kept clean and should be replaced if they persist in not working properly. All wire connections to spark plugs, coil box and commutator should, of course, be at all times kept in perfect contact.

The cover of the commutator should be removed and the inside of this device wiped out with a clean cloth, after which a small amount of vaseline or oil should be added.

The bolts which fasten the engine to the frame should be examined to make sure they are tight and the spring shackle bolts and the spring clips should also be inspected to make sure that none of the nuts have worked loose.

If the spring clips are allowed to work loose, the entire strain is put on the tie bolt which extends through the center of the spring. This may cause the bolt to be sheared off and allow the frame and body to shift a trifle to one side. It is a good plan to frequently inspect the clips which hold the springs to the frame and see that they are kept tight.

Each of the four tires should be examined all the

way around its circumference, and if there are any cuts through the rubber, they should be cleaned out and preferably vulcanized. If they cannot be vulcanized, the small cuts should be filled with some of the special preparations which are on the market for such purposes.

#### EVERY FIVE THOUSAND MILES

The small gears which allow the driver to turn the steering shaft are located at the top of the steering column and just underneath the hub of the hand wheel. By loosening the set screw and unscrewing the brass cap, after having removed the steering wheel, they may be readily inspected and the grease replenished. To remove the steering wheel unscrew the brass nut on top of the post and drive the wheel off the shaft with a block of wood and a hammer.

If the springs are somewhat stiff, take a screw driver and pry the leaves apart near the ends just enough to place a little lubricating oil or graphite between them. You will find that repeating this operation about twice a month will add materially to the riding comfort of the car.

#### SYSTEMATIC UPKEEP

The following tabulation includes all of the items of care which have been mentioned in the foregoing pages and will make a convenient outline for use in caring for the car.

##### *Every Day:*

Put oil through engine filler until it rises above lower pet-cock.

*Every Fifty Miles:*

- Look for oil, water and fuel leaks.
- Shake rear wheels to see that they are tight.
- Shake front wheels to test bearings for looseness.

*Every Two Hundred Miles:*

- Oil the front spring shackles. Z
- Oil steering spindle bolts.
- Oil ball and socket joints on steering rods. (Z)
- Oil rear wheel hub brake cams. Z
- Oil rear spring shackles. Z
- Put vaseline in the commutator.
- Turn grease cup on fan hub.
- Turn grease cups on rear axle. Z
- Test steering gear ball and socket joints for looseness.
- Put kerosene in engine cylinders while hot.

*Every Four Hundred Miles:*

- Oil brake rod brackets and support.
- Oil hood lacing.
- Oil the starting crank.
- Oil the door hinges and locks.
- Turn grease cup at bottom of steering column.
- Turn grease cup on universal joint.
- Turn grease cup at forward end of drive shaft.
- Put grease or vaseline in front wheel bearings.
- Examine wiring for loose connections.
- Examine ball joint under engine for looseness.
- Test the compression of each cylinder with starting crank.
- Test inflation pressure of each tire.

*grease*

*Every Twelve Hundred Miles:*

- Clean spark plugs and set gaps to  $\frac{1}{32}$  inch.
- Clean inside of commutator.
- Flush the cooling system.
- Test the fan belt adjustment.
- Examine engine bolts for looseness.
- Test the spring shackle bolts for looseness.
- Test the spring clip nuts for looseness.
- Test the front wheel alignment.
- Repair cuts in tires.

*Every Five Thousand Miles:*

- Test body bolts for looseness.
- Put grease in gear case under steering wheel.
- Lubricate spring leaves.

If the above outline is followed it will mean that the items under the fifty-mile heading will be cared for every time the speedometer shows that this distance has been traveled. At two hundred miles it will be necessary to go over the points under the two hundred mile heading and also those under the fifty-mile heading, because two hundred is a multiple of fifty. For a similar reason it will be necessary, when the four hundred mile list is cared for, to take care of those specified at two hundred miles as well as of those called for at fifty. At twelve hundred miles the lists for four hundred, for two hundred and for fifty miles should also be gone over, while at the end of five thousand miles all of the items should be checked.

## GENERAL INSTRUCTIONS

A light grade oil is preferred, as it will naturally reach the bearings with greater ease, and consequently

less heat will develop on account of friction. The oil should, however, have sufficient body so that the pressure between the bearing surfaces will not force the oil out and allow the metal to come into actual contact. Heavy and inferior oils have a tendency to carbonize quickly, also to gum up the piston rings the valve stems and the bearings. In cold weather a light grade of oil is absolutely essential for the proper lubrication of the car. Graphite should not be used as a lubricant in the engine or transmission as it will have a tendency to short-circuit the magneto.

When it is advisable to fill the grease cups, screw them down, then refill them with grease and repeat the operation two or three times. Always open oil cups by turning to the right, as this keeps tightening the threads rather than loosening them. Occasionally remove the front wheels and supply grease to wearing surfaces. A drop of oil now and then in the crank-handle bearing is necessary, also on the fan belt pulleys and shaft. The axles, drive shaft and universal joint were well supplied with lubricant when the car left the factory, but it is well to examine and oil them.

Special care should be taken to see that the wiring and other ignition parts are kept perfectly clean, because grease, oil, moisture or dirt on these parts will surely lead to trouble. Whenever the engine is cleaned it is advisable to wash the radiator both from the front and from the back to remove any accumulations of mud or dust, which are very detrimental to the action of this part of the car.

When putting the top down be careful in folding to see that the fabric is not pinched between the bow spacers, as they will chafe a hole through the top

very quickly. Always slip the hood over the top when folded to keep out dust and dirt. Applying a good top dressing will greatly improve the appearance of an old top.

The top should be raised occasionally and allowed to remain up for a while so that the creases which finally end in cracks may be avoided. The top should never be folded while it is still damp.

In washing the car always use cold or lukewarm water, never hot water. If a hose is used, don't turn the water on at full force, as this drives the dirt into the varnish and injures the finish. After the mud and grime have been washed off, take a sponge and clean the body and running gear with a tepid solution of water and Ivory or linseed oil soap. Then rinse off with cold water, rub dry and polish the body with a chamois skin. A body or furniture polish of good quality may be used to add lustre to the car. Grease on the running gear may be removed with a gasoline-soaked sponge or rag. The brasswork may be polished with any good metal polish. A satisfactory body polish may be made from four to five parts of kerosene and one of gasoline.

Tire cost constitutes one of the most important items in the running expense of an automobile. To get the most service at the least expense the tires should be inspected frequently and all small cuts or holes properly sealed or repaired, thus preventing dirt and water from working in between the rubber tread and the fabric and causing blisters or sand boils.

The chances of getting a puncture will be greatly reduced by keeping the tires properly inflated, as a hard tire exposes much less surface to the road than

a soft tire, and also deflects sharp objects that would penetrate a soft tire. Running a tire flat, even for a short distance, is sure to be costly. It is better to run on the rim, very slowly and carefully, rather than on a flat tire. Remember that fast driving and skidding shorten the life of the tires. Avoid locking the wheels with the brakes, because no tire will stand the strain of being dragged over the pavement in this fashion. Avoid running in street car tracks, in ruts, or bumping the side of the tire against the curbing. The wheel rims should be painted each season and kept free from rust.

When a car is idle for any appreciable length of time, it should be jacked up to take the load off the tires. If the car is laid up for many months it is best to remove the tires, wrap up the outer casings and inner tubes separately and store them in a dark room which is not exposed to extreme temperatures. Remove oil or grease from the tires with gasoline. Remember that heat, light and oil are three natural enemies of rubber. The wear on the tires may be evenly distributed by shifting those on the right side to the left at the end of about one thousand miles running.

Spare inner tubes should be properly folded and cared for. First remove the valve plunger so it is possible to expel all the air from the tube, then replace the plunger and lay the tube flat on the floor or ground with the valve in the middle pointing upward and equidistant from the two folded ends. To do this it is necessary to turn the tube with that side outward that lies next the rim when in use. Fold the ends upon themselves with the outermost parts brought up to the valve and then laid flat. A second fold is then



made by picking up the two outer folds and bringing them together and at the same time lifting the tube from the ground. The tube will then lie in four flat folds with the valve projecting upward between them at the bottom. A stout rubber band snapped over the outside will hold the tube in proper shape.

#### LUBRICATION

The oil used to lubricate the gasoline engine is obtained by distilling crude petroleum. This distillation results in the separation of gasoline, kerosene and various grades of lubricating oils among many other products.

The quality of this oil is subject to test by a number of standards, several of which will be mentioned because of the fact that they are often brought up while buying and selling these lubricants. The quality most often mentioned is that called viscosity. Viscosity might be translated by the word thickness. Viscosity is generally expressed in the time required for a certain quantity of oil to pass through a given sized opening. An oil having high viscosity will require a longer time to pass through this opening than will one of low viscosity. An oil of high viscosity is generally called heavy, while one of low viscosity is classed as a light oil. Another standard is known as gravity, and this means the weight of a given volume of the oil as compared with the weight of an equal volume of water. The gravity of an oil is not of as great importance as is the viscosity.

The degree of heat at which the oil is consumed is measured according to two standards. The first is called the flash test, and this is the number of degrees in temperature at which the vapor given off by the oil

will take fire when a flame is applied. The fire point of the oil is the temperature at which the body of heated lubricant will take fire and continue to burn. There is a third temperature test called the cold test, and this is the point at which the oil becomes so thick from cold that it can no longer be readily poured.

The carbon content of an oil is determined by evaporating a certain quantity of the lubricant with heat until nothing is left but a solid deposit in the vessel from which the evaporation has taken place.

This deposit is weighed and compared with the original weight of the oil being tested. This standard does not necessarily give any indication of the amount of carbon that will be left in a gasoline engine by the use of the oil being tested.

The color of the oil as compared with some standard color is not a reliable indication of any of its lubricating qualities.

It is hard for the motorist to determine the practical value of the standards just mentioned in purchasing oils. The flash and fire tests are of course valuable and both should be rather high. An oil having a flash point much below 400 to 450 degrees Fahrenheit will show a considerable loss from evaporation, due to the heat in the crankcase of the engine. An oil having a low fire point will be easily separated into elements which differ radically from the original lubricant. It is not to be expected that any lubricating oil will have a fire test sufficiently high to resist the heat found in the combustion space of the engine.

The viscosity of the oil should be just high enough to keep a film between the moving surfaces in the engine and between the surfaces of the bearings and the journals which revolve inside of them.

An oil heavier than this will materially reduce the power of the engine because of friction between its particles, while a lighter oil will not allow the engine to deliver its full power. When an engine becomes badly worn it is desirable to use an oil having a comparatively heavy body which provides cushion between the parts and reduces the noise. The most desirable oils for general use are those having a Saybolt viscosity of between 200 and 300 seconds.

The carbon content of an oil will vary almost directly with its viscosity, that is, a heavy oil contains a greater portion of fixed carbon than does a light oil. This brings out a serious objection to using a heavy oil even in a badly worn engine, because in such an engine there is sufficient clearance between the pistons and the cylinder walls to allow a considerable quantity of the oil to work up into the combustion chamber, and with a heavy oil in use, this will result in a greater carbon deposit than would be the case with a light oil. This would indicate that a rather light bodied oil should be used under all conditions.

The cold test is of value only as compared with the temperatures generally prevailing in the locality in which the car is being used. When the car stands idle, all of the parts of the engine, which of course include the lubricating system, will reach the temperature of the atmosphere, and if this temperature is below the point at which the oil congeals, then there will be danger that no lubricant will flow to the moving surfaces until after the parts have warmed up. Otherwise the cold test of an oil has no bearing on its lubricating qualities.

The attention of Ford users should be called to the fact that it is not safe to introduce graphite as a lubri-

cant into the engine because the same oil which passes through the engine system also serves to lubricate the transmission and the clutch. The action of graphite is to fill the small indentations of a surface so that it becomes perfectly smooth and very slippery at all points. This condition would be highly undesirable in the transmission bands and under some conditions on the clutch discs, and would obtain were the bands and their drums to be covered with graphite. It would then be almost impossible to draw them tight enough to hold and to drive the car. Graphite may be safely used in any combination in the rear axle, in the front wheel bearings, in the steering gear or at any other point on the car where there will be no danger of its reaching the clutch or transmission.

#### CARBON

The carbon deposit which is often found in the combustion space of an engine consists in part of road dust and other impurities drawn in through the carburetor and also includes a considerable amount of true carbon which has resulted from the incomplete combustion of the gasoline and air mixture and the burning of that part of the lubricating oil which has found its way past the rings and into the space above the piston.

A condition which contributes materially toward the increase of carbon deposit is that of poorly fitted and leaking piston rings. Such a condition makes it impossible for the lubricating oil to seal the space between the piston and the cylinder walls, and the result is that an excess of oil is drawn up into the combustion space during the inlet stroke when there is a partial

vacuum and a considerable suction in this part of the engine.

Carbonization of the engine will always result from the use of a poor grade of oil and it will also result from the use of an oil which is either too light or too heavy. Carrying the oil level so high that the exhaust becomes smoky every time the engine is raced will also do its part toward increasing the amount of carbon.

After a certain amount of this carbon has been deposited on the walls of the combustion chamber it acts to materially reduce the volume of the compression space and the resulting increase of pressure at the end of the compression stroke tends to make the engine more liable to pre-ignition. An engine will stand quite a deposit of carbon without the compression being raised to a dangerous point, but if the deposit increases beyond this point trouble will follow and will manifest itself in knocking at low speed and whenever the engine is pulling hard.

After the carbon deposit reaches a certain thickness it will separate into flakes and the edges of these flakes will curl up away from the iron of the combustion space. Carbon is not a good conductor of heat and these curled up portions soon become red hot from the heat of the power strokes. These red hot points will remain at this high temperature during the exhaust stroke, and when fresh gas is admitted to the cylinder, it will ignite before the piston reaches the top of the compression stroke. This action is called pre-ignition. It causes heavy pounding and is very destructive to the bearings as well as seriously diminishing the power output of the engine because of the force which is exerted on the crankshaft in a reverse direction.

One of the surest ways to prevent deposit of carbon in the engine is to cut down the fuel supply by turning the dash adjustment to the right while the engine is running and after it is hot. This cutting of the gasoline proportion in the mixture should be continued until there is a noticeable decrease in the speed of the engine or until there is a spitting or popping back through the carburetor. The dash adjustment should then be turned a very little to the left and allowed to remain there. Flooding of the carburetor in starting and too rich a mixture in running is sure to cause the formation of a great deal of soot in the engine.

Oil should never be poured into the engine through a filler that has become covered with dust and sand, because these impurities will be carried into the oiling system and will do serious harm. It is a mistake to use a very light bodied oil because such an oil, while operating at high temperature, will become so thin that it is of little value. It is also a mistake to use an extremely heavy oil with the expectation that it will cause an engine in poor condition to run properly. It is not possible for any oil to make up for leaky rings or loose bearings. Using an oversupply of oil for the same purpose does no good and in fact does possible harm in adding to carbon deposits.

The user of a car should not fail to drain the old oil out of the crankcase at proper intervals. After the oil has been drained away the crankcase should be washed out with kerosene before putting in a fresh supply of lubricant. Systematic regularity in doing this work and also in supplying oil and grease to all parts of the car is a sure method of securing freedom from small troubles while driving. Proper oiling is the most important thing to look after in the operation

of an automobile because a majority of troubles arise in this direction.

In selecting an oil for use its viscosity cannot be properly judged while it is at atmospheric temperature. The heat causes it to become thinner when in use in the engine. No grease that is not of the semi-fluid type should be used except in some of the grease cups. When a hard grease is used in the rear axle housing or in the wheel bearings, the revolving parts simply cut a track through the body of the grease and thereafter obtain very little lubrication.

## CHAPTER V

### POWER PLANT REPAIR

It is the intention in the following pages to give the user of a Ford car such practical information as is necessary in making all ordinary adjustments and repairs. It is not intended as a complete manual of motor car mechanics, but more as a simple explanation called for by the Ford car as distinct from all other cars.

It is very seldom necessary to remove the engine from the frame, but should it be desirable to do so, there is a right way to handle the work, and this way is described below.

First, drain the water out of the radiator and disconnect the radiator hose. Second, disconnect the radiator stay rod which holds it to the dash. Third, take out the two bolts which fasten the radiator to the frame and take the radiator off. Fourth, disconnect the dash at the two supporting brackets which rest on the frame. Fifth, loosen the steering post bracket which is fastened to the frame, and dash and steering gear may then be removed as one assembly, the wires having first been disconnected. Sixth, take out the bolts holding the front radius rods in the socket underneath the engine crankcase. Seventh, remove the four bolts at the universal joint. Eighth, remove the pans on either side of cylinder casting, turn off the gasoline and disconnect the feed pipe from the carburetor. Ninth, disconnect the ex-



haust manifold from the exhaust pipe by unscrewing the large brass packing nut. Tenth, take out the two cap screws which hold the crankcase to the front end of the frame. Eleventh, remove the bolts which hold the crankcase arms to the frame at each side. Then pass a rope through the opening between the two middle cylinders and tie in a loose knot. Through the rope pass a 2x4, or a stout iron pipe about ten feet long, and let a man hold each end. Let a third man take hold of the starting crank handle and the whole power plant can be lifted from the car to a work bench for adjustment.

In case it is found necessary during any of the work to remove the cylinder castings from the engine, a great deal of time and effort will be saved by using the following suggestions in replacing these parts of the engine.

Before replacing the cylinder castings on the engine, the outside of the pistons and the inside of the cylinders must be well oiled with ordinary cylinder oil. Have two of the pistons up as far as they will go and the other two down as far as they will go. Let one man lower the cylinders onto the pistons while another holds the pistons vertical and in the proper position. The cylinders must be lowered without twisting them or the pistons to one side or the other.

The person holding the pistons must press the piston rings tight into their grooves so that the cylinders can slip down over them. This can usually be done with the thumbs, although it may be necessary to use a band of wire or thin hoop.

All of the nuts that hold the cylinders to the crankcase should be placed on the bolts before any are made tight. All the nuts should then be turned down until

they begin to draw tight. Then go from one to the next, tightening each a little, until all are drawn evenly. Do not draw one nut tight and then go to the next.

Great care must be used to see that the flywheel is in exactly the same position on the end of the crankshaft as when the engine was taken apart. The wheel should be marked before removal to insure correct replacement. Every bolt in the flywheel mounting parts must make a perfectly tight and true fit without looseness at any point. The nuts that keep the flywheel in place must be fastened either with cotter pins, wires through the bolts, locking nuts or other means that can be depended on to prevent them from working loose.

*Piston Rings.*—Piston rings are made of cast iron and break very easily, as this metal is brittle. Great care is required in taking them out of their grooves.

The following procedure should be followed: Lift one end of the ring with a small screw driver until you can slip a thin piece of metal, such as a piece of hack saw blade, under the end of the ring, thus holding it up out of the groove. This piece of metal should point up and down the length of the piston and should be slid around under the ring until it is directly opposite the opening in the ring.

As this piece is pushed away from the opening, another similar piece is placed under the end of the ring so that the end will not again enter the groove. Leave this second piece near the opening and put a third piece under the other end of the ring and a little way from the opening. When these three pieces are in the right position the ring will be raised entirely out of the groove and will rest on the short

pieces. The ring may then be pulled up and off the piston.

To replace the rings: Open the ring just enough to slip it onto the top of the piston and then place the metal strips in the same position as for removing the ring. Slide the ring down until it is over its groove and pull the metal strips out, thus allowing the ring to fall into place. It is important to take the top off first and to put the bottom ring on first.

Before placing the rings in their grooves see that they fit properly by rolling the ring all the way around in the groove before attempting to put it on the piston. If the ring binds at any point cut it down with a fine file until it is an easy fit all around.

The openings in piston rings that are next to each other must be as far apart as possible so that escaping gas will have to travel a long distance around the outside of the piston before getting past the last ring. There are three rings and the opening in the second one should be one-third of the distance around the piston from the opening in the first one, and the opening in the third should be another third of the way around from the opening in the second.

*Compression Loss.*—Three out of the four strokes of the gasoline engine depend for their effectiveness on the fact that the combustion space and interior of the cylinder are perfectly gas-tight except for the valve openings.

These strokes are the inlet, the compression and the power. The inlet stroke would not be effective were it possible to draw gas or air from any other source than the carburetor. The gas could not be compressed to the proper degree if it could escape through any openings whatever. Much of the effort

of the power stroke would be wasted if the expanding gas could escape in place of pushing on the piston.

As the word compression is used in automobile work it really means gas tightness. If there are no appreciable leaks from the combustion space the engine is said to have good compression. If the gas can find any way out of the cylinder other than through the valve openings with the valves open it is said to have poor compression.

Considered in this way, compression is one of the most important things in automobile work, and this word is naturally in constant use among those engaged in repairing.

It may be possible for the gas to find any one of several chances to escape through openings or leaks around the valves and valve parts. The most common point of leakage is between the valve face and valve seat. The face and seat of poppet valves are tapered and ground to an accurate fit on each other, so that, when the valve is closed, a gas-tight fit is the result. The valve head raises from the seat and goes back to it many thousands of times an hour while the engine is running and the flow of burning exhaust gas over the face and seat finally pits the metal until it can no longer make a good fit. Particles of dirt or carbon often lodge between the valve face and seat and cause the valve to remain partly open so that the gas can escape. These troubles call for valve grinding, which is described later.

The valve stem passes through an opening called the valve stem guide. This guide serves to keep the valve in the proper position for correct seating. If the stem becomes warped or bent it will bind and prevent the face from coming down onto the seat with

a gas-tight fit. The stem may have a ridge or shoulder worn on it, and this shoulder will catch on the upper edge of the guide opening and prevent proper seating.

The valves are held onto their seats by means of a strong coiled spring. Should this spring break or become weak, the face will no longer be pulled onto the seat tight enough to make a proper fit.

*Carbon Removal.*—Once the deposit of carbon has become burned on the piston head and parts of the combustion chamber it is quite difficult to remove. It is therefore advisable to take all precautions against such a formation taking place in the engine. Care should be taken to see that the oil level is not raised to a point that causes excessive smoking when the engine is operated at moderately high speeds. It has already been recommended to place in each of the engine cylinders about one-half cup of kerosene each week. This is done by removing a spark plug and pouring the kerosene through the opening while the engine is hot.

Once the carbon deposit has formed in sufficient quantity to give trouble from pre-ignition it will be necessary to remove it by taking the cylinder heads off and using a scraper on the various parts until the carbon has been separated from the iron at all points. This work should be done as follows:

First, drain the water by opening the pet-cock at the bottom of the radiator; then disconnect the wires at the top of the engine and also disconnect the radiator connection attached to the engine. Remove the fifteen bolts which hold the cylinder head in place. Take off the cylinder head and, with a putty knife or screwdriver, scrape from the cylinder and piston

heads the carbonized matter, being careful to prevent specks of carbon from getting into the cylinders or into the bolt holes. In replacing the cylinder head gasket, turn the crank so that number one and number four pistons are at the top center; place the gasket in position over the pistons and then put the cylinder head in place. Be sure and draw the cylinder head bolts down evenly by giving each bolt a few turns at a time. Do not tighten those on one end of the engine before drawing them up at the other.

A method of carbon removal that is easier of application than the one just mentioned, and which gives equally good results when properly done, is that known as the oxygen process. This method requires that the gasoline supply be shut off and the engine run until all fuel is exhausted, after which the piston of the cylinder to be treated is brought to its upper dead center and allowed to remain there. A jet of pure oxygen under slight pressure is then introduced into the combustion space through a flexible nozzle and a flame is applied at the nozzle opening. The carbon will take fire in the presence of the oxygen and will burn with great rapidity and a large volume of sparks. When burning does not continue, even with the supply of oxygen present, the carbon has been removed.

*Valve Timing.*—We have seen that the inlet valve must be open during the inlet stroke and that the exhaust valve must be open during the exhaust stroke. Placing the timing gears in mesh with their teeth together so that these valves will open and close at just the right time is known as valve timing.

When the mixture of gasoline vapor and air is compressed and fired by the spark it makes a very

high pressure. This pressure drives the piston down in the cylinder until the piston moves as far as the crankshaft and connecting rod will let it go. The piston is then at the bottom of the stroke and must come back.

*Exhaust Valve Timing.*—If the exhaust valve did not open until the piston was at the bottom of the stroke the opening would take place while there was a great deal of pressure in the cylinder, and inasmuch as the piston must start back toward the cylinder head immediately after bottom center, the piston would be pushed back against this pressure. A large amount of power would be required to force the burned gas out of the cylinder while the gas was under so much pressure, and this useless waste would prevent the engine from delivering as much power as it should. The work that the piston would have to do in pushing back against the pressure left in the cylinder would use up some of the energy stored in the flywheel, and there would not be as much power left to drive the car as there would be if the burned gas could be gotten out of the cylinder before the piston starts back.

In order to get this burned gas out of the cylinder as soon as possible, so that the piston will not have so much work on the return stroke, the exhaust valve is made to open while the piston is coming down on the power stroke. That is, the exhaust valve will open before the piston gets to the lower end of the power stroke and will start to let the burned gas out so that the pressure will be greatly reduced by the time the piston does start back on the exhaust stroke.

The exhaust valve then stays open during the balance of the power stroke, all through the up stroke, and for a short time after top center. One of the

most important things to remember in valve timing is that the inlet valve must not open until after the exhaust valve is fully closed. The rule to follow in setting the opening of an inlet valve is to have it open just as soon after the exhaust valve closes as is possible without having both valves open at the same time.

*Inlet Valve Timing.*—As the piston travels down on the inlet stroke the inlet valve will be open and the mixture will enter the cylinder through the inlet valve opening. While the engine is running, the piston moves down in the cylinder at a high rate of speed and the result is that the cylinder is not completely filled with mixture because the mixture that comes in is stretched out in the same way that the air is stretched in a pump when the handle is pulled. After the plunger of a pump is at the end of its stroke air will still come into the tube of the pump. In the same way the mixture will still come into the cylinder of the gasoline engine after the piston has moved clear to the bottom of the inlet stroke. The mixture that still keeps coming in fills up the cylinder so that the gas is no longer stretched out.

In order to get a cylinder full of mixture the gas is allowed to flow in after the piston has reached the bottom center. It would not be practicable to stop the engine every time it comes to this point while the extra mixture comes into the cylinder, so the inlet valve is allowed to stay open after bottom center. The relation of the strokes to each other is shown in Figure 43.

In the Ford engine only one camshaft is used. This one camshaft carries all the cams. When the engine was built the cams were placed in their proper posi-



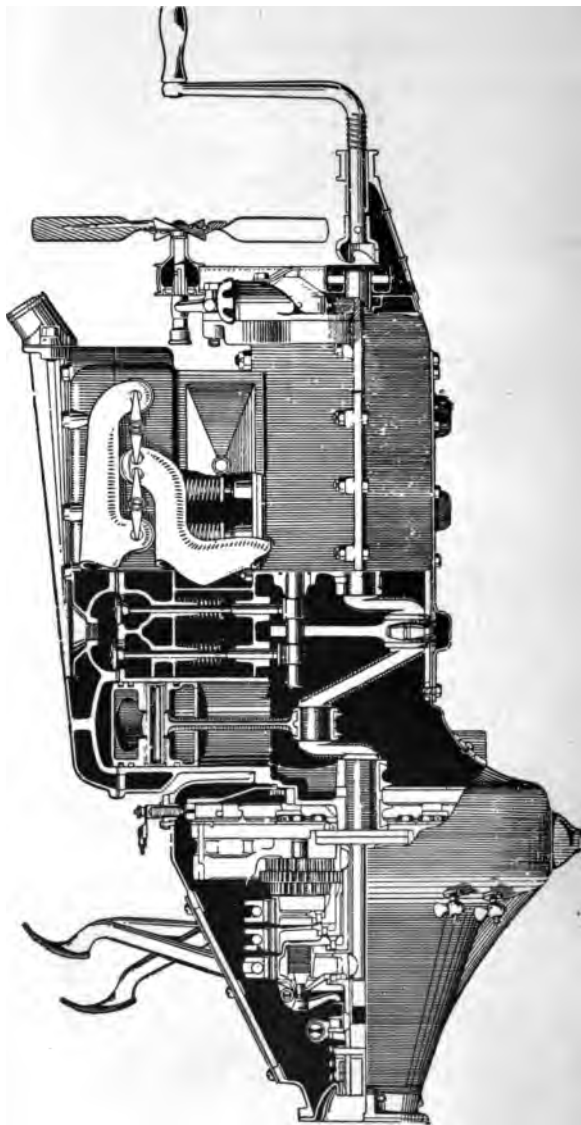

**Figure 43.—The Ford Engine and Transmission.**

tions at the factory so that they open and close the valves at the proper time according to the speed and size of the engine. It is not possible to change the location or position of the cams on the shaft, so it is clear that if one cam is placed in position so that it opens and closes its valve at the proper time all the other cams will be set in the right place by the same operation. The valve position and order of firing

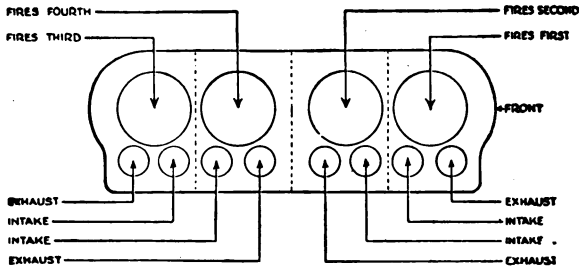

Figure 44.—Firing Order of the Ford Engine.

which determine the cam settings are shown in Figure 44.

As long as the shape and size of the cams decide how long the valves will stay open, and the placing of the cams on the shaft decides how the inlet valves work relative to the exhaust valves, there is no use in attempting to set more than one position of one kind of valve. All the other openings and closings will then take care of themselves.

As already mentioned, the valve push rods may have been fitted with adjusting screws in the upper end. Some cars are without adjustment, in which case it is necessary to fit adjustments in the repair

shop or else get new push rods, new valves, or both, when wear takes place.

Some engines have no adjustment on the push rod, but do have one on the end of the valve stem. This is usually taken care of by cutting a screw thread on the lower end of the stem and screwing a nut and locking device onto the end of the valve stem. This serves the same purpose as the push rod adjustment.

There must always be a small space between the lower end of the valve stem and the upper end of the push rod. This space is left so that when the valve heats up and the stem expands the valve will still be able to close. If the end of the stem touched the end of the push rod with the engine cold, the valve would be held off its seat when the stem heated and got longer. This space should be equal to the thickness of a thin calling or business card. The less space at this point the quieter the engine will run.

The following rules should be noted. The truth of these statements will be seen if you consider the subject carefully. Lengthening the push rod adjustment by bringing the end of the valve stem and the push rod closer together opens the valve sooner and closes it later, so that the valve is held open longer.

Shortening the push rod adjustment by moving the end of the valve stem and the push rod farther apart opens the valve later and closes it earlier so that the valve is not held open so long.

When the car leaves the factory the valves are accurately timed. The necessity for retiming seldom occurs unless the camshaft or timing gears should be removed in overhauling the engine. If the camshaft is removed for any reason care must be taken to replace it so that the tooth of the small timing gear

which is indicated by a zero mark on the gear will mesh between the two teeth of the large timing gear at the zero mark.

In fitting the large timing gear to the camshaft it is important to see that the first cam points in a direction opposite to the zero mark as shown in Figure 45. The timing gears being properly set, the exhaust valve

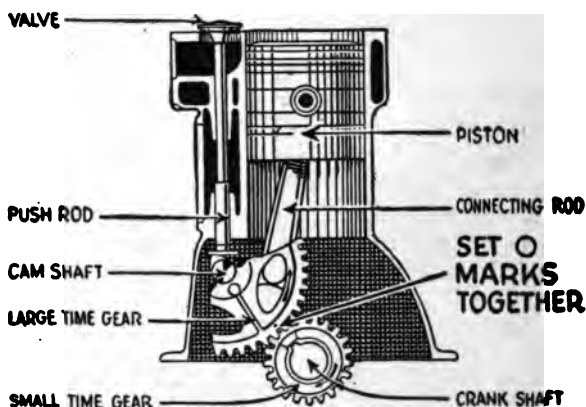

Figure 45.—Setting the Timing Gears.

on number one cylinder is open and the intake valve closed.

The operation of the opening and closing of the valves is as follows: The exhaust valve opens when the piston reaches within  $\frac{5}{16}$  of an inch of bottom center, the distance from the top of the piston head to the top of the cylinder casting measuring  $3\frac{3}{8}$  inches.

The exhaust valve will close on top center, the piston being  $\frac{5}{16}$  of an inch above the edge of the cylinder casting. The intake valve opens  $\frac{1}{16}$  of an inch after

top center and closes  $\frac{9}{16}$  of an inch after bottom center, the distance from the top of the piston to the top of the cylinder casting measuring  $3\frac{1}{8}$  inches.

The clearance between the push rod and valve stem, as shown in Figure 46, should never be greater than  $\frac{1}{32}$  of an inch nor less than  $\frac{1}{64}$  of an inch. The correct clearance is naturally half way between these two measurements. The gap should be measured when the push rod is on the heel of the cam.

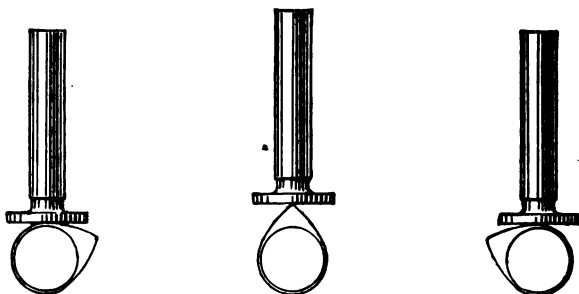

Figure 46.—Operation of Cam and Valve Push Rod.

*Valve Grinding.*—The valves seldom get out of order, but they do get dirty as a result of carbon collecting on the valve seats. These carbon deposits, by preventing proper closing of the valves, permit the gases under compression to escape, resulting in loss of power and uneven running of the engine. If, when cranking the engine slowly, there is a lack of resistance in one or more cylinders, it is probable that the valves need regrinding. As the power of the engine depends largely upon the proper seating of the valves it is necessary that they be ground occasionally.

To remove the valves for grinding, first drain the

radiator; second, remove the cylinder head; third, remove the two valve covers on the right hand side of the engine; fourth, raise the valve spring with a spring lift tool, as shown in Figure 47, and pull out the little pin under the washer. The valve may then be lifted out and is ready for grinding.

For this work use a good grinding paste of ground glass, fine emery or carborundum and oil, any of

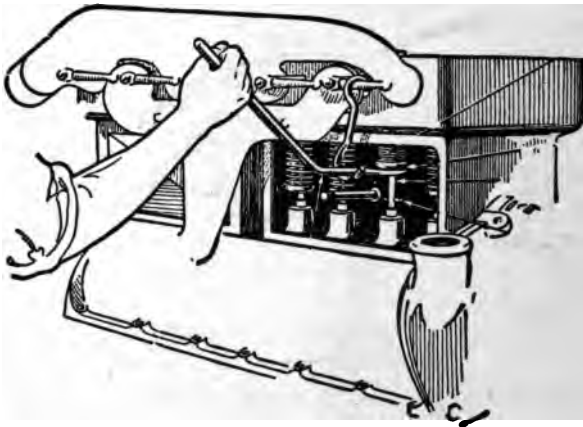

Figure 47.—Using the Valve Stem Lifter.

which are procurable from auto supply houses. A convenient way is to put a small amount in a suitable dish, adding a spoonful or two of kerosene and a few drops of lubricating oil to make a thin paste.

Place the mixture sparingly on the bevel face of the valve. Put the valve in position on the valve seat and rotate it back and forth (about a quarter turn) with a tool, as shown in Figure 48. Then lift the valve slightly from the seat, change its position

and continue the rotation. Repeat this operation until the bearing surface is smooth and bright after being washed off with gasoline or kerosene.

The valve should not be turned through a complete revolution, as this is apt to cause scratches running

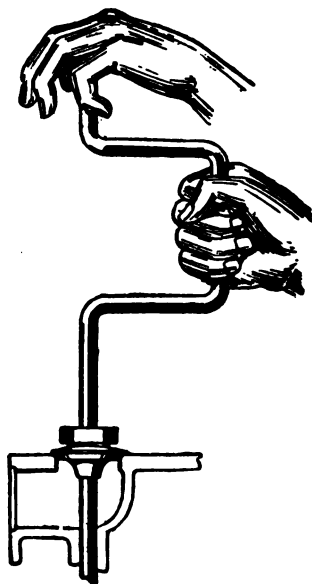

Figure 48.—Using the Valve Grinding Tool.

around the entire circumference of the valve and seat. When grinding is completed the valve should be removed from the cylinder, thoroughly washed with kerosene, and the valve seat wiped out thoroughly. Extreme care should be taken that no abrasive substance gets into the cylinders or valve guides. This

can be avoided if the grinding paste is applied sparingly to the bevel face of the valve.

If the valve seat is badly worn or seamed, it is best to have it resealed with a valve seating tool. This operation requires considerable skill, and perhaps had better be done by an expert mechanic. Care should be exercised against making too deep a cut, necessitating the retiming of the valve.

When the valves, or push rods, become worn, so as to leave too much play between them, and thus reduce the lift of the valves and power of the engine, it is best to replace the push rods with new ones. If the clearance is too great, the valve will open late and close early, resulting in uneven running of the engine. If the clearance is less than  $1/64$  of an inch there is danger of the valve remaining partly open all the time. If replacing the push rod does not give the proper clearance, the valve also should be replaced. Drawing out the valve stem is not recommended as the operation requires experience, and the price of the new part does not warrant the time and expense necessary to do the work properly.

When the valves fail to seat properly there is a possibility that the springs may be weak or broken. A weak inlet spring would probably not affect the running of the engine, but weakness in the exhaust valve spring causes a very uneven action, the cause of which is difficult to locate. The symptoms are a lag in the engine, due to the exhaust valve not closing instantaneously, and as a result a certain percentage of the charge under compression escapes, greatly diminishing the force of the explosion. Weakness in a valve spring can usually be detected by the following method: Remove the plate which encloses the valve stems at



the side of the cylinder and insert a screwdriver between the coils of the spring while the engine is running. If the extra tension thus produced causes the engine to pick up speed, the spring is obviously weak and should be replaced with a new one.

#### BEARINGS

A plain bearing is made from metal which has certain qualities that prevent excessive friction as the shaft turns inside of the bearing. The bearing proper is in the form of a hollow tube that surrounds the part of the shaft to be supported, and is itself held in some form of holder or housing supported by the solid framework of the engine.

Plain bearings may be made in one piece, or they may be divided into two parts by cutting lengthwise of the tube, leaving an upper and lower half. The design of the bearing, whether in one or two pieces, depends on whether or not it can be put on over the end of the shaft or must be placed at some point along the shaft without sliding it into position.

Various kinds of metal may be used for plain bearings, the commonest being that known as white metal. White metal bearings cannot be successfully made in the ordinary shop, but are secured from bearing makers. Babbitt bearings are used where the speed is low, or the load comparatively light. Babbitt bearings may be poured or made by melting the babbitt metal and casting it into a mould made around the shaft to be supported. Brass and bronze bearings are used for heavy loads, and are made by boring the excess metal from solid or hollow bars of bearing metal.

Plain bearings of any material require ample and

continuous supplies of oil while in use. Inasmuch as the bearing makes a close fit around its shaft it is not possible to introduce enough oil through the ends of the bearing to properly lubricate the central part. To secure oil at these central parts small holes are drilled through the bearing and holder which lead right in to the shaft. Oil is sent into these holes by various means so that a supply is always present under running conditions.

To allow this oil to spread over the inside surface of the bearing, oil grooves are cut into the inner surface of the bearing metal so that they lead from the oil hole at the center to various parts of the surface, and allow the oil a free passage to the points of friction.

While all plain bearings require more lubrication than either ball or roller types, some materials require more than others even in plain bearings. Babbitt requires less than any of the other metals, having greater antifriction properties in itself. White metal, white brass and white bronze also require comparatively little oil. Brass and bronze bearings require more lubrication than any of the foregoing materials, and this is partly secured by having a greater number of oil grooves leading away from the center hole.

Solid bearings are made of such an outside diameter that they may be forced or pressed into their holder. The holder in this case is a part of the engine, the upper end of the connecting rod, or some other one of the stationary parts of the engine. After being pressed into position the bearing is held from endwise movement, and from turning around in the holder by set screws which pass through the holder and into the metal of the bearing, by retaining nuts, by small pro-

jecting lugs on the bearing, or by some other easily recognized method of holding.

Care must be used to see that the oil hole in the bearing itself, and the oil hole through the holding part are in line so that the lubricant has a free passage to the surface of the shaft.

A majority of plain bearings are split into halves and are carried in holders which are also made in halves. One-half of the holder is stationary, or is fastened to some principal part of the engine, the other half is removable and is called the bearing cap. The cap is held on the stationary part by bolts on each side of the cap.

*Bearing Adjustment.*—It is necessary that a bearing make an almost perfect fit around its shaft. The shaft itself must be perfectly round and of the same diameter at all points along the length of the bearing. The bearing should fit closely enough so that there is no noticeable play when moved by hand and still be free enough to allow the shaft to turn without undue resistance from the bearing surface. It will be realized that this requires very careful and accurate fitting.

When a solid plain bearing becomes loose on the shaft it cannot be refitted satisfactorily and should be replaced with a new one. Several makeshifts may be used when it is impossible or undesirable to replace the bearing. The best of these methods consists of turning out the inside of the bearing on a lathe until it clears the shaft by about  $\frac{1}{8}$  of an inch all around. This space is then poured full of babbitt which forms a new lining.

Another method is as follows: Secure a piece of thin brass, called shim stock, which is of sufficient

thickness to fill the space between the bearing surface and the shaft. This shim stock may be secured in thicknesses varying by  $\frac{1}{1000}$  of an inch. With a hack-saw blade cut a groove lengthwise of the bearing and in the inner surface so that it forms a slot from end to end of the bearing. Place the shim stock around the shaft so that the ends of the brass may be bent to catch in the slot cut by the hack-saw blade. This will prevent the thin lining from turning with the shaft.

Still another way consists of cutting completely through one side of the bearing and lengthwise of it so that a sufficient quantity of metal is removed to allow the parts of the bearing to be squeezed together just as any ring may be made smaller when part of it has been removed. It will then be necessary to fit wedges between the bearing and holder to keep the bearing at the desired size or else to fit clamps which may be tightened as desired. This method has been used for taking up the play in the upper connecting rod which fits over the wrist pin.

Split bearings are usually provided with small pieces of rather thin metal which hold the halves of the bearing apart. These pieces are called shims. When excessive looseness develops in the bearing one or more of these pieces may be removed from between the halves of the bearing and with the halves closer together a large part of the play is removed.

The bearing cap should be removed and the thinnest shim removed from each side. The cap is then replaced and the shaft turned in the bearing. If too tight to turn freely, one of the shims which was removed, or another shim thinner than those removed should be replaced and another trial made. If, with one shim removed from each side, the play is still too

great the cap is again removed and another pair of shims removed. Shims should be removed or replaced, always keeping approximately the same thickness on each side of the cap, until the play has been removed without preventing free turning.

It is important that the shims extend from the surface of the shaft clear to the outer edges of the cap and holder and that they entirely cover the edges of the bearing in the cap and also the cap itself. The shim must entirely fill the space between the halves of the bearing of the cap and of the stationary part of the holder.

A laminated shim is formed of a number of very thin shims of the same thickness and size laid one on top of another and the whole pile fastened together by solder between the layers. To reduce the thickness of a laminated shim it is only necessary to catch the edge of one layer with the blade of a knife and peel it off.

After a bearing is fitted it should be tested as follows: Remove the cap and clean the inner surface of the bearing and the surface of the shaft with gasoline or kerosene. Then secure a tube of Prussian blue, which is a kind of ink, and with the tip of the finger smear the blue over the surface of the shaft only. As much as can be picked up on the tip of a small knife blade is enough for one application. With the blue evenly distributed, replace the bearing and tighten the bolts and nuts.

Turn the shaft or bearing once or twice around and again remove the bearing. Wherever the bearing touched the shaft will be indicated by a blue coating on the bearing surface. With a bearing adjusted by removal of shims it will be found that the bottom and

top of the bearing will touch the shaft but that the parts of the bearing nearer the joint between the two halves do not touch. This fault cannot be overcome except by the process of scraping to a true fit.

Should the connecting rod bearing become worn or burned out through lack of oil, a knocking in the engine will result, in which case the entire connecting rod may be replaced. To make this replacement, first drain the oil from the crankcase; second, take off the cylinder head; third, remove the detachable plate on the bottom of the crankcase; fourth, disconnect the connecting rod from the crankshaft, and fifth, take the piston and rod out through the top of the cylinder.

Connecting rod bearings may be adjusted without taking out the engine by the following method: First, drain off the oil; second, remove the plate on the bottom of the crankcase which exposes the connecting rods; third, take off the first connecting rod cap and draw-file the ends a very little at a time; fourth, replace the cap, being careful to see that the punch marks correspond and tighten the bolts until the bearing fits the shaft snugly; fifth, test the tightness of the bearing by cranking the engine; sixth, loosen the bearing and proceed to fit the other bearings in the same manner; seventh, after each bearing has been properly fitted and tested tighten the cap bolts and the work is finished.

Remember that there is a possibility of getting the bearings too tight, and under such conditions the babbitt is apt to cut out quickly unless precaution is taken to run the engine slowly at the start. It is a good plan after adjusting the bearings to jack up the rear wheels and let the engine run slowly for about

two hours, keeping it well supplied with water and oil.

Worn connecting rods may now be returned, pre-paid, to the nearest Ford agent or branch house for exchange at a price of seventy-five cents each to cover the cost of rebabbiting. It is not advisable for an owner or repair shop to attempt the rebabbiting of connecting rods or main bearings, for without a special jig in which to form the bearings satisfactory results will probably not be obtained. The constant tapping of a loose connecting rod on the crankshaft will eventually produce crystallization of the steel, resulting in a broken crankshaft and possible damage to other parts of the engine.

Should the stationary bearings in which the crankshaft revolves become worn it will become evidenced by a pounding in the engine. In replacing or adjusting these bearings proceed as follows:

First, with the engine out of the car, remove the crankcase, the transmission cover, the cylinder head, the pistons, the connecting rods, the transmission and the magneto coils. Take off the three babbitted caps and clean the bearing surfaces with gasoline. Apply Prussian blue or red lead to the crankshaft bearing surfaces, which will enable you to determine whether a perfect bearing surface is obtained in the same way as described for fitting the connecting rods.

Second, place the rear cap in position and tighten it up as much as possible without stripping the bolt threads. When the bearing has been properly fitted the crankshaft will permit moving it with one hand. If the crankshaft cannot be turned with one hand the contact between the bearing surfaces is evidently too close, and the cap requires shimming up, one or two

brass liners usually being sufficient. In case the crankshaft moves too easily with one hand, the shims should be removed and the steel surface of the cap filed off, permitting it to set closer around the bearing.

After removing the cap, observe whether the blue or red spottings indicate a full bearing for the length of the cap. If spottings do not show a true bearing, the babbitt should be scraped and the cap refitted until the proper results are obtained.

Fourth, lay the rear cap aside and proceed to adjust the center bearing in the same manner. Repeat the operation with the front bearing while the other two bearings are laid aside.

Fifth, when the proper adjustment of each bearing has been obtained, clean the babbitt surface carefully and place a little lubricating oil on the bearings, also on the crankshaft; then draw the caps up as closely as possible with the necessary shims in place. Do not be afraid of getting the cap bolts too tight, as the shim under the cap and the oil between the bearing surfaces will prevent the metal being drawn into too close contact. If oil is not put on the bearing surface, the babbitt is apt to cut out when the engine is started and before the oil in the crankcase can get into the bearing. In replacing the crankcase and transmission cover on the engine it is advisable to use a new set of felt gaskets to prevent oil leaks.

*Scraping Bearings.*—This is done with a tool called a bearing scraper which is made with a blade having two or three sharp corners or edges and held in a wood handle. The blade may be three-cornered or flat.

The bearing, with the Prussian blue or red lead still on the surface, is held in a vise by clamping the jaws firmly but not tight enough to bend the bearing. The



jaws should clamp the ends of the bearing and not the sides. The handle of the scraper is grasped with the fingers of the right hand and the blade laid on the surface of the bearing so that two edges touch the bearing surface. By pressing lightly with the fingers of the left hand on top of the blade where it rests in the bearing, while the blade is moved by the right hand, a very little metal may be removed from the surface at the points where the blue shows. After the blue has been removed the bearing is replaced on the shaft, the shaft having been given another coat of the stain, and with the bolts tightened, the shaft or bearing is again turned.

The bearing is again removed and the blue carefully scraped away, this process being repeated until at least two-thirds of the entire surface of the bearing is covered with the blue when it is removed from the shaft. This must be done with both halves of the bearing. After the fitting is completed the remainder of the blue is removed from the shaft and bearing with gasoline. The surfaces of both bearing and shaft are then covered with cylinder oil and the bearing is replaced.

The surface of the shaft where it runs through the bearing must be perfectly smooth and free from ridges and rings. If it is not in this condition, the shaft will have to be turned smooth in a lathe or else it must be lapped. A bearing should never be replaced on its shaft until all rubbing surfaces have been wiped clean and covered with lubricating oil.

A connecting rod bearing is properly tightened when the connecting rod and piston will remain in an upright position when placed there but will fall and

turn the bearing on the shaft when once started by pushing the piston to one side or the other.

A crankshaft bearing is properly tightened when the shaft shows no play when pried with a bar but may still be whirled part of a turn by hand.

It is very essential that all bolts and nuts be securely tightened and locked in place with a wire or cotter pin passing through the nut and bolt. Lock washers should not be depended upon at any point inside of the engine.

#### ENGINE AUXILIARIES

*Ignition Adjustments.*—The present style of coil unit is properly adjusted when it leaves the factory and this adjustment should not be disturbed unless to install new points or to reduce the gap between the points which may have increased from wear. When adjustments are necessary they should, whenever possible, be made by a service station having special equipment for testing and adjusting units. If the points are pitted they should be filed flat with a fine double-faced file and the adjusting thumb nut turned down so that with the spring held down the gap between the points will be a trifle less than  $\frac{1}{32}$  of an inch. Then set the lock nut so that the adjustment can not be disturbed. Do not bend or hammer on the vibrators, as this would affect the operation of the cushion spring of the vibrator bridge and reduce the efficiency of the unit.

In case it becomes necessary to remove the commutator take out the cotter pin from the spark rod and detach the rod from the commutator. Loosen the cap screw which goes through the breather pipe on the top of timing gear cover. This will release the spring

which holds the commutator case in place and this part can be readily removed. Then unscrew the lock nut; withdraw the steel roller cap and drive out the

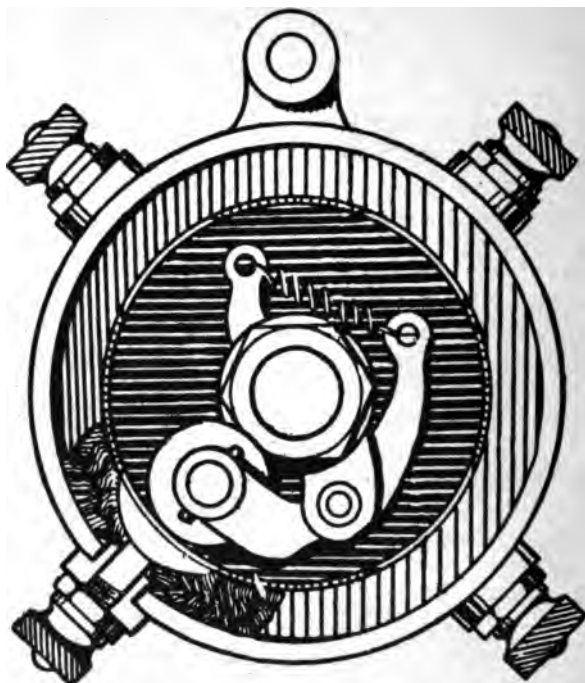

Figure 49.—Parts of the Commutator.

retaining pin. The roller can then be removed from the camshaft. These parts are shown in Figure 49.

In replacing the roller, care must be exercised to see that it is reinstalled so that the exhaust valve on the first cylinder is closed when the roller points

upward. This may be ascertained by removing the valve cover and observing the operation of number one valve.

It is necessary to take the power plant out of the car in order to remove the magneto. Then remove the crankcase and transmission cover and take out the four cap screws that hold the flywheel to the crankshaft. You will then have access to the magnets and entire magneto mechanism. In taking out these parts, or any other parts of the car, the utmost care should be taken to make sure that the parts are so marked that they may be replaced properly.

The Ford magneto is made with permanent magnets and there is very little likelihood of their losing their strength unless acted upon by some outside force such as the attachment of a storage battery to the magneto terminal which will demagnetize the magnets. If anything like this happens it is not advisable to try to recharge them, but rather install a complete set of new magnets. The new magnets will be sent from the nearest agent or branch house, and will be placed on a board in identically the same manner as they should be when installed on the flywheel, which is shown in Figure 50. Great care should be taken in assembling the magnets and lining up the magneto so that the faces of the magnets are separated from the surfaces of the coil spools just  $\frac{1}{32}$  of an inch. To take out the old magnets, simply remove the cap screw which holds each in place. The magneto is often blamed when the trouble is a weak current caused by foreign matter accumulating under the contact spring which is held in place by the binding post on top of the crankcase cover. Remove the three screws which hold the binding post in place, then remove the bind-

## CHAPTER VI

### TRANSMISSION AND RUNNING GEAR ADJUSTMENTS

The parts of the Ford car which are included in the transmission system and the running gear are provided with such liberal adjustments that it should not be necessary to make any repairs except in case of accident. The best methods of keeping these parts of the car in perfect running order and of assembling and disassembling them are described in the following paragraphs.

*Transmission and Clutch.*—In order to remove the transmission from the engine, it is first necessary to take the power plant out of the car. Then remove the crankcase and the transmission cover. Take out the four screws that hold the flywheel to the rear end of the crankshaft and the entire transmission may be easily removed from the cylinder casting.

Figure 51 shows the transmission parts in their relative positions and grouped for the different operations of assembling. The first operation is to place the brake drum on a table or bench with the hub in a vertical position. Place the slow speed plate over the hub with the gear uppermost. Then place the reverse plate over the slow speed plate so that the reverse gear surrounds the slow speed gear. Put the driven gear in position with the teeth downward so that they will come next to the slow speed gear. Take the three triple gears and mesh them with the driven gear according to the punch marks on the teeth, the reverse



## CHAPTER VI

### TRANSMISSION AND RUNNING GEAR ADJUSTMENTS

The parts of the Ford car which are included in the transmission system and the running gear are provided with such liberal adjustments that it should not be necessary to make any repairs except in case of accident. The best methods of keeping these parts of the car in perfect running order and of assembling and disassembling them are described in the following paragraphs.

*Transmission and Clutch.*—In order to remove the transmission from the engine, it is first necessary to take the power plant out of the car. Then remove the crankcase and the transmission cover. Take out the four screws that hold the flywheel to the rear end of the crankshaft and the entire transmission may be easily removed from the cylinder casting.

Figure 51 shows the transmission parts in their relative positions and grouped for the different operations of assembling. The first operation is to place the brake drum on a table or bench with the hub in a vertical position. Place the slow speed plate over the hub with the gear uppermost. Then place the reverse plate over the slow speed plate so that the reverse gear surrounds the slow speed gear. Put the driven gear in position with the teeth downward so that they will come next to the slow speed gear. Take the three triple gears and mesh them with the driven gear according to the punch marks on the teeth, the reverse



Figure 52.—Transmission and Clutch Partly Assembled

**W**



gear or smallest of the triple gear assembly being downward. After making sure that the triple gears are properly meshed, tie them in place by passing a cord around the outside of the three gears.

Place the flywheel on the table or bench with the face downward and the transmission shaft in a vertical position; then invert the group which you have assembled over the transmission shaft, setting it in position so that the triple gear pins on the flywheel will pass through the triple gears. This will bring the brake drum on top and in a position to hold the clutch plates.

The next step is to fit the clutch drum key in the transmission shaft. Press the clutch disc drum over the shaft and put the set screw in place to hold the drum. Put the distance plate over the clutch drum, add a small disc, then a large one, alternating with large and small discs until the entire set of discs is in position and ending up with a large disc on top. If a small disc is on top it is liable to fall over the clutch drum in changing the speed from high to low and as a result the driver would be unable to change back into high speed.

Next put the clutch push ring over the clutch drum, and on top of the discs, with the three pins projecting upward. Note that the remaining parts are placed as they will be assembled. Next bolt the driving plate in position so that the adjusting screws of the clutch fingers will bear against the clutch push ring pins. Before proceeding farther it would be a good plan to test the transmission by moving the plates with the hands. If the transmission is properly assembled the flywheel will revolve freely while holding any of the drums stationary.



Figure 52.—Transmission and Clutch Partly Assembled

**WBI**

The clutch parts may be assembled on the driving plate hub as follows: Slip the clutch shaft over the hub so that the small end rests on the ends of the clutch fingers. Next put on the clutch spring, placing the clutch supports inside so that the flange will rest on the upper coil of the spring. Next place the clutch spring thrust ring with the notched end down and press it into place, inserting the pin in the driving plate hub through the holes in the side of the spring support.

The easiest method of compressing the spring sufficiently to insert the pin is to loosen the tension of the clutch fingers by means of the adjusting screws. When again tightening up the clutch the spring should be compressed to occupy a space of two or two and one-sixteenth inches to insure against the clutch slipping. Care should be exercised to see that the screws in the fingers are adjusted so the spring is compressed evenly all around. The transmission and clutch when partly assembled are shown in Figure 52.

Do not place any small tools or objects over or in the transmission case without a good wire or cord attached to them. It is almost impossible to recover them without taking off the transmission cover.

The method of making transmission adjustments may be understood from Figure 53. To adjust the clutch remove the plate on the transmission cover under the floor boards at the driver's feet. Take out the cotter pin on the first clutch finger and give the screw from one-half to one complete turn to the right with a screwdriver. Do the same to the other finger set screws. But be sure to give each screw the same number of turns or parts of a turn and do not forget to replace the cotter pin. After a considerable period

of service the wear in the clutch may be taken up by installing an additional pair of clutch discs rather than by turning the adjusting screws in too far.

The slow speed band may be tightened by loosening the lock nut on the right side of the transmission

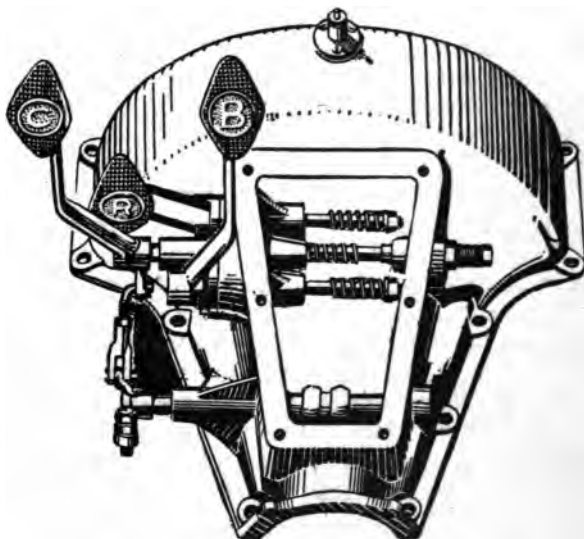

Figure 53.—Transmission Band Adjustments.

cover and turning the adjusting screw to the right. To tighten the brake band and reverse band remove the transmission case cover plate and turn the adjusting nuts on the shafts to the right. See that the bands do not drag on the drums when disengaged as they would exert a braking effect and tend to overheat the engine. The foot brake should, however, be adjusted so that a sudden pressure will stop the car immedi-

ately or slide the rear wheels in case of emergency. The bands, when worn to such an extent that they will not take hold properly, should be relined so that they will engage smoothly without causing a jerky movement of the car.

To remove the bands, take off the plate on top of the transmission cover. Turn the reverse adjustment nut and the brake adjustment nut to the extreme ends of the pedal shafts, then remove the slow speed adjusting screw. Remove the bolts holding the transmission cover to the crankcase and lift off the cover assembly. Slip the band nearest the flywheel over the first of the triple gears, then turn the band around so that the opening is downward. The band can now be removed by lifting it upward. The operation is more easily accomplished if the three sets of triple gears are so placed that one set is about ten degrees to the right of the center and at the top. Each band may be removed by a similar operation. It is necessary to push each band forward onto the triple gears as only at this point is there sufficient clearance in the case to allow the ears of the transmission bands to be turned downward. By reversing this operation the bands may be installed. After being placed in their upright position on the drums, pass a cord around the ears of the three bands, holding them in the center so that when putting the transmission cover in place no trouble will be experienced in getting the pedal shafts to rest in the notches in the band ears. The clutch release ring must be placed in the rear groove of the clutch shaft. With the cover in place remove the cord which held the bands in place while the cover was being installed.

*Rear Axle and Brakes.*—To remove the rear axle

jack the wheels free of the floor and take them off the axle. Take out the four bolts that connect the universal joint cap to the rear end of the transmission case and transmission cover. Disconnect the back radius rods, remove the nuts which hold the spring seats onto the rear axle housing flanges, raise the rear end of the frame and the axle may be easily withdrawn.

In order to disconnect the universal joint from the drive shaft, first remove the two plugs from the top and bottom of the ball casting, then turn the rear wheel and drive shaft until the universal pin is opposite the hole in the casting. Now drive the pin out and the joint may be pulled or forced away from the shaft and out of the housing.

To disassemble the rear axle, proceed as follows: With the universal joints disconnected remove the nuts in the front end of the radius rods and the nuts on the studs holding the drive shaft tube to the rear axle housing. Remove the bolts which hold the two halves of the differential housing together. If it is necessary to disassemble the differential a very slight mechanical knowledge will permit one to immediately discern how to do it once it is exposed to view. Care must be exercised to get every pin, bolt and key back in its correct position when reassembling.

To remove the small pinion from the rear end of the drive shaft it is only necessary to remove the castellated nut and drive the pinion off. The end of the drive shaft to which the pinion is attached is tapered to fit the tapered hole in the pinion. The pinion is pressed onto the shaft and is secured by the castellated nut and a cotter pin.

The differential gears are attached to the inner

ends of the rear axle shafts. When turning a corner they work upon the spider gears so that the shafts revolve independently of each other, but when the car is moving in a straight line the spider gears, the compensating gears and the axle shafts move as a unit. An examination of the rear axle shafts will show that the gears are keyed on and held in position by a ring which is in two halves and fits into a groove in the rear axle shaft. To remove the compensating gears force them down on the shaft; that is, away from the end to which they are secured, drive out the two halves of the ring from the grooves in the shaft with a screwdriver or chisel and then force the gears off the end of the shafts.

To remove the rear axle shaft, disconnect the rear axle, then unbolt the drive shaft assembly where it joins the rear axle housing at the differential. Disconnect the two radius rods at the outer ends of the housing. Take out the bolts which hold the two halves of the rear axle housing together at the center. Take the inner differential casing apart and draw the axle shaft through the housing at the center.

After replacing the axle shaft be sure that the rear wheels are firmly wedged on at the outer end of the axle shaft and that the key is in its proper position. When a new car has been driven thirty days or so, the hub cap should be removed and the lock nut tightened to overcome any play that may have developed. It is extremely important that the rear wheels be kept tight, otherwise the constant rocking back and forth against the keyway may in time cause serious trouble.

If either the rear axle or wheel is sprung by skidding against a curb or by any other accident, it is

false economy to drive the car because tires, gears and all other parts will suffer. If the axle is bent, it can with proper facilities be straightened, but it is best to replace it.

The adjustment of the foot brake has already been explained under the care of the transmission bands. The rear wheel brakes may be adjusted by removing the pin and disconnecting the end of the pull rod from the small lever, then screwing the rod end farther onto the rod itself.

If the facing of the rear brake shoes is found to be filled with grease this accumulation may be removed by directing the flame from an ordinary blow torch against the grease covered parts until all of the oil has been burned away.

*Front Axle and Steering Gear.*—To remove the front axle from the car-jack up the front of the car so that the wheels can be removed, disconnect the steering gear ball arm from the spindle connecting rod, disconnect the radius rod at the ball joint and remove two cotter-pinned bolts from the spring shackle on each side, thus detaching the front spring.

To disconnect the radius rod from the axle, remove the cotter-pinned nuts. To remove the radius rod entirely take the two bolts out of the ball joint and remove the lower half of the cap.

Should the axle or spindle become bent, extreme care must be used to straighten the parts accurately. Do not heat the forgings, as this will draw the temper of the steel, but straighten them cold. If convenient it would be better to return such parts to the Ford factory where they may be properly straightened in jigs designed for that purpose. It is very essential that the wheels line up properly.



Should the steering gear become so loose that a slight movement of the hand wheel does not produce immediate results at the road wheels, it may be tightened in the following manner: Disconnect the two halves of the ball and socket which surrounds the ball arm at the lower end of the steering post and file off the surfaces until they fit snugly around the ball. If the ball is badly worn it is best to replace it with a new one. Also tighten the ball caps at the other end of the steering gear connecting rod in the same manner. If the bolts in the steering arms appear to be loose the brass bushings should be replaced with new ones. Excessive play in the front axle may be detected by grasping one of the front wheels by the spokes and jerking it back and forth. After the car has been in service two or three years excessive play in the steering gear may make necessary the renewal of the small pinions, as well as the brass internal gear which is just underneath the steering hand wheel.

It is also advisable to inspect the front spring hangers occasionally to determine whether or not new bushings are necessary to overcome the results of any excessive vibration.

*Springs.*—It is very necessary that the center of the spring be kept tightly clipped to the frame because a loose spring will usually result in broken leaves. Near the outer ends of the springs are small bands which clasp four or five leaves and hold them tightly together. These are called rebound clips and are for the purpose of preventing the leaves from moving away from each other when the car body is thrown upward by the recoil of springs after they have been compressed. If these rebound clips were

not used the upward motion of the car body would have to be checked by the long main leaf alone, but with the clips in place this load is put upon all of the leaves which are thus fastened together and the strain is distributed.

Much may be done toward preventing spring breakage by keeping all of the clips tight and by keeping the springs well lubricated so that there is no unnecessary friction. This lubricating may best be done by spreading the ends of the leaves apart, either with a screwdriver or with a special tool made for the purpose. While the leaves are separated place a small amount of graphite and lubricating oil mixture between them.

*Wheels and Bearings.*—To remove a front wheel take off the hub cap, remove the cotter pin and unscrew the castlelatted nut and spindle washer. The adjustable bearing cone can then be taken out and the wheel removed. Care should be taken to see that the cones and lock nuts are replaced on the same spindle from which they were removed, otherwise there is a liability of stripping the threads which are left handed on the left spindle and right handed on the opposite side. The back wheels should not be removed unless absolutely necessary, but if this work is called for, remove the hub cap and nut, then with a wheel puller remove the wheel from the tapered shaft to which it is locked with a key. In replacing the rear wheels be sure that the nut on the axle shaft is as tight as possible, and that the cotter pin is in place. The hub caps of the rear wheels should be removed occasionally, and the lock nuts which hold the hub in place tightened up. If these nuts are allowed to work loose, the resulting play on the hub key may eventually twist off the axle shaft.

It will be observed that the front wheels are dished,

that is, the spokes are given a slight outward flare to better enable them to meet side stresses. The spokes of the rear wheels are straight. The front wheels are also placed at an angle with the road so that the distance between the tops of the wheel is about three inches greater than between their bottoms. This is to give perfect steering qualities and to save wear on the tires when turning corners. The front wheels should toe in at the front about a quarter of an inch and lines drawn along the outside of the wheels when they are in a forward position should be nearly parallel. All wheels should be kept in proper alignment, otherwise steering will be difficult and tire wear greatly increased. Adjustment to make the wheels parallel can be made by turning the yoke at the left end of the spindle connecting rod or tie rod.

Very little can be done toward making any repairs on the ball bearings in the front wheels or on the roller bearings in the rear wheels because it is less expensive to replace these members when they are broken or worn than to attempt repairs. In the case of the front wheel bearings it is seldom satisfactory to replace one or more balls unless all of them are replaced, because the new balls will be larger than the others which have already received a certain amount of wear, and the new balls will, therefore, take more than their share of the load. Should either the cup or the cone be worn, or chipped, on its wearing surface, it will generally be found that one or more, if not all of the balls, are also worn, or chipped, and this condition may possibly extend to the other member of the bearing if one is found damaged.

Practically the same advice applies to the rear wheel roller bearings as applies to the front wheel

bearings, and it will almost always be better to replace the whole set of rollers together with their cage and race than to make any attempt to put in new parts.

*Tires.*—The tires may be removed, as shown in Figure 54. First, jack the wheels clear of the road. The

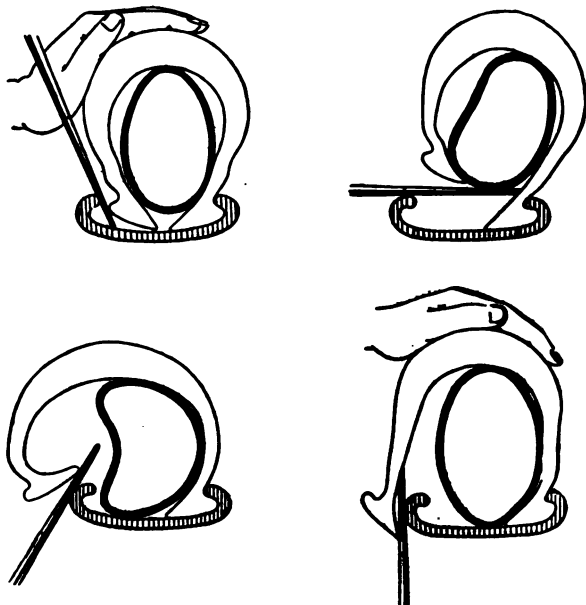

Figure 54.—Removing a Clincher Tire.

valve cap should be unscrewed, the lock nut removed and the valve stem pushed into the tire until its head is flush with the rim. This done, loosen up the bead of the casing in the clinch of the rim by working and pushing with the hands, then insert one of the tire irons or levers under the bead. The tire iron should

be pushed in just enough to get a good hold on the under side of the bead, but not so far as to pinch the inner tube between the rim and the tool. A second iron should be inserted in the same fashion some seven or eight inches from the first, and a third tool the same distance from the second. As a clincher tire must be pried over the clinch of the rim three or four levers will come in handy in a case of one-man job, and the knee of the operator can be used to good advantage to hold down one lever while the other two are being manipulated in working the casing clear of the rim. After freeing a length of the bead from the clinch, the entire outer edge of the casing may be readily detached with the hands and the damaged inner tube can be removed and patched or a spare tube inserted. Always use plenty of soapstone or powdered chalk in replacing an inner tube.

Should the casing be cut so there is danger of the inner tube being blown through it, a temporary repair can be made by cementing a canvas patch on the inside of the casing. Before applying the patch the part of the casing affected should be cleaned with gasoline, and when dry, rubber cement should be applied to both casing and patch. This will answer as an emergency repair, but the casing should be vulcanized at the first opportunity.

To prolong the life of the tire casings, any small cuts in the tread should be filled with patching cement and a specially prepared plastic compound sold by the tire companies.

Inner tube punctures may be repaired as follows: After locating the puncture, carefully clean the rubber around the leak with benzine or gasoline. Then rough the surface with sandpaper to allow the cement to

hold. Apply the cement to both patch and tube, allowing it to dry for about five minutes. Repeat the application twice with like intervals between for drying. When the cement is dry and sticky press the patch against the tube firmly and thoroughly to remove all air bubbles beneath it, and insure proper adherence to the surface. Then spread some soapstone or talc powder over the repair so as to prevent the tube from sticking to the casing. Before the tube is put back into the casing plenty of talc powder should be sprinkled into the latter. A cement patch is not permanent, and the tube should be vulcanized as soon as possible. In replacing the tire on the rim be very careful not to pinch the tube.

*Vulcanizing.*—Only the best grade of material should be used. Absolute cleanliness is necessary in all vulcanizing work. No matter how good a vulcanizer you have, or what kind of repair stock you use, the smallest amount of oil, grease or dirt will greatly impair the work. Therefore, clean every repair thoroughly with a cloth or brush dipped in clean gasoline and roughen the point of repair with a rasp or coarse sandpaper while still wet.

Tires must be dry before beginning work on them, otherwise a porous patch will result. If you think for any reason that the canvas in the casing is even slightly damp, clamp the vulcanizer loosely over the tire for ten or fifteen minutes before applying the first coat of cement. Interpose a piece of waste or something of the sort between the vulcanizer and tire to permit the escape of moisture.

It takes from fifteen to twenty minutes to vulcanize a layer of Para rubber one-sixteenth of an inch thick if the thermometer is kept at 265 degrees, and five addi-

tional minutes for each additional sixteenth of an inch. Vulcanization will occur equally well at all temperatures between 250 and 275 degrees. The lowest temperatures require more and the higher temperatures less time than stated above.

*Inner Tube Punctures.*—Clean the tube thoroughly with gasoline and coarse sandpaper for at least an inch all around the hole, being careful not to get gasoline inside the tube; then wipe with a cloth moistened with gasoline. When the gasoline has evaporated, cement the edges of the hole and apply a thin layer of cement to the tube for three-quarters of an inch on each side of the hole. Let the cement dry until all the gasoline has evaporated and the cement is solid enough to resist the touch. Tacky is the usual word. Apply a second coat and let it dry as before. If a small hole is to be repaired fill even with the surface of the tube with layers of Para rubber cut the size of the hole, taking care that the rubber sticks all around the edges. If a simple puncture, place a narrow strip of Para rubber over the end of a match and insert it into the hole. Cut off what protrudes outside the tube. Cut a patch of Para one-eighth of an inch larger than the hole or puncture and apply over the opening. Then cut another patch one-half inch larger than the hole and apply over the first. Cover and apply the vulcanizer. Repairs of this sort should be vulcanized for fifteen or twenty minutes at 265 degrees.

*Inner Tube Cuts and Tears.*—Clean as already directed, both inside and outside of the tube; coat the edges of the cut and inside and outside of the tube with cement and let it dry. The cement should extend three-fourths of an inch back from the cut.

Cut a strip of Para rubber as wide as the tube is

thick and stick on the edge of the cut. Cut another strip of rubber one-half inch wide, using rubber which is cured on one side. Place this piece inside of the tube and under the tear with the cured side down, bring the edges of the tear together and stick them down to this strip. If you do not have any of the Para cured on one side, regular Para may be used after cementing a piece of paper to the inside of the tube opposite the cut to prevent the patch from sticking to the opposite side. Apply another strip of Para rubber one-half inch wide on the outside of the repair and vulcanize for twenty-five minutes.

*Casings.*—The first step in making a casing repair is, just as in the case of all tire work, to thoroughly clean the point of repair. Apply from one to three layers of cement, allowing each to dry. If the canvas is exposed put on enough cement to fill the pores of the canvas and leave a smooth surface when dry. Fill the hole with rubber so that it is not quite level with the surface. The best results are obtained when casing repairs are slightly concave. If filled too full the rubber will expand and flow over onto the unprepared surface in a thin film that will soon peel up and cause trouble. Moreover, a protruding patch will receive more than its share of hammering and will undoubtedly split open.

Always use a sheet of waxed paper between the vulcanizer and the tire to prevent the repair from sticking to the hot iron. It is not necessary to cut away a lot of good rubber when mending small casing cuts. Leave everything except small shreds that cannot be incorporated in the repair. When cutting rubber, wet the knife and the work will go easier.

If a cemented or acid cured patch has been used to



cover the point to be repaired it must be removed, and all traces of the cement cleaned from the tube. A common spring bottom oil can filled with gasoline and an old tooth brush are handy for cleaning repairs.

When mending small casing cuts it is better to use small scraps of rubber than to try to cut layers to fit the hole. All air bubbles that appear when adding layers of rubber to fill up a cut must be punctured with an awl and pressed down flat. Do not rush the work. A few minutes spent in preparing a repair and vulcanizing it may save considerable trouble later.

When properly cured, a repair should be gray in color, and should not retain an indentation made by the finger nail. The longer a repair is vulcanized and the higher the temperature maintained, the harder the patch becomes. If a patch simply seems too soft, apply the vulcanizer a few minutes longer. In case it seems necessary to increase the cure, it is better to add to the time than to the temperature. Under-curing is always preferable to over-curing.

If a poor patch is made it is best to remove it entirely, recoating the hole with cement and filling with fresh rubber. A porous patch is caused by a damp tire, by failure to let the gasoline evaporate after cleaning the tire, by failure to let the cement dry or by air-pockets between the layers. It may also be caused by too high a temperature. The latter cause makes a patch hard and brittle.

Do not inflate inner tubes until after they have cooled, for a bulge is liable to be the result. Your tire pump makes an excellent bellows for cleaning the dirt from sand-pockets or casing cuts, as well as for drying the gasoline after washing the canvas.

## CHAPTER VII

### TROUBLES, SYMPTOMS AND REMEDIES

The process of locating and remedying motor car troubles may be simplified and rendered comparatively easy by a systematic classification of the symptoms. With such a classification as a guide it is possible to eliminate the most probable causes, and gradually work through the list until the particular trouble which exists is located.

For convenience in explaining the operation of such a method we will divide all power plant faults into seven groups as follows:

1. Failure of the engine to start.
2. Sudden stopping of the engine.
3. Engine loses power.
4. Engine overheats.
5. Engine is noisy.
6. Ignition trouble.
7. Carburetor trouble.

Any one of the first five symptoms may be easily recognized, but the last two are sometimes more difficult to determine, because either one of them, or a combination of the two, may produce one or more of the first five.

#### FAILURE OF ENGINE TO START

In case the engine will not start, the operator should first make sure that the switch on the coil is turned

either to the BAT position or toward the MAG position, because experienced drivers have been known to crank for a long while with either one of these simple troubles present. It is also possible that the gasoline cannot flow through the carburetor because the supply valve underneath the fuel tank is closed.

In case the vibrators on the coils have been adjusted or tampered with it is quite possible that the points have been set too close together so that no spark is produced, and in this case it will be necessary to re-adjust them according to the directions given in another part of this book.

It might be well at this point to disconnect one of the wires from a spark plug and lay it in such a position that the metal end on the wire is supported within about one-eighth of an inch of some metal part of the power plant. With the switch turned on the engine should be cranked, and if a spark passes from the end of the wire to the metal of the engine the ignition system is in working order. If no spark is visible it will be well to lift the floor boards and take the contact terminal for the magneto out of its position above the flywheel, because it is quite often found that the lower end of this contact is covered with some foreign matter which prevents the flow of current through it. If this contact is in good condition, and clean, the commutator should be examined to see that it is free from water or congealed oil, and if these troubles are not present and still no spark is secured, the section of this Chapter which refers to ignition trouble should be consulted.

If with the spark plug disconnected and held close to some metal surface a good spark is noted to pass, it may be assumed that the trouble lies with the fuel

system, and the carburetor adjustment on the dash should be closed by turning it to the right and should then be reopened about one turn.

If this does not remedy the matter the drain cock below the sediment bulb under the gasoline tank should be opened because it is quite possible that there is water in this bulb. The drain cock on the carburetor should also be opened momentarily for the same reason. In cold weather it may be found that water in the sediment bulb, or in the carburetor, has frozen, thus stopping the flow of fuel.

#### SUDDEN STOPPING OF ENGINE

In case the engine comes to a more or less sudden stop the gasoline tank should be looked into to see that there is a supply of fuel, and if gasoline is present it is next in order to lift the hood and see that no wires are loose or broken.

The floor boards should be taken up and the wire which is attached to the magneto terminal on top of the flywheel case should be followed from this point to the coil terminal, and it should be tightly secured at both ends. The magneto contact terminal should be removed and examined to see that it is clean.

It is possible that the carburetor adjustment on the dash has jarred from its correct position, and has reduced the supply of fuel in the mixture to a point that stops the engine. This adjustment should be turned to the right until the needle valve is closed, and should then be given one full turn to the left.

After the engine comes to a stop the hood should be lifted and the carburetor watched to see whether liquid fuel in considerable quantities is dropping from it, and if this is the case, it indicates that the float valve in

the carburetor is sticking open. This condition may be remedied in most cases by tapping the body of the carburetor with a piece of wood. If the flooding still continues it will be necessary to close the supply valve underneath the gasoline tank and disassemble the carburetor until the float valve mechanism is reached, when the trouble present may be easily remedied because it will generally be found that a piece of dirt has lodged between the float valve and the seat. If tapping the carburetor causes the flooding to stop, the engine may be started, first closing the adjustment on the dash by turning it to the right and then cranking. After the crank has been given several revolutions the dash adjustment should be given one full turn to the left, after which the engine should start.

In case none of the above mentioned troubles are present the fuel line should be disconnected from the carburetor, and the flow of liquid noted. In case there is no flow, or in case the flow is in a very small stream, the pipe should be disconnected from the tank end and blown through by placing the lips at the carburetor end. This will dislodge any obstacles that may have entered the fuel line.

It may also be found that some foreign substance is obstructing the opening in the tank which leads to the sediment bulb and fuel line. This has been known to happen when inner tube patches drop into the tank through the filler opening. The engine may have been brought to a stop by water in the gasoline, and this water may be gotten rid of by opening the drain cock on the carburetor or underneath the sediment bulb below the fuel tank.

If the engine labored and seemed to be losing power

before it came to a stop the trouble may be due to lack of water in the radiator, or to lack of cylinder oil, and either one of these conditions suggests its remedy.

A sudden stoppage of the engine may be due to almost any of the troubles mentioned in the sections of this Chapter devoted to ignition and carburetor faults, and if no remedy has been effective, these sections should be consulted.

#### ENGINE LOSES POWER

This division of trouble may be subdivided into two parts, one of which will cover those occurring at low speed, and the other those found at high speed.

The most probable source of low speed trouble is in loss of compression, and this loss may be due to any one of many causes. The compression of each cylinder should be tested by turning the starting crank with the ignition switch in the off position and noting the resistance to cranking as the compression stroke for each cylinder is reached. Should the crank turn comparatively easy during any one-half revolution it will be well to remove the spark plugs from all but one cylinder. Then crank the engine again and notice whether there is a decided resistance to turning once in every two complete revolutions. If such a resistance is found to be present the spark plug should be removed from the one cylinder in which it has been allowed to remain, and a plug should be replaced in one of the other three cylinders, and the cranking operation again gone through with. When it is found that with a spark plug in place there is insufficient compression to cause the crank to spring backward when it is brought to a certain point in turning, it indicates that the cylinder in which the plug is then inserted is los-

be pushed in just enough to get a good hold on the under side of the bead, but not so far as to pinch the inner tube between the rim and the tool. A second iron should be inserted in the same fashion some seven or eight inches from the first, and a third tool the same distance from the second. As a clincher tire must be pried over the clinch of the rim three or four levers will come in handy in a case of one-man job, and the knee of the operator can be used to good advantage to hold down one lever while the other two are being manipulated in working the casing clear of the rim. After freeing a length of the bead from the clinch, the entire outer edge of the casing may be readily detached with the hands and the damaged inner tube can be removed and patched or a spare tube inserted. Always use plenty of soapstone or powdered chalk in replacing an inner tube.

Should the casing be cut so there is danger of the inner tube being blown through it, a temporary repair can be made by cementing a canvas patch on the inside of the casing. Before applying the patch the part of the casing affected should be cleaned with gasoline, and when dry, rubber cement should be applied to both casing and patch. This will answer as an emergency repair, but the casing should be vulcanized at the first opportunity.

To prolong the life of the tire casings, any small cuts in the tread should be filled with patching cement and a specially prepared plastic compound sold by the tire companies.

Inner tube punctures may be repaired as follows: After locating the puncture, carefully clean the rubber around the leak with benzine or gasoline. Then rough the surface with sandpaper to allow the cement to

hold. Apply the cement to both patch and tube, allowing it to dry for about five minutes. Repeat the application twice with like intervals between for drying. When the cement is dry and sticky press the patch against the tube firmly and thoroughly to remove all air bubbles beneath it, and insure proper adherence to the surface. Then spread some soapstone or talc powder over the repair so as to prevent the tube from sticking to the casing. Before the tube is put back into the casing plenty of talc powder should be sprinkled into the latter. A cement patch is not permanent, and the tube should be vulcanized as soon as possible. In replacing the tire on the rim be very careful not to pinch the tube.

*Vulcanizing.*—Only the best grade of material should be used. Absolute cleanliness is necessary in all vulcanizing work. No matter how good a vulcanizer you have, or what kind of repair stock you use, the smallest amount of oil, grease or dirt will greatly impair the work. Therefore, clean every repair thoroughly with a cloth or brush dipped in clean gasoline and roughen the point of repair with a rasp or coarse sandpaper while still wet.

Tires must be dry before beginning work on them, otherwise a porous patch will result. If you think for any reason that the canvas in the casing is even slightly damp, clamp the vulcanizer loosely over the tire for ten or fifteen minutes before applying the first coat of cement. Interpose a piece of waste or something of the sort between the vulcanizer and tire to permit the escape of moisture.

It takes from fifteen to twenty minutes to vulcanize a layer of Para rubber one-sixteenth of an inch thick if the thermometer is kept at 265 degrees, and five addi-



tional minutes for each additional sixteenth of an inch. Vulcanization will occur equally well at all temperatures between 250 and 275 degrees. The lowest temperatures require more and the higher temperatures less time than stated above.

*Inner Tube Punctures.*—Clean the tube thoroughly with gasoline and coarse sandpaper for at least an inch all around the hole, being careful not to get gasoline inside the tube; then wipe with a cloth moistened with gasoline. When the gasoline has evaporated, cement the edges of the hole and apply a thin layer of cement to the tube for three-quarters of an inch on each side of the hole. Let the cement dry until all the gasoline has evaporated and the cement is solid enough to resist the touch. Tacky is the usual word. Apply a second coat and let it dry as before. If a small hole is to be repaired fill even with the surface of the tube with layers of Para rubber cut the size of the hole, taking care that the rubber sticks all around the edges. If a simple puncture, place a narrow strip of Para rubber over the end of a match and insert it into the hole. Cut off what protrudes outside the tube. Cut a patch of Para one-eighth of an inch larger than the hole or puncture and apply over the opening. Then cut another patch one-half inch larger than the hole and apply over the first. Cover and apply the vulcanizer. Repairs of this sort should be vulcanized for fifteen or twenty minutes at 265 degrees.

*Inner Tube Cuts and Tears.*—Clean as already directed, both inside and outside of the tube; coat the edges of the cut and inside and outside of the tube with cement and let it dry. The cement should extend three-fourths of an inch back from the cut.

Cut a strip of Para rubber as wide as the tube is

thick and stick on the edge of the cut. Cut another strip of rubber one-half inch wide, using rubber which is cured on one side. Place this piece inside of the tube and under the tear with the cured side down, bring the edges of the tear together and stick them down to this strip. If you do not have any of the Para cured on one side, regular Para may be used after cementing a piece of paper to the inside of the tube opposite the cut to prevent the patch from sticking to the opposite side. Apply another strip of Para rubber one-half inch wide on the outside of the repair and vulcanize for twenty-five minutes.

*Casings.*—The first step in making a casing repair is, just as in the case of all tire work, to thoroughly clean the point of repair. Apply from one to three layers of cement, allowing each to dry. If the canvas is exposed put on enough cement to fill the pores of the canvas and leave a smooth surface when dry. Fill the hole with rubber so that it is not quite level with the surface. The best results are obtained when casing repairs are slightly concave. If filled too full the rubber will expand and flow over onto the unprepared surface in a thin film that will soon peel up and cause trouble. Moreover, a protruding patch will receive more than its share of hammering and will undoubtedly split open.

Always use a sheet of waxed paper between the vulcanizer and the tire to prevent the repair from sticking to the hot iron. It is not necessary to cut away a lot of good rubber when mending small casing cuts. Leave everything except small shreds that cannot be incorporated in the repair. When cutting rubber, wet the knife and the work will go easier.

If a cemented or acid cured patch has been used to

cover the point to be repaired it must be removed, and all traces of the cement cleaned from the tube. A common spring bottom oil can filled with gasoline and an old tooth brush are handy for cleaning repairs.

When mending small casing cuts it is better to use small scraps of rubber than to try to cut layers to fit the hole. All air bubbles that appear when adding layers of rubber to fill up a cut must be punctured with an awl and pressed down flat. Do not rush the work. A few minutes spent in preparing a repair and vulcanizing it may save considerable trouble later.

When properly cured, a repair should be gray in color, and should not retain an indentation made by the finger nail. The longer a repair is vulcanized and the higher the temperature maintained, the harder the patch becomes. If a patch simply seems too soft, apply the vulcanizer a few minutes longer. In case it seems necessary to increase the cure, it is better to add to the time than to the temperature. Under-curing is always preferable to over-curing.

If a poor patch is made it is best to remove it entirely, recoating the hole with cement and filling with fresh rubber. A porous patch is caused by a damp tire, by failure to let the gasoline evaporate after cleaning the tire, by failure to let the cement dry or by air-pockets between the layers. It may also be caused by too high a temperature. The latter cause makes a patch hard and brittle.

Do not inflate inner tubes until after they have cooled, for a bulge is liable to be the result. Your tire pump makes an excellent bellows for cleaning the dirt from sand-pockets or casing cuts, as well as for drying the gasoline after washing the canvas.

## CHAPTER VII

### TROUBLES, SYMPTOMS AND REMEDIES

The process of locating and remedying motor car troubles may be simplified and rendered comparatively easy by a systematic classification of the symptoms. With such a classification as a guide it is possible to eliminate the most probable causes, and gradually work through the list until the particular trouble which exists is located.

For convenience in explaining the operation of such a method we will divide all power plant faults into seven groups as follows:

1. Failure of the engine to start.
2. Sudden stopping of the engine.
3. Engine loses power.
4. Engine overheats.
5. Engine is noisy.
6. Ignition trouble.
7. Carburetor trouble.

Any one of the first five symptoms may be easily recognized, but the last two are sometimes more difficult to determine, because either one of them, or a combination of the two, may produce one or more of the first five.

#### FAILURE OF ENGINE TO START

In case the engine will not start, the operator should first make sure that the switch on the coil is turned

either to the BAT position or toward the MAG position, because experienced drivers have been known to crank for a long while with either one of these simple troubles present. It is also possible that the gasoline cannot flow through the carburetor because the supply valve underneath the fuel tank is closed.

In case the vibrators on the coils have been adjusted or tampered with it is quite possible that the points have been set too close together so that no spark is produced, and in this case it will be necessary to re-adjust them according to the directions given in another part of this book.

It might be well at this point to disconnect one of the wires from a spark plug and lay it in such a position that the metal end on the wire is supported within about one-eighth of an inch of some metal part of the power plant. With the switch turned on the engine should be cranked, and if a spark passes from the end of the wire to the metal of the engine the ignition system is in working order. If no spark is visible it will be well to lift the floor boards and take the contact terminal for the magneto out of its position above the flywheel, because it is quite often found that the lower end of this contact is covered with some foreign matter which prevents the flow of current through it. If this contact is in good condition, and clean, the commutator should be examined to see that it is free from water or congealed oil, and if these troubles are not present and still no spark is secured, the section of this Chapter which refers to ignition trouble should be consulted.

If with the spark plug disconnected and held close to some metal surface a good spark is noted to pass, it may be assumed that the trouble lies with the fuel

system, and the carburetor adjustment on the dash should be closed by turning it to the right and should then be reopened about one turn.

If this does not remedy the matter the drain cock below the sediment bulb under the gasoline tank should be opened because it is quite possible that there is water in this bulb. The drain cock on the carburetor should also be opened momentarily for the same reason. In cold weather it may be found that water in the sediment bulb, or in the carburetor, has frozen, thus stopping the flow of fuel.

#### SUDDEN STOPPING OF ENGINE

In case the engine comes to a more or less sudden stop the gasoline tank should be looked into to see that there is a supply of fuel, and if gasoline is present it is next in order to lift the hood and see that no wires are loose or broken.

The floor boards should be taken up and the wire which is attached to the magneto terminal on top of the flywheel case should be followed from this point to the coil terminal, and it should be tightly secured at both ends. The magneto contact terminal should be removed and examined to see that it is clean.

It is possible that the carburetor adjustment on the dash has jarred from its correct position, and has reduced the supply of fuel in the mixture to a point that stops the engine. This adjustment should be turned to the right until the needle valve is closed, and should then be given one full turn to the left.

After the engine comes to a stop the hood should be lifted and the carburetor watched to see whether liquid fuel in considerable quantities is dropping from it, and if this is the case, it indicates that the float valve in

the carburetor is sticking open. This condition may be remedied in most cases by tapping the body of the carburetor with a piece of wood. If the flooding still continues it will be necessary to close the supply valve underneath the gasoline tank and disassemble the carburetor until the float valve mechanism is reached, when the trouble present may be easily remedied because it will generally be found that a piece of dirt has lodged between the float valve and the seat. If tapping the carburetor causes the flooding to stop, the engine may be started, first closing the adjustment on the dash by turning it to the right and then cranking. After the crank has been given several revolutions the dash adjustment should be given one full turn to the left, after which the engine should start.

In case none of the above mentioned troubles are present the fuel line should be disconnected from the carburetor, and the flow of liquid noted. In case there is no flow, or in case the flow is in a very small stream, the pipe should be disconnected from the tank end and blown through by placing the lips at the carburetor end. This will dislodge any obstacles that may have entered the fuel line.

It may also be found that some foreign substance is obstructing the opening in the tank which leads to the sediment bulb and fuel line. This has been known to happen when inner tube patches drop into the tank through the filler opening. The engine may have been brought to a stop by water in the gasoline, and this water may be gotten rid of by opening the drain cock on the carburetor or underneath the sediment bulb below the fuel tank.

If the engine labored and seemed to be losing power

before it came to a stop the trouble may be due to lack of water in the radiator, or to lack of cylinder oil, and either one of these conditions suggests its remedy.

A sudden stoppage of the engine may be due to almost any of the troubles mentioned in the sections of this Chapter devoted to ignition and carburetor faults, and if no remedy has been effective, these sections should be consulted.

#### ENGINE LOSES POWER

This division of trouble may be subdivided into two parts, one of which will cover those occurring at low speed, and the other those found at high speed.

The most probable source of low speed trouble is in loss of compression, and this loss may be due to any one of many causes. The compression of each cylinder should be tested by turning the starting crank with the ignition switch in the off position and noting the resistance to cranking as the compression stroke for each cylinder is reached. Should the crank turn comparatively easy during any one-half revolution it will be well to remove the spark plugs from all but one cylinder. Then crank the engine again and notice whether there is a decided resistance to turning once in every two complete revolutions. If such a resistance is found to be present the spark plug should be removed from the one cylinder in which it has been allowed to remain, and a plug should be replaced in one of the other three cylinders, and the cranking operation again gone through with. When it is found that with a spark plug in place there is insufficient compression to cause the crank to spring backward when it is brought to a certain point in turning, it indicates that the cylinder in which the plug is then inserted is los-



ing compression for one of the reasons mentioned hereafter.

It is possible for the mixture to leave the combustion space because of defective spark plugs, defective valves or valve operation, defective cylinder head gaskets, leaks between the piston rings and cylinder walls, or through a leak in the cylinder casting itself.

A test may be made for leaks around the spark plug threads by placing cylinder oil around these joints and then cranking the engine. Bubbles will show the location of any of these leaks. If leaks are present the plug may be loose or some of the threads may be broken either on the plug or in the cylinder casting.

The central part of the spark plug should be grasped and moved if possible. A broken porcelain will allow the gas to leak and a new one is the only remedy. If the porcelain or mica part of the plug is loose in the shell the packing nut should be screwed down, but should not be turned so hard that it will break the insulating member of the plug.

Should the large gasket between the removable cylinder head and the body of the cylinder casting be defective, the condition will probably be indicated by water leaks, either on the outside of the engine or into the combustion space. Water leaks into the combustion space will be found upon the removal of the spark plug in the first place because the water will be thrown out, or at least a few drops will be noticed when the engine is cranked. The only satisfactory way to remedy such a condition is to remove the cylinder head and replace the old gasket with a new one.

If the compression remains poor after the above mentioned points have been checked the trouble will probably be found due to dirty valves or to some defect

in the valve operation. This will call for the removal of the cylinder head, after which it will be possible to examine the faces of the valves and their seats in the cylinder castings to see that they are clean. It will often be found that small particles of carbon have lodged between the valves and the seats so that the gas is allowed to escape. This means that the valve should be ground.

With the cylinder head removed the engine should be cranked and the valves watched as they move up and down. If they are sluggish in their action, or if one of the valves does not close, the spring should be removed and the stem of the valve should be examined and cleaned, if necessary. With the valve removed from the cylinder it should be laid with the stem on a flat table top, or other flat surface, and rolled. As the stem rolls over the surface it may be noted whether it is bent. If the stem is found to be warped out of shape it should be replaced with a new one.

The face of the valve and its seat should be examined for pitting or score marks, and unless these surfaces are found to be smooth the valve should be carefully ground. The valve may also be held a slight distance from its seat by a shoulder which has been worn into the metal of the valve stem, or because of a shoulder or a ring which has been formed on the face of the valve. Either of these last mentioned troubles requires that the valve be placed in a lathe and the face or stem turned to a true surface.

While the valves are being examined it will be easy to note such troubles as a broken stem, a cracked valve head or a cracked valve seat, and it should also be noted whether the valve spring fastenings were loose, or whether the valve adjustments, if any are used, were

out of order. These troubles either require a remedy which is perfectly evident, or else call for new parts.

If the valves are found to be in good order it is possible that the compression leak is between the piston rings and the cylinder walls. This may be caused by scratches or score marks and to remedy this condition it will be necessary to rebore the old cylinders, or else to replace them with a new block. It is also possible that the cylinders have been cracked by freezing of the cooling water, and the best remedy for this will be new cylinders. In case the water has been frozen it is possible that the cylinder head casting has been cracked, and this, of course, would lead to results equally as bad as those coming from cracked cylinders.

If the piston rings are not bearing evenly against the cylinder walls the condition will be made apparent by black patches, or lines, on the walls, and it will probably be best to replace the old rings with new ones. New rings require a certain length of time to wear to a proper fit, and the best results should not be expected until this time has elapsed. In case the openings, or slots, through the sides of the rings on any one piston have been moved into such position that they are almost directly above one another, it is quite probable that a loss of compression will result, and this loss may be stopped by moving the rings so that the openings are equally spaced from each other around the outside of the piston.

A loss of power may be occasioned by some classes of valve trouble which will not result in a loss of compression. The most common of this class of troubles is too great a clearance between the lower end of the valve stem and the upper end of the push rod which

lifts it. In case the push rods are not of the adjustable type it will be best to secure a new valve, or a new rod, depending on which one is too short. This clearance should be but little greater than the thickness of a heavy piece of wrapping paper, and if it is too great, the valve will not have sufficient lift to admit a full charge of gas. A rare trouble, and one which is fortunately seldom encountered, is that in which the upper end of the valve lifter, or push rod, is worn hollow so that the valve stem drops into this hollow and produces the same trouble as would be brought about by too great a clearance between the stem and the rod.

Fuel trouble may cause a loss of power, and such trouble is probably due to an incorrect carburetor adjustment. The adjustment should be made right, according to the instructions given in another part of this book. A rather peculiar trouble of this general class is that caused by an air leak into the inlet manifold. The dilution of the mixture that results will materially reduce the power. Such a leak may be easily located by securing a squirt can filled with gasoline, and while the engine is running, spraying the liquid on the inlet manifold and at the joints between the manifold and cylinder, and between the manifold and the carburetor. The engine will run evenly until the liquid gasoline strikes an air leak, and when this happens, the additional fuel which will be drawn into the manifold will cause the engine to run either slower or faster. When this happens the point at which the liquid is being thrown should be examined, and if it is at a joint, this joint should be remade with a new gasket. If the leak is in the manifold proper it may be welded, or else a new manifold may be secured.

A loss of power may be found to be due to an incorrect adjustment of the vibrators on the coils, or it may be due to a faulty spark plug. The spark plug should be removed and the surfaces of the insulating core, which extend inside the combustion space end of the plug, should be cleaned with gasoline and a stiff brush. At this same time the gap between the spark plug points should be examined, and should be made equal to about one-thirty-second of an inch. Too little gap between these points will cause a loss of power at low speeds.

Loss of power at high engine speed may possibly be due to some of the causes already mentioned for low speed action, but it is more likely that the trouble will be found among those that will now be mentioned. The carburetor adjustment should be tested and a greater opening should be tried, that is, the engine should be run with the dash adjustment turned farther to the left.

The spark plugs should be removed and the spaces between their points examined. If these gaps are greater than one-thirty-second of an inch there will be loss of power at high speed. The contact between the commutator roller and the contact segments inside of the commutator shell should be examined, and if the surfaces are in such condition that a poor contact is made, the effect will be most noticeable at high speed. The best remedy will be either a new roller or a new shell, or both. The contacts of the coil vibrator should be examined and cleaned if they are at all dirty, because dirt at this point will reduce the current flow and will affect high speed operation when all of the available electricity is needed.

All of the exhaust valve springs in any one engine

should have equal strength. The springs may be tested by placing two of them end to end and pressing them together. If either spring being tested compresses to a greater degree than the other one, it should be replaced with a spring which shows the proper strength.

When the valves fail to seat themselves properly there is a possibility that the springs may be weak or broken. A weak inlet spring would probably not affect the running of the engine, but weakness in the exhaust valve spring causes a very uneven action, which is difficult to locate. The symptoms are a lag in the engine, due to the exhaust valve not closing instantaneously, and as a result a certain percentage of charge under compression escapes, greatly diminishing the force of the explosion.

Weakness in a valve spring can usually be detected by the following method: Remove the plate which encloses them at the side of the cylinder and insert a screwdriver between the coils of the springs while the engine is running. If the extra tension thus produced causes the engine to pick up speed, the spring is obviously weak and should be replaced with a new one.

There are certain troubles which will cause a loss of power at high speed, and which require a certain amount of disassembling of the engine to locate them. These troubles include looseness of the timing gears, either on one end of the camshaft or on the end of the crankshaft. The camshaft itself may have been bent or sprung, in which case it will be best to get a new one. It may be found that the cams, the push rods, the push rod guides or the camshaft bearings have become so badly worn that the valve opening is imperfect and a loss of power results.

## ENGINE OVERHEATS

In case the engine becomes so hot that the water in the radiator steams, the carburetor adjustment should be examined, and if the engine will continue to run smoothly the adjustment on the dash should be turned just as far to the right as it will go, or until a noticeable falling off in power results. The driving conditions may be responsible for the trouble if the spark lever is not advanced or brought toward the driver far enough. It will be remembered that the spark should be carried advanced just as far as possible without causing the engine to knock.

Overheating may be caused by dirty spark plugs, and it is advisable that they be removed from the cylinder and cleaned as a precaution, if for no other reason. If the engine has been run with an excessively rich mixture, or with an over-supply of oil, the piston head and the surfaces of the combustion chamber may have become so covered with carbon as to cause heating. This carbon may be removed by burning with oxygen, or taking off the cylinder head and scraping it away. After this is done the oil level should be made right, and the carburetor mixture should be properly adjusted.

The natural place to look for overheating is in the cooling system, and many of these troubles will be found there. The level of the water in the radiator should first be noted, and if it is low for any reason, the supply should be replenished and any leaks in the radiator or in the piping should be repaired.

The fan belt may be torn, or the adjustment may have become loosened so that the fan does not run with sufficient speed. If the belt is worn, or damaged,

it should be renewed, and if the belt is found to be loose the adjustment should be made tighter. It may be found that the fan bearing is binding because of lack of oil. It may be sufficient to give the grease cup a few turns, but it will generally be best to take the bearing apart, clean it, and give it proper lubrication.

The hose between the top or bottom of the radiator and the engine may be kinked, or may be rotted and loose inside. In case it is kinked it should be shortened and straightened out. If it is rotted it, of course, should be renewed. It may be found that the gaskets at the joints between the engine and the hose fittings have been replaced with new ones of soft material, which may have swollen to form an obstruction to the flow of water.

The outside of the radiator should be cleaned of any deposit of dirt, oil or scale that may have collected, and this cleaning can best be done with gasoline, or water, and a good, stiff brush.

No harm will be done should the water boil occasionally while driving through mud or deep sand, or up long hills in hot weather; however, if there is a continual overheating with the engine running under ordinary conditions the cause should be found and the remedy applied. The cause may be in too much driving in low gear, or because of a poor grade of oil, or an insufficient supply of oil. Racing the engine will also result in overheating. One cause of heating which is often overlooked is that due to a clogged muffler, or to a muffler full of soot and carbon. Such a condition results in excessive back pressure and prevents a proper exhausting of the burned gas so that the heat is retained in the engine and must be taken care of by the cooling water.



The radiator and cylinder jackets may be freed from any deposit of dirt and scale by the following method: Secure five pounds of caustic soda from a laundry supply house and add the soda slowly to a pail of water until the solution makes two and one-half gallons. This means that a sufficient quantity should be used to dissolve the five pounds of soda and to result in a total quantity of mixture equal to two and one-half gallons. Drain the cooling water and pour this solution into the radiator. Then run the engine for about five minutes and again open the drain-cock. After the solution has left the cooling system, wash out the radiator and jackets with several fillings of clean water. This caustic is very poisonous and will quickly burn the flesh of the one using it should any of the solution get on the hands. Great care should, therefore, be used in handling the mixture.

If the cooling system is in good order the trouble may be due to improper oiling. The oil may be of poor quality, which is the worst possible form of economy, or else it may be too heavy or too light. The oil may have become so old and dirty as to have lost most of its lubricating qualities and it should be drained away and replaced with a fresh supply.

The power plant should be carefully examined for oil leaks which lower the level. The pet-cocks on the flywheel case should be opened and the oil should be high enough to flow out of the lower cock. If there is plenty of good oil present and the engine seems to drag and bind, together with the overheating, it is possible that the oil pipe inside of the engine is leaking, bent or clogged. The only way to check this condition will be to disassemble the engine sufficiently to remove the pipe and blow through it.

## ENGINE NOISE

In case of any noise becoming noticeable in the power plant the first thing to do is to examine the oil supply and see that it is sufficient. In case the noise is evident as a clicking or a rattling, the following points should be checked. First look at the fan to see that none of its blades are hitting some other part of the power plant. A clicking which keeps time with the engine may be caused by too much clearance between the lower end of the valve stem and the valve lifter, and the remedy for this condition has already been explained. While examining the clearance the valve stem should be pulled back and forth to see that the guide has not become excessively worn and a similar test should be applied to the guides for the valve lifters.

A hissing noise will be caused by any leakage of gas or of the exhaust around the spark plugs or any of the manifold gaskets. In the case of the piston rings being completely broken, it would be possible to notice the escape of the gas by the hissing sound caused as it enters the crankcase, but it is not probable that this condition would be located by this noise but rather by the lack of power which would be the immediate result.

Noises in the engine which may be classed as knocks or pounds may be the result of any one of a long list of troubles. The most probable fault is that pre-ignition is occurring because of red hot pieces of carbon which have collected in the combustion space. This form of trouble will cause a clear sharp knock or rapping sound. It is possible to cause knocking by driving the car with the spark too far advanced and

the obvious remedy is to carry the lever in a more retarded position.

Looseness in any of the engine bearings will cause various kinds of knocks and pounds. The most common point at which such trouble will be found is at the lower end of the connecting rods and the resulting noise will be especially noticeable when running at high speed or when running at a moderate speed down grade and with the engine exerting very little effort. Looseness of the crankshaft bearings will cause a dull thud whenever the engine is pulling hard. Looseness at the upper end of the connecting rod; that is, in the wrist pin bearings, will be noticed because of a peculiar sharp tapping which seems to come from a point near the upper end of the cylinder castings. Loose camshaft bearings may also cause knocking under certain conditions, and if either the camshaft or crankshaft are sprung out of line, the result will be a loosening of the bearings which will make a noticeable knock.

In case of any of the bolts holding the several parts of the engine and power plant together become loose, a very disagreeable noise will result. The points at which such looseness may occur are in the bolts which hold the engine to the frame, in the bolts which hold the cylinder head onto the cylinder block, in the bolts which hold the flywheel to the end of the crankshaft and camshaft.

Wear in the teeth of the timing gears will result in a continuous high pitched sound which will increase in intensity with the engine speed. Wear of the pistons or in the cylinders will result in a sharp rattle or in a slapping noise whenever the engine speed is suddenly increased. A broken piston ring

will make a noise of similar character. Excessive vibration of the engine may be caused by incorrect assembling especially in case the engine has been taken apart and the flywheel replaced in the wrong position with reference to the crankshaft. The flywheel is balanced with the engine, and before it is removed for any reason, its position in relation to the crankshaft should be carefully noticed and it should always be replaced in this position.

Various noises may be caused by insufficient clearance between some of the moving parts of the engine and power plant. One rather common cause for this trouble is that which results from the use of spark plugs whose shells extend down into the cylinder for too great a distance. This may result in the valve striking the spark plug. A knock will also result in case the cylinder head gasket has been replaced in such a position that it extends out over the upper edge of the cylinder walls because this extended portion will be struck by the piston once in every stroke. Should the under pan or crankcase of the engine have become bent or dented it may be possible that the lower end of the connecting rod is striking it, and the result will of course be a sharp knock for every revolution of the crankshaft.

#### IGNITION TROUBLE

An uneven sputter and bang of the exhaust means that one or more cylinders are firing irregularly or not at all, and that the trouble should be promptly located and overcome. Misfiring, if allowed to continue, will in time injure the engine and the entire mechanism. A good driver will be satisfied only with

a soft, steady purr from the exhaust. If anything goes wrong, stop and fix it at once if possible.

To find the missing cylinder take a wood-handled screwdriver or a hammer, and while the engine is running, lay the screwdriver blade or the hammer head from the top of the spark plug to the cylinder so that the current goes through the screwdriver or hammer head in place of across the gap in the plug.

If the cylinder being tested was firing you will notice the engine slow down; but if the cylinder was not firing, it will make no difference when the plug is short-circuited in this way.

To test the spark remove a spark plug and connect its wire to it. Lay the plug on top of the cylinder with the threads touching the metal, but do not let the top of the plug or the wire touch the engine. By cranking with the switch turned on you can now see the spark jump across the gap. Sometimes a spark that will jump through the air as above will not jump through the compressed gas. If a spark will jump from the end of the wire a distance of one-fourth inch it should jump the gap while in the cylinder.

The missing cylinder may also be located by manipulating the vibrators on the spark coils. Open the throttle until the engine is running at a good speed and then hold down the two outside vibrators, number one and number four, with the fingers, so they cannot buzz. This cuts out the two corresponding cylinders, number one and number four, leaving only number two and number three running. If they fire regularly it is obvious the trouble is in either number one or number four. Relieve number four and hold down number two and number three and also num-

ber one. If number four cylinder fires evenly it is evident the misfiring is in number one. In this manner all of the cylinders in turn can be tested until the trouble is located. Examine both the spark plug and the vibrator of the missing cylinder.

If ignition trouble still remains it will be advisable to examine the spark plug of the cylinder which misses fire or to examine all the plugs. See that the points between which the spark jumps are free from dirt, oil or water and that they are neither too far apart nor too close together. It will be remembered that these points should be separated by  $\frac{1}{8}$  inch. The porcelain or mica insulation may have become covered with dirt on the outside of the combustion space or with oil or soot on the ends which extend toward the inside of the cylinder. The insulation should be cleaned with gasoline and a cloth or stiff brush.

Carbon deposit on the spark plugs may be loosened by allowing them to soak in kerosene for several hours. While the plugs are being examined it should be noted whether the porcelain is cracked or broken, and if either of these conditions is present the porcelain should be replaced with a new one. In the case of a mica plug it is possible that the oil has crept in between the layers of mica and is causing a short-circuit. This is especially likely to be true of old plugs. The spark plugs should be examined to see that the points are not loose in the shell or in the insulating core and also to see that the core is not loose in the shell, as this would produce the same result as a loose point, namely, an incorrect gap.

There are but few troubles that can affect the Ford magneto and the most common one of these is that caused by dirt collecting at the lower end of the con-

tact which is fastened in the flywheel housing just above the wheel and underneath the floor boards.

If the car has been in use a considerable length of time, or if the engine has been disassembled and put back together, it is possible that the flywheel magnets have become weakened and in this case it will be best to replace them with new ones. If the magnets have been removed from the flywheel they may have been replaced wrongly with respect to their polarity. The magnets should be assembled on the wheel in such relation to each other that the negative poles of adjacent magnets are next to each other and this will likewise bring the positive poles of adjacent magnets together. The simplest way to make sure that this condition exists is to hold the magnets close to each other while they are off the flywheel and pick the poles or ends which do not stick to each other because of the magnetism. If two magnets are held in this way with one end of one magnet close to one end of the other and it is found that these ends have no tendency to be drawn together then they are both of the same polarity, either positive or negative, and they should be placed on the flywheel with these ends close together.

Should the insulation of the primary wires running from the coil to the commutator become worn to such an extent that the copper wire is exposed, the current will leak out or short-circuit whenever contact with the engine pan or other metal parts is made. A steady buzzing of one of the coil units will indicate a short in the wiring. When driving the car the engine will suddenly lag and pound on account of the premature explosion. Be careful not to crank the engine downward against the compression when the car is in this

condition, as the short is apt to cause a vigorous kick back.

The wires should be examined to see that none of them are disconnected and special notice should be given to those connected with the timer or commutator. The wiring should be examined to see that there are no loose terminals or loose ends at any point and that none of the ends or terminals are rubbing against metal parts of the power plant. It will sometimes be found that a wire is broken underneath the insulation and this will lead to trouble, the cause of which is very hard to locate. The only way in which such a wire may be found is by taking them one at a time and pulling while the engine is running. If pulling on any one wire causes misfiring it would indicate that this wire is defective underneath the insulation. All of the wiring should be kept clean and dry and if any of it is found to be covered with dirt or oil soaked it will be best to renew these parts.

The wires leading from the coil to the spark plugs may have become attached to the plugs in the wrong order, that is, an order which does not correspond to that in which the engine fires. It has been explained that the firing of the Ford engine is 1, 2, 4, 3, and if the wires are attached so that the order of sparking at the plugs is different from the one just mentioned, one or more cylinders will fail to fire. The order in which the wires are connected may be ascertained by removing the plugs from the cylinder and laying them on the metal of the engine so that the spark may be seen to pass between their points as the engine is cranked. The crank should be turned until a spark passes in the plug which was inserted in cylinder number one next to the radiator. The next plug to re-



ceive a spark should be the one which was in cylinder number two, the next one should have been in cylinder number four and the last one in cylinder number three.

With the vibrators properly adjusted, if any particular cylinder fails or seems to develop only a weak action, change the position of the coil unit to determine if the fault is actually in the unit. The first symptom of a defective unit is the buzzing of the vibrator with no spark at the plug. Remember that a loose wire connection, faulty spark plug, or worn commutator may cause irregularity in the running of the engine. These are points that should be considered before laying the blame on the coil.

While examining the coil the following points should be looked for: First see that the contact points on the vibrators are not worn, dirty, stocking or pitted. If any of these faults are found the points should be cleaned by drawing a piece of fine emery cloth between them, first with the emery facing toward one point and then with it facing the other. The coil or coil box may have become wet, which will allow a short circuit, and it is also possible that some of the connections inside of the coil box have become loose.

If misfiring occurs when running at high speed, inspect the commutator. The surface of the circle around which the roller travels should be clean and smooth so that the roller makes a perfect contact at all points. If the roller fails to make a good contact on any one of the four contact points the corresponding cylinder will not fire. Clean these surfaces if dirty.

In case the fiber, the contact points and the roller of the commutator are badly worn, the most satis-

factory remedy is to replace them with new parts. The spring should be strong enough to cause a firm contact between the roller points if they are worn or dirty.

It is a well known fact that in cold weather even the best grades of lubricating oil will congeal to some extent. If this occurs in the commutator it is very apt to prevent the roller from making perfect contact with the points imbedded in the fibre. This, of course, makes starting difficult as the roller arm spring is not stiff enough to brush away the film of oil which naturally forms over the contact points. To overcome this, as well as any liability of the contact points to rust, use a mixture of twenty-five per cent kerosene with the commutator lubricating oil which will thin it sufficiently to prevent congealing. In starting the car in cold weather it may be noticed that only one or two cylinders will fire for the first minute or so. This indicates that the timer is in the condition described above, and as a consequence, a perfect contact is not being made on each of the four terminals.

While the commutator is being examined see that the roller is free to revolve on its pin and that the roller arm does not stick in one position. If either of these faults is present the parts should be cleaned and oiled and if found necessary the spring tension on the roller arm should be increased. It is also possible that the roller arm or roller sleeve is loose on the forward end of the camshaft and this would indicate play in the key or the nut which holds it in place. The fiber ring on the inside of the timer shell around which the roller passes should be smooth and should have no ridges or depressions. If such condi-

tions are found to be present it will be best to secure a new timer shell and install it.

Should ignition trouble be present while batteries are being used as a source of current, the battery should be examined for low amperage, if of the dry cell type, or for low voltage if of the storage type. Dry cells should show an amperage of at least six for each cell, and in the case of a storage battery, the voltage across the terminals should be equivalent to two each cell of the battery, which in the case of the ordinary three-cell battery would call for a terminal voltage of six.

Dry cells used for ignition should be examined to see that none of their terminals are loose and that there are no broken connectors between the several cells. The terminals of either a dry cell battery or a storage battery should be clean and dry and should not be in such a position that they can touch any metal part of the car or of the battery box. The cardboard cover of a dry cell serves to insulate the zinc casing from any other metal part and this cardboard must be whole and dry. In case the covers are worn, broken or wet they will allow leakage of the current.

#### CARBURETOR TROUBLE

Every possible carburetor trouble must result in making the mixture either too rich or too lean; that is, it must make the mixture such that there is either too little gasoline or too much gasoline in proportion to the amount of air being supplied. It will first be necessary to decide whether the mixture is rich or lean.

A mixture that is too thin and which requires more gasoline to make it right is of course improved by

turning the dash adjustment to the left, thus opening the needle valve in the carburetor. A thin mixture will cause hard starting and loss of power. It will also cause spitting and a popping noise in the carburetor, and while the engine is running, it will probably result in missing explosions. Should the engine be in operation with the exhaust manifold removed, a lean mixture will cause the exhaust flame to be yellow in color. A correct mixture produces an exhaust flame which is blue or purple.

Too rich a mixture will result in a dense black smoke from the exhaust and the engine will become greatly overheated. It will also be noted that the engine loses power and that there is a peculiar form of missing which recurs at regular intervals and keeps time with the running of the engine. This missing might be described as a galloping action, and seems to result in the omission of one power stroke in every second cycle of the engine. In case the mixture is too rich the exhaust will have a strong pungent odor and there will probably be considerable flooding from the carburetor after the engine stops. Should the engine be run with the exhaust manifold removed, the flame caused by rich mixture will be red in color.

In order to correct a wrong mixture which is due to improper position of the dash adjustment it will only be necessary to set this adjustment right and to make this right setting the engine will have to be started. Starting the engine may be facilitated by choking the carburetor, which means to shut off almost all of the incoming air by means of the small butterfly valve placed at the carburetor intake and operated from in front of the radiator. Starting may sometimes be made easier by flooding the carburetor in case the

instrument is provided with a small pin above the float bowl which, when depressed, pushes the float down and opens the float valve. Priming the cylinders as a remedy for hard starting has already been mentioned and consists in putting about a spoonful of liquid gasoline into one or more of the cylinders after the spark plugs have been removed.

If the carburetor has been taken apart, or if it is known to be badly out of adjustment, see that the level of the gasoline in the nozzle is about one-sixteenth of an inch below the nozzle opening. Next close the needle valve dash adjustment tight, then open it from three-fourths to one and one-fourth full turns. Retard the spark lever and open the throttle about one quarter of the way. Turn on the switch and start the engine. Slowly close the throttle until the engine seems almost ready to stop. Then open or close the dash adjustment until the engine runs faster again without opening the throttle. Close the throttle a little more and keep turning the needle valve one way or the other until the engine runs as slow as it will run without stopping and with the throttle as far closed as possible. Set the throttle stops, and the carburetor is adjusted for low engine speeds.

Now advance the spark two-thirds of the way and open the throttle wide for a few seconds to see if the engine speeds up. Do not keep the throttle open and allow the engine to run fast or race but for a few seconds, just long enough to notice the action. If there is no spitting noise, close the needle valve a part of a turn.

If the engine runs too fast with the throttle full retarded, unscrew the carburetor throttle lever adjusting screw until the engine idles at a suitable speed.

If the engine chokes and stops when the throttle is fully retarded the adjusting screw should be screwed in until it strikes the boss, thus preventing the throttle from closing too far. When proper adjustment has been made tighten the lock-screw so that the adjustment will not be disturbed.

There are a number of carburetor troubles which produce a thin mixture and yet are not due to any fault in the carburetor adjustment. One of these troubles is that the shut-off valve underneath the fuel tank may be partly closed or that the fuel line may be clogged with dirt or impurities.

Similar trouble may be caused in case the fuel line is bent or cracked and a stoppage of the fuel flow may be caused either by an air lock or a water lock. An air lock is caused by allowing the fuel line to run upward and then sharply downward so that air may collect in the pocket thus formed. A water lock may be caused by allowing the fuel line to turn sharply downward and then upward again, this condition allowing water to remain in the pocket formed and the water being heavier than gasoline prevents a flow of fuel.

The presence of water in the carburetor or gasoline tank, even in small amounts, will prevent easy starting, and the engine will misfire and stop. As water is heavier than gasoline, it settles to the bottom of the tank, and into the sediment bulb along with other foreign matter. As it is difficult to get gasoline absolutely free from impurities, especially water, it is advisable to frequently drain the sediment bulb under the gasoline tank. During cold weather the water, which accumulates in the sediment bulb, is likely to freeze and prevent the flow of gasoline through the pipe lead-

ing to the carburetor. Should anything of this kind happen it is possible to open the gasoline line by wrapping a cloth around the sediment bulb and keeping it saturated with hot water for a short time. Then the water should be drained off. In event the water gets down into the carburetor and freezes, the same treatment may be applied.

The spraying nozzle of the carburetor has a very small opening and a minute particle of grit or other foreign matter will clog up the orifice. The engine will then begin to misfire and slow down as soon as it has attained any considerable speed. This is accounted for by the fact that at high speeds the increased suction will draw the particles of dust or dirt into the nozzle. By opening the needle valve half a turn and giving the throttle lever two or three quick pulls with the engine running, the dirt or sediment will often be drawn through, when the needle may be turned back to its original place. If this does not accomplish the purpose the carburetor should be drained. Be careful not to screw the needle valve down too tight or you will groove the needle and valve seat.

Any leakage of air into the inlet manifold or combustion chamber will result in a weak mixture. Such an air leak may occur around the spark plugs, around the joints in the inlet manifold or around the carburetor flanges. The gaskets at these last two points should be tightly secured.

In case of an old car an air leak may occur around loose throttle bearings, and the remedy is to bore out the hole and use a larger throttle pivot. A reduction of the fuel flow may result in case the vent hole through the fuel tank cap has become closed, as it will

be realized that gasoline cannot flow out of the tank unless air can flow in.

There is another class of troubles which results in a rich mixture, but these are not due to wrong carburetor adjustment. The float or the float valve may be binding, or some of the float valve parts may have become loose. The float itself may have become soaked with gasoline, and this condition may be remedied by thoroughly drying the float in a warm room and then covering it with shellac. Too rich a mixture may be caused by the needle valve being worn in such a way that a shoulder is formed, and the most satisfactory remedy is to use a new valve.

The flow of gasoline entering the carburetor through the feed pipe is automatically regulated by the float-needle raising and lowering in its seat. Should any particle of dirt become lodged on the seat, which prevents the needle from closing, the gasoline will overflow in the bowl of the carburetor and leak out upon the ground.



## CHAPTER VIII

### ELECTRIC STARTING AND LIGHTING

On the older models of Ford cars the lighting system is made up of three oil lamps and two acetylene gas head lamps. The acetylene lamps are supplied with gas from a generator carried on the left hand running board of the car. In the bottom of this gen-



Figure 53.—Parts of the Acetylene Gas Generator.

erator is a basket which should be filled three-fourths full of lump carbide, and in the upper part of the generator is a tank which should be filled with water. A valve is provided which allows the water to drip onto the carbide and the reaction forms acetylene gas almost immediately. This gas is conducted through tubes and burns in the lamps at jets especially constructed for the use of this illuminant.

Should the water valve become clogged the top part of the generator should be removed and the valve stem unscrewed. Blowing through this valve opening will then clear the obstruction. If the lights flicker it

indicates that water has collected in the tubing, and the pipes should be disconnected from the lamps and from the generator, after which the water may be

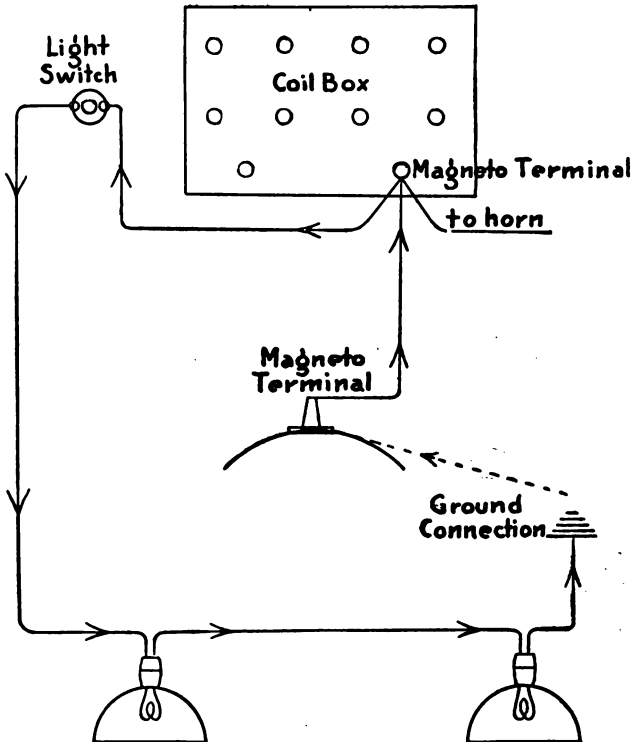

Figure 56.—Wiring of Ignition and Lighting System.

blown out. All of the parts of the old style acetylene generator are shown in Figure 55.

On Ford cars, which were originally equipped with

acetylene lighting, it is not advisable to use electric lights operated from the magneto, because the magneto, as made at that time, was designed only to furnish current to make sparks for igniting the gas in



Figure 57.—Ignition and Lighting Parts on the Car.

the engine cylinders. Under ordinary conditions the magneto would furnish an excessive current; however, all of the electricity generated by the old style magneto is needed when the car is being operated under

extraordinary conditions. For example, when the engine is running slowly and pulling hard all of the current furnished by the magneto is needed for ignition.

On the newer models of Ford cars electric lighting operated from the magneto is furnished as standard equipment. The path taken by the magneto current in the new Ford lighting system is shown in Figure 56. Current starts from the magneto terminal about

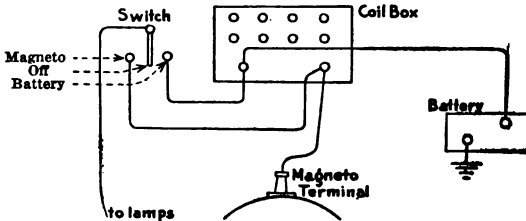

Figure 58.—Using Battery with Ford Ignition and Lighting System.

the flywheel, and flows through the wire to the magneto terminal on the coil box. Another wire is attached to this coil box terminal and leads to the lighting switch on the dash. When the switch is closed the current flows to the right hand head lamp and passes through the filament in the lamp bulb. After passing through the right hand lamp the current flows through a wire which connects the two lamps and then passes through the filament of the bulb in the left hand lamp. From the left hand lamp a connection is made with the metal of the car and current flows through the metal back to the end of the magneto winding, which is also attached to metal. The appearance of the lighting system on the car is shown in Figure 57.

Batteries are not provided on the Ford car as standard equipment, and it is, therefore, impossible to light the head lamps unless the engine is running, and causing the magneto to generate current. In case a storage battery is used as an auxiliary source of ignition current, the head lamps may also be operated from this battery when the magneto is not generating current by replacing the standard lighting switch with a double throw switch, and rearranging the connections so that they are made, as shown in Figure 58.

#### ELECTRIC LIGHTING ATTACHMENTS

Ford cars of any model may be equipped with a system of electric lighting or electric lighting and starting which is attached to the car after it is built. Ford systems are made by a number of electrical manufacturers and comprise many different types of equipment. The principles embodied in all of the different makes are similar regardless of the method of application selected.

Any electric starting and lighting system must first provide a flow of electric current and this flow is secured from a dynamo which is driven from the engine by means of chains, belts or gears.

Because of the fact that the engine cannot always be running when current is required for lighting, and will never be running when current is required for starting, it is necessary to provide means for storing some of the surplus energy made by the dynamo while it is running. This energy is retained and held ready for use by a storage battery which is a chemical device suitable for absorbing electrical energy and for releasing this power when it is needed. The dynamo, which is the primary source of current, and the bat-

tery which forms a reservoir of power are the fundamental parts of the whole system. It is necessary to provide means for controlling the current output of the dynamo, means for allowing the driver to light the lamps or to cause the starter to work, and to provide the parts which consume current. The parts which consume the electrical energy are the lamps and the engine starting motor.

The dynamo consists of a revolving element called the armature and this armature is carried in such a position that it turns within a space which is almost completely surrounded by electromagnets. At one end of the dynamo armature is a ring composed of a large number of bars or strips of copper and in contact with this ring which is called the commutator, are brushes, usually made from carbon, which collect the electric current from the commutator as fast as it is produced in the wires which are a part of the armature proper. From the brushes, connections lead to the terminals of the storage battery so that the energy of the electric current can act on the battery and store the power for future use. Attached to the battery terminals are wires which lead to the lamps and the starting motor and between these units are placed switches which give the driver control of the whole electrical system. The dynamo and battery connections are shown in Figure 59.

Before going further into the workings of the electrical system it will be well to explain the meaning of the terms and words which it will be necessary to use in telling of the workings of these parts. Electricity cannot be measured in inches, pounds or gallons as can substances. Electricity can only be measured by its various effects on materials and parts.

The two principal qualities of electricity which will be most often mentioned are its pressure, which is expressed in a unit called volt; and its quantity expressed in amperes.

The voltage of a current will depend on the construction of the parts used in the circuit and on the speed at which the dynamo is revolving. The amperage will depend on the voltage, or pressure, present and on the resistance to the flow of current which is

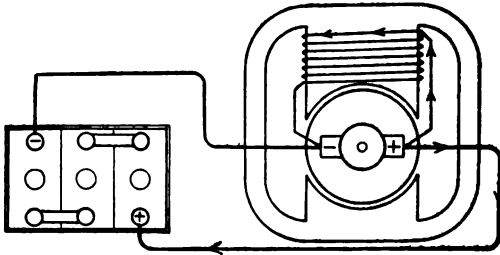

Figure 59.—Lighting Dynamo and Battery Connections.

dependent on the wires or other conductors through which the electricity is passing. The resistance also depends on the length of the conductor through which the current must flow, a long conductor having a resistance which becomes great as its length increases. The conductors used in automobile starting and lighting systems are made principally from copper, iron and brass.

It should be remembered that voltage measures only the pressure of the electricity and that it corresponds to pounds per square inch in measuring water pressure. Voltage does not measure the rate of flow or the quantity of current flowing through a conductor. Amperage measures only the quantity or rate of flow.

Amperage corresponds to gallons per minute flow in measuring water. When the amperage of a current is known the total quantity of electricity may be determined provided the time during which it flows is known. .

In order to make the action of the electrical system more clearly understood, the dynamo may be compared to a water pump and the flow of current from the dynamo may be compared to the flow of water from the pump. As the speed of the water pump increases the pressure of the water will increase. Likewise, as the dynamo speed increases, the pressure, or voltage, of the electricity will be increased. In either case, as the pressure increases, the flow of water or electricity will be increased.

An uncontrolled increase in voltage and amperage such as would be caused by an increase in car speed and dynamo speed might do damage to the battery and to other parts of the electrical system, and in order to prevent such damage, various methods are employed to limit the flow of current when the dynamo speed increases above a certain point.

Carrying out the comparison between the dynamo and a water system, it will be realized that the water pressure at the pump would have to be greater than the pressure in the tank of water in order for the pump to send water into the tank, and in the same way it is necessary that the voltage at the dynamo be greater than the voltage at the battery in order that current may flow through the battery and thus store electrical energy.

Should the speed of the dynamo fall below a certain point, as it will when the engine runs very slowly or comes to a stop, the dynamo voltage will fall below



the voltage of the battery. With a battery voltage higher than the dynamo voltage, the pressure at the battery will be higher than the pressure at the dynamo and the same thing will happen as would come to pass should the water pressure in a tank become higher than the pressure from a pump connected with the tank; namely, a flow of water from the tank to the pump or a flow of electric current from the battery to the dynamo. Such an action would reverse the normal order of things and the battery would discharge its electrical energy so that none would be left to do useful work in starting the engine or lighting the lamps.

Such a reverse flow of current is prevented by a device called a cut-out which is usually acted upon by the electrical pressure of voltage of the dynamo. The cut-out is a form of switch inserted between the dynamo and battery and this switch is open, so that current flow is prevented, whenever the voltage of the dynamo is below that of the battery. When the dynamo armature commences to revolve, the voltage commences to rise, and just as soon as this voltage in the dynamo reaches a value which is greater than the normal voltage of the battery connected with the system, then the cut-out switch is closed and current flow takes place from the dynamo through the battery so that the battery is charged.

The storage battery is really the center of the whole electrical system because it is connected with each of the other parts. The current generated by the dynamo flows through the battery and in doing so it causes certain chemical changes to take place in the elements of which the battery is composed. This action is called battery charging, and after the action

has gone on for a certain period of time, the elements of the battery are so chemically changed that they contain an amount of energy, or an ability to do useful work, which depends on the power consumed by the dynamo in doing the charging.

After the battery has been charged it is capable of causing a flow of electric current through any con-

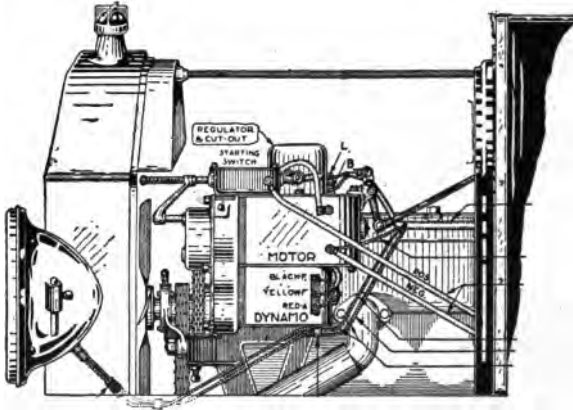

Figure 60.—Lighting Dynamo and Starting Motor on Ford Engine.

ductors which may be attached to its terminals, and after such a flow of current has continued for some time, the elements in the battery return to their original state and the battery is no longer capable of causing a current flow. The battery is then said to be discharged and it will again be necessary to allow the dynamo to act upon it as before. In actual practice on the car, the battery is never allowed to be wholly discharged, but the dynamo does a certain

amount of recharging every time the engine is operated.

The starting system for the engine consists of an electric motor which is attached to the battery by means of heavy wires and a starting switch which may be closed by the driver whenever it is desired to crank the engine. The general construction of the starting motor is similar to that of the dynamo, and in fact the two units are often combined in one mechanism which alternately performs the functions of a dynamo and of a starting motor. The difference between a dynamo and a motor is that the dynamo is used to convert mechanical power into electrical energy and the starting motor converts electrical energy into mechanical power. One method of dynamo and motor application is shown in Figure 60.

#### THE BATTERY

The storage battery is composed of plates made from alloys and compounds of lead, these plates being immersed in a dilute solution of sulphuric acid. A certain number of plates are grouped in two sets, one set being called the negative group and the other the positive group. These groups are placed inside of a jar made from some waterproof and insulating substance such as compounds of rubber or pitch or of glass. When the container is filled with the battery liquid the whole assembly is called one cell. A number of cells connected with each other make up the battery.

*In order to bring the elements of the battery plates into condition so that they are capable of causing a flow of current, it is first necessary to pass current through them. The energy of this current cause*

chemical changes to take place and when these changes are allowed to reverse, the battery discharges and causes a flow of current through any wires connected with it.

The voltage obtained from one cell of a battery does not depend on the size or weight of the plates or on the number of plates used in the cell. Regardless of the size the voltage of one cell will be approximately two, so that a battery composed of three cells will always be a six volt battery, one composed of six cells will be a twelve volt battery, and so on for any number of cells.

In order for the above statement to hold strictly true the individual cells of one battery must be connected in series with each other, that is, the positive of one cell must be connected with the negative terminal of the next cell and the positive of that cell with the negative of the next one. This method of connecting adds the voltage of one cell to the ones connected with it, so that the total voltage of the battery is equal to the number of cells multiplied by two.

The quantity of current that may be secured from a battery when fully charged depends on the size of the plates and on the number used in one cell. The capacity of a battery or of a cell is measured in ampere hours. An ampere hour is the quantity of electric current that will pass through a conductor if a flow of one ampere continues for one hour. An equal quantity would pass were a flow of one-half ampere to continue for two hours, or if a flow of two amperes were to continue for one-half hour. Therefore, a battery rated at one hundred ampere hours will theoretically give a flow of one ampere for one hundred hours or a flow of one hundred amperes for one hour.

amount of recharging every time the engine is operated.

The starting system for the engine consists of an electric motor which is attached to the battery by means of heavy wires and a starting switch which may be closed by the driver whenever it is desired to crank the engine. The general construction of the starting motor is similar to that of the dynamo, and in fact the two units are often combined in one mechanism which alternately performs the functions of a dynamo and of a starting motor. The difference between a dynamo and a motor is that the dynamo is used to convert mechanical power into electrical energy and the starting motor converts electrical energy into mechanical power. One method of dynamo and motor application is shown in Figure 60.

#### THE BATTERY

The storage battery is composed of plates made from alloys and compounds of lead, these plates being immersed in a dilute solution of sulphuric acid. A certain number of plates are grouped in two sets, one set being called the negative group and the other the positive group. These groups are placed inside of a jar made from some waterproof and insulating substance such as compounds of rubber or pitch or of glass. When the container is filled with the battery liquid the whole assembly is called one cell. A number of cells connected with each other make up the battery.

In order to bring the elements of the battery plates into condition so that they are capable of causing a flow of current, it is first necessary to pass current through them. The energy of this current causes

chemical changes to take place and when these changes are allowed to reverse, the battery discharges and causes a flow of current through any wires connected with it.

The voltage obtained from one cell of a battery does not depend on the size or weight of the plates or on the number of plates used in the cell. Regardless of the size the voltage of one cell will be approximately two, so that a battery composed of three cells will always be a six volt battery, one composed of six cells will be a twelve volt battery, and so on for any number of cells.

In order for the above statement to hold strictly true the individual cells of one battery must be connected in series with each other, that is, the positive of one cell must be connected with the negative terminal of the next cell and the positive of that cell with the negative of the next one. This method of connecting adds the voltage of one cell to the ones connected with it, so that the total voltage of the battery is equal to the number of cells multiplied by two.

The quantity of current that may be secured from a battery when fully charged depends on the size of the plates and on the number used in one cell. The capacity of a battery or of a cell is measured in ampere hours. An ampere hour is the quantity of electric current that will pass through a conductor if a flow of one ampere continues for one hour. An equal quantity would pass were a flow of one-half ampere to continue for two hours, or if a flow of two amperes were to continue for one-half hour. Therefore, a battery rated at one hundred ampere hours will theoretically give a flow of one ampere for one hundred hours, or a flow of one hundred amperes for one hour.

The efficiency of a battery is much greater at low rates of discharge than at high rates. The above mentioned battery would give a flow of one ampere for practically one hundred hours, but would only give a flow of one hundred amperes for a few minutes, because the violence of the action causes changes that prevent further discharge until the battery has been given time to recuperate to some extent.

The rate of discharge from any battery should not exceed in amperes one-eighth of the total ampere-hour capacity of the battery. Care should be exercised to prevent the battery from becoming discharged to such a point that the voltage falls much below a total of two for each cell, because when the discharge has progressed beyond this point, the plates will change in such a way that it becomes very hard to restore them to their charged condition regardless of the amount of current flow given by the dynamo.

The mixture of water and sulphuric acid which is placed in the cell with the plates is called the battery electrolyte. When the battery is in a fully charged state almost all of the acid has been driven out from the material composing the plates and is in solution with the water. As the battery discharges, the acid leaves the water and enters the plates so that the strength of the solution or electrolyte becomes less and less as the discharge progresses. The condition of charge of a battery may be very closely gauged by measuring the acid strength of the electrolyte, and this is done by measuring the specific gravity of the solution with a hydrometer, as shown in Figure 61.

The hydrometer consists of a glass tube weighted at its lower end and provided with a graduated scale toward the upper end. This tube is inserted into the

electrolyte and the depth to which it sinks in the liquid as measured on the graduated scale indicates the condition of charge or discharge of the battery. Sulphuric acid is nearly twice as heavy as water for a given volume. The weighted tube will not sink so

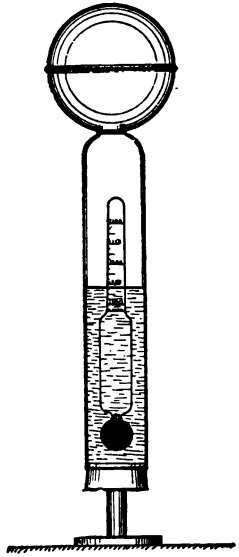

Figure 61.—Battery Testing Hydrometer.

deep into a heavy liquid as into a light one, and it will therefore not sink so deep into the electrolyte when it contains a large percentage of acid as when the proportion of acid has been reduced. The scale on the tube is graduated from 1.100 to 1.300, the 1.100 mark being near the top and the 1.300 being near the lower part. If the hydrometer sinks down until the



1.100 point on the scale is at the surface of the liquid surrounding the tube, it indicates that the electrolyte has become nearly pure water and that the battery is discharged. Should the 1.300 point on the scale remain near the surface of the liquid, it indicates that the solution is strong in acid and that the battery is well charged. A reading of 1.200, which is midway between the other two, would show that the battery is about half charged.

The hydrometer itself is carried inside of another tube of larger diameter and this tube, called the hydrometer syringe, is provided with a bulb at its upper end and with a rubber-tipped nozzle at its lower end. When a battery or a cell is to be tested for its specific gravity the rubber bulb is squeezed with the hand and most of the air expelled. With the bulb held in this way the rubber nozzle is lowered through a hole in the top of the cell until the opening is below the surface of the liquid, after which the bulb is released until a quantity of electrolyte sufficient to float the hydrometer is drawn up into the syringe. The point on the scale which is at the surface of the liquid is then noted and this is the specific gravity of the cell being tested.

With a battery in good condition and well charged the specific gravity will remain between 1.200 and 1.300 and should preferably remain around 1.250. Should the gravity fall to 1.150 or below, the cell is in danger of becoming permanently damaged and the electrical system should be given attention.

It is very necessary that the level of the electrolyte in all of the cells of a battery be kept above the tops of the plates, and this is done by adding distilled water at regular intervals. This will require the addi-

tion of water about every week or ten days in summer and from every two weeks to once a month in cold weather. Acid or electrolyte should never be added to a cell under ordinary conditions in order to bring the gravity to the desired point because there will be just as much acid in the cell as there was originally and the addition of more will only serve to destroy the plates. The water will evaporate from the electrolyte, making it necessary to add more to replace this evaporation, but the acid will remain unless spilled or lost through leakage from a broken jar in a cell. If the gravity becomes low it does not indicate that acid should be added but that the cell or the battery needs more charging.

The efficiency of a cold battery is much lower than that of a warm battery and in cold weather the battery requires either more charging or else less discharging to keep it in good condition. This condition is made worse because of the fact that the dynamo does not normally give so great an output during cold weather as in warm. Lamps should be economically used in cold weather, and if convenient, bulbs of lower candle-power should be substituted. It will be advisable to start the engine by hand on cold mornings or at least to prime the cylinders so that less cranking is required.

#### LAMPS AND WIRING

The same size and type of lamp bulbs should always be used in making replacements as were originally supplied with the equipment. Bulbs of larger size will impose a load on the system for which it may not have been designed and bulbs of either larger or smaller size than those originally fitted may serve to throw the lamps out of focus. Bulb bases in common

use are of two principal types, one for use with what is called a two-wire system and the other for use with a one-wire or ground-return system. The two-wire base has two small contact points which touch two spring contacts in the socket into which the bulb fastens. One-wire bases have but one contact point

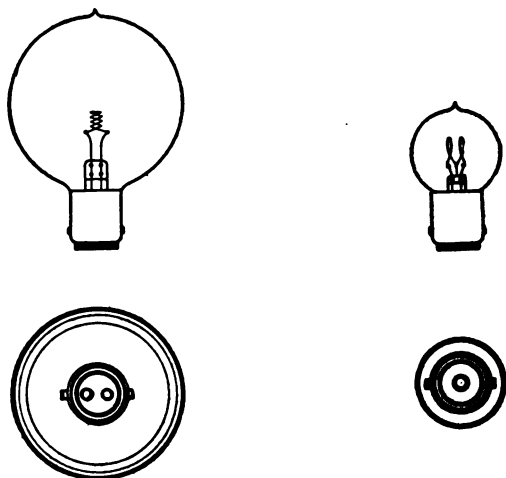

Figure 62.—Double and Single Contact Lamp Bases.

and this is in the center of the base. A two-wire bulb will not work in a one-wire socket, neither will a one-wire bulb work in a two-wire socket. The two bases are shown in Figure 62.

Should the surfaces of the reflectors in the lamps become dirty or tarnished they may be cleaned by blowing the dust from the parts, and if this does not do the work, it is permissible to wash them with a slow flowing stream of clean cold water. The reflectors

should then be allowed to dry by the action of the air and should not be wiped, because every time they are touched, small scratches are left and their efficiency is impaired. If the surface which is silvered has become very dull it may be cleaned with alcohol used on a clean soft chamois skin held in such a position that the skin is free from wrinkles. The reflectors should be wiped off with a rotary motion and working from back to front or by strokes starting from the bulb and ending near the outer edge. Polishing may be done with the chamois skin moistened with alcohol and then covered with a small quantity of jeweler's rouge. This will remove any dirt or tarnish and the polishing may be completed with a dry chamois skin and more rouge.

In order to get the best effect of the lamps in lighting the road surface they must be properly focused. This is done by changing the position of the bulb with reference to the reflector and the exact method employed depends on the type of lamp applied to the car. The focusing screw may be found near the upper edge of the reflector and behind the front glass or may be located behind the reflector and attached to the socket into which the bulb fits. Several methods of focusing are shown in Figure 63.

The lamps are focused by disconnecting the wires from one of them and working with the one remaining until it is properly set, then removing the wires from the one already focused and reattaching them to the first one. The car must be taken to a place where there is very little if any outside light. A large dark room, or the open road on a dark night, make the best places to do this work. The adjustment should be moved until the light cast on the road is clear and

free from dark spots or rings and even after this effect is secured it will be best to make a trial under driving conditions before finally deciding that the adjustment is correct. After the bulbs have been

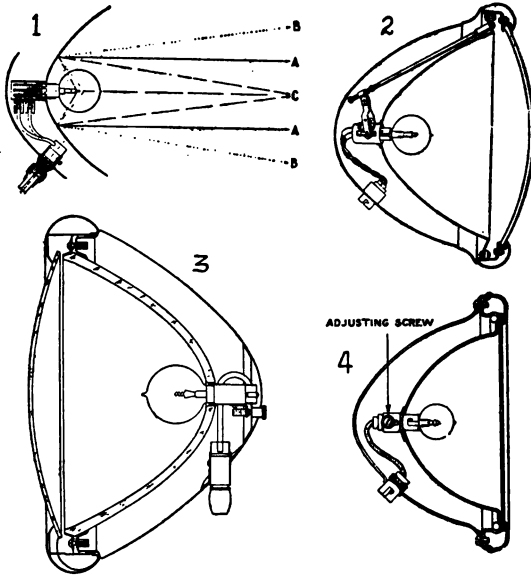

Figure 63.—Focusing Adjustments: 1—Correct and Incorrect Paths for Light Rays (A, Correct; B or C, Incorrect). 2—Adjusting Screw Above Reflector. 3—Adjustment in Lamp Housing. 4—Adjustment in Socket.

properly focused the lamps may be moved on their brackets or the brackets may be moved until the beam of light from each one strikes the road at the point desired by the driver.

Two distinct systems of wiring are in use, one called the two-wire method and the other one-wire or ground-

return method. With the two-wire method there are two complete conductors between battery and the lamps and other electrical units on the car. One of these wires connects the units with the positive side of the battery, while the other carries the negative side of the circuits. In the one-wire system one side, either positive or negative, of the battery is connected with the frame and metal work of the car and the metal is thus allowed to act in place of one of the wires used in the two-wire system. All of the other electrical units included in the one-wire connections are then connected with the metal of the car so that this side of the circuit is completed. The remaining side of the battery is connected through the wiring and switches with the lamps, dynamo, starting motor, or other electrical parts.

Because of the possibility of some of the insulation becoming stripped from the wires and causing a short circuit with the one-wire system, fuses are generally inserted between the battery and the various parts comprising the system. A fuse consists of a short length of wire made from metal which will carry the normal amperage supposed to flow through its circuit but which will become heated and melt apart when the amperage exceeds this amount to any great extent. This wire is generally enclosed in a tube of fibre or glass so that the heat generated just before melting will not set fire to any gasoline vapor that might be present around the car.

Fuses are rated according to the amperage or current flow that they are designed to carry safely. It is not necessary to pay any attention to the voltage of the system in selecting fuses. The proper size to use will depend on the type of system employed and on the

size and current consumption of the current-consuming devices such as lamps, horns, etc. For a six-volt equipment it will be safe to use the following size fuse: Head lamps, 15 amperes; side lamps alone, 5 to 10 amperes; tail and dash lamps, 5 amperes; all lamps, 10 amperes; horn, 15 amperes; charging circuits, 20 to 40 amperes.

A fuse must never be replaced with a piece of wire or with another fuse of larger capacity, because this will remove all protection for the battery and it may easily become ruined should a short circuit occur.

#### TROUBLE LOCATION

The most commonly encountered form of electric trouble in starting and lighting systems is that known as a short circuit. This is a connection between two wires or conductors, one positive and the other negative, such that the current flow may take place from the battery or dynamo and find a complete return path back to the source without passing through the current-consuming devices or without doing the work which it would do were the short circuit not present. This simply means that the current finds a shorter path than the one which it should take.

Should the current carrying conductor of either positive or negative polarity come into direct contact with the frame or metal work of the car when the metal work forms a part of the electrical system, as is the case with the one-wire system, there is a form of short circuit called a ground.

In case some conductor becomes broken or where ever there is a conducting path which is not complete from the battery or dynamo to the current-consuming device and then back to the source, the trouble

called an open circuit. There will be no flow or current through any part of a circuit that is open at any point.

High resistance in any part of the system will lead to trouble and may be the result of poorly made or dirty contacts in which the current carrying surfaces are not brought tightly together. This so reduces the area of the conductors that the flow of current is

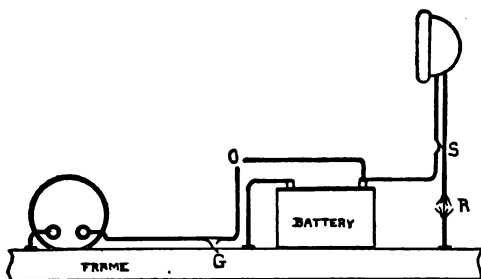

Figure 64.—Wiring Troubles: *G*, Ground; *O*, Open Circuit; *R*, High Resistance; *S*, Short Circuit.

greatly hindered and the electricity is unable to do its proper work. Wires that are loose or that are partly broken will cause high resistance and dirty, pitted or corroded parts at the wire terminals or in any other part of the apparatus will cause similar difficulties. The troubles just mentioned are shown in Figure 64.

Because of the fact that almost any trouble that may come to the electrical equipment will cause some change in current flow or pressure, the subject of indicating instruments is closely allied with that of trouble location.



Ammeters are provided with a pointer or hand which moves from side to side with increase or decrease of flow through the circuit in which the instrument is placed. The pointer moves across a scale graduated in amperes or fractions and multiples of amperes and having a zero point at or near the center of the graduations. The pointer will move one way from this zero point with flow of current in one direction; for instance, into the battery, and will move in the opposite direction from the zero point when current flows in the opposite direction, as would be the case during battery discharge. This type of instrument is known as a "zero center" ammeter. If the meter were built in such a way that the hand stood at one side of the scale when at zero, it would only measure the flow of current in one direction and would not be so well suited for attachment on the car.

An ammeter when placed on a car should be so connected that it will measure all of the current flowing into the battery from the dynamo and so that it will measure all current leaving the battery except that used for starting. An ammeter sufficiently great in capacity to measure the large flow during the cranking operation would have a scale too coarsely divided to measure the small currents used for charging and lighting. It is therefore necessary to find a wire of the car that carries all of the charging current and all of the lighting and other accessories' current, but none of the starting current. This may usually be done by following either one of the large battery cables until a smaller line branches from this cable. The ammeter may then be attached in this smaller line and just as close to the large cable as possible. Provided the wire selected carries all of the lighting

and charging current and none of the starting current, the ammeter will then indicate the net charge and discharge other than for starting.

Should the charging wires and the lighting wires be connected to the large cables from the battery at different points along these heavy cables, it will not be possible to attach an ammeter to show both charge and discharge. This will also be the case with a great many combined motor and dynamo systems in which no line can be selected that carries both charging and lighting currents and that does not carry the starting current. It will often be found possible to attach an ammeter so that it will show charge into the battery, but no discharge for the lamps and other current-consuming devices. It will also be possible to attach an ammeter to one side of a separate dynamo so that the dynamo output will be indicated; this method, however, is of comparatively little value because it is the current entering the battery that is more essential than that furnished by the dynamo. In the absence of special directions for attaching an ammeter it will be necessary to follow the wiring as described or else to examine a wiring diagram of the car or system in question until a line is found that does not carry the starting current but that does carry the currents whose value it is desired to measure.

With the ammeter connected, some lamps should be turned on and the direction in which the needle moves should be noted. If the scale is marked "Charge" and "Discharge," the needle should move toward "Discharge," and if it does not do so, the wires should be removed from the ammeter terminals and interchanged with each other. In case the face of the meter is not marked the connections should

in such a way that the needle will swing to the right of zero for charge and to the left for discharge.

*Indicating Instrument Faults.*—Because of the fact that ammeters, voltmeters, etc., are primarily designed to tell what is happening and to aid in locating trouble, it should not be assumed that these units themselves are free from error. Outside of trouble caused by open, short or grounded circuits and circuits of high resistance in the wiring and terminal connections of these instruments, they may develop trouble within their mechanism. Should an ammeter be subjected to a current much greater than it is designed to carry, such as would be the case were an ordinary instrument connected in the starting circuit, the current-carrying coils would be burned out and the meter would have to be rebuilt before further use could be made of it.

When an ammeter or voltmeter is in proper working order, the hand should remain at zero with one or both of the wires removed from its terminals. Should there be an error at this time, the number of amperes or volts should be noted and allowed for in future readings. The hand should move quickly from point to point and should come to rest within a reasonable time.

In case of failure to light, the bulbs themselves should be examined to make sure that they are not broken and that the filaments are not burned out. Should the lamp have been fitted with bulbs designed for a voltage lower than that used on the car, the filament will be burned out, while bulbs designed for a higher voltage than that used will burn dimly or may not light at all.

It is quite possible for dirt, loose wire strands or faulty construction to cause an accidental short circuit in the bulb base or in the socket into which the

base fits. Such a fault will probably result in such a heavy flow of current at the defective point that heating will result, and at the same time all the other lamps on that circuit or line will burn dimly or not at all. It may be found that the small contact points on the bottom of the bulb base do not make contact with the plungers or springs in the socket.

The springs may be bent up slightly or the contact points may be extended by the addition of a drop of solder to each. If the socket contains spring plungers, they should be pressed down and examined for binding or dirt that will cause sticking when the bulb base is pressed home. If the plungers can be pressed down and then remain down, it indicates that the springs have become broken or are binding, and a new socket is the most satisfactory remedy. The interior of the bulb sockets should be kept free from dirt and foreign matter of all kinds, because the result may be either a short circuit or an open circuit for that particular lamp. It is customary to provide the lamps with connectors into which the wires fasten and which complete the circuit by means of plungers or pins that fit into holes in a second part of the connector. The same remarks respecting dirt and poor connections apply to these outside connectors as to the bulb sockets. Should the lamps flicker and occasionally go out altogether, the wiring at the sockets and at the connectors should be examined for loose strands. In case a part of the copper is found exposed, it should be wrapped with insulating tape to prevent a repetition of the trouble caused by the movement and jarring of the car while in motion.

In case the candle power of the lamps has been increased, or in case additional lamps or other accesso-

ries have been added to any of the circuits, it is quite possible that the wire originally used may be too small for the added load. Lamp circuits should be made with wire not smaller than No. 14 gauge, and 12 gauge will be safer in case of any added load. Wires of opposite polarity should not be run so close together that they touch unless they are bound together with tape or fasteners, because of the chafing that will result. In case it is necessary to run lines through places where they will become wet or oily, the wiring should be enclosed in metal conduits or by circular loom, and the openings through which the wires enter and leave the protecting coverings should be tightly taped.

A large number of systems include busbars, junction blocks or boxes and distribution panels at the terminal posts of which several lines meet and are connected together. These points of connection may develop short circuits between the several cables of different circuits, or may contain accidental grounds on the metal work of the car. Loose strands of wire should be carefully guarded against, and all such wire ends should be fitted with metallic terminal pieces that hold all the wire strands by means of the solder used in making the attachment. It is often found that dirt, oil or moisture enters these connection boxes through the wire openings, and in case the junctions are located at points exposed to such trouble, it will be well to tape each line where it enters the enclosed portion of the junction.

Should the lamps flicker or go out entirely, it is possible that the trouble will be found in the lighting switches. These switches are simple in construction and their action may be understood in each case by

an examination. The contacts should be examined to make sure that they close their respective circuits and to make sure that the leaves are not bent or binding and that the surfaces are clean and bright. The moving parts of the switch may have become loose so that they make only an intermittent connection while the car is in motion, and all of the internal parts should be moved by hand to determine whether this trouble is present. The terminal studs and nuts should be watched for looseness or breakage, either external or internal, and in case of any doubt as to the proper connections being made, a wiring diagram for the system being used should be consulted.

Any failure of the dynamo, cut-out, regulating device or charging wiring will result in the specific gravity of the battery electrolyte becoming abnormally low, and in the voltage of the battery falling below two for each cell. As far as the wiring is concerned, the same advice as that given for the lighting circuits may be applied to this case. Other troubles may come from faulty condition of the dynamo brushes, commutator, armature or fields, or from faults in the cut-out and regulator.

With the brushes exposed, their holders should be examined to see that the pivoted arms are free to swing back and forth, and that sliding brushes do not bind or wedge in any position. Such binding of the brush itself may be remedied by carefully dressing the sides with a fine file. Attached to each brush or to the brush holder is a short length of flexible wire called the brush pigtail. These small wires must not be broken and their connections must be clean and tight at each end.

Either the brush itself or else the brush hol

held by a coiled or flat spring so that the brush bears on the commutator surface with a tension just sufficient to cause the brush end to make good contact at all armature speeds.

These brush springs should not be bent, loose, broken or binding, and should have sufficient tension to cause a good firm connection to be maintained, but should not be set up so tight that there is danger of the brush cutting into the commutator surface.

The brushes should be replaced with new ones when worn down nearly to the holder or spring, and in making such a replacement the safest method is to secure the new brushes from the makers of the car or the makers of the electrical equipment. As a general rule it may be said that none but carbon or carbon composition brushes should be used, because of the fact that brushes made from copper or copper alloys tend to cut into the commutator surface and cause serious damage and rapid wearing. Even with carbon brushes in use, care must be exercised to see that the material is very fine and of smooth grain. Brushes that are light gray in color and that show a granular or rough surface are not safe to use.

Should the brushes be found in good condition, the commutator should be examined next. Its surface should be very smooth and should preferably have a glazed appearance and a dark brown color. In case the surface of the segments is found to be dirty, scratched, rough or pitted, it may be dressed with fine sandpaper by following the method described in the chapter on dynamos. Excessive sparking will cause burning and pitting of the commutator surface, and this sparking will usually be found to result from the use of brushes of improper material or from the

fact that the brushes do not make good contact with the commutator.

The segments forming the commutator should be examined to see that none of them are projecting above the surrounding surfaces and that all are up even with the curve of the commutator. These troubles may be corrected by turning the commutator in a lathe, but if the condition is the result of loose segments or fastenings, the armature should be sent to its makers for repairs. The small wires that connect the segments with the armature coils should be watched to see that they are unbroken and well insulated. Torn or broken insulation may be replaced by taping and then shellacing over the surface of the tape. If the connecting wires are broken they should be fastened in place with hard solder or silver solder.

The starting system consists of the motor, the starting switch, the wiring and the driving parts. Electrical trouble may be present in the motor, switch or wiring, and mechanical trouble may occur in the driving mechanism.

The starting switch contacts may be making poor connection because of wear, looseness or bending, or the contact surfaces may be dirty or pitted from sparking. The terminal connections of the large cables on the starting switch should be examined for loose wire strands, accidental grounds or short circuits, and broken or loose fastenings. The wiring is subject to the same troubles as found in the charging or lighting circuits, but because of the heavy conductors and thick insulation used such faults will be of less common occurrence in the starting system than in other parts of the equipment.

The parts of the starter drive system should be kept



clean and any sliding surfaces should be lubricated with heavy oil or by means of grease placed in the cups. This lubrication should be cared for at least every week if trouble is to be avoided. It may be found that drive shafts have become bent through binding or improper use of the starting pedal and in some cases it will be found that gear shifting and

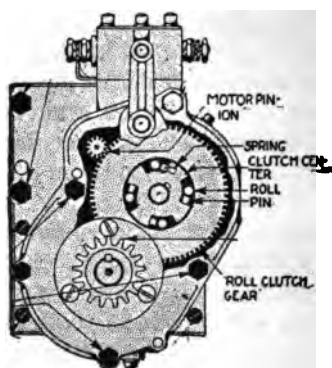

Figure 65.—Driving Parts of Lighting Dynamo and Starting Motor.

switch return springs are not heavy enough for the work to be done, especially on new equipments before the parts have been fully worked in. Over running clutches should be lubricated with vaseline, or rather grease of good quality, and the starting pedal should never be held in the starting position long enough to cause the clutch to be run at high speed. This would surely result in burning the grease and the final result will be a badly damaged or ruined clutch. The driving parts of a dynamo and motor are shown in Figure 65.

## CHAPTER IX

### TRUCK AND TRACTOR ATTACHMENTS

#### TRUCK ATTACHMENTS

The Ford car may be converted into a truck or delivery car having a load capacity of from 1,000 to 3,000 pounds by making certain changes in the running gear, the rear axle and the transmission units. These changes are made by adding to the Ford as originally built, any one of a great many adapters of various forms which have been designed and are marketed by companies making a specialty of this work.

A Ford car thus converted into a truck is able to do the work of two average teams of horses more efficiently and usually at a saving of expense. While the horse-drawn vehicle can hardly make more than twenty miles a day, a truck of this type can easily make from fifty to sixty.

The radius in which a horse and wagon can be used in deliveries is not much more than two miles around the point from which deliveries are to be made, while a motor truck is able to cover an area four times as great. The service given by a truck is superior to horse delivery because it is not so much affected by hot weather or cold or by additional work imposed at holiday and rush seasons; in fact, a truck may be worked for twenty-four hours at a stretch should the necessity arise.

The cost of upkeep on a motor truck is always in proportion to the work being done, whereas the cost

long body so that sufficient loading space is secured. Such a lengthening of the frame may be accomplished in any one of three ways. The first and simplest method adds a long side rail to the Ford frame as originally built and makes this addition at the rear end, as shown in Figure 66. Another method consists of cutting the Ford frame near the center and adding a new length at this point. The third method, and the one most generally adopted, is that in which a new frame is fitted around the outside of the original member, fastening near the dash or even farther forward, and extending outward and back to give the length desired. This added frame is made either from a hot rolled section of channel steel or else from a cold pressed steel piece of the same type as used in pleasure cars and in most standard truck frames.

The addition to the frame is of much greater strength than the Ford frame and serves to strengthen and make the whole new chassis more rigid and better able to stand up in commercial work. This strength is sometimes still further added to by trussing underneath the new side members so that the truss rods serve to support a great part of the load and to distribute it along the frame's length. The new part of the frame may be permanently riveted in place when the new assembly is made or may be bolted to the Ford chassis. The method of riveting, and sometimes the bolted fittings, call for drilling the old frame. In other designs of bolted on parts new holes are required.

In some of the attachments the original springs are used to carry the extra load by adding one or more new leaves to them. In other cases the original springs are dispensed with altogether and new ones are fitted to the new frame extension. The new springs are

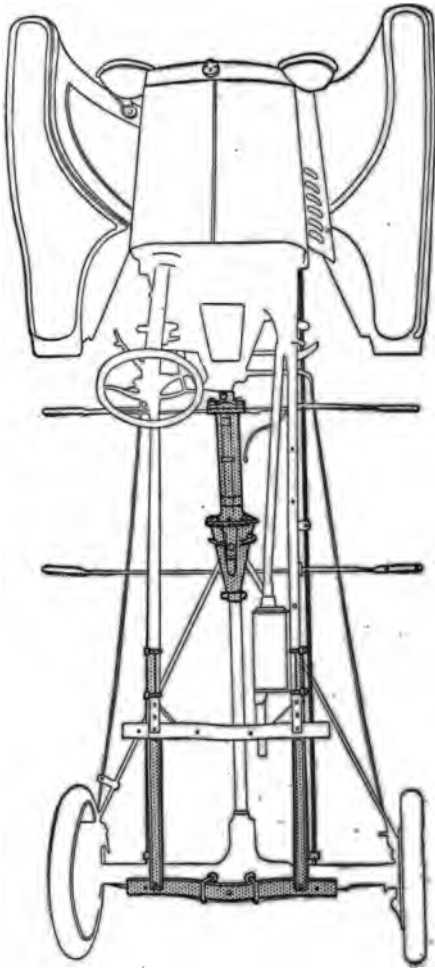

Figure 66.—Extended Ford Frame and Lengthened Shaft.

generally of the semi-elliptic type and run lengthwise of the car, being attached to the frame ahead of and back of the axle. Additional spring suspension may be provided by inserting a cross-member in the frame so that this member is directly above the rear axle. A transverse spring is then attached to this cross-member of the frame so that the outer ends of the spring rest on the axle near its outer end whenever a heavy load is carried. The transverse spring and the semi-elliptic springs on the sides of the frame may also be combined so that the system forms a platform suspension.

The standard Ford wheelbase of one hundred inches is not always of sufficient length to accommodate the desired length of body and, this condition makes it necessary in a majority of the attachments to increase the distance between the front and rear axles so that it becomes anywhere from one hundred to one hundred and fifty inches, depending on the work which it is desired to do. A majority of the adapters provide wheelbases in the neighborhood of one hundred and twenty-five inches. This change in length makes it possible to use bodies which give from six to twelve feet of clear loading space back of the driver's seat.

It is always desirable to carry as great a percentage of the load as possible on the rear axle of the attachment, thus relieving the front end, which remains as in the Ford car, of all additional load. It is generally found that the center of the body is brought directly over the rear axle so that with the load evenly disposed the added weight is all borne by the rear axle. Damage may be easily done to the front end of the combination by placing all of the load ahead of the rear axle. This will place a large part of the strain

on the front axle and tires and under these conditions they cannot stand up. When a truck of this type is loaded it should always be done so that the load is centered over the axle and if it is necessary to have more weight either forward or back then the additional amount should be placed back of the axle.

In case the converted Ford is designed to carry comparatively light loads, the original rear axle gear ratio of 3.63 to 1 is retained, this giving the same road speed as obtained with the Ford touring car. In case the load is to be comparatively heavy, that is, one ton or more, the gear ratio is changed so that it is between 6 to 1 and 9 to 1. This alteration gives increased power but with a corresponding reduction in road speed.

There are five distinct methods of driving the rear road wheels in a Ford attachment. The original beveled gears may be retained, double side chains may be used, either an internal gear or an external gear rear axle may be used or a worm driven unit may be attached. The Ford bevel gear rear axle has already been described and therefore needs no further explanation.

With double side-chain drive, the Ford rear axle is attached to the frame of the converter and is then used in the same way that a jackshaft would be used in a chain-driven truck. Between the engine and the ends of the Ford axle there is of course the bevel gear reduction that has already been incorporated in the axle. By using the chain sprockets of various relative sizes it is possible to increase the gear ratio to almost any desired amount, for instance, using front sprockets of half the size of those placed on the rear wheels would double the gear ratio, making it about  $6\frac{1}{4}$  to

1. The chains used are of the roller type and are generally made of a very generous size, so that they should give but little cause for trouble in service.

The construction of the working parts of the internal gear type of rear axle is shown in Figure 67 and the external appearance of such an axle is shown in Figure 68. The internal gear rear axle consists of a solid load-carrying member generally made of

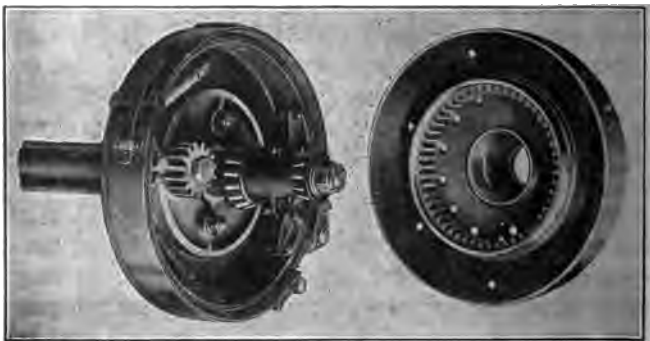

Figure 67.—Operating Parts of Internal Gear Rear Axle.

I-beam section, and attached to this solid part is a jackshaft which may be furnished complete with the attachment or which may be formed by attaching the rear axle of the Ford car to the I-beam cross-piece. In either case a double gear reduction is secured, first at the center of the axle by means of the bevel gears, and second at the hubs of the road wheels by the spur gear and internally toothed drum.

The road wheels are carried on the outer end of the solid part of the axle, and attached to the hub and spokes of the wheels is the internal gear shown in Figure 67. This internal gear is driven by means of

a small spur pinion carried at the outer end of the live part of the axle. The relative size of the internal gear and the spur pinion determines the secondary gear reduction.

The most noticeable feature of the internal gear form of drive is that it provides a solid member for carrying the load and a mechanically separate power transmitting axle attached to the solid member. The power transmitting axle is relieved of all carrying strain and is simply used for propulsion.



Figure 68.—Internal Gear Rear Axle.

The external gear type is somewhat similar in construction to the internal gear, except that the internally toothed drum on the rear wheels is replaced by an external or spur gear.

Some of the Ford attachments make use of a worm-driven type of rear axle, and this construction, of course, dispenses with all of the original rear construction of the Ford car. The worm-driven axle has the advantages of simplicity and strength and gives very complete protection to all moving parts. Excellent results are secured from worm drive because of the comparatively large gear-tooth contact which gives long life. The worm drive is the only system which provides a single reduction and at the same time



1. The chains used are of the roller type and are generally made of a very generous size, so that they should give but little cause for trouble in service.

The construction of the working parts of the internal gear type of rear axle is shown in Figure 67 and the external appearance of such an axle is shown in Figure 68. The internal gear rear axle consists of a solid load-carrying member generally made of

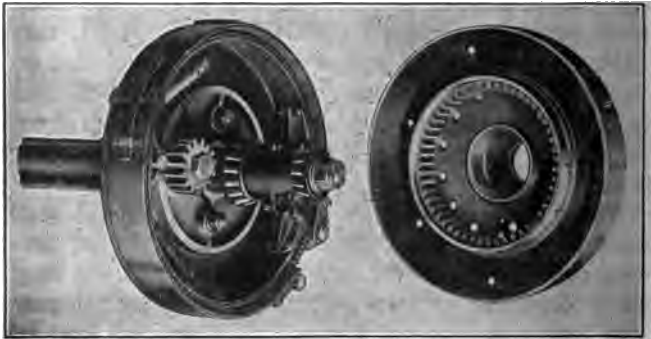

Figure 67.—Operating Parts of Internal Gear Rear Axle.

I-beam section, and attached to this solid part is a jackshaft which may be furnished complete with the attachment or which may be formed by attaching the rear axle of the Ford car to the I-beam cross-piece. In either case a double gear reduction is secured, first at the center of the axle by means of the bevel gears, and second at the hubs of the road wheels by the spur gear and internally toothed drum.

The road wheels are carried on the outer end of the solid part of the axle, and attached to the hub and spokes of the wheels is the internal gear shown in Figure 67. This internal gear is driven by means of

a small spur pinion carried at the outer end of the live part of the axle. The relative size of the internal gear and the spur pinion determines the secondary gear reduction.

The most noticeable feature of the internal gear form of drive is that it provides a solid member for carrying the load and a mechanically separate power transmitting axle attached to the solid member. The power transmitting axle is relieved of all carrying strain and is simply used for propulsion.



Figure 68.—Internal Gear Rear Axle.

The external gear type is somewhat similar in construction to the internal gear, except that the internally toothed drum on the rear wheels is replaced by an external or spur gear.

Some of the Ford attachments make use of a worm-driven type of rear axle, and this construction, of course, dispenses with all of the original rear construction of the Ford car. The worm-driven axle has the advantages of simplicity and strength and gives very complete protection to all moving parts. Excellent results are secured from worm drive because of the comparatively large gear-tooth contact which gives long life. The worm drive is the only system which provides a single reduction and at the same time

allows a great difference between the speed of the engine and that of the road wheels.

There are two distinct methods of carrying the driving power from the rear axle to the frame of the car. With one system there are links or pivoted rods attached at their forward ends to the frame and at the rear to either end of the axle. These are called radius rods and are always used in chain-driven cars, so that the distance of the rear axle from the frame may be altered and the stretch of the chains compensated for.

The other type of drive is through the load-carrying springs and is oftentimes called Hotchkiss drive. The Hotchkiss drive provides a simple and inexpensive method of making the necessary connection and the flexibility of the springs serves in a great measure to relieve the mechanism from shocks. The radius rod drive forms a connection which is entirely separated from the springs and therefore does not impose any additional load on the springs or on their hangers or connections.

The Ford service brake, which consists of a drum and band in the transmission, is generally retained when the car is converted into a commercial vehicle, and this brake provides a very powerful retarding effort because the drum operates at engine speed and between the drum and the road wheels is interposed the total gear reduction by whatever method secured. The power of the service brake is therefore multiplied by the gear reduction. In case the Ford rear axle is used as a jackshaft, the rear axle brake is sometimes used or it may be disconnected and disregarded. When this brake is used it is affected by the gear reduction which affects its leverage. This gear reduction, of

course, depends upon the relative size of the chain sprockets. Practically all truck attachments provide an entirely new brake system attached to the rear hubs of the new truck wheels, and these brakes may either be operated by a foot pedal or by the hand lever which is already on the Ford car.

The simplest and incidentally the least expensive of adapting a Ford car for delivery work is that of attaching an additional set of rear springs which attach directly to the body and which are supported by specially designed housings carrying the wheel hubs so that the weight of the load is carried first through the springs and steel housing directly in the wheel hubs and does not come on the Ford rear axle. This method is illustrated in Figure 69. With such a device the wood wheels with which the Ford is equipped may be replaced with new ones made of steel, which, of course, increases the strength. A gear reduction slightly in excess of that found in the Ford car is sometimes effected by using a rear wheel of smaller diameter. In case of one outfit this wheel diameter is made twenty-four inches in place of the original thirty, which would reduce the speed to such an extent that with the engine running at the number of revolutions which would correspond to twenty miles an hour with the touring car, the actual speed with the smaller wheel would be about sixteen miles an hour.

Another class of converters is that in which the wheelbase of the Ford is lengthened so that the remodeled car will accommodate a longer body than one which could be used when the distance between the axles is only one hundred inches. Such a device does not increase the load capacity in pounds, but does

increase it in cubic feet. These extension attachment consist of an additional length of steel channel and a

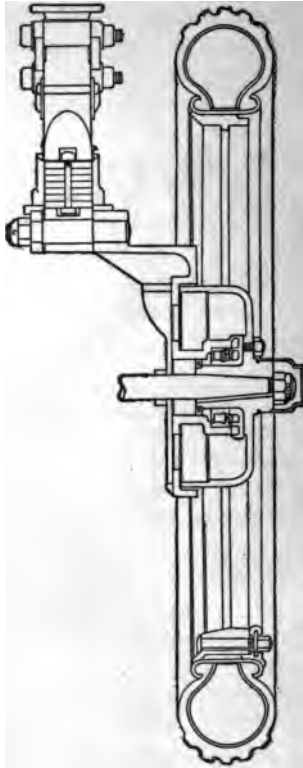

Figure 69.—Section Through Reinforced Wheel and Spring Support.

those parts which are necessary to allow the rear axl to be placed farther from the engine. This require a shaft which attaches to the rear end of the trans

mission and which carries the power from this point back to the forward end of the original driveshaft, which is now a considerable distance away from the rear of the transmission. This type is shown in Figure 70.

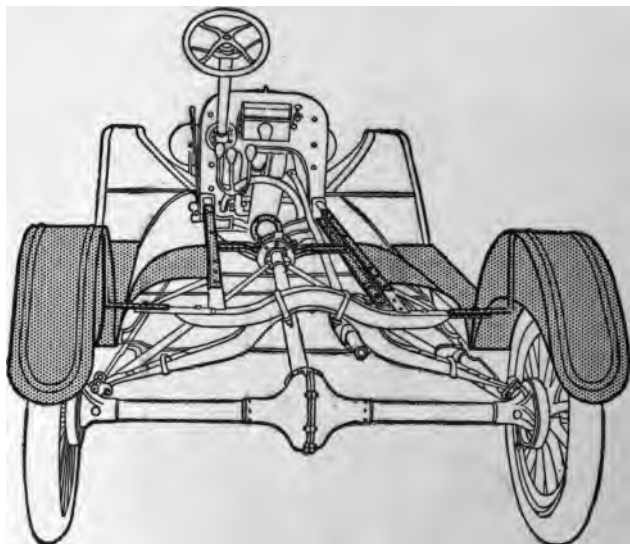
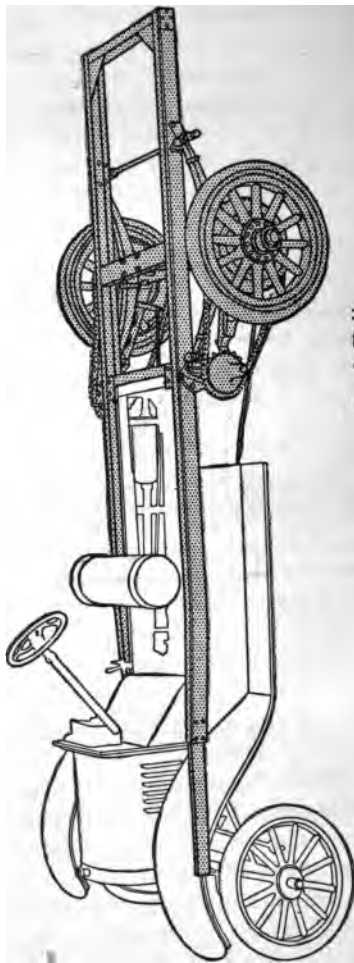

Figure 70.—Ford Frame Extended by Addition at Center.

The type of truck attachment which was first introduced and which early attained the widest popularity is that which is chain driven. While all of the chain-driven units are more or less similar in external appearance, a careful examination shows many points of importance at which one make differs from another. In some of these attachments the forward chain sprockets are fastened to the end of the Ford axle which is

**FORD MOTOR CAR**



**Figure 71.—Chain Driven Truck Unit.**

being used as a jackshaft and are in such a position that the chain is in line with the old rear wheel. This construction allows the new rear wheels on the truck attachment to be further apart than the standard tread of the Ford car, so that the tread of the new unit becomes more like that used on some of the larger trucks, that is, farther across from wheel to wheel. With other constructions the sprockets or the sprocket carrier which goes on the end of the Ford axle jackshaft is so designed that the teeth which carry the chain are brought closer to the frame so that the new rear wheels may have the standard tread, which is fifty-six inches. A standard form of chain-driven adapter is shown in Figure 71.

#### TRACTOR ATTACHMENTS

The Ford car or its power plant may be made to serve as a tractor of either one of two principal forms. One method provides a strongly built rear axle giving a very great reduction in speed and so designed that this rear axle of the tractor unit serves as the front support for a wagon or truck body. The rear wheels of the wagon or truck are usually placed almost in the center of the load carrying space or platform so that nearly the whole load is borne by the rear axle of the load carrying member, leaving only that part required for proper balancing to be carried by the rear axle of the tractor to which the Ford power plant has been attached.

This construction will allow the carrying of loads up to five tons which are moved by the Ford engine. In order to secure sufficient power for such work the engine is allowed to run at a speed that would correspond to about twenty-five miles per hour in the Ford



car used as a pleasure vehicle. At this engine speed the tractor will move between six and eight miles per hour, which serves to multiply the effective power three or four times with a proportionate reduction in road speed of the device.

The power may be carried from the engine to the tractor axle by means of chain, internal gear or worm drive; the only requirement being that the gear reduction be great enough for the work to be done. Because of the comparatively high engine speed with low vehicle speed it is often found that the standard Ford cooling system as designed for the pleasure car is not effective in the new work, and in this case it is possible to add a pump to the water system which will force the fluid through the engine jackets and radiator at much greater speed than is found with the thermo-syphon principle, and with accordingly greater cooling effect. In some designs of tractor attachments an addition is also made to the oiling system so that the lubricant is driven to the bearings in greater quantity than in the original construction.

With any form of commercial car it is desirable that the unit be kept below a certain predetermined safe maxim of road and engine speed. This limit is usually secured by the use of a governor of any one of the many forms in general use. The use of a governor is especially desirable in tractor work because the very low road speed forms a constant temptation for the driver to increase the engine speed to such an extent that the trip will be made in less time, but at the expense of the mechanical parts of the power plant which are not designed for such heavy work combined with high rotative speed.

A second form of tractor into which the Ford car

may be fitted as the power element is especially designed and suited for farm work. In this case the rear end of the pleasure car chassis is fitted into two wheels of very large diameter and the rear axle of the

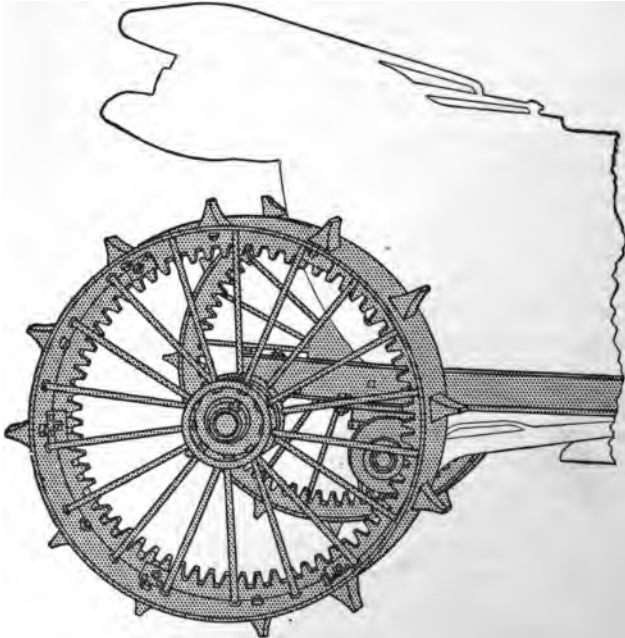

Figure 72.—Internal Gear Tractor.

car is attached to gearing in these wheels so that, with a normal engine speed, the tractor travels at from two to four miles an hour. This type is shown in Figure 72.

The tractor wheels may follow any of the generally accepted types of design for this class of work and

the connection between the Ford rear axle shafts and the tractor wheels is generally secured by some modified form of internal or external gear drive, rather than through chains or a worm and worm wheel drive. This form of tractor is able to pull a very heavy load at low speed or is able to do plowing or any of the other classes of work for which other farm tractors of low and medium power may be used.

## INDEX

	Page
Acetylene gas generator.....	204
Advance of spark.....	41
Ammeter.....	226
Anti-freezing solutions.....	104
Axle, front.....	70
rear.....	67
Battery.....	214
connections.....	209
system.....	45
Battery testing hydrometer.....	217
Battery with ignition and lighting system.....	207
Bearing adjustment.....	144
Bearings.....	142, 167
front wheel.....	71
scraping.....	149
Brakes.....	162
Brake, rear wheel.....	62
Braking system.....	81
Carbon.....	121
deposit, prevention of.....	123
removal.....	180
Carburetor adjustment.....	29, 155
Carburetor and fuel system.....	25
Carburetor trouble.....	198
Care of car.....	105
Casings.....	173
Chain drive.....	241
Chassis.....	11
Clutch.....	56, 156
Cold weather procedure.....	102
Commutator.....	89
oiling.....	108
parts of.....	152
Compression loss.....	128
Compression stroke.....	16
Construction of Ford engine.....	24
Control.....	11
Control pedals of transmission.....	58
Cooling system.....	48
Cranking engine.....	88
Current paths.....	43
Differential.....	63
Differential spider and gears.....	65
Drive system.....	11
Drive, triangular.....	62
Driving.....	85
Driving and control.....	77
Driving parts of lighting dynamo and starting motor.....	224
Driving system.....	60

	Page
Dynamo connections.....	24
Electric starting and lighting.....	24
Engine.....	1
auxiliaries.....	11
construction.....	1
four-cycle.....	1
four-cylinder.....	1
order of firing.....	1
removing from frame.....	12
sudden stopping of.....	17
Exhaust manifold.....	1
stroke.....	1
valve timing.....	11
Firing order of engine.....	1
Flywheel.....	11
Focusing lamps.....	22
Four-cycle engine.....	1
Four-cylinder engine.....	1
Frame.....	1
Front axle.....	1
Front axle and steering gear.....	16
Fuel tank.....	1
Fuel supply.....	1
Fuel system.....	1
Fuses, use of.....	23
Gas generator, acetylene.....	24
Gears.....	77, 16
Gear, steering.....	11
General instructions.....	11
Grinding valves.....	11
Hydrometer.....	21
Ignition adjustment.....	11
circuit.....	1
coil.....	1
commutator.....	1
system.....	1
trouble.....	11
wiring.....	1
Indicating instrument faults.....	2
Inlet manifold.....	1
stroke.....	11
valve timing.....	11
Inner tube cuts and tears.....	17
Inner tube punctures.....	17
Internal gear rear axle.....	2
Internal gear tractor.....	21
Joint, universal.....	1
Lamp bases.....	2
Lamp focusing adjustments.....	2
Lamps and wiring.....	2
Levers, spark and throttle.....	1
Lighting dynamo.....	2
electric.....	2
electric attachments.....	2
trouble.....	2
Lubrication.....	1
Magneto.....	1
Manifolds, exhaust and inlet.....	1
Muffler.....	1
care of.....	1
Noise in engine.....	1

	PAGE
Oiling chart.....	106
system .....	47
the commutator .....	106
One-wire method.....	222
Overheating of engine.....	186
Pedals, control, of transmission.....	58
Piston rings.....	14, 127
Planetary gears in transmission.....	54
Power elements of an engine.....	15
Power loss in engine.....	179
Power of tractor.....	252
Power plant.....	9
repair .....	125
Power stroke.....	16
Punctures, inner tube.....	172
Radiator repair.....	154
Radius rods.....	70
Rear axle.....	67
Rear axle and brakes.....	162
internal gear.....	242
Removal of carbon.....	180
Removing engine from frame.....	125
Repair of power plant.....	125
or radiator.....	154
Retard of spark.....	41
Reversing .....	95
Revolution .....	15
Running gear.....	11, 69
Running gear adjustments.....	156
Scraping bearings.....	149
Sediment trap.....	27
Setting timing gears.....	137
Skidding .....	93
Spark advance and retard.....	41
Spark and throttle levers.....	84
Spark plugs.....	43
Spindle and bearings, front wheel.....	71
Springs .....	166
front and rear.....	75
Starting and lighting trouble.....	224
Starting car.....	89
Starting, electric.....	204
Starting motor.....	213
Steering gear.....	77, 165
wheel .....	78
Stopping .....	91
Storage battery.....	212, 214
Stroke and revolution .....	15
Stroke, compression.....	16
exhaust .....	17
inlet .....	15
power .....	16
Suspension, three-point.....	75
Throttle levers.....	84
Timing, exhaust valve.....	132
gears .....	137
inlet valve.....	133
valve .....	131
Tires .....	169
Tractor attachments.....	235, 249
Tractor, internal gear.....	251