



This is a digital copy of a book that was preserved for generations on library shelves before it was carefully scanned by Google as part of a project to make the world's books discoverable online.

It has survived long enough for the copyright to expire and the book to enter the public domain. A public domain book is one that was never subject to copyright or whose legal copyright term has expired. Whether a book is in the public domain may vary country to country. Public domain books are our gateways to the past, representing a wealth of history, culture and knowledge that's often difficult to discover.

Marks, notations and other marginalia present in the original volume will appear in this file - a reminder of this book's long journey from the publisher to a library and finally to you.

Usage guidelines

Google is proud to partner with libraries to digitize public domain materials and make them widely accessible. Public domain books belong to the public and we are merely their custodians. Nevertheless, this work is expensive, so in order to keep providing this resource, we have taken steps to prevent abuse by commercial parties, including placing technical restrictions on automated querying.

We also ask that you:

- + *Make non-commercial use of the files* We designed Google Book Search for use by individuals, and we request that you use these files for personal, non-commercial purposes.
- + *Refrain from automated querying* Do not send automated queries of any sort to Google's system: If you are conducting research on machine translation, optical character recognition or other areas where access to a large amount of text is helpful, please contact us. We encourage the use of public domain materials for these purposes and may be able to help.
- + *Maintain attribution* The Google "watermark" you see on each file is essential for informing people about this project and helping them find additional materials through Google Book Search. Please do not remove it.
- + *Keep it legal* Whatever your use, remember that you are responsible for ensuring that what you are doing is legal. Do not assume that just because we believe a book is in the public domain for users in the United States, that the work is also in the public domain for users in other countries. Whether a book is still in copyright varies from country to country, and we can't offer guidance on whether any specific use of any specific book is allowed. Please do not assume that a book's appearance in Google Book Search means it can be used in any manner anywhere in the world. Copyright infringement liability can be quite severe.

About Google Book Search

Google's mission is to organize the world's information and to make it universally accessible and useful. Google Book Search helps readers discover the world's books while helping authors and publishers reach new audiences. You can search through the full text of this book on the web at <http://books.google.com/>

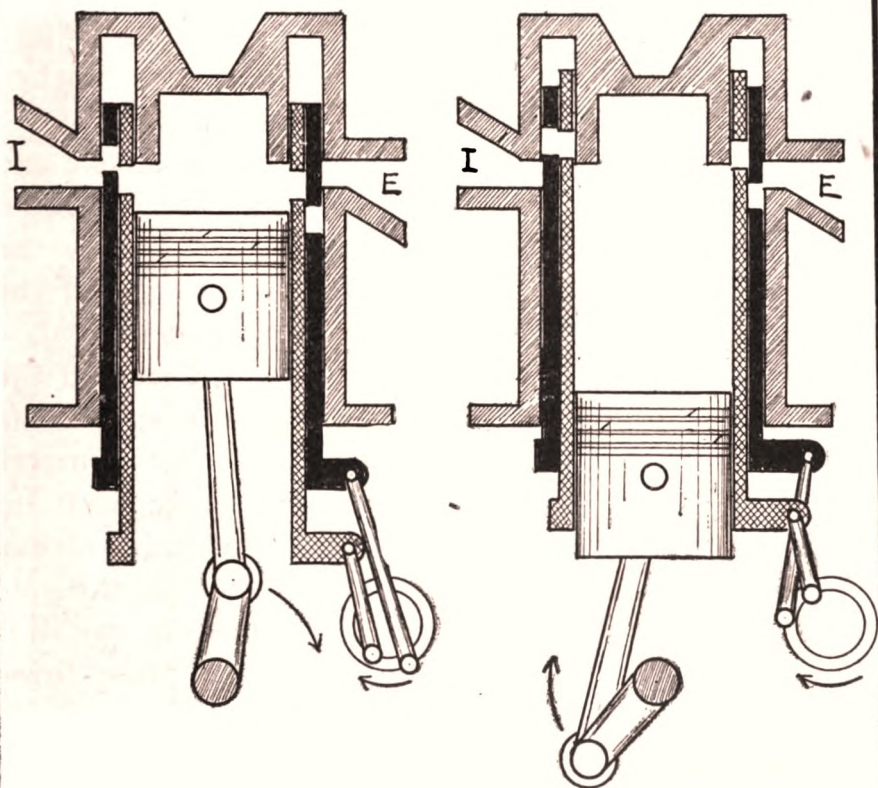

The modern motor car

Harold Phillips Manly



[REDACTED]

[REDACTED]

[REDACTED]

[REDACTED]

[REDACTED]

FRUIT H. WENDY LIBRARY
COLLEGE OF ENGINEERING
UNIVERSITY OF WISCONSIN
MADISON, WI 53706

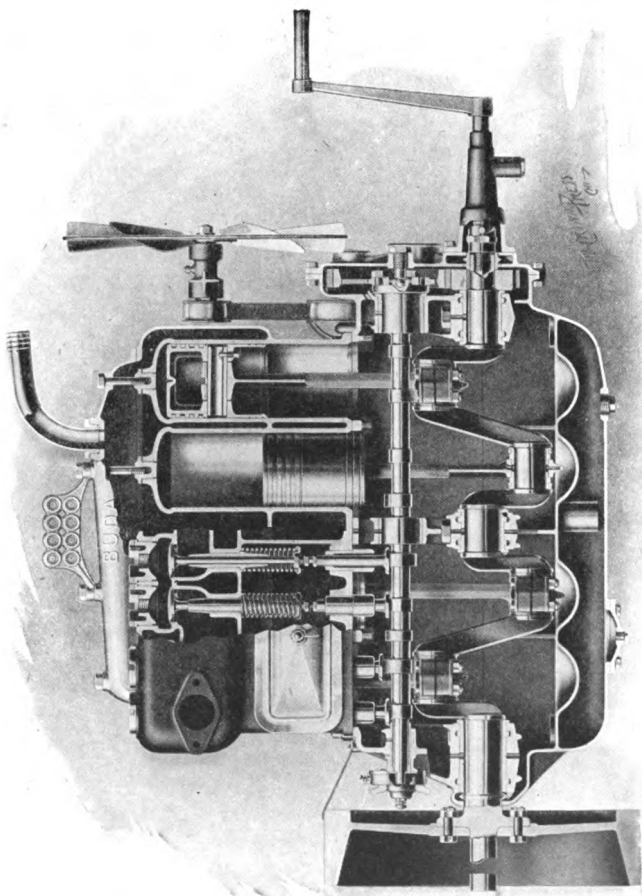

FOUR CYLINDER VERTICAL AUTOMOBILE ENGINE.

THE MODERN MOTOR CAR

A BOOK OF SIMPLIFIED UPKEEP

BY
HAROLD P. MANLY

Construction, Care and Adjustment of Motor
Car Units, together with Shop and Roadside
Methods of Trouble Location and Repair

HOW TO BUY, MAKE AND USE
MATERIALS AND SUPPLIES

Operation and Repair of Electric Engine Starters,
Lighting Systems, Magnetos and Ignition
Parts, Electric Brake, Gear Shift, Etc.

FOR
REPAIRMEN, OWNERS, DRIVERS, SALESMEN AND STUDENTS

506 PAGES — 217 ILLUSTRATIONS



CHICAGO
LAIRD & LEE, INC., PUBLISHERS

Acknowledgement is made of our indebtedness for valuable assistance given by the manufacturers of the various automobile components treated.

COPYRIGHT, 1914, BY LAIRD & LEE, INC.

The publishers and author will be grateful to readers who will be kind enough to make criticisms and suggestions helpful to the continued improvement of this book.

INTRODUCTION

REPAIRMEN, owners, drivers, students and salesmen need an every-day book of reference containing all available information applying to their needs, clearly and simply written, arranged for the quickest possible use and thoroughly covering the subjects of shop and roadside methods of repair and adjustment, the use of operating materials and supplies, and the construction, operation and care of electric lighting, starting and ignition systems.

The electrical equipment is, for the first time, completely treated, including lighting, starting, ignition and control, explained in such a way that the average man without electrical experience may be able to properly handle, care for and repair every electrical unit.

Three-fourths of the entire book has been given to the following :

REPAIR METHODS AND PRACTICE.

TROUBLES AND THEIR REMEDIES.

ADJUSTMENT. CARE. FITTING.

REMOVAL, REPLACEMENT, DIS-ASSEMBLING AND ASSEMBLING.

The remainder has been given to a complete, yet brief explanation, of the design, construction, type and use of the various parts of the car.

A clear conception of the underlying principles in their application to actual practice is first given, preparing the user for the following detailed methods and simple rules for making correct adjustments and repairs on all parts used in the automobile. This book has been written under the conviction that, to make it practical, nothing should be taken for granted. Therefore, every part and operation is explained from the ground up, in a way understandable alike to the novice and the experienced man.

The book has been designed, not to compete with the general treatises now available, but to furnish a work of reference for the automobile worker or owner, treating the subjects wholly from the standpoint of the man using the car for business or pleasure or as a means of livelihood, as a practical repairman or operator.

Every development found in the modern car has been covered in a condensed form, giving the greatest possible amount of information in a book of the most convenient size while still retaining full and complete explanation.

The arrangement is such as allows the quickest possible finding of any desired method or fact, this result being accomplished by the plan of the subject matter throughout the text and through the index which lists every point under all probable and possible headings with complete cross references.

Some things have been intentionally omitted, these being: history and past development, personal prejudice or opinion, miscellaneous extracts from magazines and trade papers, unimportant matter oftentimes used to produce a large book, and details of theory or design interesting only to the student of engineering practice.

The matter presented is the result of eleven years' work in designing, building, operating and repairing gasoline-propelled vehicles in pleasure car, truck and motorcycle factories, successful garages and repair shops, and in the sales departments of factories and distributors.

Many parts of the work have been used for instruction in shop practice for repairmen and drivers, and for all of these reasons it is believed that this book will prove of the most practical help and profit in everyday use, the feeling that a source of practical information is quickly available making it a greater pleasure to drive and a more profitable undertaking to repair the modern automobile.

H. P. MANLY,

CONTENTS

For Alphabetical Cross-Index see end of volume.

INTRODUCTION

SECTION ONE

	PAGE
MOTOR CAR PARTS, THEIR CONSTRUCTION, USE, CARE AND REPAIR,	3-206

SECTION TWO

MATERIALS AND SUPPLIES, HOW TO USE, BUY OR MAKE MATERIALS AND SUPPLIES USED IN RUNNING A CAR,	3-20
---	------

SECTION THREE

ELECTRICITY — ITS PRINCIPLES EXPLAINED,	3-28
---	------

SECTION FOUR

ELECTRIC LIGHTING AND STARTING,	3-137
---	-------

SECTION FIVE

IGNITION — DESIGN, CONSTRUCTION, USE, CARE AND REPAIR OF VARIOUS UNITS,	3-82
--	------

ALPHABETICAL INDEX,	I-XXIV
-------------------------------	--------

List of Illustrations

Section I

Four cylinder vertical automobile engine.....	Frontispiece
Front axle and wheel	4
Floating rear axle	6
Brace for strengthening rear axle housing.....	9
Annular ball bearing	13
Cup and cone ball bearing application	16
Solid bearing	19
Split bearing	19
Oil grooves in bearing	19
Connecting rod bearing	19
Plain bearing shim	19
Clamp for truing shafts	19
Hyatt flexible steel roller	25
Roller bearing with outer sleeve only	25
Roller bearing	26
Roller bearing with inner and outer sleeves	27
Internal brake	29
External brake	29
Pull rod with turnbuckle adjustment	30
Brake or control pull rods	30
Brake equalizers	31
Cam and valve opening mechanism	33
Carter carburetor	36
Holley carburetor used on light cars	45
Holley Model "H" carburetor	46
Kingston carburetor used on Ford cars	46
Kingston carburetor	47
Interior of Model "G" Rayfield carburetor	48
Rayfield Model "G" carburetor	50
Schebler Models carburetor	51-55
Stromberg carburetor, types	56-60
Electric carburetor heater	68
Electric heating plug in inlet manifold	69
Cross shaft and arms for releasing clutch	76
Clutch and brake pedals	77
Cone clutch	79
Dry plate clutch parts	83
Multiple disc clutch parts	84
Points at which compression may be lost	88

Effect of bent connecting rod	90
Tubular radiator	92
Cellular radiator	92
Indicator for temperature of water	94
Parts that carry the power	96
Principle of the differential	101
Eight cylinder engine connecting rods	106
Straightening a bent frame	112
Vacuum fuel feed system	117
Circulating oiling system in engine crank case	124
Removing piston rings	133
Elliptic springs	143
Platform spring	143
Worm and sector steering gear	147
Air valve for automobile tire	153
Tire pressure gauge	154
Selective sliding gear transmission	159
Sliding gear transmission, end view	160
Brake and gear shift hand levers	161
Principle of the planetary transmission	165
Friction change speed gearing	170
Two port, two cycle engine	173
Differential piston two cycle engine	178
Positions of valve opening and closing	185
Inlet, compression, power and exhaust strokes	185
Sleeve valve eccentric shaft	190
Inlet and compression stroke of sleeve valve engine	191
Power stroke of sleeve valve engine	193
Rotary valve engine	194

Section III

Lighting and starting battery	7
Flow of direct current	9
Series lamp connection	10
Multiple lamp connection	10
Magnetic field and lines of force	17
Electro magnet polarity	22
High tension transformer coil	25
Principle of the induction coil	26

Section IV

Dynamo mounted in place of magneto	5
Dynamo lighting system on car	7
Floating the battery on the line	9
The flow of water and electricity compared	10
Starting motor installation	13
Separate unit system	14
Combined unit system	15

Lighting generator with cutout.....	16
Principle of dynamo action.....	18
Field magnets and windings.....	20
Field windings	21
Dynamo parts	22
Armature coil, commutator and brushes.....	24
Armature windings	25
Brush	26
Commutator housing and brushes.....	28
Permanent magnet dynamo.....	30
Series field winding	32
Shunt field winding	33
Compound field winding	33
Bucking coil winding	33
Combined dynamo and motor.....	38
Overrunning clutch principle	48
Typical overrunning clutch	49
Starting and lighting wiring diagram.....	52
Broken lamp wires	53
Electric side lamp	54
Electric tail lamp	55
Comparative sizes of lamp bulbs.....	56
Ediswan lamp base	59
Trouble finding lamp	60
Lighting systems—one, two, three wire.....	63
Distribution panel and switch housing.....	65
Starting switch	67
Circular contact switch	68
Switches—various	69
Tester for locating faults.....	71
Voltmeter and ammeter connecting.....	74
Three cell storage battery.....	77
Lead cells units	78
Interior of storage battery	79
Section through lead cell.....	80
Lead cell parts	83
Top connections of battery.....	84
Typical starting battery	85
Battery testing hydrometer	86
Layout of starting and lighting units.....	89
Battery charging	92
Arrangement of storage battery interior.....	94
Edison battery	96-100
Hand operated cut-out.....	102
Centrifugal cut-out	103
Electro-magnetic cut-out	105
Shunt connected cut-out	107
Compound wound cut-out	107
Cut-out with weakening resistance coil.....	107
Lighting system ammeter	109

Output control, shunt field resistance.....	115-120
Controller and cut-out.....	117
Wiring of solenoid regulator.....	118
Regulator and cut-out.....	119
Iron wire control.....	122
Bucking coil control.....	122
Controller.....	123-124
Constant armature speed control.....	125
Starting motor.....	128
Starting motor on clutch shaft.....	129
Starting motor on transmission case.....	129
Electric brake motor.....	130
Inventor of the electric brake.....	131
Brake controller.....	132
Wiring of electric brake.....	132
Ammeter readings under various conditions.....	136

Section V

Bosch magneto breaker.....	3
Splitdorf magneto breaker.....	4
Master vibrator wiring.....	7
Single unit vibrating coil.....	9
Four unit ignition coil.....	10
Four unit coil and timer wiring.....	11
Typical dry cell.....	17
Battery testing ammeter.....	18
Dry cell connections.....	20
Battery connector.....	21
Distributor and timer.....	23
High tension distributor.....	25
Make and break spark coil.....	29
High tension magneto armature.....	34
Magneto parts.....	36
Waterproof magneto.....	37
Dual magneto.....	39
Magneto inductors.....	40
Armature position.....	44
Magneto breaker, Swiss.....	47
Magneto with breaker cover removed.....	48
Magneto with distributor cover removed.....	49
Single or double ignition wiring.....	51
High tension dual magneto wiring.....	53
Coils—various.....	57
Wiring for magneto with dash coil.....	59
Unisparker.....	63
Half inch spark plug.....	70
A. L. A. M. spark plug.....	71
Two spark ignition.....	75
Four cylinder timer.....	77
Vibrator and coil parts.....	81

SECTION ONE

Construction, Use, Care and Repair of Motor Car Parts.

Subjects in this section are arranged alphabetically under the name of the part.

Each subject is treated in divisions, the point treated being indicated by an initial letter before the paragraph.

The letters and their meanings are as follows:

- D.** Design, Use and Construction.
- C.** Care Required.
- A.** Adjustment Methods.
- R.** Removal and Replacement.
- T.** Troubles and Repair Methods.

AXLES.

Front Axle. D. Front axles are made in four designs, the commonest being an "I" Beam section, next in order of use being the solid round, square or hexagonal type. Less used types are the hollow tube and another type formed by two channel pieces placed together to make a box-like enclosure.

Axles of the first two designs are made from steel drop forgings, tubular axles are of seamless steel and the channel axles have the parts pressed to shape while cold.

C. The long vertical bolts holding the steering knuckles into each end of the front axle must be kept parallel to each other and they must stand exactly vertical when looked at from the front of the car.

The spindles on which the front wheels turn should be bent down at the outer end so that the point at which the tire rests on the road will be almost, if not quite, underneath the vertical knuckle bolt. This makes the car steer easily.

A. Should the axle not meet the above conditions the bent parts should be heated dull red and carefully bent to correct shape.

R. In reassembling the front axle with its steering knuckles and the cross tie rod, the knuckles should first be placed on the ends of the axle and the long bolts put in place. The tie rod should then be attached with its bolts. As each part is fastened in place make sure that it moves freely.

T. A bent front axle causes hard steering and wears the tread from one or both front tires very rapidly.

For explanation of letters appearing before paragraphs see page one.

MOTOR CAR PARTS

An axle thought to be bent should be run over a level floor or else over a straight bar and the position of the bolts and shape of the axle tested with a steel square.

Bent axles, if not too much out of line, may be

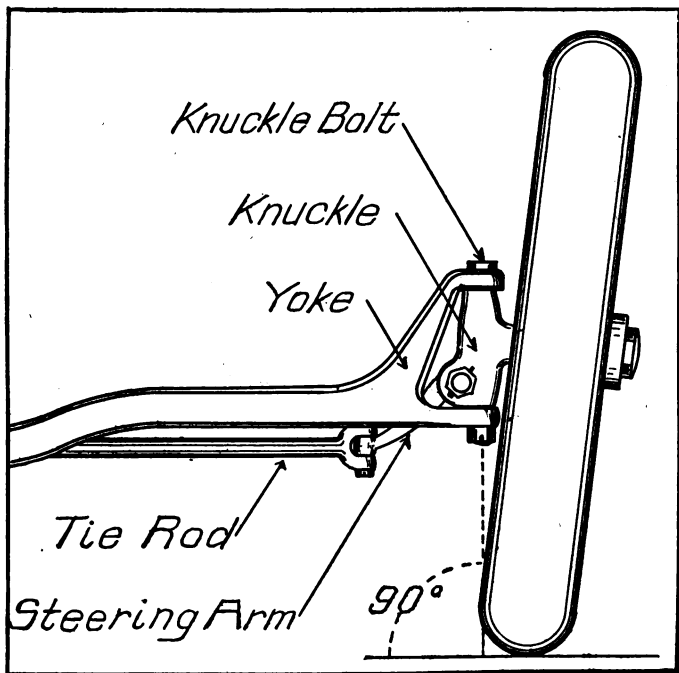

FRONT AXLE AND WHEEL.

straightened by placing the base of a jack against the high part and running a chain over the top of the jack and fastening the ends of the chain to the axle ends.

A bent axle may also be straightened by fastening a long bar to the axle, wrapping a chain around the

axle and bar. The axle may then be caught between any two solid posts or supports and pressure applied to the end of the bar to straighten the axle.

Rear Axle. D. Rear axles are divided into "Live Axles" in which the shafts are carried inside a tubular housing, the center of the housing being large enough to carry the differential and bevel gears; or "Dead Axles" which are solid from end to end, the wheels being driven by chains.

Live axles are divided into three classes in common use today.

"Full Floating Rear Axles" have the differential carried on bearings in the housing, the road wheels being mounted on two bearings in each hub, which run on the outside of the ends of the housing. The driving shaft is stuck into the differential at the inner end and the outer end of this shaft is carried by a two, four or six jawed clutch. The axle end passes into a hole in the center of the clutch and the jaws of the clutch mesh into teeth in the hub of the wheel. The shaft thus carries no load.

"Semi-Floating Rear Axles" have the differential carried on bearings in the housing, the inner end of the driving shaft being stuck into the differential. The outer end of the driving shaft is carried on a bearing inside the end of the housing and the wheel hub is fitted onto the end of the driving shaft. The wheel is held on by nuts or pins, the end of the axle shaft being tapered, squared or keyed.

"Three Quarter Floating Axles" have the differential carried on bearings in the housing, the inner end of the driving shaft being stuck into the differential. The road wheel is carried on a single bearing on the

outside of the end of the housing, the wheel hub fitting over this bearing. The driving shaft extends

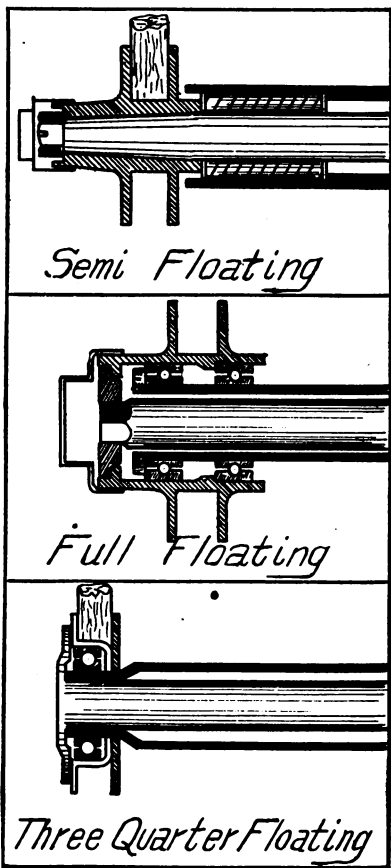

THREE TYPES OF LIVE REAR AXLES.

through the housing to a point outside the wheel and carries a large plate at its outer end. This plate bolts

to another plate fastened to the wheel hub so that the shaft is supported by the wheel and the wheel is prevented from turning out of true or wobbling by the driving shaft. When the wheel is placed on the axle the depression in the plate on the wheel should face outward. The bearing is then slipped into this depression from the outside and fastened with nuts on the housing. The driving shaft is then pushed into place in the differential bringing its flange plate into position for bolting to the hub.

An old and little used type called a "Live Axle" has the driving shaft carried in a bearing at each end of the shaft inside the housing. The differential is then carried by the inner end of the shaft and the road wheel by the outer end.

C. Rear axles should be filled to a depth of $1\frac{1}{2}$ to 3 inches with very light transmission grease or with cylinder oil. The housing at the center should be filled only to a point at which the large bevel gear will dip into the oil or grease. Never pack an axle full of grease.

A. The driving bevel gears may become noisy by not being properly meshed. To make this adjustment—

Block up the rear of the car so that both rear wheels are off the floor. Start the engine, place the gears in high speed and let the clutch in. Now make sure that the noise is in the rear axle and not in the transmission, the engine gears, or other parts of the car.

The bearing just in front of the small bevel driving pinion should have means for throwing the pinion backward or forward in or out of mesh with the larger gear. Set the small pinion backward or forward a

very little at a time until the noise disappears. If the noise does not disappear replace the small bevel in the same position as when you started.

The bearing carrying the bevel gear side of the differential should have means for throwing the differential slightly to the right or left. This may be done, a very little at a time until the noise disappears. In case this bearing has no adjustment the washers may be removed and thinner ones put in, or else thin brass shims may be placed between the bearing and differential case.

In some cases both pinion and gear may have to be adjusted, but if this does not correct the trouble, the gears are too badly worn or are loose on the drive shaft or differential case or the differential runs out of line or the bearings may be loose or worn out.

R. In reassembling a rear axle each part should be tried as it is placed in position to see that it turns freely.

All housing joints should have paper gaskets well shellaced and should be bolted tight.

T. The rear axle housing carries the springs on spring seats which may be designed to turn on the axle housing, being in the form of a bearing and having a grease cup. Looseness at this bearing causes a loud knock when the car is driven off a bump in the road at fair speed. This bearing should be treated like any other plain bearing in adjustment required.

If the rear axle housing leaks oil at the wheel ends so that the brakes, hubs and even the wheels and rims become covered with oil or grease the trouble is probably that the housing has been filled too full of oil. This may be corrected by first draining the grease

or oil to the proper level, removing the wheels and washing the grease from all exposed parts and removing it from the brake linings as directed under "Brakes."

The driving shaft should be removed and the grease washers or packing or drain tubes should be cleaned or replaced. Should the axle still leak oil or grease the wheel may be removed and the bearings inside the outer end of the housing taken out and about a pound of waste stuffed into each end of the axle.

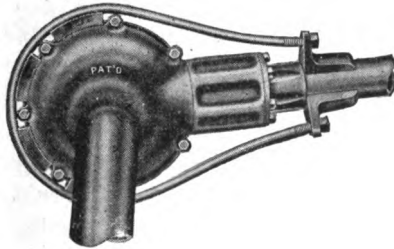

BRACE FOR STRENGTHENING REAR AXLE HOUSING.

Full floating axle loose wheels may be tightened by adjusting the wheel bearings as directed under "Bearings."

Full floating axles having play in the wheel jaw clutches make a rattling noise at the rear of the car. The best remedy is to fit new clutches or new hubs or both, but a very good repair may be made by heating the clutches slowly to a red heat and hammering them out so that they will take up the play. The clutches should then be tempered and the driving faces case hardened, after dressing to an exact fit. A temporary repair may be effected by placing thin sheets

of brass shim stock between the clutches and hub teeth. Thin steel would make a more permanent job.

Semi-floating axles often have the driving shaft bent by skidding, hitting the curb or going over bumps too hard. To remove the shaft take the wheel off the end, remove the bearing inside the end of the housing and pull the shaft out of the differential. To remove the wheel first take the hub cap off, then remove or loosen the cotter pin, straight pin, or other locking device for the nut, then take off the nut (which may have either a right or left hand thread) and then try to pull the wheel off by hand.

If the wheel does not come off, catch the jaws of a wheel puller over the edges of the brake drum and place the point of the screw in the small hole in the center of the end of the axle.

In replacing the wheel turn the driving shaft until the keyway is on top, lay the key in the keyway and slip the wheel on the shaft, holding the keyway in the hub uppermost. It is a good idea to slightly oil the end of the shaft before replacing the wheel.

Three quarter floating axles, being a combination of the other two types may have some of the troubles of each as well as having some of the advantages and some of the disadvantages of each.

BALL JOINTS.

D. These joints allow movement in any direction and are made up of a steel ball which slips into the end of a tubular piece. The neck of the ball passes into a slit cut along one side of the tubular piece and the ball comes up against a spherical end of the tube on the inside. A plug is then screwed or slid into the tubular piece, closing the end through which the ball passed. This plug is cup shaped at the end touching the ball. If the plug slips into the tube there is a screw plug that follows it and holds it in place. Some ball joints have short, heavy coil springs placed back of the cup ended plugs.

Ball joints, or ball and socket joints, are used for the rod from the front axle to the arm on the steering gear and for the radius or distance or torsion rod ends in some cases. Small ball joints are used on the rods operating the spark and throttle controls and for any other small control rods on the car.

C. Ball and socket joints should be lubricated with cup grease and the larger types should have leather covers placed around them and strapped on.

A. Ball joints are adjusted and play is removed by screwing the plug farther into the end. The plug is prevented from turning by a cotter pin, straight pin and ring, or taper pin. These pins must first be removed and they must be replaced after the adjustment is made.

T. After long use the ball may become flattened, making a new one necessary. Another trouble is that the tubular piece is worn to such an extent that the slot is large enough so that the ball can slip out of the side. The tubular end must be replaced with a new one as this is a dangerous condition.

BEARINGS.

Annular Ball. D. An annular ball bearing is composed of a circle of steel balls enclosed between an outside and an inside ring. The inside ring is made to fit over the shaft to be supported and has a slight

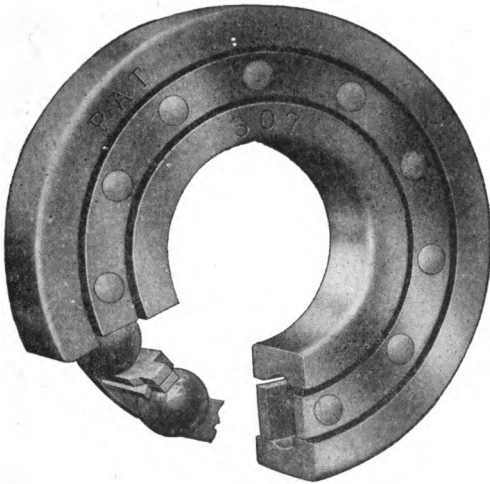

ANNULAR BALL BEARING.

groove cut around it for the balls to roll in. The outside ring fits into the housing or part supporting the shaft, and this ring has a slight groove around its inside surface for the balls to roll in. These rings are made of hardened steel and are called the inside and outside race. The balls are sometimes separated from

each other by small springs or pieces of metal or the balls may be held in a certain position relative to each other while rolling by metal cages in the form of a ring.

Annular ball bearings are most suitable for a radial load or one coming at right angles to the shaft. They will also support an end load of about one-fifth the radial load.

Some annular bearings have one row of balls between the two races and are called "single row annular bearings," while others have two complete rows of balls between the two races and are called "double row annular bearings."

Annular bearings are also made with the outer race made of two separate rings fitting one inside the other. The joint between the two parts is of spherical shape so that the inner part of the race can turn in any direction in the outer part and yet be held tightly. This allows the shaft carried by the bearing to run smoothly even if it is not exactly in line with the bearing support, or a bent shaft will run smoothly in this type of bearing. They are called "self aligning annular ball bearings."

Annular bearings are used where the friction must be very small. They have been used at every point of an engine and car. They are suitable for use in the engine, clutch, transmission, front and rear axle, differential, steering gear, wheels, etc.

C. The annular bearings should be packed with vaseline or light transmission grease of high quality when in the wheels, axles, steering gear, magnetos, etc. When in the engine, transmission or differential, they are oiled by the oil or grease used in these parts.

Annular bearings are not adjustable, the only way of taking up wear is by taking them apart and grinding the races to the correct shape and fitting new and larger balls. This cannot be done in the ordinary shop but the bearings will have to be sent to a ball bearing repair house.

When an annular bearing allows you to feel an up and down play between the two rings or when the rings can be moved sidewise for $1/25$ of the bearing diameter they are loose enough to cause rattling or knocking and should be reground or replaced with new ones if used at a point where slight looseness is undesirable.

R. Annular bearings are removed by first taking off whatever locking nut or washer holds the bearing from moving endwise on the shaft and then sliding the bearing off the end of the shaft. This sliding may take some force inasmuch as annular bearings are made to fit snug both on the shaft and in the holder. However, they should be easily removed if started straight without wedging or jamming.

In replacing annular bearings first be sure that the bearing is free of dirt and grit by washing thoroughly in kerosene or gasoline. Then lubricate the bearing around the balls and in placing the bearing on the shaft or in the holder be sure that it does not wedge in any way and that it stands square on the shaft and in the housing while sliding into place.

Annular bearings usually have felt packing washers at one or both sides of the bearing which are held in place by thin metal rings called dust washers. These washers of felt should fit tightly around the shaft and into the housing in order to prevent the leakage of

grease or oil. New or clean washers should be used or the old ones should be washed with gasoline. In some cases two or three washers may be required to make a tight joint if there is room for the extra thickness.

Cup and Cone. D. This is a cheaper type of ball bearing than the annular type. It is made by having a ring or race to fit over the shaft to be carried, this race being in the shape of a cone on which the balls roll. To hold the balls on the face of the cone there is a cup-shaped outer race which fits over the balls and this outer race fits into the housing or bearing holder. In

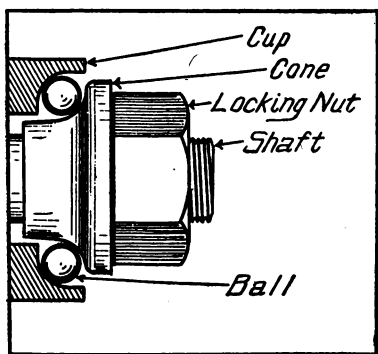

CUP AND CONE BALL BEARING APPLICATION.

the case of a wheel the cup-shaped outer race is held in the wheel and the cone is in the form of a nut that screws onto the end of the shaft. The balls are placed in the cup and the cone holds them in place while rolling.

Cup and cone bearings are used on front wheels of light cars, on cooling fans, and places where the load is light.

C. Cup and cone bearings are lubricated with vaseline or a high grade, light bodied transmission grease. They should be kept clean and free of grit and dirt.

A. This type of bearing is adjusted by placing the wheel or other part on its shaft and filling the cup with grease. The balls may then be stuck into this grease and it will hold them in place while the cone is screwed or pushed over the end of the shaft. If the cone is not threaded inside there will be two locking nuts to go on outside the cone and even if the cone is threaded there will be one nut to lock it. Screw the cone and nut up tight enough to hold the wheel so it can turn but not tight enough to prevent play or shake. Now whirl the wheel and with it whirling slowly tighten the cone until the extra friction stops the wheel from turning easily. Now turn the nut or cone back just far enough to let the wheel or part turn freely and lock in this position.

T. Worn cup and cone bearings can be detected by examining the balls, the cup and the cone. If any of them show pitting or grooves they should be replaced with new parts, as a worn cup and cone bearing may break and cut off the shaft on which it turns.

Plain Bearings. **D.** Plain bearings include all forms made without the use of balls or rollers and in which the motion is a sliding one in place of rolling.

Plain bearings are made of various metals and are in the form of short sections of tube-like form that surround the shaft to be carried and are set into some form of housing or bearing holder. They are sometimes split into two halves so that the bearing may be placed around the shaft at any point or they may be in one solid piece when they have to be slipped over the end of the shaft.

MOTOR CAR PARTS

Plain bearings are made from babbitt metal, white metal or white bronze, brass, bearing bronze and in rare cases from cast iron. Babbitt bearings are poured into place; white metal bearings are made by die casting and must be secured from the makers of the part; brass or bronze bearings are made from bars by lathe work.

Plain bearings have been used at every point in the car, even in the wheels of old cars. They are gradually giving way to the use of ball and roller bearings, but are still almost always found on the connecting rods, wrist pins, crank shaft bearings and cam shaft bearings. They are often used in the transmission and steering gear also. The axles and wheels are usually fitted with ball or roller bearings.

C. Plain bearings must always be kept properly adjusted, as a little looseness soon becomes much worse and may easily cause serious damage to the shafts or breakage of parts. Plain bearings also require much more care in lubrication than ball or roller bearings, about 10 to 30 seconds being the limit that a plain bearing will run without lubrication.

A. When a one-piece or solid plain bearing develops wear and looseness which is at all noticeable when the bearing or shaft is lifted up or down, it must be replaced with a new bearing. Plain solid brass or bronze bearings may be turned out to an inside diameter about $\frac{1}{8}$ to $\frac{3}{16}$ inches larger than the shaft they carry, and the bearing may then be filled with babbitt. The bearing should be replaced whenever possible, however.

When bearings are made in halves the parts of the bearing metal are carried in housings or boxes made of steel, brass, iron or bronze. These housings are then bolted together around the shaft so that the bearing

metal is supported all around by the stronger housing. The main or stationary part holds one-half the bearing and the removable part or cap holds the other half.

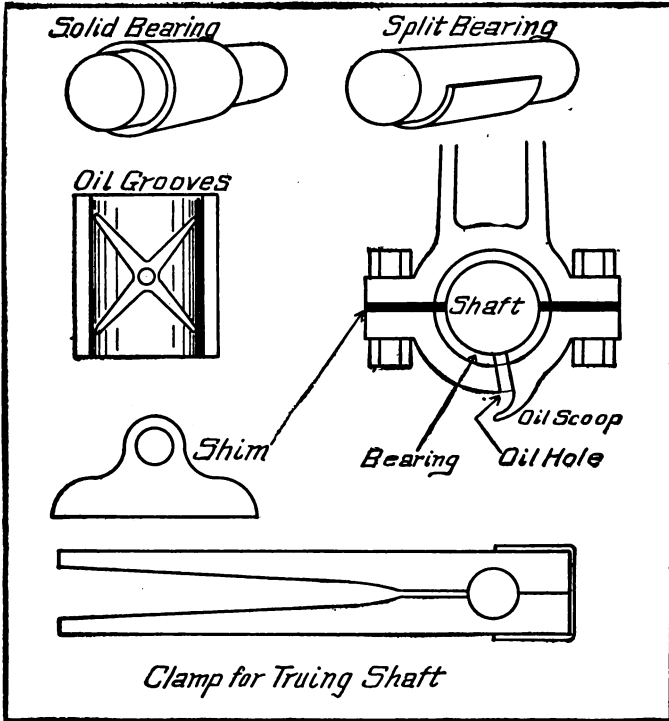

PLAIN BEARINGS, THEIR APPLICATION AND CARE

Some plain bearings are made with the halves slightly separated and having very thin pieces of brass between the edges of the halves. These pieces are called "shims" and there may be a number of them on each side of the bearing.

As the bearing wears, the halves may be brought nearer together by taking off the cap and removing the thinnest shim from each side and then replacing the cap and trying the play. If the bearing is then too tight one shim or else thinner shims must be replaced. When shims are used you must be sure that the metal of the shim covers the cap entirely and also comes tight up against the shaft, entirely covering the edges of the bearing metal pieces.

Shims should be removed until the bearing will not turn on the shaft, then one or two very thin shims should be replaced so that the shaft will just turn, but without play. An even thickness or number of shims should be removed from each side of a bearing. If there are no shims or if the bearing is still loose after removing all the shims the halves may be brought closer together by placing the bearing cap in the vise under very light pressure so that the bearing will not be forced out of shape. With a long flat mill file, some metal is then removed from the edges of the cap by filing straight across, touching both sides evenly and removing an even amount of metal all across. This may be easily done by holding the left hand on the file over the bearing and using the right hand only for moving the file, or the file may be laid flat on the bench and the bearing cap rubbed along the file, pressing evenly on both sides.

After removing a small amount of metal from the cap the same process should be gone through with on the other half of the bearing. The parts should then be bolted around the shaft and the fit tested. Continue this filing until all play disappears, leaving the shaft free to turn. If too much metal is removed make a very thin shim for each side of the bearing.

While the above methods will remove the play temporarily, they do not make a true fit around the shaft for the reason that they take up only the endwise play and do not bring the sides of the bearing any nearer the shaft at the edges of the pieces.

Bearings are properly adjusted and fitted only by scraping to an exact fit.

Scraping requires the use of a "bearing scraper" and "Prussian blue," also great care in the work.

A bearing scraper handle should be held loosely between the fingers of the right hand and the cutting edges of the scraper should lie in the half of the bearing being scraped. The blade of the scraper is lightly pressed onto the bearing surface by the fingers of the left hand and by turning the scraper with the right hand a very small amount of metal may be removed from any part of the bearing surface.

First remove the bearing cap and the halves of the bearing so that the shaft is exposed. If the shaft is rough or pitted or has rings cut around it, the surface must be made smooth, as directed below. If the shaft is perfectly smooth and round take a very little Prussian blue on the tip of the finger and rub it all around the surface of the shaft where it touches the bearing, making a very thin, even layer of the blue. Now remove enough shims or file the holders so that the play is removed and then bolt the bearing to the shaft. Turn the shaft or bearing once or twice around and then remove the bearing. Wherever the bearing touched the shaft the bearing surface will be blue.

Now place the bearing in the vise and with the scraper remove a very thin layer of metal wherever it is blue and then wipe all the Prussian blue off both

sides of the bearing with a clean cloth. With the fore-finger rub the Prussian blue evenly over this (journal) shaft again so that the surface of the (journal) shaft has a very thin and even coat of the blue. Do this with both halves of the bearing and then replace the bearing on the shaft and tighten the bolts. If play is present remove more shims or file the housing more and again turn the shaft or bearing.

Remove the bearing once more and scrape carefully wherever the blue shows. Add more blue to the shaft if necessary and repeat this operation until about two-thirds of the bearing surface comes off blue. This blue should show in an oval shaped patch around the center of the bearing.

After the bearing is properly scraped wash off all the blue with gasoline, cover the bearing and shaft with cylinder oil and replace the bearing on the shaft. While tightening the bolts for the last time it is best to strike the bearing lightly with a hammer as this makes the bearing fit tight to the shaft.

Be sure that the shims extend right through to the shaft so that the bearing metal will not turn inside the cap and holder.

Also be sure that every nut and bolt is locked in place with a cotter pin, double nut, wire through the bolt head, or special lock or whatever means has been provided for holding the nut or bolt. Never depend on a lock washer to hold bearing bolts inside the parts of the car. Neglect of tightening and locking bolts and nuts has been the cause of many wrecked engines.

R. Plain bearings must have some means of getting oil into the bearing aside from what would work in from the ends. To accomplish this, holes are drilled

through the center of one or both halves of a split bearing or in the top or bottom of a solid bearing. Care must be used to see that these holes are not stopped up and that the hole in the bearing metal exactly matches the hole in the cap or holder through which the oil or grease comes.

Starting from this oil hole there are small grooves cut into the surface of the bearing that lead toward the edges. Sometimes they go right to the edge, sometimes they end a half or quarter inch from the edge, their purpose being to distribute the oil. White metal and babbitt bearings require these grooves about one inch apart; brass and bronze should have them about a half inch apart. Care should be used to see that these grooves are free and open before reassembling the bearing.

When plain bearings are used where the shaft extends through the case and bearing in such a way that the oil might be forced out of the case through the bearing some means must be taken for preventing this leakage.

In plain bearings this usually takes the form of a deep groove cut all the way around the inside of the bearing near the outer end. There is a small hole drilled through the bearing into this groove and on the bottom. This hole leads back into the crank case, transmission case, axle housing, etc., so that oil passing out of the bearing is caught in the groove and returned.

An extension of the case is sometimes carried outside the bearing so that oil may be caught in the extension and returned to the case through a tube.

T. Should the shaft on which a plain bearing is

mounted become rough or pitted or scratched it may be turned down in the lathe to a smooth surface.

Another method of securing a smooth surface is to take two pieces of wood about $1\frac{1}{2}$ by $2\frac{1}{2}$ inches and 2 feet long. Lay these pieces with the narrow edges touching and around the outside of one end screw a strap so that the pieces are hinged together. Still holding the pieces together, cut a hole so that half the hole is in each piece, this hole to be about 3 inches from one end and of the same diameter as the shaft to be treated. Tack a medium grade of emery cloth to the wood pieces so that the cloth fits around the halves of the hole with the emery side away from the wood. Now clamp this around the shaft with the hands so that the emery touches the rough part. Apply some pressure by holding the free ends of the wood pieces together while the shaft is turned in the car or while mounted between the lathe centers. In a short time this action will bring the surface of the shaft smooth, although it will not necessarily make it perfectly round.

Roller. D. A roller bearing is composed of a circle of steel rollers enclosed between an outside and inside ring. The inside ring fits over the shaft to be supported and the outside ring fits into the housing or tube that carries the bearing. These rings are made of hardened steel and are called the inside and outside races. The rollers may be prevented from touching each other by having their ends carried by some form of metal cage or retainer that holds them the proper distance from the roll at each side while they roll between the races.

Some forms of roller bearings are made so that the rollers rest directly on the shaft without the use of

an inner race, others are made so that the rollers fit inside the housing without the use of an outer race.

The rollers may be of solid steel or they may be formed from thin flat steel twisted into a spiral roll.



HYATT FLEXIBLE STEEL ROLLER.

These are called flexible roller bearings.

Solid rollers may be made either straight or tapered, the races of course being straight or tapered accordingly.

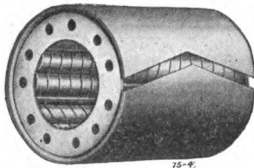

ROLLER BEARING WITH OUTER SLEEVE ONLY.

Roller bearings have been used at every point of the automobile except the connecting rod and wrist pin bearings, but are found principally in the transmission, rear axle and wheels.

C. All forms of roller bearings should be packed with vaseline or a light bodied high grade transmission grease if used in wheels, axles, steering gears, etc. If in the engine or transmission case they will be oiled with the grease or cylinder oil used in these parts.

Taper roller bearings must be kept properly adjusted, clean and free of all forms of dirt.

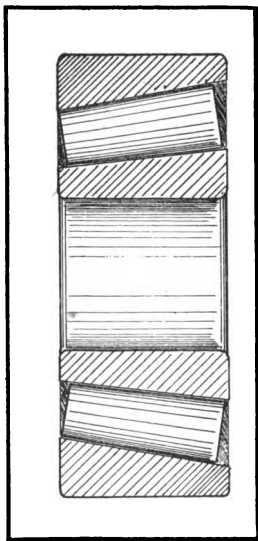

ROLLER BEARING.

A. Flexible roller bearings and straight solid roller bearings are not adjustable. Taper roller bearings and straight rolls having a flange around one end are adjustable by screwing the nut tighter that holds the bearing onto its spindle or shaft.

After placing the bearing parts in place leave them slightly loose and whirl the wheel or part carried by

the bearing and while it whirls turn the nut tighter and tighter. When the tightness prevents easy turning of the bearing bring the nut back just far enough so that the parts turn easily, but without play.

Great care should be used that roller bearings are not made too tight as this will cause them to cut and wear very rapidly.

The nut that holds the roller bearing onto the end of the shaft must be locked in position by an extra nut, pin or a special washer.

T. Roller bearings become loose, broken or worn

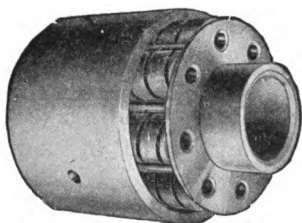

ROLLER BEARING WITH INNER AND OUTER SLEEVES OR RACES.

from several causes. These include wrong or insufficient lubrication, too tight adjustment, not being a proper fit for the shaft or housing, or from being dirty.

Roller bearings usually have felt packing washers at one or both sides for the purpose of preventing leakage of oil or grease. These washers are held in place by metal rings that keep the felt tightly around the shaft and against the housing. New washers should be used or the old ones should be washed in gasoline. Two or more washers may be required if the space is large enough to take them.

BRAKES.

D. Brakes are of two general types. Each type acts on a steel rim or drum fastened to the spokes or hub of the road wheels or to the drive shaft. An "External Contracting" brake is formed by a thin metal band extending around the outside of the drum with levers arranged to draw the band tight enough to stop the motion of the drum. An "Internal Expanding" brake is formed by a shoe or two shoes inside the drum. By a cam or lever arrangement these shoes are pushed apart, exerting enough pressure on the drum to stop its rotating.

Both external and internal brakes are usually faced with an asbestos fabric called brake lining. The internal brakes are often formed of plain cast iron shoes without the lining.

One of the brakes, outside or inside, is connected to the foot pedal and is called the service brake; the other brake being operated by the hand lever and called the emergency brake.

C. Both brakes should be kept properly adjusted and free of dirt, oil or grease at all times.

A. To adjust either type of brake, the rod that pulls the brake is usually made with one clevis or yoke end threaded onto the rod. By removing the clevis pin and screwing the clevis onto or off the rod the brakes may be tightened or loosened. Many other forms of adjustment are provided, all designed to draw the band tighter or expand the shoes more while the

pedal or hand lever remains at the same position. These adjustments are usually operated by some form of screw or nut which draws the ends of the bands tighter and closer or expands the shoes closer to the drum. To properly adjust brakes—

1st—Jack both rear wheels clear of the floor and place the car on solid blocking. Start the engine, and with the gears in low speed let the clutch in.

2nd—Apply the brake to be adjusted very slowly and notice which wheel stops first.

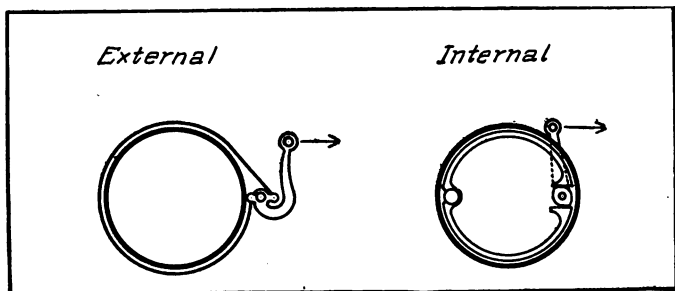

EXTERNAL AND INTERNAL BRAKE DESIGN.

3rd—The brake that was operated (outside or inside) should be tightened on the wheel that stopped LAST and the test repeated until both wheels stop practically at the same time.

4th—Place the gears in second speed and with the clutch engaged open the throttle slowly while applying the brake harder and harder. As you apply the brake open the throttle more and more until it is wide open. The brakes should be strong enough to stop the engine with the throttle wide open.

5th—After tightening the brakes sufficiently, stop

the engine and place the gears in neutral. The wheels should now turn easily by hand without resistance from the brakes.

If the brakes cannot be made to hold according to the above without dragging when released they need relining or else are greasy or dirty or the operating parts are loose or binding.

The brakes should never be applied suddenly or hard enough to slide the wheels on the road. A car will not stop as quick with the wheels sliding as with them turning.



BRAKE OR CONTROL PULL RODS.

Showing the clevis ends with their pins, these ends screwing onto or off from the rods giving adjustment for length. The length may also be adjusted by the turnbuckle on the upper rod.

T. To Replace Worn Facings on Brake Bands or Shoes—

1st—Remove all the old lining by cutting off the rivets with a chisel.

2nd—Secure the necessary length of new lining of the same width and thickness as the old lining. In case the drum shows excessive wear and is quite thin, lining $\frac{1}{16}$ th of an inch thicker may be used. Also secure enough copper rivets to fill each of the old holes.

3rd—Hold one end of the new lining at the end of the shoe or band and drill through for the first two or three rivets, but do not cut the lining off yet.

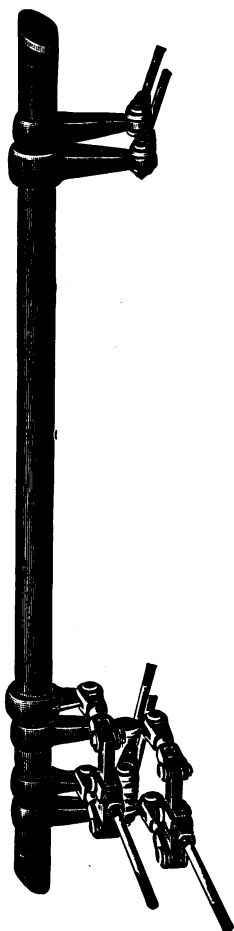

BRAKE EQUALIZERS.

Showing (at the left) the service brake rod and emergency brake rod coming from the pedal and hand lever respectively, these rods fastening to the short cross equalizing bars. The cross shaft is made up of an inside and outside tube, the service brake levers being fastened to one and the emergency brake levers to the other.

4th—Select a drill of the same diameter as the head of the rivets and grind it until the point is almost flat. With this drill cut about half way through the lining at the rivet holes so that the head of the rivet can sink below the surface of the lining.

5th—Place the end of the lining back on the band or shoe and push the first two or three rivets into place but do not fasten them. Now pull the lining tightly into place and with a prick punch mark the rest of the holes for rivets.

6th—Drill and countersink the balance of the rivet holes, rivet the lining in place and cut it off the proper length with a hack saw.

To Remove Grease from Asbestos Brake Lining—

1st—Remove the band or shoe from the wheel and hold it in the vise.

2nd—Direct the flame from a gasoline or acetylene torch onto the lining until all the grease is burned out and there is no more yellow flame.

All brake operating parts should move freely without binding. However, they should not be so loose that the play prevents the brakes from taking hold properly.

CAMS.

D. Cams are circular pieces of metal having one side higher than the other and which in turning on a shaft bring the high side around once every revolution.

In modern engines the cams are usually made in

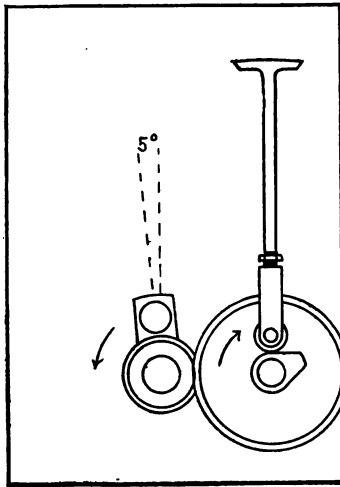

CAM AND VALVE OPENING MECHANISM.

one piece with the cam shaft and are said to be integral with the shaft. That part of the shaft that fits into the bearings is made larger round than the highest point on any cam so that the whole shaft with its cams may be put in place endwise through the bear-

ings. In older types the cams are separate pieces fastened to the shaft with taper pins or keys.

A cam mounted on a shaft and having a rod or wheel or roller resting on it will move the rod, wheel or roller every time the cam turns, the amount of movement being controlled by the shape of the cam.

Cams are mounted on a cam shaft and are used to open the valves of a poppet valve engine.

A. Cams are fastened to the shaft in such a position that they open the valves and allow them to close at just the right time. This work is done at the engine factory and cannot be altered in the repair shop. The valve timing is changed by moving the timing gears.

T. A cam loose on the shaft causes a loud knocking noise. New keys or keyways or both must be made and fitted or the pin holes must be reamed to a larger size and new pins driven in tight.

Should the surface of the cam become worn or rough or flat in places the wear will continue rapidly until it produces loss of engine power and possibly noise. It is then necessary to have new cams and probably new parts against which the cams work.

Cam Shaft. D. The cam shaft is mounted in bearings carried by the crank case in the upper part and is made to turn once for every two revolutions of the crank shaft by the timing gears.

A. The cam shaft is usually carried in plain bronze, brass or babbitt bearings but may be carried by annular ball or roller bearings. Looseness of these bearings causes a loud pounding noise. The cam shaft must be removed to adjust them.

To remove the cam shaft and bearings—

1st—Take off or release all valve springs.

2d—Bronze, brass, annular or roller bearings are held from endwise movement by set screws or bolts passing through the crank case from the outside and holding the bearing or bearing housing in place. These screws or bolts must all be located and removed. Annular or roller bearings are sometimes held by covers or holders that screw or bolt to the crank case at the ends of the cam shaft. Bearings may also be held by collars threaded into the case at each side of the bearing. Sometimes all the bearings come out on the shaft, in other cases one or all the bearings remain in the case.

In cheap constructions the cam shaft may be held in babbitt bearings which are poured around the shaft while it is in place. These bearings must be melted out with a gasoline or acetylene torch to remove the shaft or replace or adjust the bearings.

3rd—To adjust the bearings see the instructions under Bearings.

If the cam shaft bearings are out of line, that is, if their centers are not in the same straight line, the bearings will quickly work loose, causing a knocking noise. Cam shaft bearings must be placed so that they hold the shaft without looseness, yet so that it may be turned by hand with the timing gear.

A bent cam shaft will cause rapid wear on the bearings and knocking and irregular engine operation. It may be tested by removing and placing between lathe centers. To straighten a cam shaft requires experience and suitable machinery.

CARBURETOR.

D. A carburetor is a device that turns the liquid gasoline into a gas or vapor and then mixes this vapor with enough air to make a suitable mixture for burning in the cylinder of the gasoline engine.

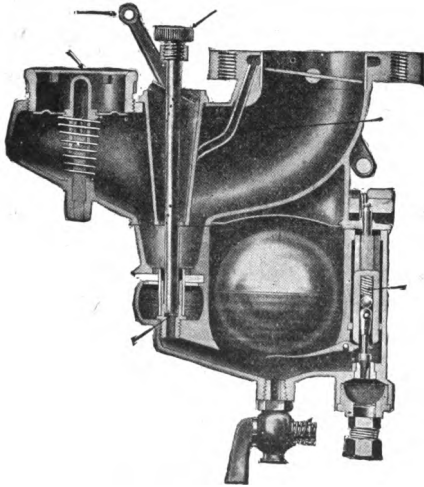

CARTER CARBURETOR.

Showing ball-shaped metal float and form of nozzle with small holes arranged in a spiral around a vertical tube.

Every form of carburetor now in use has certain parts which are described below—

Nozzle, a small pipe, or a pipe having a small opening, which brings the liquid gasoline into the carburetor and from the end of which the liquid comes in a fine stream as it turns to vapor and mixes with air.

Mixing Chamber, the tube which surrounds the nozzle and carries a stream of air past the opening of the nozzle. This air rushes past the nozzle so fast that the gasoline is drawn from the end of the nozzle in a fine spray. One end of the mixing chamber opens to the outside air and is called the primary air intake, the other end of the mixing chamber leads to the inlet pipe which goes to the cylinders through the inlet valves.

Auxiliary Air Intake. After the gasoline vapor is mixed with the air that comes through the primary air intake there will not be enough air in the mixture for high speeds. More air is allowed to enter the mixture above the nozzle through a valve called the auxiliary air valve. Between the gasoline tank and the nozzle the liquid gasoline passes through a compartment of the carburetor called the float chamber. Inside the float chamber is a piece of cork or a hollow metal piece and as the gasoline comes from the tank and rises in the float chamber this float is carried higher and higher. To the float is attached a lever and this lever operates a valve in the pipe coming from the tank. When the float reaches a certain height the float valve closes and prevents any more gasoline from entering the carburetor. When the gasoline is high enough in the float chamber to close the float valve the liquid has risen in the nozzle to a point $\frac{1}{16}$ to $\frac{1}{8}$ inch below the nozzle opening. This point is called the float level of that carburetor. Between the carburetor and inlet valves of the engine is a valve controlled by the driver for admitting more or less of the mixture to the engine, this valve being called the throttle valve.

Some carburetors are made with the float chamber in the form of a ring around the mixing chamber and nozzle. The float is then in the shape of a horse shoe or hollow ring. This is called a concentric float and this type of carburetor may be mounted in any position or turned any direction inasmuch as the level of the gasoline at the nozzle is always maintained at the same point by the float surrounding the nozzle.

The float chamber may be located at one side of the mixing chamber, in which case the float chamber should be toward the front of the car so that the gasoline will remain in the nozzle while going up hill and will lower only when going down hill. This precaution is not really essential in well designed modern carburetors but was observed in many cases.

C. The float chamber and nozzle of the carburetor should be kept clean and free of grit or foreign matter as anything passing up into the nozzle opening will stop the flow of gasoline.

All joints in and around the carburetor and the piping carrying the liquid gasoline and the mixture after it leaves the carburetor should be made perfectly air and gas tight and should be kept this way at all times.

A. Carburetors are adjusted to make a suitable mixture under varying conditions by changing the amount of gasoline or air or of both gasoline and air admitted to the mixing chamber.

The flow of gasoline is changed by a needle valve screwed into or out of the nozzle opening so that more or less liquid is allowed to pass by changing

the size of opening. This needle valve may be adjusted by hand or by being connected to the air valve, throttle valve or other moving part.

The amount of air admitted to the primary air intake is not adjustable in most types, although carburetors are made having means for changing the size of the primary opening. The auxiliary air valve is regulated by nuts or screws which change the tension of the spring attached to the air valve. The air valve is usually adjusted by hand, but in some cases the opening of the air valve is controlled by automatic connection to other parts of the carburetor. The amount of air may be controlled by the weight of steel balls which cover holes in the carburetor wall, by flat springs covering similar holes or by any means for gradually increasing the opening as the speed and suction of the engine increases.

There may be one or more spray nozzles; when there is more than one nozzle the carburetor is said to be a multiple-jet type. In the majority of carburetors of this type only one, or possibly none of the nozzles are adjustable. One of the nozzles is usually used for low engine speeds and others for higher speeds. In case more than one nozzle is adjustable one adjustment would be for low speed, another for high speeds, another might be for intermediate speeds. There is always some automatic means for bringing the proper nozzles into action, such as an increased throttle opening uncovering more nozzles, a valve that opens over a second or third nozzle as the suction increases or any method that will produce substantially the same result.

There may be only one auxiliary air valve or there

may be more than one. Each air valve is usually adjustable separately from the others, one being for low speeds, one for intermediate, one for high, etc.

Standard types of carburetors having a gasoline needle valve and a spring controlled auxiliary air valve are adjusted in practically the same way regardless of the make.

If the carburetor has been taken apart or if you have reason to think that it is badly out of adjustment, see that the level of the gasoline in the nozzle is about one-sixteenth of an inch below the opening. This must be tested by looking at the end of the nozzle with the carburetor sufficiently disassembled to permit this, yet in such condition that gasoline may be admitted through the regular inlet pipe and through the float valve, allowing the float and float valve to shut off the flow at the correct time. This may necessitate removing the carburetor from the car and placing it on the work bench, admitting gasoline through a rubber tube slipped over the end of the gasoline inlet pipe. The other end of this tube may be slipped over the lower end of a small funnel held at some distance above the carburetor while making the test.

Close the needle valve reasonably tight so that it seats, but do not damage the valve or seat by excessive force. Then open the needle valve from three-quarters to one and one-quarter full turns.

See that the tension on the auxiliary air valve spring is just enough to hold the valve firmly on its seat.

Retard the spark lever, if there is one, and open the throttle about one quarter. Turn on the switch and start the engine.

Slowly close the throttle until the engine seems

about ready to stop. Then open or close the needle valve until the engine runs faster again without changing the throttle opening. Close the throttle a little more and keep turning the needle valve one way or the other until the engine runs as slow as it will run without stopping and with the throttle as far closed as possible.

Set the throttle stop screws and the carburetor is adjusted for low speed ready for the road test.

To adjust high speed advance the spark lever, if there is one, about two-thirds of the way and open the throttle wide for a second or two to see if the engine speeds up. Do not keep the throttle open and allow the engine to run fast, or "race," but for a few seconds—just long enough to notice the action. If there is no spitting noise from the carburetor, open the air valve more and more until there is this noise when the throttle is suddenly opened, then close the air valve by increasing the spring tension just enough to prevent this spitting. Lock the air valve in this position if there are means provided for locking.

Too rich a mixture causes the following (too rich means either too much gasoline or too little air in the mixture)—

1. Galloping—one explosion missed every second cycle of operations.
2. Flooding after the engine stops.
3. Strong smell from the exhaust.
4. Overheating.
5. Loss of power.
6. Black smoke from the exhaust.
7. Red exhaust flame when the exhaust manifold is removed.

Too thin a mixture causes the following (too thin means either too little gasoline or too much air in the mixture)—

1. Spitting noise from the carburetor.
2. Popping noise.
3. Hard starting.
4. Missing explosions.
5. Loss of power.
6. Yellow exhaust flame when the exhaust manifold is removed.

The correct mixture has none of the above symptoms and gives a purple exhaust flame when the exhaust manifold is removed from the engine.

To correct a thin mixture open the needle valve more if the trouble is at low engine speeds, close the air valve more if the trouble comes only at high engine speeds or raise the float level if the trouble occurs at all speeds. Raising the float level makes the gasoline stand higher in the nozzle and is accomplished by holding the float valve end of the float lever stationary while the float end of the lever is raised. Some carburetors have screw adjustments on the float valve, or on the spring that resists movement of the float valve.

To correct a rich mixture close the needle valve more if the trouble is at low engine speeds, open the air valve more if the trouble comes only at high speeds or lower the float level if the trouble comes at all engine speeds. Lowering the float level lowers the height of the gasoline in the nozzle and is done by bending the float end of the float valve lever down.

There are three ways of overcoming hard starting—

1. Prime the cylinders by placing about a teaspoon-

ful of liquid gasoline in two or more of the cylinders through the pet cocks, or by taking out the spark plugs.

2. Choke the carburetor by shutting off almost all the air coming through the primary and auxiliary air intakes, thus causing a stronger suction and drawing more gasoline into the mixture. This may be done by closing small shutters or valves in the air intakes, by holding the air valve on its seat by levers or stops provided for this purpose, or by placing the hand or handkerchief over the air intakes.

3. Flood the carburetor by pressing the small lever or pin on top of the float chamber. This pin passes through the wall of the chamber, striking the top of the float and holding it down. This opens the float valve and admits enough gasoline to the nozzle so that a rich mixture is produced.

Breeze Carburetor Adjustment. On top of the Breeze carburetor is a round screw head having numbers around the edge and held in place by a wire that catches in notches around the outside of the screw head. This is the needle valve and is used for adjusting for low engine speeds. At the end of the carburetor and on top is a wing nut that adjusts the tension of the auxiliary air valve spring and this is used for high speeds.

First see that gasoline is in the float chamber by pressing on the small button or lever found on top of the float chamber. This is called a primer, or tickler, and when pressed it holds the float down until the gasoline rises in the chamber and nozzle high enough to overflow the nozzle and drip out below.

Now screw down on the needle valve by turning

it to the right until it turns no farther, thus closing the nozzle opening completely. Now open the needle valve by screwing the other way three quarters of a full turn.

Next loosen the lock nut on the air valve and screw the valve stem up or to the left until the air valve comes up against the seat. This can be tested by poking the air valve with a pencil through the cage that holds it.

Now start the engine, retard the spark and turn the needle valve up or down until the engine runs fastest with the spark retarded and the throttle closed as far as possible without stopping the engine. This adjusts low speed.

Next advance the spark two-thirds of the way and quickly open the throttle and close it. If the engine increased its speed with the throttle opening but did not miss explosions and did not make a spitting noise through the carburetor, screw the air valve stem down more, allowing the valve to leave its seat easier. Quickly open and close the throttle again and keep opening the air valve this way until the engine makes a spitting noise through the carburetor. Then bring the air valve back about a quarter turn to prevent the spitting.

If the spitting occurred the first time the throttle was opened screw the air valve stem farther up or to the left, increasing the spring tension and making it harder for the air valve to leave its seat. The carburetor is now adjusted, ready to take on the road for a test.

When on the road you can repeat the same tests

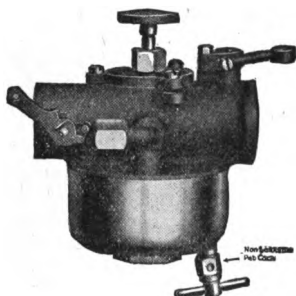

HOLLEY CARBURETOR USED ON FORD AND OTHER LIGHT CARS.
Showing needle valve adjustment on top.

and readjust the carburetor if the action, speed or power of the engine is improved by doing so.

Holley Carburetor Adjustment. The Holley carburetors are made with an adjustable needle valve, but there is no adjustment for either the primary or auxiliary air intakes. It is therefore necessary to adjust the needle valve only. The needle valve is on top of the old style Holley carburetors and on the bottom of the new Holley. It is adjusted in exactly the same way as given in the second, third and fifth paragraphs under Breeze Carburetor Adjustment. If there is a spitting noise when the throttle is quickly opened and closed the needle valve must be opened a little more.

Kingston Carburetor Adjustment. The Kingston carburetor has a needle valve on top of the carburetor for adjusting the gasoline, the auxiliary air is adjusted by five steel balls that close five holes. These balls are underneath the five small nuts seen around the top edge of the carburetor and they are not adjustable in any way. The Kingston carburetor is ad-

MOTOR CAR PARTS

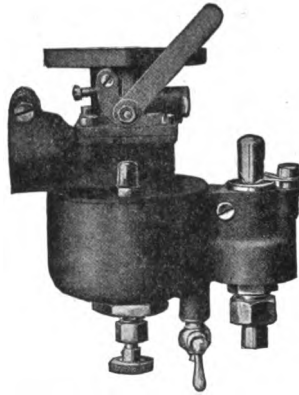

HOLLEY MODEL "H" CARBURETOR.

justed in exactly the same way as directed in paragraphs 2, 3 and 5 under Breeze Carburetor Adjustment. Should the spitting noise occur when the throttle is suddenly opened it will be necessary to open the needle valve a little more.

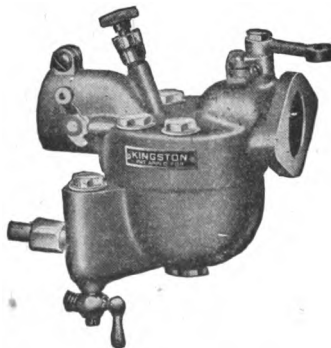

KINGSTON CARBURETOR USED ON FORD CARS.

Showing the gasoline nozzle adjusting screw coming from the top and the throttle valve lever.

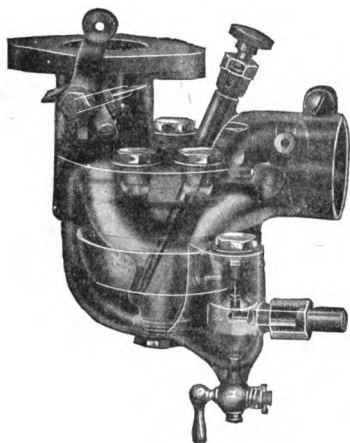

KINGSTON CARBURETOR.

Showing the method of controlling the auxiliary air supply by means of steel balls for valves.

Rayfield Carburetor Adjustment. The model number of the Rayfield carburetor is on the outside of the part between the mixing chamber and the float chamber, on the side of the carburetor and just above the drain cock. Model D has two adjusting screws, both of which control the needle valve opening, and an auxiliary valve controlled by turning a corrugated sleeve which surrounds the air valve. One of the screws for controlling the needle valve is located so it screws against a piece of metal on one end of the throttle shaft, the screw being quite high on the carburetor. This screw adjusts high speeds and is the smaller of the two.

The low speed adjusting screw is below the other one and points the other way, bearing against a cam

MOTOR CAR PARTS

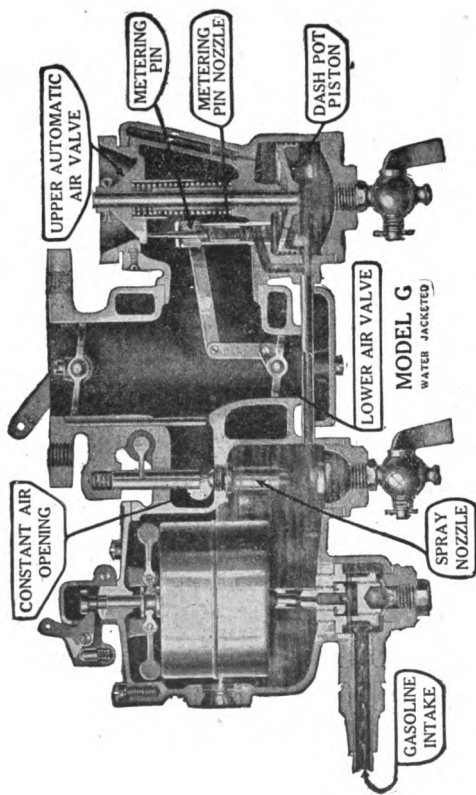

INTERIOR OF THE MODEL G RAYFIELD CARBURETOR.

at the bottom of a short shaft at the outside of the carburetor.

First see that there is gasoline in the float chamber, then see that the plunger on the driver's side of the dash is pushed all the way in. This plunger connects to a wire that moves an arm on the carburetor. The plunger is pulled up or out for easy starting.

Now unscrew or turn to the left the low speed adjustment until the end of the arm just leaves contact with the cam under the high speed screw. Then turn back to the right one and one-half turns. Open the throttle a little ways, retard the spark and start the engine. Gradually close the throttle until the motor is running as slow as it will without stopping. Then turn the low speed screw to the left one notch at a time until the motor runs slowly and smoothly. This makes the low speed adjustment.

Next advance the spark two-thirds of the way and open the throttle wide and close it quickly. If there is a spitting noise from the carburetor turn the high speed screw to the right or screw it in one notch at a time until when you open the throttle there is no spitting. If the spitting does not occur turn the high speed screw to the left until it does spit, then turn it back to the right just far enough to prevent spitting. This makes the high speed adjustment.

If the action is not satisfactory at intermediate speeds between high and low, change the tension of the air valve spring by turning the sleeve a few notches to the right or left.

Models A, B, C, D, E, H, AA, BB, CC, EE, DA—Adjust in the same way as the Model D is adjusted.

Models G and L—Are adjusted in the same way as

MOTOR CAR PARTS

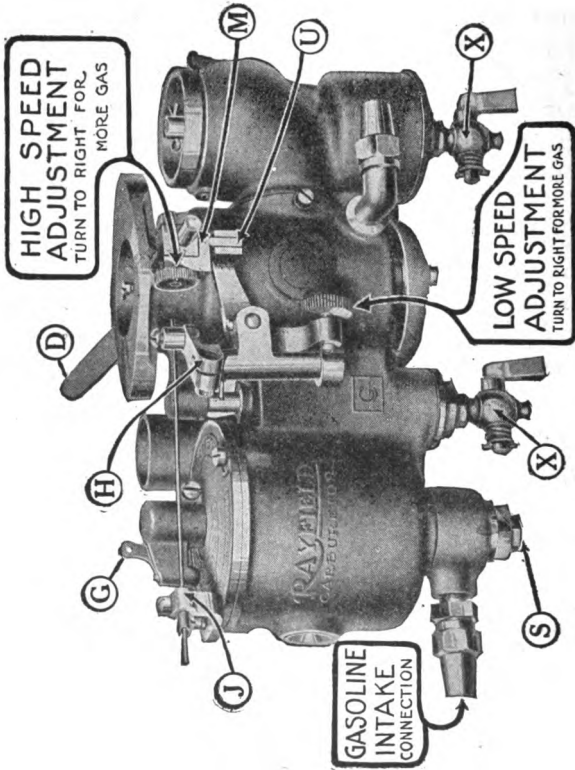

RAYFIELD MODEL G CARBURETOR.

the Model D but there is no air valve adjustment to be made for intermediate speeds.

Schebler Carburetor Adjustment. The old Scheblers, Models D and E, have a needle valve on the lower side of the float chamber which is screwed in or to the right to shut off the gasoline, and turned to the left to give more gasoline. These carburetors also have an adjustable auxiliary air valve in the air intake which is adjusted by releasing the locking nut and

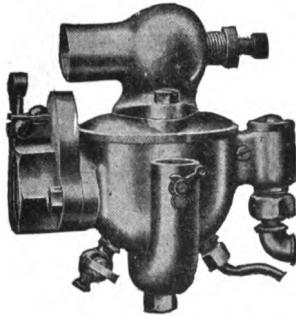

SCHEBLER MODEL E CARBURETOR.

Showing air intake in front, needle valve for low speed adjustment on bottom of carburetors, drain cock from float chamber, throttle at left hand side and air intake with auxiliary air valve on top.

turning the end of the air valve plunger out to the left to give more air and turning it to the right to increase the spring tension and give less air. These carburetors are adjusted by turning the needle valve to the right as far as it will go, then opening it by turning it back about three-quarters of a turn.

Next see that the air valve is seated, open the throttle a little ways, retard the spark and start the engine. Turn the needle valve one way or the other until the motor runs as slow as possible without stopping.

MOTOR CAR PARTS

Next advance the spark two-thirds of the way and quickly open the throttle and close it. If there is a spitting noise the air valve screw must be turned in

MODEL "D"

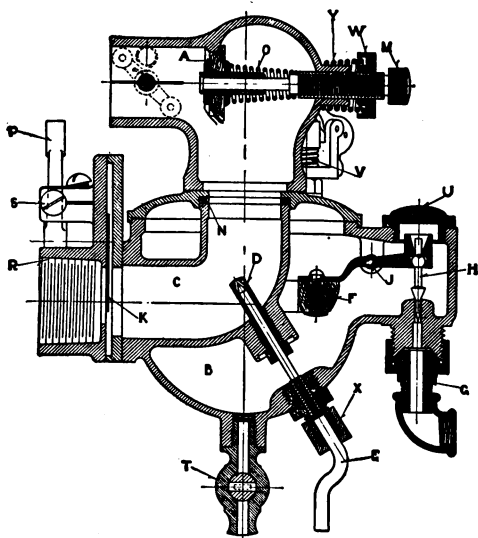

SCHEBLER MODEL D CARBURETOR.

A, Auxiliary air valve; B, Float chamber; C, Mixing chamber; D, Nozzle; E, Needle valve; F, Float; G, Gasoline inlet; H, Float valve; J, Float lever; K, Throttle; M, High speed screw; N, Packing washer; O, Air valve spring; P, Throttle arm; R, Opening to engine; S, Throttle stop screw; T, Drain cock; U, Float valve cover; V, Lever for flooding; W, High speed screw lock nut; X, Needle packing nut; Y, Lock nut spring.

to the right until there is no spitting when the throttle is quickly opened, then turned back about a quarter turn. If there is no spitting the air valve screw must be turned to the left or unscrewed until spitting occurs, then back to the right a quarter turn.

Model H—This carburetor has the needle valve on top and standing at an angle. It should be closed by turning to the right and then opened two turns, the engine started, made to run slowly and smoothly as directed under Model D and E. This low speed adjustment should be set so that the engine runs as fast

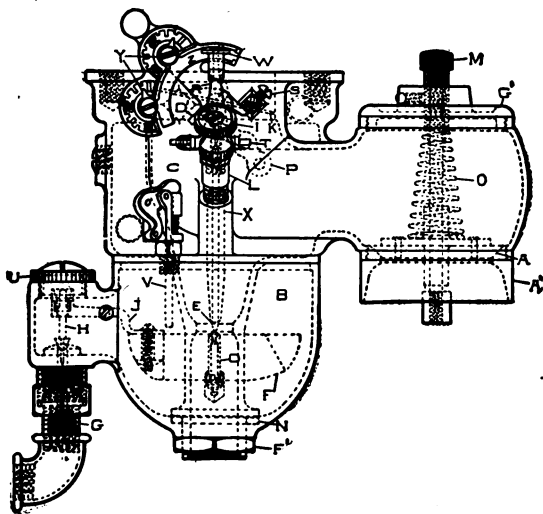

SCHEBLER MODEL L CARBURETOR.

A, Auxiliary air valve; B, Float chamber; C, Lever for flooding; D, Needle valve top; E, Needle valve point; F, Float; G, Gasoline inlet; H, Float valve; I, Throttle stop; J, Float lever; L, Needle valve holder; M, High speed screw; N, Packing washer; O, Air valve spring; P, Throttle lever; S, Throttle stop screw; T, Hinge pin for needle holder; U, Float valve cover; V, Flooding tickler pin; W, Roller on needle valve holder arm; X, Needle valve; Y, Pointers and dials for adjustment.

as possible with the throttle nearly closed, the throttle being closed more and more until adjusting the needle valve will no longer prevent the engine from stopping.

On top of the Model H you will find a little pointer which can be set at numbers 1, 2 or 3 on a small dial.

This is the high speed adjustment. After making the motor run slowly and evenly with the needle valve advance the spark two-thirds and open the throttle quickly. If there is spitting turn the small pointer farther toward number 3 end of the dial until spitting just stops. If there is no spitting move the pointer toward number 1 on the dial until spitting occurs, then back just enough to prevent spitting. The air requires no adjustment.

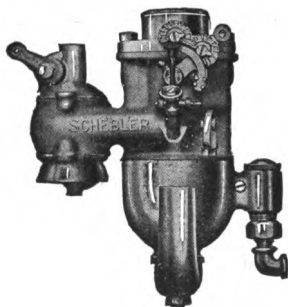

SCHEBLER MODEL L CARBURETOR.

Showing primary air intake through curved tube into bottom, needle valve for low speed adjustment and pointers and dials for intermediate and high speed gasoline adjustment. At the left side is the auxiliary air valve with small lever for increasing or decreasing the tension of the valve spring from the driver's seat.

Model L—Has the needle valve just like the Model H and on the part that moves with the throttle are two small pointers moving over two dials, each dial being numbered from one to three. Adjustment is made just the same as for the Model H except that the right hand pointer and dial is for adjusting the intermediate speeds with the throttle half open and the left hand pointer and dial adjusts the high speed.

Model O—Is adjusted just the same as the Model H,

but the small pointer and dial is located on an arm that moves with the throttle in place of on top of the carburetor.

Model R. Has two adjustments, one being a sleeve or cage on top of the auxiliary air valve which is the low speed adjustment; the other being a small screw head below the auxiliary air valve which adjusts high speeds. The upper adjustment controls the needle valve in the nozzle, the lower adjustment controls the tension on the air valve spring.

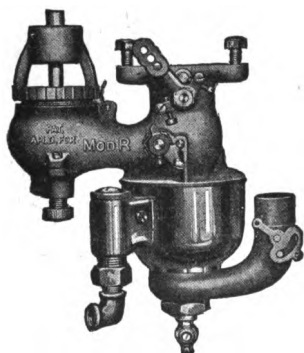

SCHEBLER MODEL R CARBURETOR.

Showing primary air intake through curved tube and auxiliary air valve at the left side. The low speed adjustment is on top of the auxiliary air valve and the high speed adjusting screw is seen below the air valve.

To adjust the carburetor first see that there is gasoline in the float chamber, then turn the upper low speed adjustment to the right until it stops, then back to the left one full turn. Now retard the spark, open the throttle a little ways, start the engine and turn the upper adjustment to the right or left until the engine runs best with the throttle just as far closed as it will go without stopping the engine. This makes the low speed adjustment.

MOTOR CAR PARTS

Next advance the spark two-thirds of the way and open the throttle quickly. If there is a spitting noise in the carburetor turn the lower or high speed adjusting screw up or to the right until the spitting just stops. If there is no spitting turn the screw down to the left or unscrew it until spitting occurs, then turn the screw back about one-quarter turn. This makes the high speed adjustment.

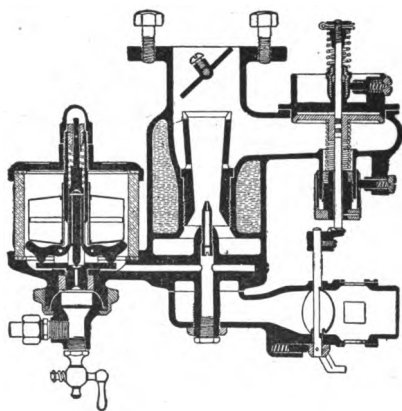

STROMBERG CARBURETOR—TYPE "A."

Stromberg Carburetor Adjustment. Stromberg carburetors are adjusted by the air valve, this valve being mounted or balanced between two springs, one spring being for low speeds and the other for high speeds. The nozzles for Stromberg carburetors may be removed and replaced by taking out the plug or drain cock at the bottom of the mixing chamber, draining the gasoline from the carburetor. After this plug is out stick

Push a long thin screwdriver up into this hole until it will go no farther. This screwdriver will then be in the slot of the small nozzle tip, and by holding the screwdriver tight up against the nozzle and turning it to the left or unscrewing it the nozzle will unscrew and drop down out of the hole. On the sides of these nozzles are numbers 56, 57, etc., up into the sixties. The higher the number on the nozzle the smaller the opening in the end will be.

After adjusting a carburetor as directed below if you find that the air valve does not touch the seat with the engine stopped, then the nozzle is too large and a nozzle of the next larger number must be tried. If you find that the upper high speed adjusting spring has no play and is touching the air valve and nut when the engine is stopped the nozzle is too small and one of a smaller number should be substituted.

After selecting the proper nozzle for a car it should never be changed.

Models A, B, and G. See that there is gasoline in the glass float chamber, then take hold of the small stiff spring on top of the auxiliary air valve and make sure that you can move it up and down freely for at least one thirty-second inch, that is, see that this spring has a little play up and down and that it does not touch the air valve and the nut on top of the stem at the same time. If this spring is tight turn the nut at the bottom of the spring down or to the right until there is sufficient play.

Next turn the small round sleeve on the bottom of the air valve stem down or unscrew it until the air valve drops down from the seat, then screw it up until

MOTOR CAR PARTS

the valve just touches the seat and then up about three notches more.

Now retard the spark and open the throttle a little ways and start the engine. Turn the lower sleeve up or down a notch at a time until the motor runs as slow as possible and with the throttle closed just as far as it will go without stopping the engine. That is, keep closing the throttle until the engine is ready to stop, no matter which way you turn the low speed adjusting sleeve. This is the low speed adjustment.

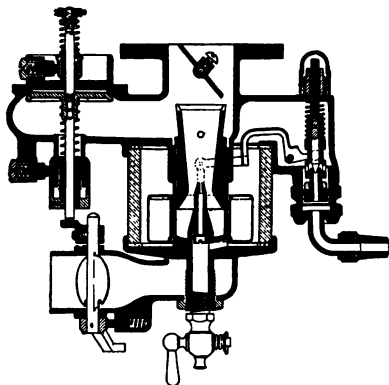

STROMBERG CARBURETOR—TYPE "B."

Next advance the spark two-thirds of the way and quickly open and close the throttle. Should there be a spitting noise in the carburetor turn the small nut at the bottom of the high speed spring on top of the valve up a little at a time until there is no spitting when the throttle is suddenly opened. If there is no spitting on the first trial screw this small nut down, loosening the spring, until there is spitting, then back about one notch. This is the high speed adjustment.

Model C. Is adjusted the same as A and B except that the high speed adjusting nut is at the very top of the air valve stem. Just under this nut is the end of a small lever. When the nut is drawn down by the air valve's opening this lever is pulled down, opening another jet or spray nozzle for high speed. Before adjusting Model C make sure that the high speed nut on the

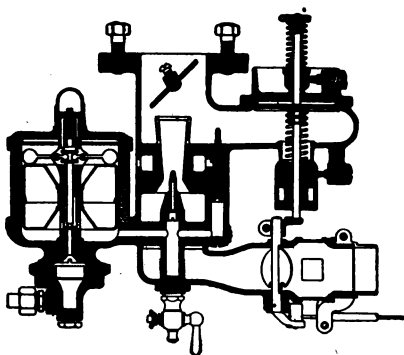

STROMBERG CARBURETOR—TYPE "G."
Secondary gasoline jet in auxiliary air intake.

top of the valve stem does not touch the small lever by at least one thirty-second inch by screwing the nut up if necessary.

In adjusting high speed screw this high speed nut down to prevent spitting and screw it up to cause spitting.

Model D. Is adjusted in the same way as the Model C with the exception that the lower or low speed adjustment is made at the factory and should not need changing. The low speed is not adjusted by a notched sleeve but by a screw head with a locking nut. If the air valve

is off its seat with the motor running light at low speeds you should turn this low speed adjusting screw up until the valve does seat.

This carburetor has a shutter around the air valve that can be opened or closed from the driver's seat by a wire. For ordinary running this shutter should be three-quarters of the way open. If the shutter has to be closed more than one-half way to go fast, the second

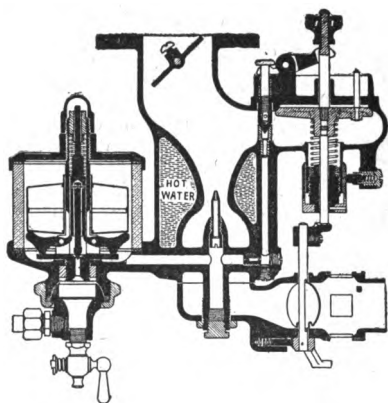

STROMBERG CARBURETOR—TYPE "C."
Showing secondary gasoline jet operated by air valve.

nozzle, which is operated by the small lever from the top of the air valve stem, is too small and a larger one is needed. If this shutter has to be fully opened to make the motor run smoothly without missing occasional explosions the second jet or nozzle is too large.

Models H and HA. These types have the air valve adjustments above the valve, on the side opposite the float chamber. The top adjusting nut handles the high speed and the lower adjusting nut (just above the air

valve) is for low speed work. There is a wire running to the dash which makes the mixture richer in gasoline when it is pulled up or away from the carburetor. Turning either adjustment to the right or clockwise or down gives less air or more gasoline; turning either adjustment up or to the left gives more air or less gasoline in the mixture.

In starting to adjust these types first set the high speed adjusting nut so that there is at least one thirty-second inch clearance between it and the brass collar below it, with the air valve on its seat. To turn the high speed nut it must be first lifted to release the locking pin. Also see that the rocker arm moved by the dash adjustment does not touch the collar above it. The air valve must just touch its seat; this may be accomplished by turning the low speed adjusting nut.

To start the motor pull the dash adjustment all the way up and if necessary close the valve in the lower air inlet. Let the motor warm up before proceeding with the adjustment.

After the motor starts and runs until warm, adjust the low speed nut to give more and more air until the engine runs as fast as possible with the throttle closed as far as possible. To adjust the high speed, advance the spark two-thirds of its travel and open and close the throttle quickly. Turn the high speed nut up, giving more and more air until there is a spitting noise when the throttle is opened and then turn it back far enough to prevent this spitting. After completing the adjustment there must be clearance between the high speed nut and the collar below it.

Model K. This is a concentric float type with but

one adjustment, this being a nut for controlling the air valve and placed directly over the air valve.

To adjust the carburetor turn the nut up to the left or anti-clockwise until the air valve leaves its seat (when pulling upon the adjusting nut there is a click heard if the valve is off its seat). Now turn the adjustment the other way until the valve just seats and the click disappears, and then turn it two more notches in this same direction. Turning this adjustment up to the left or anti-clockwise gives less gasoline or more air.

Zenith Carburetor Adjustment. The Zenith carburetor has no outside adjustments, and, except in unusual cases or from long use, will not need adjustment.

It is a double jet instrument, one jet being in the center of the mixing chamber and the other opening into the wall of the mixing chamber at a point where it is covered when the throttle is completely closed by the throttle valve touching and covering the opening in the chamber wall.

The flow of air through the mixing chamber is regulated by a removable tapered tube that surrounds the nozzle and is called the "choke tube." There are no auxiliary air valves or spring controlled valves of any kind.

The nozzle may be changed in size by taking the carburetor apart and substituting a new nozzle. In the tube between the float chamber and the mixing chamber is a brass tube with a small hole in one end called the "well." Changing this well for one having a larger or smaller opening will affect the

adjustment for idling or picking up. Any of these changes make it necessary to send to the maker for new parts.

All carburetors have small screws placed somewhere around the throttle, at one side or the other, which are for the purpose of allowing the throttle to close more when they are unscrewed or for holding the throttle wider open by screwing the screws farther in. These screws are provided with locking nuts or other smaller screws that may be tightened against the main adjusting screw. These "throttle stops" should be used to make the engine slow down by closing the throttle more and more, but when a point is reached at which further closing of the throttle would stop the engine, then the throttle stop screw should be set and locked in this position.

Before deciding that a carburetor needs adjustment make sure that none of the following faults are present:

No gasoline in tank or in float chamber.

Leaks in the inlet manifold or carburetor or cylinder flanges.

Dirt in the nozzle or under the float valve.

Punctured metal float or gasoline soaked cork float.

No spark.

Leaking compression in cylinders.

No cooling water or not enough oil.

Water in gasoline and in carburetor.

R. In reassembling a carburetor notice the following things: See that the nozzle is open through into the float chamber by blowing through a rubber tube slipped over the nozzle. See that the throttle is tight on the shaft that works it. See that the air valve is

not binding or sticking and that its spring is not broken or bent or flattened. See that the needle valve screws in and out so that it can close the nozzle. Make sure that a metal float has no holes or gasoline in it and that a cork float is dry and does not need a new coat of shellac. As the parts are put together make sure that every joint is made air and gas and gasoline tight either by paper and shellac gaskets, copper-asbestos gaskets, or perfectly fitting ground joints.

T. A common trouble that affects the carburetor is an air leak in the piping from the mixing chamber to the engine. It will be impossible to adjust a carburetor with a leak of this kind. See under Inlet Manifold.

If an engine has not good compression the carburetor is very hard to adjust and the adjustment will not be satisfactory. Test the compression by pouring oil around all joints and threads and then turning the crank and watching for bubbles. Also look at the valves and piston rings for compression.

TROUBLES THAT MAKE A THIN MIXTURE.

1. Water in the carburetor. Drain the carburetor. Causes the same thing to happen as a thin mixture.
2. Shut off valve partly or entirely closed. Open.
3. Piping clogged with dirt. Take the pipe off and blow through from the carburetor end of the pipe.
4. Dirt in the float chamber or in the float valve. Take the carburetor apart and clean.
5. Air leaks around the inlet manifold, spark plugs, valve caps or carburetor flange.
6. Gaskets must be made tight. Test by pouring

oil on the joints and watch to see if it is sucked in out of sight.

7. Broken air valve spring. New spring. If on the road, put a plug or wire on the valve to hold it closed.

8. Gasoline tank cap has no hole or vent in gravity feed system. Gasoline can't flow out unless air can flow in.

9. Leaks in gasoline tank or piping with pressure feed system. Close up the leaks.

10. Air valve loose. Should be properly adjusted.

11. Float sticking. Jar the carburetor to loosen it.

12. Air valve stem binding. Make a free moving fit by filing or use emery.

13. Piece of something in gasoline tank. Will not let the gasoline flow freely when it gets over opening to pipe.

14. Air lock in gasoline pipe. Caused by having the pipe turning upward and then downward again, or from having the pipe too close to the exhaust piping.

15. Water lock in gasoline pipe. Caused by having the pipe turn downward and then upward again.

16. Pipe bent or cracked. Should have new pipe but may be soldered.

17. Pressure pump valves not seating. Should be thoroughly cleaned or ground in.

18. Pressure pump screen dirty. Wash with gasoline and brush.

19. Auxiliary dash tank float sticking, punctured or soaked. May be jarred loose, dried out and shellaced if of cork, or warmed and soldered if metal.

20. Loose throttle bearings. Must be bushed (in old carburetor only).

21. Water gets into mixing chamber. Leaking hot water jacket.

TROUBLES THAT MAKE A RICH MIXTURE.

1. Float sticking. Carburetor floods. Jar with hammer handle.

2. Dirt under needle or float valve. Carburetor floods. Jar. (Should be cleaned.)

3. Fuel level too high. Lower the float level.

4. Air valve screwed down too tight. Loosen and adjust.

5. Needle valve too far open. Close.

6. Float valve parts loose. Take apart and tighten.

7. Shoulder worn on needle valve. Must be dressed down with fine file or grind on its seat with powdered glass and thin oil.

8. Cork float gasoline soaked. Dry in warm room, then shellac and dry.

9. Metal float punctured. Drive gasoline out of float by placing in a basin of hot water, or as warm a place as possible away from a flame. Locate the hole, solder and remove all extra solder.

Every possible carburetor trouble must make the mixture either too thin or too rich. First find which way the mixture is wrong and then look up the troubles in the order given.

After a gasoline engine is running much more air can be added to the mixture. This extra air gives more power with less gasoline and keeps the engine in better condition for hard and fast work. After adding this air, should the engine be stopped it could not easily be started again without cutting off the extra air supply. To secure the advantages of this

extra air there are many forms of valves, either hand operated or spring controlled, and arranged so that they add air to the mixture after it leaves the carburetor by being attached in the inlet manifold. An extra air inlet can be easily attached by boring and threading a hole in the inlet manifold above the carburetor and before it branches to go to the different cylinders. Into this hole screw an ordinary pet cock with the longest handle possible to find. Bore a hole in this handle and run a rod or stiff wire up to the steering column so that the driver can open or close the valve while running. Before stopping the engine this valve should be closed so that the engine will start easily. When the car speed becomes low in regular driving this valve should be closed or when the throttle is opened the engine will stop.

Heating. The poor grade of gasoline now in use makes it very desirable to heat the air that passes into the carburetor or else heat the walls of the mixing chamber or of the inlet piping. This may be done with exhaust gas, hot water, hot air, manifold heating or electric heating plugs.

Exhaust gas from the engine may be used to heat the carburetor. Most carburetors are now made with a hollow jacket around the mixing chamber something like the water jacket around the cylinders. This jacket has two openings threaded one-eighth or one-fourth inch pipe thread. To provide heat from the exhaust it is necessary to drill a hole in the exhaust manifold and thread it the same size as the holes in the carburetor jacket. With tubing fittings connect this exhaust pipe opening to one of the openings in the carburetor jacket, using copper tubing. To the

remaining opening in the carburetor jacket fit a length of copper tubing to lead the gas outside the pan on account of the possibility of sparks from the exhaust. It is customary to fasten a pet cock into the exhaust manifold hole and then fasten the tubing to this pet cock so that heat can be turned off in very hot weather.

Hot water heating gives a more even heat than the

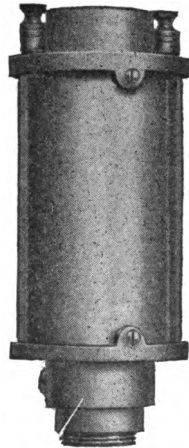

ELECTRIC HEATER TO BE PLACED IN PIPING TO CARBURETOR
PRIMARY AIR INTAKE, HEATING THE AIR FOR
EASY STARTING.

exhaust gas but is harder to apply. The same jacket on the carburetor is used for either method. To attach hot water heating; bore and tap a hole into any water pipe leading from the cylinders to the top of the radiator and run a copper tube of the largest possible size from this opening to the hole in the carburetor jacket that is highest up. Next bore and tap a hole in the pipe coming from the bottom of the radiator

or else tap into the lower part of the radiator itself. From this opening run another copper pipe to the hole in the carburetor that is lowest down. Place a pet cock in one or both of these pipes so that the heat may be turned off and so that the carburetor may be removed without waiting to drain all the water.

Hot air heating furnishes warmed air to the air intake of the carburetor but does not heat the mixing chamber as either hot water or exhaust gas does. Hot air heating may be used on any carburetor, with or

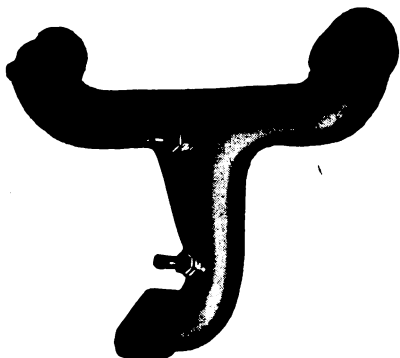

ELECTRIC HEATING PLUG INSERTED IN INLET PIPING.

without a jacket, and it is sometimes used in connection with one of the other systems. To make the necessary connections first make or buy a sheet metal hood or loose clamp that will draw hot air from around the exhaust pipe into a tube or pipe that leads to the primary air intake of the carburetor. Fasten this hood firmly around the exhaust pipe but set away from the surface of the pipe about one-half inch and run copper or brass tubing or flexible tubing to the lower or primary air intake on the carburetor.

Manifold heating is furnished on some cars where the intake manifold runs through between the cylinder castings or else the manifold runs in such a way that all or part of it will be surrounded with hot water. This must be designed in the car and cannot be applied in the shop.

Electric heating plugs are now made to screw into a hole threaded into the manifold above the carburetor. The inner end of this plug has wires arranged to become very hot when electric current from the storage battery is switched into the plug. The mixture striking this hot plug is heated and made easier to burn. These plugs are used principally for easy starting.

CHAINS, DRIVING.

D. Driving chains are of three forms, roller, silent and block. Roller chains are made with pins passing from side to side into short pieces of steel, each pin forming a hinge so that the chain can turn around the sprocket. These pins have a hardened steel, hollow roller around them so that the roller takes the wear of the sprocket and allows the turning to come between the roller and pin. This type is used for driving the car and for almost every other use around the car where chain drive is required.

Silent chains are made of a great many V-shaped pieces placed side by side and pinned with a pin passing through each of them. Two pins pass through the upper part of the V, each pin passing through alternate pieces. In use, this type of chain has the property of filling the space between the sprocket teeth entirely, making the operation quite noiseless. A silent chain also compensates for wear to a certain extent. This type is used for driving cam shafts, magneto shafts, electric lighting dynamos, electric starting motors, etc.

Block chains are made with solid steel blocks shaped to fit between the teeth of the sprocket and pinned together by flat pieces on the outside of the blocks. Block chains are very little used at present except for the lightest work.

C. Chains should be kept properly adjusted and should be cleaned and oiled every 500 miles when they run in the open air.

To clean and oil the chain, first wash it thoroughly in kerosene and hang it up until dry. Now prepare a mixture of tallow and powdered graphite, heated until the graphite can be stirred into the tallow in the proportion of one-half pound of graphite to two pounds of tallow. Dip the chain into this hot mixture and keep hot until the chain is well soaked with the grease. Lift the chain out of the grease and allow the grease to drip back into the pan. As the chain cools wipe the excess grease off with a cloth. The chain is then ready for use.

Should it be impossible to lubricate as given above the chain may be wiped off with a cloth and a special grease, bought as chain compound or chain grease, may be rubbed on the inside of the chain where it touches the sprocket.

A. There should always be some means of lengthening the distance between the chain sprockets to take up the stretch of the chain due to wear. In adjusting chains tighten them by setting the sprockets farther apart until the loose side of the chain can be lifted up and down about one inch for each eighteen inches between sprockets.

When the sprockets have been separated as much as possible and the chain is still loose, the chain itself may be shortened by removing a link. To do this remove one of the short side pieces which may be held in place by cotter pins, or by a hole and slot in the piece which must be moved endwise of the chain, or by being riveted. The link that comes apart on a chain is usually marked by having the side piece of a special or different shape from the others. After taking off the side piece the pins may be drawn out from the other

side, carrying the opposite side piece with them. The loose ends should then be hooked back together and fastened as before.

Removing one link shortens the chain twice the distance between two sprocket teeth. If this is too much change a "half link" may be bought. This is made with one end to go over the outside of one of the rollers, the other end going inside the side pieces. This form of link shortens the chain the distance between one tooth and the next one.

R. In placing a chain on its sprockets it is easiest if the chain is passed over each of the sprockets, leaving the loose ends on top. By turning one of the sprockets while the other one is stationary the ends of the chain may be brought near enough to fasten.

Always place a chain so that the removable link or side of the links is on the outside where it may be easily reached.

T. Should one chain break on a double chain drive car you can proceed with one chain by fastening the other driving sprocket so that it cannot turn. This may be done with part of the old chain or wire or rope. The car will then run twice as fast on the remaining chain due to the action of the differential.

To detect a worn chain remove it from the sprockets and try to bend it sidewise. It should not bend much more than $\frac{3}{4}$ of an inch to the foot of length. The only remedy for worn chains is new ones.

A worn sprocket that has the teeth cup shaped on the driving side may be reversed or turned around so that the other side of the teeth will wear. This may be done by placing the left hand sprocket on the right hand side if in no other way.

In ordering roller chains or repairs three dimensions must be given in addition to the length or number of teeth wanted. The "pitch" of a chain is the distance from the center of one roller to the center of the next one to it.

The "diameter" is the outside diameter of the roller.

The "width" is the width of the roller, which is the same as the thickness of the sprocket it runs on.

CLUTCH.

D. Clutches are placed between the engine and the change speed gearing of the transmission so that the power of the running engine may be gradually applied to turn the wheels.

Four types of clutches are in common use. The cone clutch is a wheel with the rim at a slant and covered with leather or asbestos. This rim is fastened to the transmission and fits into the flywheel, which is turned out tapered to receive the clutch. The clutch is held into the flywheel by a spring or springs and may be withdrawn by a foot pedal and levers.

A multiple disc clutch is formed of a large number of metal discs, alternate discs being fastened to the engine flywheel and to the transmission shaft. Pressing these discs together with a spring causes the engine to drive the car and separating them with a foot pedal and levers releases the drive. These discs are made from steel, iron or bronze and may be faced with asbestos, leather or cork. The clutch runs in oil.

A dry-plate clutch is made like the multiple disc. It runs in the open air and does not usually have so many discs as the multiple disc type in oil.

A band clutch operates on the same principle as a brake, the drum being fastened to the engine and the outside band or inside shoes being fastened to the transmission. This type is very little used.

R. Clutches are usually more or less difficult to remove from the car. If the clutch is in the same case

MOTOR CAR PARTS

with the engine and transmission, called a unit power plant, it can only be removed by taking the universal joint apart back of the clutch. Then take out all the bolts that hold the transmission case to the engine case, remove the transmission and then take the clutch off the front end of the transmission. Unless the operating levers and pedals are all carried on the transmission case, all connections must be removed so that the transmission is free from all other parts.

If the clutch is in the same case with the transmission but separate from the engine it may be removed by uncovering the case and taking off the bearing caps

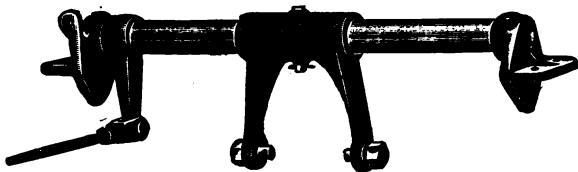

CROSS SHAFT AND ARMS FOR RELEASING CLUTCH.

at each end of the clutch and disassembling the universals or joints at each end. The clutch should then lift out of the case if all operating levers and parts have been detached.

If the clutch is fastened into the flywheel and separate from the transmission it will first be necessary to disconnect the universal joint between the clutch and transmission. Then remove all the clutch operating parts and parts that connect it to the car, engine or transmission.

If it is a cone clutch you will find one or more rather large nuts at the rear end directly in line with the end of the crank shaft. These nuts or bolts are locked in

place with special washers, locking nuts, pins, or by having a smaller bolt in the center of the large one. Removing or loosening these nuts or bolts will allow the clutch to be drawn off the end of the crank shaft.

In some cases the holding bolts will be found in the arms of the clutch wheel or spider, in which case there

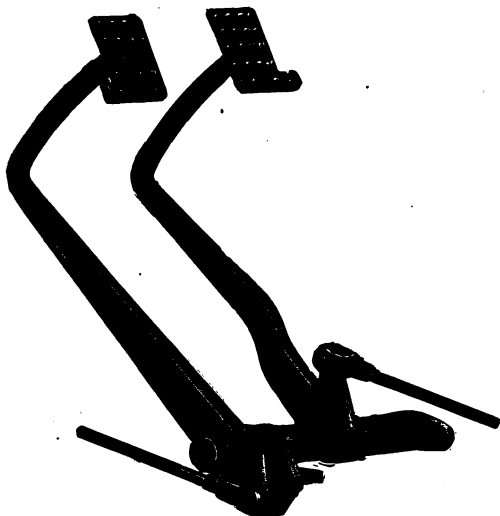

CLUTCH AND BRAKE PEDALS.

Showing method of fastening to the parts to be operated.

will be a bolt or nut and spring fastened to each arm. They must all be loosened or taken off.

Band, dry plate and disc clutches are usually held in place by a number of bolts or pins near or around the edge of the clutch inside the flywheel rim.

Enclosed multiple disc clutches are bolted to the flywheel by three or more bolts around the edge of the case.

Band. C. The center bearing on the crankshaft or extension should have two or three turns of a grease cup each day of use and the thrust release bearing should have grease every day. Heavy cup grease is best in these parts.

The surfaces of the drum and shoes of bands must be kept clean and dry at all times unless the clutch is enclosed and designed to run in a bath of oil.

A. The adjustment of a band clutch is made by means of a screw or nut inside the drum or in the band on the drum. Tightening or loosening this adjustment will tighten or loosen the clutch. Care should be used in this adjustment as a quarter turn will make a great difference in the clutch action. Turn the adjusting screw a very little and then try the clutch action with the engine running. Adjustment may also be made by tightening or loosening the clutch operating spring which may be in the clutch or outside and attached to some of the operating parts.

T. Band clutches will give trouble of various kinds. They may drag or spin (refuse to stop quickly when released by the pedal), grab (take hold too quick), or slip while the engine is pulling the car.

Some band clutches have the parts all metal. If the contact surfaces become rough they must be turned in the lathe until smooth and true.

If the shoes or bands have a separate facing it is renewed as described under Brakes.

If the clutch drags or spins the main bearing may be excessively worn so that it needs replacement or this bearing may only need oiling. Too tight an adjustment will also cause the clutch to spin.

If the clutch grabs, the contact surfaces may be dirty

and need to be cleaned but not oiled, or the adjustment may be too tight. The spring tension may be too great or play in the operating parts may allow the clutch to engage too quickly.

A slipping clutch probably has oil or grease on the surfaces, is not adjusted tight enough or has not enough

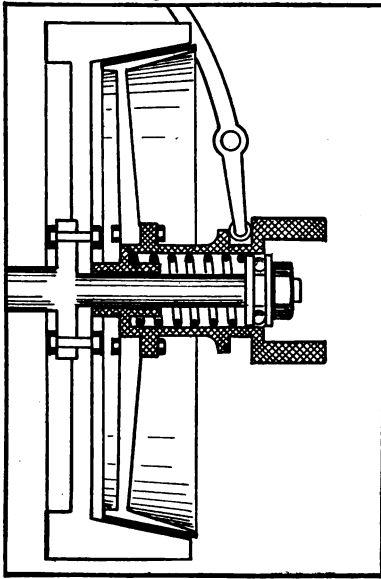

CONE CLUTCH.

Showing clutch spring with nut on end of shaft for changing its tension.

spring tension. Slipping is also caused by the bearings or moving parts being so worn that the surfaces do not make full contact.

Cone. C. There are two bearings in a cone clutch which require constant lubrication. One of them is the bearing on the end of the crank shaft or the extension

in the flywheel on which the center of the clutch turns. This bearing has a grease cup which must have two or three full turns every day of use. Failure to do this may cause the clutch to seize on the shaft so that it will not release. The other bearing is the one that is used to pull back on the clutch so that it will release from the flywheel. This must be greased every day the car is used.

The facing of a cone clutch must be kept clean and free from grease or oil on the surface.

A. Cone clutches are adjusted by tightening or loosening the spring or springs that hold the cone into the flywheel, by moving the bolt that is in the end of the crankshaft in the center of the clutch or by turning the bolts in the arms of the clutch. After adjusting the bolt or nut be sure that it is locked in position and never try to turn any of the adjustments until you have released the locks.

In order that a cone clutch may take hold easily and smoothly the surface of the leather or asbestos facing is often raised at certain points around the clutch by springs placed under the facing. These springs or plungers push the facing up in spots and these spots touch the flywheel first. This starts the car easily and as the clutch is allowed to press tight into the flywheel the easy engagement springs are flattened down so that the whole clutch surface holds. These springs are usually adjustable from the inside of the clutch rim so that the clutch may be made to take hold very gently.

T. The face of the clutch is covered with leather or asbestos brake band lining and as the clutch wears this lining or facing becomes worn smooth and thin and will finally need replacing.

To attach the asbestos, secure pieces about eight or ten inches long and as wide as the face of the clutch. These may be bent to shape and attached by riveting as directed under Brakes.

Leather facing requires more preparation than asbestos. First secure leather of the proper thickness, usually about $\frac{3}{8}$ to $\frac{1}{4}$ inch, in pieces from eight to sixteen inches long and about one to two inches wider than the width of the face of the clutch. The longer the strips the wider they must be.

Soak these pieces of leather in water until wet through and then apply them to the clutch face.

To apply the leather, take one of the pieces and lay it over the clutch face so that all parts of the metal face are covered with the leather. Lay one end of the new piece at the same place that one edge or end of the old piece was laid and mark the rivet holes on the leather with a punch stuck through the holes in the metal face.

Now countersink the holes as directed under Brakes and with the proper size of copper rivets rivet the new facing into place, drawing it tightly over the face so that the leather covers the metal smoothly. The smooth side of the leather should be out so it will touch the flywheel.

Attach each piece in this way until the whole face is covered, then allow the leather to dry perfectly and cut off the edges that extend over the metal.

Now soak the clutch over night in neatsfoot or castor oil, wipe off the excess oil on the surface and replace the clutch in the car.

If a cone clutch drags or spins it may be that the main bearing needs oiling or that this bearing is so

worn that the clutch drops down onto the flywheel rim. The clutch spring sometimes sticks in its housing and must be freed. The release thrust bearing may need oiling or the small shoe or piece that rubs on the clutch rim when released may be worn off. This small shoe is called a clutch brake and is designed to prevent the clutch from spinning when released. The facing on the clutch may have pieces sticking up and rubbing on the flywheel.

If this type of clutch grabs, the leather may be dried out and you should rub neatsfoot or castor oil onto the facing. There may be dirt between the faces or the easy engagement springs may not be doing their work properly. The main bearing may be so worn that one side of the clutch takes hold first and grabs, or the facing may be worn out and need renewing.

If the clutch slips while the engine is pulling the car, the facing may be too oily or have grease thrown on it. It should be washed with gasoline or powdered chalk or soapstone should be sprinkled on the leather. The clutch facing may be rough or worn out or it may be worn so that there is a ridge or shoulder that prevents it from going tight into the flywheel. There may not be enough spring tension or the operating and release parts may be binding so that the clutch can not go tight into the flywheel.

Dry Plate. C. The principal care required by a dry plate clutch is that the contact surfaces be kept clean and dry and smooth and that the main and release bearings be kept well greased every day.

Never oil the surfaces of a dry plate clutch. If they should become oily or greasy clean them with gasoline or kerosene and allow them to dry before using.

A. Dry plate clutches are adjusted by tightening or loosening three or more arms or cams or small springs found around the arms of the clutch or else by one large nut or bolt at the center. Be sure to loosen the locking devices before starting adjustment and lock them up when finished.

T. If part of the discs are faced with asbestos or leather and this facing is worn out new material may be riveted on as directed under Brakes. Use the same material and the same thickness as originally used.

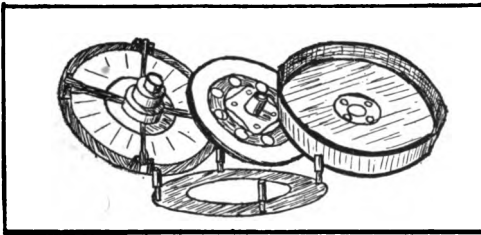

DRY PLATE CLUTCH PARTS.

If the discs are all metal and have deep ridges worn in them they should be replaced with new parts although the ridges may be dressed off by mounting the discs on the lathe face plate and grinding with an emery wheel on the slide rest.

If a dry plate clutch does not release properly but drags or keeps on spinning, the plates may not leave contact with each other because of binding or broken parts. The plate surfaces may be dirty or gummy or part of the facing may be loose and touching the adjoining plates. The main or release bearing may need oiling also.

MOTOR CAR PARTS

If this type of clutch grabs, there is too much spring tension or the surfaces are dirty or gummy.

If a plate clutch slips the faces may be oily or the plates may be worn out or there may not be enough spring tension.

Multiple Disc. C. Multiple disc clutches are lubri-

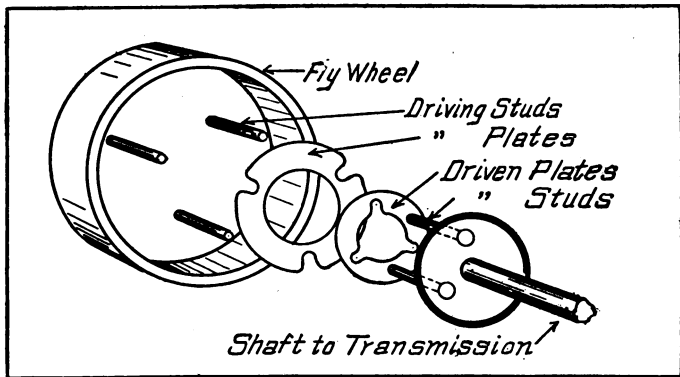

MULTIPLE DISC CLUTCH PARTS.

cated by filling the clutch case or housing not more than one-third full of medium weight cylinder oil. A heavier oil should be used in summer than in winter. Some clutches work best with a mixture of one-fourth to one-half kerosene with the oil.

The release bearing of a multiple disc clutch requires oiling or greasing every day if outside the clutch.

A. Multiple disc clutches are adjusted by increasing or decreasing the spring tension by the large nut at the back of the shaft or by three or more smaller springs around the edge of the clutch. Adjustment may also be secured by using thinner or thicker oil or more or less kerosene in the oil.

R. In assembling a disc clutch care should be used first to find which bolts, keys or pieces revolve with the engine and which ones are fastened to the transmission. Every alternate disc should be fastened to the engine parts and the other discs to the transmission.

T. If a multiple disc clutch leaks oil it is usually because the case is more than one-third full or it may be because the felt washer around the shaft at the back end of the clutch needs renewing or tightening up. Leakage may also come between the clutch case and the flywheel where the clutch is bolted to the wheel in which case a shellaced paper gasket should be placed at this point. The clutch may also leak because the small filling plug is not screwed in tight.

The discs may wear out from long use, lack of oil or too much slipping. They will then show deep grooves, extreme thinness, warping, bending or discoloration due to heat. The only right remedy is new plates.

Dragging or spinning is caused by too much spring tension, by the release parts being so worn that they do not give enough movement, or the release parts may not be adjusted to give sufficient release. Back of many disc clutches is a small disc of steel or steel faced with leather against which the revolving part of the clutch comes when it is released. This is intended to stop the transmission end of the clutch from turning so that the gears may be easily meshed and is called the clutch brake. If it is worn out or dirty or greasy it will allow spinning. The plates may be worn out or warped, the oil may be too thick or dirty or there may not be enough oil.

If the clutch grabs there may be too little oil in the case, the oil may be old or dirty or too thin. The plates

may be worn or warped, there may be too much spring tension or the releasing parts may bind in some positions.

A slipping clutch may be caused by the oil being too thick, in which case some kerosene should be added. The plates may be worn out, there may not be enough spring tension or the release parts may not be set to allow full engagement or they may bind.

COMPRESSION.

After the cylinder of the engine has been filled with gas on the inlet stroke, this gas is compressed on the following up stroke of the piston with both valves closed. It is absolutely essential that but very little, if any, of the gas escape from the cylinder during this compression stroke. There are many chances for leakage and this lost gas causes the engine to lose power and to use more gasoline. It also causes missing, hard starting and many other troubles.

To test the compression of a cylinder—remove the spark plugs or open the pet cocks in all the cylinders except the one to be tested. Now turn the crank shaft with the hand crank until a resistance to turning is felt because of the gas being compressed in that cylinder. If no resistance is felt all the gas is leaking out.

To locate the compression stroke turn the crank until the exhaust valve opens and just closes. Turn the crank one-half revolution from this point of exhaust valve closing and you are then at the beginning of the compression stroke. During the next half turn of the crank the resistance of compression should be felt.

If the compression is good in the cylinder being tested it will be possible to pull the crank part way up on the compression stroke and then release the pull on the crank. The compressed gas in the cylinder should cause the crank to move backward almost to the place where you started to pull out. This may be re-

peated a number of times if the compression does not leak. The compression should also be good enough to make it quite hard to turn the crank around slowly. Each cylinder should be tested in this way.

Leaks of compression may come from around the

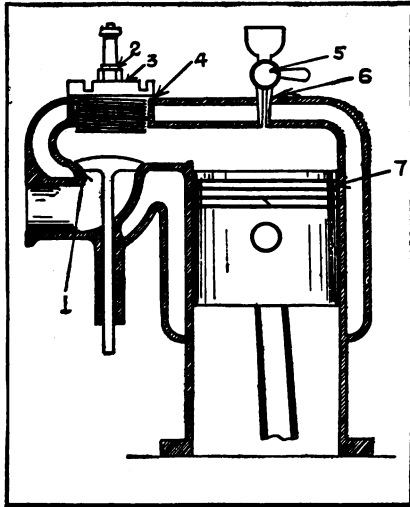

POINTS AT WHICH COMPRESSION MAY BE LOST.

1, Leaky valve; 2, Leak around spark plug insulation; 3, Leak around spark plug threads or gasket; 4, Leak around valve cap; 5, Leak in priming cup shut off; 6, Leak around priming cup threads; 7, Poorly fitting piston rings.

threads of the spark plugs, priming cups, valve caps or from the joint of a separate cylinder head. Compression may be lost past leaky valve seats or past piston rings that do not fit properly. Very rarely compression is lost through cracks in the cylinder or piston head.

Leaks around the threads or joints are detected by squirting oil around them and then turning the crank to test the compression. Bubbles will show the leaks. Every joint and gasket should be tried in this way. Leaky valves have their face and seat rough or pitted and must be ground. The leak past the valve may be from dirt or carbon between the face and seat. Leaky rings can be detected by looking for blackened or browned spots around the ring. They cause a hot crank case.

See under Power, Loss of.

CONNECTING ROD.

D. The connecting rod connects the piston to the crank shaft and is usually made of an H-section drop forging or a tubing.

T. The connecting rod may be so slightly bent that it is not noticeable to the eye and yet this will cause trouble in the connecting rod bearings loosening up continually.

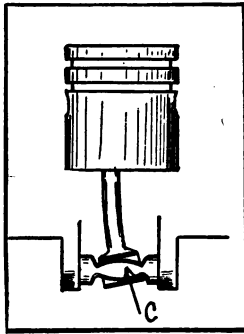

EFFECT (EXAGGERATED) ON THE CRANK PIN BEARING OF A BENT CONNECTING ROD.

To test the straightness of a connecting rod, remove the cylinder but leave the piston and connecting rod in place. Lay one leg of a steel square on the top of the part of the crank case to which the cylinders attach or to any level and horizontal part of the crank case. Hold the other leg of the square straight up by placing a

smaller square against the side of the first one and bring the upright edge of the first square against the side of the piston at the point where the wrist pin hole comes through. If the piston does not test square to the case it must be made so by scraping the bearing or by bending the connecting rod.

Forged rods may be bent slightly while cold.

COOLING SYSTEM.

D. The cooling system of a car using water includes the water jackets around the cylinders, the piping, the radiator and the pump if a pump is used, and a fan.

C. In order that the cooling system may work prop-

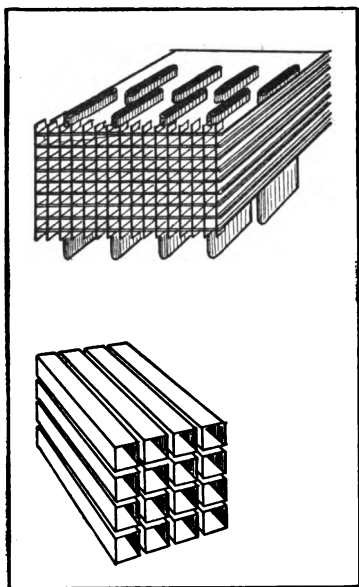

UPPER ILLUSTRATION—TUBULAR RADIATOR; LOWER ILLUSTRATION—CELLULAR RADIATOR.

erly the cylinder jackets, piping and radiator must be kept clean inside and the radiator must be kept clean outside.

The piping must not become bent or filled with

sediment or clogged in any way, the radiator must not leak, the pump must revolve so as to force the circulation of the water and the fan bearings must be kept adjusted and lubricated and the fan belt and pulleys must be clean and tight.

R. In replacing a pump make sure that all keys and pins and shafts are in working order and not sheared or broken. Also examine the pump to see that it rotates in the direction that will cause it to draw the water from the bottom of the radiator and send it to the engine, not the other way around.

T. To clean the inside of the cooling parts of the car first fill the system with water, then draw it off and see how many quarts the system holds.

Make a mixture of caustic soda with water so that each eight quarts of the mixture will contain five pounds of soda, and make enough mixture to fill the system. Caustic soda may be secured from any laundry or laundry supply house. It is a strong lye and will cause bad burns on the flesh.

Fill the cooling system with this mixture and run the engine ten to twenty minutes. Then stop the engine and drain the mixture out. Wash the system out with running water or by filling with clean water several times.

To prevent the water in the cooling system from freezing in cold weather many mixtures are used, the commonest being alcohol with the water. Mixtures are also made from glycerine and water; or half water, one-fourth glycerine and one-fourth alcohol. Wood or denatured alcohol is usually used.

One-fifth of wood or denatured alcohol will stand 10° above zero, one-fourth alcohol stands 5° above zero and one-third alcohol stands 5° below zero.

Wood alcohol lowers the freezing point slightly more but evaporates from the mixture faster than denatured alcohol. Glycerine damages the rubber in the piping slightly. Equal parts of glycerine and alcohol will not steam away as quickly if the weather warms up and gives the same effect in anti-freezing. Any form of salt attacks the metal and any form of oil damages the rubber, causes danger from fire and is dirty and hard to circulate.

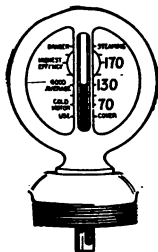

INDICATOR FOR TEMPERATURE OF WATER.

The height of the liquid in the thermometer shows how warm the water is. The lowest point shows water ready to freeze, 70° is too cold for efficiency, 130° is the lowest heat for proper operation, 170° is just right and above that point the water may boil away.

Troubles in the Cooling System.

1. Fan belt loose so that fan does not run fast enough. Tighten.
2. Fan bearing sticking. Take apart, clean and oil.
3. Water level too low. Look for leaking connections.
4. Leaks around pump bearings. Put in new packing (wicking).
5. Sediment or obstructions in the piping or radiator. Clean.

6. Hose rotted or loose inside. New hose.
7. Hose kinked. Straighten out or shorten.
8. Packing or gaskets swollen so that opening is closed. Cut the hole out larger.
9. Air locks in piping. Comes from having pipes turn up and then down again. Straighten them out.
10. Dirt, oil or scale on the radiator. Clean with gasoline or brush.

MOTOR CAR PARTS

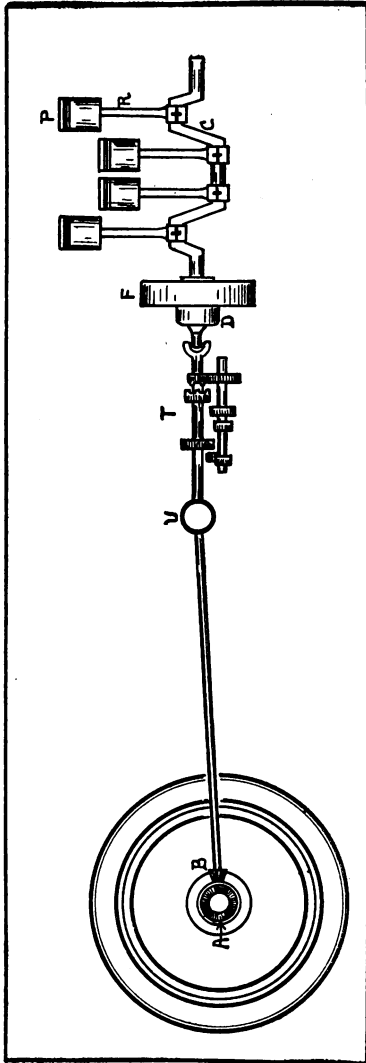

PARTS THAT CARRY THE POWER.
P, Piston; R, Connecting rod; C, Crank shaft; F, Fly wheel; D, Clutch;
T, Change speed gearing; U, Universal joint; B, Drive shaft and bevel
pinion; A, Differential and axle.

CRANK SHAFT.

R. Crank shafts are carried by either annular ball, roller or plain bearings, usually the latter. The crank shaft may be fastened into the upper half of the crank case (when this half is mounted in the frame) or it may be carried in the lower half of the crank case (when the lower half is mounted in the frame).

In the latter case the cylinders and upper half of the case must be removed before getting at the crank shaft.

Other engines have the crank case in one piece, called a barrel type, when the crank shaft and its bearings are slipped into one end or the other. The bearings then are held in large rings that fit into circular holders inside the case. These rings must be loosened before sliding the crank shaft out.

T. Should the crank shaft become ever so slightly bent out of line it will cause the bearings to become loose continually no matter how often tightened. If it is much out of line it will also cause a heavy, dull pounding noise.

The only way to test the trueness of a crank shaft is to remove it and place it between the lathe centers, turning it and testing each bearing to see if it runs true.

A bent crank shaft may possibly be straightened under the arbor press while cold if the bend is very slight but this is a risky performance. The best way is to send it to a large shop or to an experienced man having the facilities for this work.

CYLINDER.

R. In removing cylinder castings from the crank case be sure of two things:

1. That you have removed all wires, pipes, levers, manifolds, rods, and everything else that must come loose before the cylinders can come off.

2. You must prepare to pull the cylinder castings straight up and so that you can avoid twisting them sidewise, backward or forward. This will prevent damage to the pistons or connecting rod bearings.

The openings in the piston rings must be as far apart as possible so that the gas will have to travel a long distance sidewise before getting past the rings. If there are four rings, the opening in the second one should be one-fourth of the distance around the piston from the opening in the first one, the third should be another quarter of the way around and so on for all the rings.

Before replacing the cylinders the outside of the piston and the inside of the cylinder walls must be well oiled with cylinder oil.

Have one piston up and the other down as far as they will go and let one man lower the cylinders onto the pistons while another holds the pistons straight up and in the proper position. The cylinders must be lowered into place while being held straight, not twisted to one side or the other.

The man who holds the pistons must press the rings

tight into their slots so that the cylinders will slip over the rings. This can be done with the thumbs. In some cases it will be necessary to squeeze the ring together with a metal band or wire.

The nuts that hold the cylinder to the crank case should all be placed on their bolts or studs before any of them are made tight. Turn all the nuts down until they begin to draw tight and then keep going from one nut to the next until all are tightened evenly. Do not draw one nut tight and then go to the next.

T. A cylinder casting may become cracked from accident or from allowing the cooling water to freeze. A cracked cylinder may be repaired by oxy-acetylene welding, brazing, cementing, rusting, caulking or patching.

Running an engine with too little or no oil or without water causes the pistons to cut scratches or score marks on the inside of the cylinder walls.

If the marks are deep, the remedy is a new cylinder, piston and rings; or the old cylinder may be bored larger and a larger piston and rings fitted. If a new piston is not fitted the looseness may cause a threshing noise called piston slap.

If the scratches are slight they may be eradicated by lapping. First remove all traces of oil and carbon from inside the cylinder and cover the inside of the walls with a paste of fine emery powder and cylinder oil. Now secure or cut out a piece of iron or steel about four inches long and that just slides into the cylinder. Fasten a bolt into one end of this piece for a handle. The rings may be removed from the piston and the piston and connecting rod used in place of the special piece if it is impossible to get the piece.

Cover the piece of iron or steel or the outside of the piston with a coat of the emery and oil and slide the piece or piston into the cylinder. Work it back and forth and turn it slightly all the time. Continue this for some time and then remove the piston or lap, wash the inside of the cylinder and see if the marks are gone. Repeat this process until the cylinder is smooth. Using the piston wears it away faster than it wears the cylinder and causes looseness, therefore a special piece should be made if at all possible.

When the marks are gone fit new rings to the piston and after washing every trace of emery from all the parts replace them.

This process is also used for fitting pistons that are too tight.

DIFFERENTIAL.

D. The differential gearing is for the purpose of allowing one driving wheel to turn faster or slower than the other while turning a corner. Both wheels receive power from the engine.

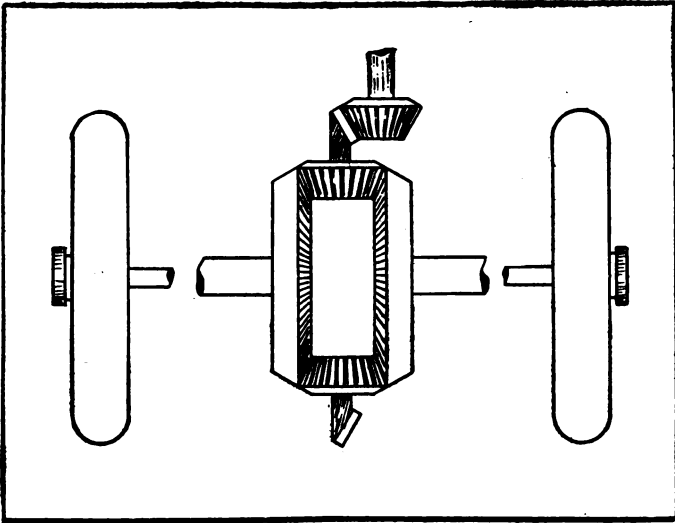

PRINCIPLE OF THE DIFFERENTIAL.

A. The only adjustment the differential gearing could need would be from wear. The worn bushings, bearings or gears would have to be replaced with new ones.

Wear in a differential may sometimes be overcome by taking it all apart and reassembling, with the gears, bearings, pins, etc., in a different position relative to each other.

R. Before taking a differential apart every gear, pin, bushing, bearings, bolt and nut should be carefully marked or numbered, showing exactly how they go back together in relation to each and all of the other parts. Otherwise the differential will be stiff or may not turn at all. Mark right and left, up and down, top and bottom, front and back.

When you place the differential with the large bevel gear in the rear axle or jack shaft be sure that the bevel gear is on the side of the small bevel pinion that will cause the wheels to turn forward in the forward speeds and backward in reverse. Placing the bevel gear on the wrong side will cause the car to have several reverse speeds and one forward.

EIGHT-CYLINDER ENGINES.

Eight-cylinder engines differ from four and six-cylinder types in but four particulars. The differences consist of the increased number of cylinders; the arrangement of the cylinders in two sets of four, set at an angle to each other; the changed firing order and the construction of the lower end of the connecting rods.

The increased number of cylinders gives a more even and continuous turning effort on the crankshaft and presents no greater difficulties to the user or repairman than the better known types.

The cylinders are divided into two sets of four cylinders each, these sets being set at right angles or square to each other. This brings one set on the right-hand side and the other set on the left-hand side of the car. The cylinders have both inlet and exhaust valves on the same side, forming what is known as the "L" head type. The valves on each set of cylinders are placed on the inside or toward the other set of cylinders. This arrangement allows the use of one crankshaft for all cylinders and requires but one camshaft. The camshaft is carried on a removable plate directly over the crankshaft between the two sets of cylinders. The cylinders of one set are placed directly opposite the other set so that the whole engine and the crankshaft are no longer than a four-cylinder engine and shaft of the same cylinder size.

An eight-cylinder engine may have any one of eight firing orders, the one used in any particular engine

being found in the same way that the firing order of any other engine is found, that is, by watching the order of opening of either the inlet or exhaust valves. The cylinders of one set of four may fire in the order 1-3-4-2 or 1-2-4-3, the cylinders of the other set may fire in exactly the same order as the set first considered or they may fire in the other order of the two given. The cylinder of the second set that fires next after the first cylinder in the first set, determines the firing order of that engine.

Indicating the cylinders of the right-hand set by the letter R and the cylinders of the left-hand set by the letter L, the possible firing orders are as follows:

1R-1L-3R-3L-4R-4L-2R-2L.

1R-1L-3R-2L-4R-4L-2R-3L.

1R-4L-3R-2L-4R-1L-2R-3L.

1R-4L-3R-3L-4R-1L-2R-2L.

1R-1L-2R-2L-4R-4L-3R-3L.

1R-1L-2R-3L-4R-4L-3R-2L.

1R-4L-2R-2L-4R-1L-3R-3L.

1R-4L-2R-3L-4R-1L-3R-2L.

The magneto distributor will have eight terminals which must lead to the cylinder ready to fire at the time required just the same as in any other engine.

There are four possible constructions of the lower ends of the connecting rods, these being shown in the accompanying illustration.

(1) The two connecting rods of opposite cylinders may be placed side by side on the same crank pin, requiring that the cylinders be slightly offset.

(2) One of the connecting rods may be made of large size and with a pair of projecting lugs on one side, these

lugs carrying a pin. The lower end of the other connecting rod has its bearing on this pin.

(3) The lower end of one connecting rod may be made in the ordinary way and placed in the center of the crank pin. The other connecting rod end is split or forked, one leg of the fork being placed each side of the first rod end. This gives two bearings in the second rod end, each bearing being about half the size of the one bearing of the first rod. This method is open to the objection that the three bearings on one crank pin tend to form ridges or grooves around the pin.

(4) The rod ends are shaped in the same way as described above, that is, one of the ends is enclosed by the yoke of the other. The rod having the usual shaped end clamps tight around the bearing liner or bushing so that the liner must always turn with this rod. The liner extends outside the ends of this rod and on these outside extensions are mounted the two forked ends of the other rod so that the second rod has its bearing on the outside of the bushing clamped by the first rod, the first rod having its bearing directly on the crank pin in the usual way.

EXHAUST MANIFOLD DESIGN.

T. A very peculiar trouble sometimes can be traced to the exhaust manifold of a six-cylinder car. The length of each exhaust valve opening is about 225° . It will be seen that the six cylinders will be exhausting during a total of six times 225° or 1350° . In the two complete revolutions of the crank shaft necessary to complete the cycle and bring the first valve back to its exhaust opening there are but 720° , so it will be seen that more than one exhaust valve must be open at one time.

As a cylinder is finishing its exhaust the gas comes out of its valve at rather low pressure. Another cylinder near it will start to exhaust with the gas coming from its valve at high pressure. This raises the pressure in the exhaust manifold to a point where burned gas will be forced back into the first cylinder.

This can be remedied only by a very large manifold, exhaust pipe and muffler; or, as is done in some cars, there may be two exhaust manifolds, one for each set of three cylinders.

This condition with a small manifold will cause a considerable loss of power. This loss is lessened by having the firing order so that adjoining cylinders do not fire one after the other. Such firing orders would be 1-4-2-6-3-5, 1-5-3-6-2-4, 1-3-2-6-4-5, etc.

FIRING ORDERS.

The firing order of an engine means the order or sequence in which the different cylinders fire their charge, always starting by mentioning number one next the radiator.

A single cylinder engine has therefore no firing order, a two-cylinder always fires 1-2, as there are no other cylinders to come between; a three-cylinder might fire 1-2-3 or 1-3-2.

A four-cylinder engine will always fire 1-3-4-2 or else 1-2-4-3.

A six-cylinder engine may have almost any firing order except 1-2-3-4-5-6.

The reason for not having the cylinders fire one after the other according to the number of the cylinder is that this distributes the strain on the crank shaft more evenly and makes for better engine balance. Whenever a cylinder fires the connecting rod springs the crank shaft slightly. This springing would be carried from end to end of the shaft if the cylinders fired one after the other from front to back and would then be suddenly transferred to the other end of the crank shaft.

By having the cylinders firing next after each other separated by one or more other cylinders this strain is gradually moved along the shaft. The six-cylinder orders meeting this condition best are those in which number one fires; then some cylinder in the last group

of three, number 4, 5 or 6; this one being followed by number 2 or 3; then back to the last group, etc.

It is necessary to know the firing order of an engine in order to run wires from the magneto distributor to the spark plugs so that the cylinders will receive the spark in the same order in which they fire.

To find the firing order of an engine, watch either the inlet valves or the exhaust valves, but not both. Turn the engine slowly until the valve on number one cylinder opens. Now watch, or have a helper watch, for the next valve to open and after that the next one, etc. The valves open in the same order in which the cylinders fire.

FLYWHEEL.

D. The flywheel is for the purpose of making the engine run evenly from one explosion to the next, for that reason the fewer the number of cylinders and the greater the time between explosions the larger the wheel required.

Flywheels are fastened to the front or rear end of the crank shaft by being bolted to a ring or flange which is in one piece with the crank shaft. There may be from four to eight bolts. Older forms of construction have the wheel fastened to the end of the shaft with one or more keys and nuts, the end of the shaft being either straight or tapered.

When flywheels are mounted, small holes are bored at points in the rim that make the wheel, crank shaft, pistons and connecting rods just balance each other.

R. In replacing the flywheel it must be placed in exactly the same position as found, and to insure this, it is best to mark with a center punch the proper position on the wheel and shaft or flange. Failure to do this causes the engine to vibrate.

Keys must be a true, tight and perfect fit along their entire length and the hole through the flywheel must just fit over the shaft without looseness or play. Otherwise a bushing must be inserted.

When bolting a flywheel onto a flanged shaft see that the depression in the flywheel fits over the flange exactly and that there is nothing between the shaft and wheel or flange and wheel.

Each bolt must fit its hole exactly without looseness and the bolts and nuts must be drawn very tight and securely locked with cotter pins and castellated nuts or other suitable means other than lock washers. A loose flywheel makes a heavy pounding noise whenever the engine runs and must be tightened immediately.

FRAME.

D. Automobile frames are usually made from thin plates of steel pressed into a channel section and formed to make the shape desired under heavy presses while the metal is cold. They are called cold pressed channel steel frames.

Some frames are of wood or of wood enclosed by metal.

Truck frames are made from channel, "I" beam or angle steel.

T. A bent frame may be straightened cold if the bend is long and gradual but if the bend is sharp the frame will crack., To straighten a frame cold it is necessary to use jacks, bars and chains to force it back into shape. To straighten sharp bends the frame must be heated by means of a brazing torch or an oxy-acetylene torch when the frame is allowed to remain in the car, or in a forge fire if the frame is taken out of the car.

When the part of the frame where the bend is has reached a red heat it may be easily bent and hammered or pulled back into shape, with the help of large bars, wrenches and heavy hammers.

Allow the frame to cool slowly and then heat it again until it just reaches the heat where it will no longer attract a magnet, then let it cool slowly from this point while covered with asbestos sheeting. This last heating is to restore the strength of the steel.

MOTOR CAR PARTS

A cracked frame may be welded while in the car by means of the oxy-acetylene welding torch.

If the frame cannot be welded, repair it by making a patch of steel of the same or greater thickness than the frame itself and shaping this patch so that it just fits inside the frame where it is cracked. Make the patch touch the vertical and horizontal flanges of the

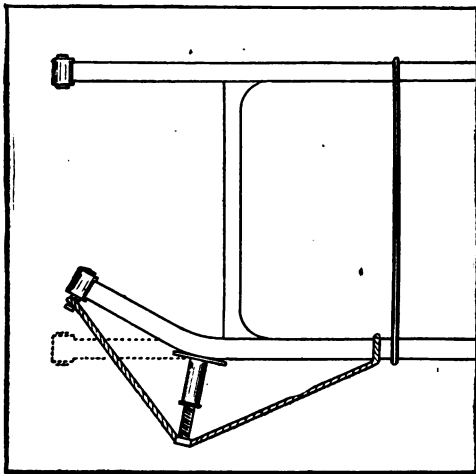

STRAIGHTENING A BENT FRAME WITH A JACK AND STEEL CHAIN OR CABLE.

frame evenly at all points and have it extend at least six inches each way from the crack. This piece is then riveted in place with five-sixteenth inch rivets placed two inches apart and driven in hot with heavy blows of the hammer.

A frame broken in two may be patched as given above except that the patch should extend a foot each side of the crack and in addition to this a truss should

be fitted to support the frame where broken. This truss is made from a seven-sixteenth inch diameter cold rolled steel rod about six or seven feet long. A ring must be fitted to each end of this rod or it may have the end bent into a ring. This ring is to be bolted to the frame on the lower side about three feet from the broken place. The other end of the rod will be bolted to the frame about the same distance the other side of the break so that the rod runs along under the frame past the broken place. A solid piece of steel at least two inches thick must be made and placed between the frame and the rod so that the piece comes directly under the broken place and supports it. A turnbuckle may be placed in the rod so that it may be drawn tight, giving the broken place a firm support.

FUEL FEED.

Gravity. The simplest method in use for causing a flow of fuel from the tank to the carburetor is that known as the gravity system, in which the tank is at a point sufficiently higher than the float chamber of the carburetor to cause a natural flow. This allows three locations for the tank: under the driver's seat, on the dash or in the cowl of the hood and directly over the engine.

The demand for cars hung low to the ground has made it necessary to lower the seats to a point at which it is difficult to find sufficient room under the seat for a tank of the proper size and capacity. Unless the tank can be placed at a proper height the flow to the carburetor may be stopped on a steep hill when the bottom of the tank may be below the level of the carburetor float chamber.

Care must be used to see that air can find its way into the tank to take the place of the gasoline that flows out. To allow this, there is a small hole at some point, usually in the filler cap, which must be kept open.

Care must also be used to see that all joints in the piping are tight and that the carburetor does not "flood," as any form of leakage will cause the entire contents of the tank to flow out, wasting the fuel and making a source of danger from fire.

Pressure. The desire for positive fuel feed regardless of the quantity of fuel in the tank or the location

of the tank has led to the adoption of the pressure feed. This allows the tank to be located at any convenient point on the car, either under the seat or at the rear of the frame. The rear location allows greater accessibility for filling, although the tank is exposed to more damage from accident.

Pressure is supplied by a plunger pump or from the exhaust gases. The plunger pumps usually operate from the crank or valve operating shaft, being fitted with ball or poppet types of check valves. Pressure is taken from the exhaust gases by causing the gas to operate a plunger or a flat disc of metal called a diaphragm. This metal is placed in a housing in such a way that the exhaust pressure reaches one side and causes the metal to have a slight buckling movement (like the bottom of some pans when pressed up and down). This movement of the diaphragm acts as a pump plunger, forcing air into the tank or drawing fuel from the tank.

Plunger pumps of all types require that their valves be kept perfectly tight and free from dirt or soot from the air or exhaust gases. All piping from the pump to the tank must be kept tight or no pressure will be delivered into the tank.

As the pressure of air is raised in the tank the fuel is caused to flow out of another pipe leading to the carburetor. To start the car after the tank has been opened or at any time when no pressure remains in the tank recourse is had to a hand pump. A pressure of one to three pounds of air to the square inch is ample in all cases.

Vacuum. A comparatively new method of causing the fuel to flow from a tank below the level of the

carburetor is that known as the vacuum system in which advantage is taken of the suction in the inlet piping caused by the downward movement of the pistons drawing air through the carburetor.

The parts required comprise a tank, usually mounted on the engine side of the dash. This tank is divided into two chambers, upper and lower. The upper chamber is connected to the intake manifold, while another pipe connects it with the main fuel tank. The lower chamber is connected with the carburetor. The intake strokes create a vacuum in the upper chamber, and this vacuum draws fuel from the tank.

As the fuel flows into this upper chamber it raises a float valve. When this float valve reaches a certain height it shuts off the vacuum valve and opens a valve leading to the outside air, allowing the gasoline to flow down into the lower chamber. As the fuel flows out of the upper chamber the float valve drops, opening the vacuum valve and causing the upper chamber to refill.

The lower chamber always has an opening leading to the outside air, so that fuel can flow to the carburetor as required.

Care must be used to see that the pipe leading from the inlet piping to the vacuum tank is tight and that all joints in the upper chamber are tight at all times. There must be no leaks in the pipe leading from the upper chamber to the fuel tank, but the fuel tank must have a small opening through the cap, or at some point that allows air to enter the tank to take the place of the gasoline drawn out.

This system of feed is also made to handle the lubricating oil in the same manner as the fuel is handled.

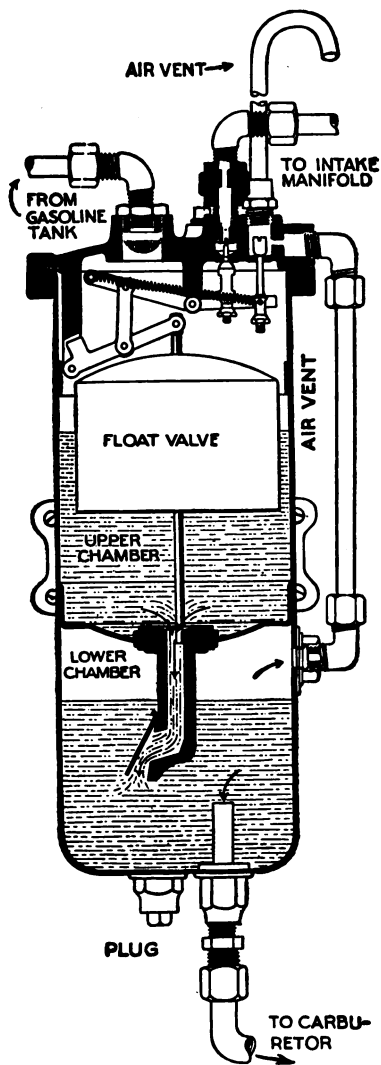

VACUUM FUEL FEED SYSTEM.
(Stewart-Warner.)

GEARS, TIMING.

D. Timing gears are those gears placed in the engine connecting the crank shaft with the cam shaft or the shaft that moves the parts opening and closing the valves, running the magneto, pump or other part. The shaft operating the valves always moves at just half the speed of the crank shaft in a four cycle engine and at the same speed in a two cycle. Therefore, in a four cycle engine the gear or sprocket on the crank shaft will be exactly half the size of the one on the cam or valve operating shaft.

Timing gears are for the purpose of regulating and controlling the time during the piston strokes at which the fresh or burned gases are admitted to or expelled from the cylinder.

R. The correct replacement of the timing gears on the engine is fully covered under Valve Timing.

T. Noise from the timing gears may be caused by worn or broken teeth in the gears, gears loose on their shafts, from the gears touching the covers or housings or bolts, or the gears may be crooked on the shafts.

Worn or broken teeth require that the gear be replaced by a new one. The new gear meshing with the old ones will make a humming or ringing noise, but this cannot be helped. Use will correct it as the gears wear to a fit.

If the gears are found to be loose on the crank, cam, valve or magneto shaft they should be removed and the hole in the gear should be made to fit over the end

of the shaft perfectly. This may require reboring of the gear or that the gear be bored out and a bushing inserted, this bushing then being bored the correct size and shape. The end of the shaft may have to be refinished on the lathe.

The keyway in the gear or shaft may be worn larger than the key in which case the keyways must be filed or chiseled to a regular shape and new keys fitted that exactly fit the keyways.

The nut or the pin that holds the gear onto the shaft may not be tightly in place or the threads or holes may be worn. This makes it necessary to re-thread the shaft or else use washers under the nut so that the remaining threads can be used. Pin holes will have to be reamed to a larger size and new pins inserted.

Should the gear rub against a part of the case or cover or a bolt or nut, it is probably caused by the gear being loose or out of line. A gear that is bent in itself must be replaced with a new one. After correcting these conditions if the noise still continues, file or grind the projecting parts away.

If the gears run out of line after being tightened as directed the shaft may be bent or the gear may be crooked on the shaft because of dirt in a tapered hole. This condition may also be caused by a key poorly fitted or too large, by a nut that has been cross threaded or started on crooked or by carelessness in placing the gear on the shaft.

INLET MANIFOLD.

C. The piping from the carburetor to the cylinders must be kept perfectly air tight at all points and at all times. To prevent vibration causing breaks and leaky joints the carburetor, and if possible the piping itself, should be steadied and supported by braces and clamps running to the engine (but not to the frame).

R. In replacing an inlet manifold the greatest care must be used to make every joint perfectly tight by applying well fitted, new and perfect gaskets at all points, these gaskets being coated with shellac if possible. Before the manifold is fastened on, every joint and thread should be tested for leakage by covering all openings except one with rubber stretched over a piece of wood and clamped or tied over the openings, then placing the pipe, or most of it, under water and blowing into the free opening while watching for bubbles. Every section of the piping must be tested in this way as a precaution.

T. One of the commonest of all car troubles is due to air leaking into the mixture, after it leaves the carburetor mixing chamber, through holes or cracks in the inlet manifold.

These leaks may come from defective gaskets at any joint or from holes in the manifold.

A leaky inlet manifold makes it practically impossible to adjust the carburetor for different speeds.

The easiest way to detect leaks when the manifold and carburetor are in place is to take a small squirt

can filled with gasoline and while the engine runs squirt the gasoline around all joints and all along the whole manifold. This should not affect the running of the engine, but, if there are any leaks the gasoline will be sucked into the piping and will usually make the engine run faster or slower or the engine may stop. The sucking of the gasoline may also be heard. The leaks must be exactly located and soldered or re-gasketed.

Some of the older cars have manifolds so long that the gasoline now used condenses along the walls of the pipe and thus spoils the mixture. The only remedy is a shorter pipe.

LUBRICATION.

D. Every moving part of a car must be lubricated by some means. The engine is supplied with cylinder oil which is forced by systems of pumping or splash or gravity flow to the bearings and sliding parts. The fan and pump bearings are supplied with grease cups or oil holes. The magneto bearings are packed in vaseline. The shafts on the engine all have grease cups when outside the crank case.

The clutch has its bearings fitted with grease cups or else it operates in a closed case and in an oil bath. The universals are packed in grease and have grease cups, the change speed or transmission gears operate in a case having light transmission grease or cylinder oil, the rear axle has transmission grease or cylinder oil in its housing, the wheel bearings are packed with grease and so is the steering gear. The axle pins and the spark and throttle and brake control parts are all fitted with grease cups or oil holes.

Oils and greases and lubricants are treated elsewhere.

A. The only types of engine lubrication requiring adjustment are those in which there are several pumps or one pump contained in a case or oiler carried outside the engine crank case and driven by power from the engine. On the outside of the case there is usually some part that rises and falls with the pump plunger and on or near this part is a nut or small screw that may be turned one way or the other to give the pump

a greater or less stroke, delivering more or less oil into the pipes. On top of these oilers are usually small pipes which have a screw needle valve in them. Opening this needle by turning the screw allows the oil to come from the pipe and shows how much oil is being pumped into that pipe.

Pipes leading to the crank case should give about two drops about every five seconds with the engine running at a moderate speed. Pipes leading to the cylinders should give about the same, or possibly three drops. Pipes leading to bearings should have one drop every ten seconds. Should this adjustment cause the engine to smoke, reduce the oil feed to the cylinders or crank case. As long as the engine does not smoke at the exhaust it is safe to increase the oil feed.

When the whole engine is oiled from one feed the delivery of oil should be started at four or five drops every five seconds and increased until the engine smokes and then gradually cut down until the smoking is stopped.

Other forms of oilers in use have arrangements so that the engine parts can use what they need, the balance being returned to the tank. The only care needed by these types is that the oil be kept in the tank or reservoir.

Oilers, oil tanks and oil reservoirs, whether on the crank case, in the engine or separate from the engine, always have some means of showing how much oil they contain. There may be small pet cocks fitted at different heights on the tanks, there may be a glass tube which carries the same height of oil as is in the tank or there may be a tube carrying a plunger with

an extension or marker at the top in sight of the driver or which can be seen by raising the hood. Other types have the oil flowing through a glass bowl or tube on the dashboard or on the crank case; if no oil is flowing the tank must be replenished immediately.

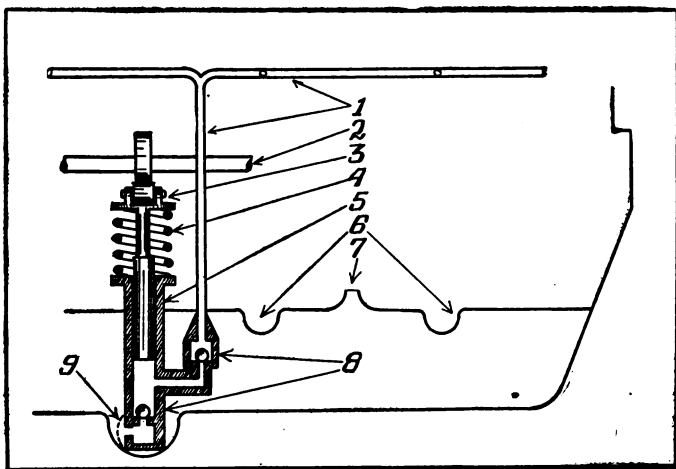

CIRCULATING OILING SYSTEM IN ENGINE CRANK CASE.

1, Oil pipe with holes opposite each connecting rod; 2, Cam shaft carrying extra cam which operates the pump plunger; 3, Roller on top of pump plunger; 4, Spring for returning plunger against cam; 5, Pump plunger case or barrel; 6, Depressions below the connecting rods in the crank case; 7, Overflow which prevents too high an oil level in the crank case; 8, Ball check valves preventing the return of oil the wrong direction; 9, Screen which filters the oil entering the pump.

Oil tanks having indicators of any kind should not be filled to the top as this will, in most cases, give the engine too much oil.

Parts of the car requiring lubrication daily are as follows:

Engine crank case or separate oiler, cylinder oil.

Clutch main bearing and release bearing, cup grease.

Parts requiring attention weekly are as follows:

Starting crank bearing or all cups and oilers on the lighting and starting dynamo and motor, cup grease.

Oilers, cylinder oil.

Fan bearing, grease or oil.

Magneto shaft, cup grease.

All spring bolts and shackles, cup grease.

Water pump shaft, cup grease.

Timing gear grease cups, cup full of cup grease.

Overhead valve operating parts, cylinder oil.

Steering gear case, cup grease, full cup.

Gear shifting parts, cup grease.

Clutch release shafts, etc., cup grease or cylinder oil.

Parts requiring attention twice a month are as follows:

Steering knuckle bolts, cup grease.

Steering cross rod ends, cup grease.

All brake operating parts, cams, pins and shafts, cup grease or cylinder oil.

Parts requiring attention every 1,000 to 1,500 miles:

Magneto oil cups, light machine oil.

Multiple disc clutch housing, cylinder oil.

Wheel and steering pivot bearings, light transmission grease.

Steering fore and aft rod or drag link ends, cup grease.

Transmission case, light transmission grease or cylinder oil.

Rear axle and differential housing, light transmission grease or cylinder oil.

Dynamo and starter gearing or chains, cup or transmission grease.

Parts to be lubricated every 2,000 to 3,000 miles:

Spring leaves, cylinder oil and graphite.

Universal joints, cup grease and graphite.

Dynamo and starting motor bearings, vaseline.

T. With Any Type—

1. Oil level too low. Causes heating. Add oil immediately.

2. Piping clogged, leaking, bent or has loose joint. Remove pipe and blow toward end from which the obstruction entered the pipe. Straighten, pack or tighten joint.

With Circulating Systems—

1. Oil dirty, old or worn out. Replace with fresh and wash out reservoir every 1,000 miles running.

2. Filter screens dirty. Clean with gasoline and brush.

3. Pump has broken drive or is worn out. Replace drive or entire pump.

4. Pump valves not seating. Remove and clean seat and grind with powdered glass and oil if necessary to make tight.

5. Pump springs broken or stuck. Replace with new or release if sticking.

6. Pump plunger sticking, dirty or worn. Clean and replace, if necessary, with new plunger.

With Force Feed Systems. (Having separate pumps and pipes.)—

1. Valves out of order. Examine and clean or grind.

2. Pipes leaking pressure or oil. Solder or replace with new pipe.

3. Pumps out of order (see under "circulating systems").

4. Leaks in piping or valves inside of oiler. Solder, pack or replace.

Vacuum Feed Systems—

1. Valve in bottom of tank sticking open or closed at wrong time.

2. Air leaks into tank past cap or other leak. Vacuum feed parts must be kept perfectly tight.

Sight Feeds—

1. Clogged. Take apart and clean.

2. Leaking oil or pressure. Tighten leaky joints or replace gaskets.

Tanks—

1. Leaks in cap, plug or tank proper. Solder or prevent leak.

Drive Troubles—

1. Belt oil soaked or loose.

2. Ratchet has worn teeth. Replace.

3. Pulleys loose on shafts.

4. Worm has worn teeth.

5. Cams worn or loose on shafts.

Oil—

Of poor quality. The worst possible "economy."

Too heavy or too light. Depending on engine type.

Old or dirty. Should be replaced with all fresh supply.

All Oiling Troubles Cause—

Heating, binding, dragging, squeaking, loss of power.

NOISY OPERATION.

Knocking or Pounding—

1. Spark too far advanced. Run it retarded more.
2. Pre-ignition. Firing before top center, caused by red-hot parts or pieces of carbon in cylinder. May come from too rich a mixture, or cylinder may need cleaning of carbon.
3. Connecting rod lower bearing loose. Adjust.
4. Main crankshaft bearing loose. Adjust.
5. Wrist pin bearing loose. Replace bushing.
6. Bearing loose in its cap. Replace or fasten.
7. Motor loose in frame. Tighten bolts.
8. Cylinder loose on crank case. Tighten bolts.
9. Valve strikes spark plug. Use shorter plug.
10. Worn pistons. Put in new ones.
11. Worn cylinders. Rebore and get new pistons.
12. Compression too high. Raise the cylinders by putting a gasket under them on the crank case from one-eighth to three-eighth inch in thickness.
13. Loose flywheel. Tighten bolts, or replace key.
14. Flywheel on wrong. Unbalances the engine.
15. Flywheel wobbles. Straighten.
16. Broken ball or roller bearing. Replace with a new one.
17. Timing gears worn. Replace with new ones.
18. Sprung crank shaft. Straighten in a machine shop.
19. Connecting rod strikes edges of cylinder holes in crank case. File sides of holes larger.

20. Loose pieces in the crank case. Remove.
21. Connecting rod striking some part of crank case. Remove the obstruction.
22. Oil pump clogged or not working. Clean.
23. Timing gears loose on shaft. Fit new keys or keyways.
24. Cam loose on shaft. New shaft or new pins.
25. Loose counter weights. Tighten.

Hissing or Wheezing—

1. Gas leaks around the priming cups, spark plugs, valve caps, or any broken or defective gasket. Replace the gasket.
2. Gas leaks past loose piston. Makes crank case hot. Fit new piston.
3. Gas leaks past broken ring. Makes crank case hot. Fit new ring.
4. Cylinder wall scratched (scored). Rebore cylinders and fit new piston.

Slapping or Threshing—

1. Pistons or cylinders worn. Replace the worn parts.
2. Engine re-assembled wrong. Put parts together right.
3. Worn valve stem guides. Replace the bushings.

Grinding, Scraping, or Grating—

1. Flywheel touches some part. Move whatever is touching.
2. Lack of oil somewhere. Oil.
3. Broken ball or roller bearing. Replace.
4. Worn gear teeth. Replace.
5. Loose wrist pin. (Scrapes cylinder walls.) Tighten.

6. Broken piston ring. (Scrapes cylinder walls.)
Replace.

7. Tight piston rings. File off ends of rings.

Clicking or Rattling—

1. Fan touching other part. Bend the fan or move the other part.

2. Too much valve stem clearance. Change adjustment to thickness of thin card.

3. Metal pieces in the crank case. Remove.

4. Worn valve stem guides. Replace the bushings.

5. Loose or worn valve parts. Replace or tighten.

6. Loose cam shaft bearings. Adjust or replace.

Popping or Spitting—

1. Too weak a mixture. Adjust the carburetor.

2. Inlet closes too late, or the exhaust opens too early.

Squeaking—

1. Lack of oil. Oil.

2. Hot bearings. Oil or grease.

PISTON RING.

D. These are cast iron rings that fit into a slot or groove cut around the outside of the piston. These rings are slit through on one side so that they spring out against the walls of the cylinder and prevent the gas from blowing through between the piston and cylinder. There may be from two to four ring grooves on each piston.

C. The greatest care must be used in removing and replacing the rings inasmuch as they are extremely brittle. Spread them open only enough to slip over the piston. Any more will almost surely result in breakage.

A. New piston rings must be fitted to the cylinder as follows:

First. Clean the slots of all carbon and foreign matter and examine them closely to see that the inside corners are square and that the top and bottom of the slot are parallel to each other and have no taper. If the slots are worn out of shape the piston must be placed in the lathe and the slot turned out to a larger size (one-sixteenth inch wider) than the original size. Never make a size other than one-sixteenth, one-eighth or one-fourth part of an inch; that is, never make a size that has to be measured by thirty-seconds of an inch as it is difficult to secure new rings of these sizes.

Second. Secure a ring of the right width and of the right diameter for the bore of the cylinder.

Third. Without placing the ring over the piston, stick it edgewise in the slot and roll it all the way around the outside of the piston and in the slot. It should fit easily all around, but without play or binding at any point. If it does not fit, file the high spots carefully with a small fine flat file.

Fourth. Carefully spring the ring over the piston and let it drop into the slot. Now try to push the piston into the cylinder. If the ring is too large to let the piston enter, remove the ring from the piston and file a very little from the ends of the ring at the slit on one side, being careful to keep the edges of the slit true and parallel to each other so that when they touch they match exactly.

Fifth. Cover the outside of the ring with a thin coat of Prussian blue and while holding the piston and connecting rod in exactly the position they will occupy when the engine is assembled slide the piston and ring into the cylinder. Do not slide the piston farther than it will travel when in use. Take the piston out again and wherever the blue has been rubbed off dress away a little of the outside surface of the ring with a fine file or piece of emery cloth fastened to a piece of wood.

Sixth. Repeat this operation until almost all of the blue is rubbed off after putting a fresh coat on each time and then follow the same method for each ring needed.

In case an old ring has lost some of its spring and does not touch the cylinder wall at all points gas is allowed to leak past the ring. The places of leakage can be recognized because the outside of the ring will

be dark brown or black at these places. To re-fit an old ring—

First. Carefully remove the ring from the piston and hold the outside surface that touches the cylinder wall on some flat, smooth steel surface.

Second. With a machinist's ball peen hammer strike the inside of the ring a great many very light blows with the ball end of the hammer. Strike so that the part of the ring being struck is exactly between the hammer head and the steel surface and always move

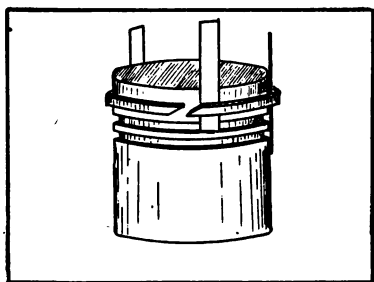

REMOVING PISTON RINGS.

the ring into this position before striking, otherwise the ring will be broken. Strike the ring opposite the point where it is slit and for one or two inches each way from that place.

Third. Watch the opening in the ring while striking and when the slit is open from one-eighth to one-fourth of an inch more than when you started the ring has been spread enough.

Fourth. Fit the ring as directed for new rings.

R. Piston rings are very easily broken in removing and replacing. Lift up one end of the ring with a

small screwdriver until you can slip a thin piece of metal (a piece of old hack saw blade is good) under the ring. This piece should point up and down on the piston and should be slid around the piston until it is directly opposite the opening in the ring and on the opposite side of the piston from the opening.

Now lift the end of the piston ring again very carefully and slip another metal strip under the ring. Leave this piece near the opening and place a third piece under the other end of the ring a little ways from the opening.

By moving the pieces of metal back and forth you can raise the ring entirely out of the groove and you can then slide the ring up on the pieces until it comes off the piston.

To replace the ring open it just enough to slip over the top of the piston and then place the metal strips in the same positions as when you removed the ring. Slide the ring down until it comes to its groove and then take the metal strips out letting the ring into its groove.

Take the top ring off first and replace it last.

POWER, LOSS OF.

If the engine or some of the cylinders have little or no compression—

(a) You can test the compression of each cylinder by turning the starting crank or the flywheel and noticing the resistance as you come to the corresponding stroke of each cylinder.

(b) If the engine has more than one cylinder, open the pet cocks, or remove the spark plugs from all but one cylinder. Then turn the engine over and notice the resistance to turning at one point. The crank or flywheel should spring backward when you let go of it, if the compression is good.

(c) If the crank or flywheel will not spring back but stands still, look for the following troubles:

1. Leaks around the spark plugs. (Test for leaks by putting cylinder oil on the joint and turning the engine over. Bubbles will show leaks.) If the plugs have gaskets, replace with new ones. If the engine uses one-half inch standard plugs, look for broken threads, or cracks, or holes in the part the plug screws into. This will require a new plug, or a new cap.

2. Broken spark plug porcelain. Allows gas to leak out. Put in new porcelain.

3. Spark plug insulation loose. Tighten packing nut slightly.

4. Leaks around valve caps. Put on new gaskets.

5. Leaks around gaskets anywhere near the combustion space. Put on new gaskets.

6. Dirt or carbon on valve face or seat. Take valve out and clean face and seat with fine emery cloth.

7. Valve stem sticking. Remove the valve and clean the stem.

8. Valve stem warped (bent). Test by rolling the stem on a flat surface. Get a new valve and stem.

9. Valve pitted or burned. Grind in.

10. Valve stem broken. Needs new springs, or if out on the road, place a washer between the ends temporarily.

11. Valve head cracked. New valve.

12. Valve seat cracked. New valve cage, or new cylinder casting.

13. Too much space between valve stem and lifter. Adjust to thickness of wrapping paper.

14. Ends of valve lifter, or push rod, worn hollow. Very difficult to locate. New ends or new lifters.

15. Valve adjustments loose (adjusting nuts). Set properly and tighten.

16. Threads stripped on valve adjusting parts. New parts.

17. Valve spring fastenings loose. Tighten, or replace.

18. Shoulder on valve stem. Dress down with fine file or emery cloth until the stem has no ridges.

19. Shoulder on valve face. Dress in a lathe, or with a fine file.

20. Weak valve spring. All the inlet valve springs of one engine should have the same strength, and all the exhaust valve springs should have the same strength. Test the springs by placing them end to end and pressing them together. If one compresses more than another, it should be replaced with a new one or

else have washers placed under it until the strength is equal.

21. Piston ring openings directly opposite one another. Space them evenly around the piston.

22. Piston rings not bearing evenly on the cylinder walls. Cover the outer face of the ring with Prussian blue and push the piston up into the cylinder. Wherever the blue is rubbed off must be dressed down with a very fine file or emery cloth and then tested again until all blue is scraped off. See Piston Rings.

23. Cylinder walls scored (scratched). Rebore, or get new cylinders and new rings.

24. Cylinders cracked. Weld (oxy-acetylene flame), or get new cylinders.

25. Piston head cracked. New piston.

26. Valve stem guides worn loose. New guides or place bushings in guide holes.

27. Valve stem worn. New valve and stem.

28. Timing gears loose on shaft. New keys or keyways. See Timing Gears.

29. Sprung cam shaft. Straighten in a lathe, or get a new one.

30. Worn cams, rollers, roller pins, tappetts, push rods, push rod guides, or cam shaft bearings. New cams, rollers, roller pins, push rod guides, or cam shaft bearings.

It has been taken for granted that the valves are properly timed. This should be the first thing to look at if you have any reason to believe that they are not right. See Valve Timing.

RADIUS ROD.

D. Radius rods are fitted to each side of the car and run from some part of the frame, or part fastened to the frame, to the ends of the axle or axles or points near the axle ends.

Their purpose is to keep the axles parallel to each other and at right angles to the length of the car. In shaft driven cars they are made solid from end to end but in chain drive cars the radius rods are fitted with turnbuckles or clevis or yoke ends so that their length may be adjusted to take up the wear of the chains.

C. Radius rods should be kept straight at all times and they should be fitted so that the front and rear axles are parallel to each other.

A. Radius rods may be adjusted by turning the front wheels until they point straight ahead. Now measure the distance from the front to the rear hubs on each side of the car and lengthen or shorten the rods until this distance is the same on each side.

SPARK AND THROTTLE CONTROL.

D. On the steering wheels of most cars are mounted two short levers which are used to control the amount of throttle opening between the carburetor and cylinders and the spark advance or time during the stroke at which the spark is made to occur in the cylinders. Some cars have only the throttle lever on the wheel, the time of the spark remaining the same at all speeds. Other cars have no levers on the wheel, the spark time remaining constant and the throttle being controlled from a small foot pedal called the "accelerator."

Some cars have a small lever or handle on the steering wheel or steering column for controlling the amount of air admitted to the manifold through extra air inlets, or the proportion of hot and cold air may be regulated by a lever at this point.

These levers and all parts that connect them to the parts they control are classed under "spark and throttle control."

C. Lost motion in these parts is very annoying to the driver and should always be removed as soon as noticeable. It may be caused by the small gears or sectors or arms becoming loose on their shafts or rods. They are held by set screws or by clamping the hub with a screw or bolt. Looseness is also caused by worn pin or bolt holes, loose ball and socket joints or by the levers being so placed on the rods that they work on a dead center without giving any lengthwise movement to the rod they should move.

A. Some cars have the spark retarded and the throttle closed when the hand levers are nearest the driver, this being the commonest arrangement. Others, however, have the spark retarded and the throttle closed with the levers farthest from the driver. Still others have one lever toward the driver, usually the throttle, and the other lever away from him, with the spark retarded and throttle closed.

Usually the short or lower lever will operate the spark advance while the long or upper lever operates the throttle. Other cars, however, have this order just reversed.

If there are three levers on the steering wheel or column one of them will be for admitting extra air to the inlet manifold, for admitting more or less hot air to the carburetor or for operating the electric starting motor.

Before setting any of these levers it will be necessary to find which lever was intended for each operation and what position that lever should be in to retard the spark, close the throttle, shut off the air, etc.

Alterations in these parts may be made by loosening one or more of the small gears or arms under the hood and re-setting the parts before tightening the gear or arm.

The gears or levers, one or more, should be loosened, the spark and throttle levers placed in the retarded and closed positions and the magneto breaker or timer placed in the retarded position and the throttle closed. The gears or levers should then be tightened.

If the car is well designed and the parts properly assembled the spark lever will move from end to end of its travel while the breaker box or timer moves

from fully retarded to fully advanced. The throttle lever will move its full travel while the throttle passes from closed to wide open.

SPRINGS.

D. The springs used for supporting the frame of the car on the axles are almost always made from long flat leaves and are called leaf springs.

According to the shape of the spring or the parts of the spring they are divided into several classes. All classes are denoted by the part of an ellipse that they make. An ellipse is a flattened circle or an oval.

A spring made of two parts placed one over the other and hinged at the ends so that the whole is oval shaped is called a full elliptic spring. One end is on the axle, the other on the frame.

A spring in one piece like one-half of the full-elliptic is called a half-elliptic or semi-elliptic. The axle is under the center of the spring and the frame carried at each end.

A spring formed of a semi-elliptic part with half of another semi-elliptic above it is called a three-quarter elliptic spring. The axle is mounted near the center of the half-elliptic lower part, the end of the upper quarter-elliptic is hinged to the rear end of the lower part, the front of the lower part fastens to the frame and the other end of the upper quarter fastens to the frame.

If the upper part of a three-quarter elliptic spring is longer than one-quarter of the oval the spring is called a seven-eighth elliptic.

Springs formed of half of a semi-elliptic are called quarter-elliptic springs. They carry the axle at the

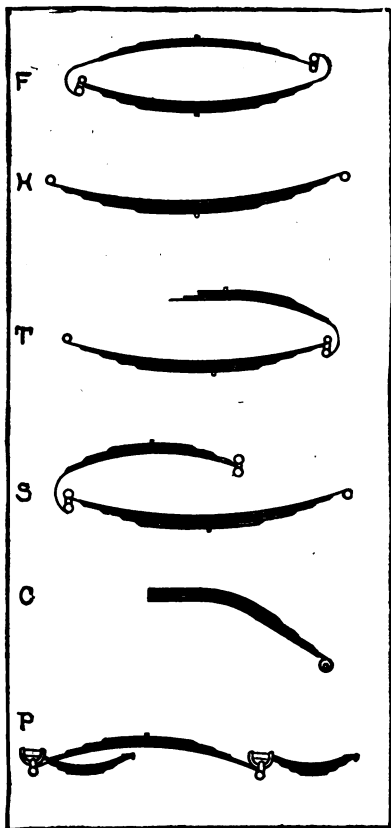

FORMS OF LEAF SPRINGS.

F, Full elliptic; H, Half or semi-elliptic; T, Three-quarter elliptic; S, Seven-eighths elliptic; C, Quarter Elliptic; P, Platform.

thin end and are mounted on the frame at the other end.

A spring that is between a half and a quarter-elliptic in length is called a cantilever spring. It carries the axle at the small or thin end and is fastened to the frame at two points near the other end.

Parts that are used with the springs in mounting are: Spring bolts, the bolts that pass through the ends of the spring. Spring clips, are U shaped pieces, threaded on each leg, that go over the spring with the threaded ends through the axle. They hold the springs to the axles or frame brackets.

Spring brackets are pieces that carry the springs and are fastened to the frame.

Spring eyes are the holes in the ends of the springs through which the bolts pass. They may be formed by simply bending the end of the spring over or they may have brass or bronze bushings.

Spring seats or pads are the parts of the axles to which the springs fasten.

Spring shackles, short pieces with a bolt hole in each end, used for fastening the spring parts together or for swinging the ends of the spring from the frame or brackets.

Front springs are usually semi-elliptic, full-elliptic, or three-quarter-elliptic.

Rear springs are usually three-quarter-elliptic, semi-elliptic, full-elliptic, seven-eighth-elliptic, cantilever or quarter-elliptic, this being the order in which they rank as to number used.

Coil springs are sometimes used to assist the leaf springs.

Auxiliary springs are springs mounted in such a

way that a heavy load brings the frame near enough the axles so that the auxiliary springs touch the axle or frame and come into action.

C. Once or twice in a season the frame should be jacked up so that the springs are relieved of their load, the leaves pried apart with a screwdriver or a special tool bought for the purpose, and a paste made from powdered graphite and oil smeared between the spring leaves.

In replacing springs on the axle or brackets with the use of spring clips place a piece of heavy canvas or duck which has been soaked in white lead and oil between the spring and the part it rests on.

Springs should be examined regularly to discover any broken leaves as it is cheaper to replace one leaf than to wait for the whole spring to break.

T. Broken springs should be replaced with new ones, new leaves being enough if they are not all broken.

In ordering new springs several dimensions must be given. These dimensions should be given as the spring would appear under load, and the load on the spring at the time the dimensions were taken should be mentioned in the letter. The dimensions may be given without load and the load that the spring will have to carry should be mentioned together with the amount that the spring should settle under that load.

- (1) The length of the spring is the distance from the center of one eye to the center of the other eye.
- (2) The width of the spring is the width of the leaves.
- (3) The thickness is the thickness of the whole spring at its thickest point.
- (4) The drop is the distance from a straight line drawn between the centers of the eyes and the seat or pad on which the springs rest. In

some cases the drop is given from the straight line to the top of the spring, although this is not the correct way to measure. (5) The number of leaves, the thickness of the leaves and the thickness of each should be given. (6) At the central part of each spring is a small bolt or else a raised nib for locating the axle and which sinks into a hole in the axle and prevents the spring moving out of place. This nib is not usually in the center of the spring. Its distance from the center of the spring is called the offset. (7) It should also be specified whether the eyes turn up or down at the front and rear end. (8) The diameter of the bolt holes should be given and whether they are to be plain or bushed.

Broken spring leaves may be welded by a skillful blacksmith.

Rattling from around the springs is caused by the bolts not holding the shackles against the sides of the spring eye. This may be corrected by tightening the bolts or by inserting thin washers or shims. The bolts may also be loose in the eyes, requiring new bolts or bushings. The bolts may also be loose in the shackle holes, requiring new shackles or bolts or both. Sometimes the spring seats are clamped around the rear axle housing in two parts. This makes a plain bearing, and should play develop there, it must be treated the same as any other plain bearing.

Squeaks may come from lack of grease in the spring bolt oilers or grease cups, from lack of grease in the rear axle spring seats or it may be between the leaves from lack of graphite paste mentioned above.

STEERING GEAR.

D. The steering gear of a car is composed of a hand wheel for the driver; a steering column; the steering gear proper, composed of gears, racks, worms or other devices for giving a reduction in motion and an increase in power and at the same time changing the rotary motion of the wheel and column to a back and

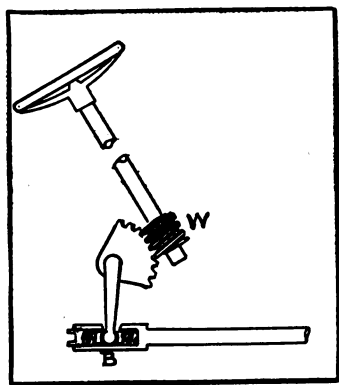

WORM AND SECTOR STEERING GEAR.

Showing spring type of ball and socket joint on end of drag link.

forth motion of the steering drop arm which is fastened to the steering gear proper. To this drop arm is fastened a rod having ball and socket joints or universal joints at each end. This rod is called the drag link when it crosses from one side of the car to the other or a fore and aft rod when it runs straight forward to the axle.

This drag link or fore and aft rod fastens to the steering knuckle arm and this arm is fastened to or made in one piece with the steering knuckle, which is the piece fastened into the end of the axle and which turns with the wheel. The knuckle carries the wheel spindle and also another arm which carries the tie rod arm. This arm is fastened to one end of a rod that runs parallel with the axle from side to side, the other end of the tie rod being fastened to the tie rod arm on the other knuckle.

The steering gear proper is usually composed of a worm carried on the end of the column and mounted on bearings above and below. Meshing with the worm is a worm gear and this worm gear is carried on a shaft which is mounted in bearings in the gear case. One end of this shaft carries the steering drop arm.

This gearing may also be composed of a worm with a sliding nut. The turning of the worm raises and lowers the nut on the threads and this nut moves the drop arm.

Another form is composed of a worm having two threads, one cut left handed and the other right handed. Enclosing this worm are two half nuts, one having a left hand and the other a right hand thread. As the worm is turned one-half of the nut goes up and the other down. They move an arm in one end of the case and this arm moves the drop arm.

Steering gears are also made from a part of a large bevel gear which moves the drop arm, this bevel being turned by a small bevel pinion at the lower end of the column.

Another type uses a rack for the back and forth motion in place of the drop arm, the rack being moved by a small gear on the end of the column.

Still another type of gear has two worms, one with a thread that moves a long ways to each turn, the other moving a short distance, thus giving a reduction in motion.

C. Every joint of every type of steering gear from the hand wheel to the spindles should be kept tight and well lubricated. Every nut and bolt should be locked in place securely.

The housing for the gear proper should have an oil or grease cup and this should be filled once a week. All pins and bearings having grease cups should receive regular attention. The ends of the drag link or fore and aft rod should be kept packed with cup grease and covered with leather boots. The oil holes in the steering column or in the steering hand wheel spider should have a few drops of engine oil daily.

A. Play in the steering parts may come from many causes. It may be in the steering gear proper where adjustment is provided. At the top or bottom of the case where the column comes out is usually a large nut locked in place. Turning this nut, after loosening it, will tighten or loosen the bearings at the top and bottom of the worm on the column.

The shaft carrying the drop arm and its gearing is usually mounted in eccentric bearings that may be turned around after loosening a clamp. This turning throws the gearing into closer mesh and removes some play.

A rack and gear or bevel gear and pinion type have easily recognized means for causing the small gear to mesh tighter into the large one.

A sliding nut has no means of adjustment except renewal.

A right and left hand worm and split nut may be adjusted by placing thin shims between the halves of the nut and the case, throwing the nut tighter into the worm.

Play may also be found in the keys or pins that hold the hand wheel to the column.

The fit of the drop arm on its shaft may not be tight or the nut holding it on may be loose. The clamping nut (when the shaft end of the drop arm is split) may not be drawn tight or may not have enough threads to allow it to draw tight. Keys or pins holding the drop arm to its shaft may also be loose or broken.

The ball and socket joints at each end of the drag link or fore and aft rod may be loose and need to have the ends or plugs screwed farther in or else the parts may be so worn as to require renewal.

The ends of the tie rod have pin and clevis joints in which the pin holes may be worn and need renewal of parts or bushing or the clevises may be loose where they screw onto the tie rod ends.

The fit of the long steering knuckle bolts in the axle ends may be loose in the knuckle itself or more likely in the top or bottom hole in the axle end or yoke.

The steering wheels themselves may also be loose on the spindles and may need the bearings adjusted.

When the steering wheels are turned to point straight forward they should stand exactly parallel to each other. If pointing any other way they should not stand parallel.

To test the wheel position turn either front wheel so that a point opposite the frame at the front edge of the rim and another point opposite the frame but at the rear edge of the rim are each exactly the same dis-

tance from the frame. These measurements should be from the inside or outside of the wood spoke or felloe to the frame, not from the rim or tire.

Leaving this wheel in this position, similar measurements taken on the other front wheel should show exactly equal distances front and rear.

In this position the distance from the center of the left hand front hub to the left hand back hub center should be just the same as from the right hand front hub center to the right hand rear hub center.

If the front wheels do not show equal measurements on each side they may be set by lengthening or shortening the tie rod that runs parallel with the axle either in front of or behind the axle.

One end of this rod should have its clevis or yoke threaded onto the end of the tie rod. Remove the pin from this clevis and screw it on or off the tie rod so that the front or rear of the wheels comes closer together as required, the lengthening or shortening depending on whether the tie rod is in front of, or behind, the axle.

Front wheels out of line will cause hard steering by tending to run toward one side of the road and the tires will be rapidly worn out.

TIRES AND RIMS.

D. Casings are made to fit various types of rims and are called clincher, quick detachable or straight side.

Clincher casings have the edges formed into a projecting lip or bead that is designed to catch and hold in a lip turned in on the edge of the clincher rim. The tire must be stretched over the rim and allowed to drop into place. The air pressure in the tire forces the bead of the tire tightly into the clinch of the rim. Inasmuch as this type of tire must pass over the rim by stretching, it is always necessary to order "Clincher Casings" for solid one piece clincher rims. This type is made with a soft bead that will stretch.

Quick detachable casings have the same shape and form of bead as the clincher, but the "Q. D." casing bead will not stretch. Quick detachable rims are made in two or three pieces, the principal piece being the broad flat rim proper that is fastened to the wheel. The other parts are in the form of rings that carry the curve of the clinching lip. This ring is usually held on by another ring outside of it that drops into a groove or locks by some special means. The small rings are removed while the tire is slipped over the main part of the rim, the locking and clinch rims then being replaced. The air pressure in the tire holds the rim parts in place. This "Q. D." rim will take the clincher or "Q. D." casings.

To avoid the cutting action of the rather sharp edge of the clincher rim another form has been developed

which is known as the straight side tire. This type of tire has the sides coming straight down without any clinching bead. The edge or bead of this tire is made very strong so that it will not stretch a particle. This type is slid over the main part of the rim just like a "Q. D." type and the rings hold it in place with the help of the air pressure. This type depends on the

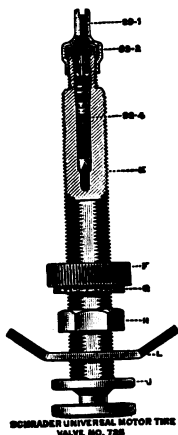

STANDARD FORM OF AIR VALVE FOR AUTOMOBILE TIRES.

strength of the tire against stretching to prevent being blown over the rings.

Rims are made with rings having a clinch on one side and straight or only slightly curved on the other side. These are called Universal rims. The rings on both sides of the rim are removable and by taking them off and turning them around either a clincher, "Q. D.," or straight side tire may be used.

Demountable rims are made in such a way that the entire metal rim and rings that carry the tire fully

pumped up may be removed from another inner rim. The rim that carries the tire is bolted or clamped to the inner rim which is fast to the wheel.

C. To keep tires in good condition and to secure their full mileage the following rules should be observed:



GAUGE FOR TESTING THE PRESSURE IN AUTOMOBILE TIRES.

Keep them pumped up to the following pressures:

	Front Tires.	Rear Tires.
3 inch Tires	55 pounds	60 pounds
3½ " "	63 " "	70 " "
4 " "	70 " "	80 " "
4½ " "	80 " "	90 " "
5 " "	90 " "	100 " "

• Do not run them rubbing the curb.

Do not run in deep or hard ruts. †

Do not let them stand in oil or grease.

Do not expose extra tires to light or cold unnecessarily.

Do not start or stop with a jerk.

Do not run in or on the car rails.

Do not overload above the following total weight of car less passengers for each tire:

3 in. tires—350 lbs.	4 x32 in. tires—650 lbs.
3½x30 " " —450 "	4 x34 " " —700 "
3½x32 " " —555 "	4 x36 " " —750 "
3½x34 " " —600 "	4½x32 " " —700 "
3½x36 " " —600 "	4½x34 " " —800 "
4 x30 " " —550 "	4½x36 " " —900 "

Run slowly over rough or stony roads.

Repair small cuts immediately.

T. Cuts in the tread of the tire come from running over sharp stones, pieces of metal, crockery, glass, nails, etc., or from running in the car tracks.

Stone bruises are caused by striking large obstructions with more or less force, such as rocks, bumps, curbs, etc. This breaks the fabric inside the tire but does not show on the outside until one or two hundred miles later, when the bruise causes a bad blow-out.

Blow-outs are caused by cheap or defective tires, stone bruises or from not observing the rules given above.

Rim cutting is caused by running the tires with too little pressure.

Tread wear comes from long use, from standing in oil or grease, from being exposed to extreme heat or cold, from fast running and quick starts and stops or from the wheels being out of line.

Loose treads come from having skid chains fastened too tight, from turning corners too fast and from under inflation.

From an examination of 1,000 damaged tires the following percentages of causes were discovered:

Wear and tear in use.....	37%
Punctures	28%
Too little pressure.....	17%
Stone bruises and small cuts.....	11%
Rusty and bent rims.....	4%
Stopping too suddenly.....	2%
Standing in oil or grease.....	1%

It can thus be seen that care would prevent more than one-third of the tire troubles.

See Vulcanizing.

TORSION ROD.

D. This is a rod or shaft or brace that prevents the rear axle housing from revolving. When power is applied to the road wheels the tendency is for the wheel to stand still and for the axle housing to turn around. If the axle cannot turn the wheel will revolve and the car will move. The torsion rod thus takes the whole strain of driving the car. It is usually mounted rigidly on the axle housing near the center and has a spring or slightly flexible joint at the other end where it is fastened to the frame or some part which is carried on the frame.

The torsion strain is often taken on the housing which is around the driving shaft from the transmission. This housing is then called the torsion tube.

TRANSMISSION.

Between the gasoline engine and the roadwheels will always be found some means of changing the relative speed of the engine and road wheels. This part is called the change speed gearing and may be made in a number of forms. The change speed gearing gives several speeds forward and one reverse.

The types of transmission or change speed gearing in common use are the sliding gear type, the planetary and the friction. Hydraulic transmissions using oil circulated by pumps and electric transmissions are also used.

Sliding gear transmissions have several pairs of gears on parallel shafts arranged so that one set of gears may be slid along one of the shafts until they mesh with others, giving the desired ratio of speed, forward or reverse. Sliding gear transmissions are divided into selective (the most common of all types) and progressive. Selective sliding gear transmissions are made in such a way that the operator may pass from any speed to any other speed without the necessity of passing through other speeds between. The progressive type is made in such a way that the gears must pass from the lowest speed to the next highest, then to the highest and in order to return to the lowest or to reach reverse the intermediate speeds must be passed through.

The planetary transmission has sets of gears rotating around a central gear in such a way that hold-

ing the axles of the set of gears stationary, or holding an enclosing ring gear stationary, or allowing the whole mechanism to revolve as a unit, will give a low forward speed, a reverse speed or high speed, respectively.

The friction transmission is made with a large driving wheel fastened to the engine and turning with the crank shaft. Placed edgewise against this is another wheel. Pressing the second wheel against the first one causes the second wheel to revolve at various speeds, depending on its distance from the center of the driving disc when they are pressed together.

Sliding Gear. C. The gearing is enclosed in a case which contains the oil or grease for lubrication and prevents dirt from getting to the gears. If the transmission case is separated from the clutch and crank case completely so that no oil or grease can pass from one case to the other and if the transmission is fitted with ball or roller bearings a light weight transmission grease should be used. A heavy grease or fibre grease might be used if the transmission is badly worn and noisy. If no light grease can be secured mix the heavier grease with enough cylinder oil to thin it.

If the transmission case is in any way connected with the clutch or crank case or if it is fitted with plain bearings nothing but cylinder oil should be used.

The transmission case should be filled with grease or oil only to the level of the lower gear shaft, no higher than this under any circumstances.

The covers and joints in transmission cases should be carefully gasketed with shellaced gaskets and the bearings should have well fitting packing washers or

covers so that grease or oil cannot leak out of the case in any way.

By referring to the cuts of the selective sliding gear transmission, its action will be clearly understood. The left hand upper gear of the pair (C-C) is fastened to the left hand shaft which comes from the clutch. This gear drives the lower one which is always in mesh with it, causing the countershaft to turn whenever the clutch is engaged with the engine running.

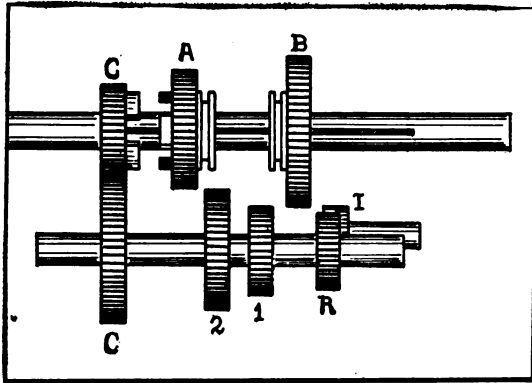

SELECTIVE SLIDING GEAR TRANSMISSION.
(Vertical or Horizontal Section.)

The right and left hand ends of the upper shaft have no connection, the division coming at a point under the gear (C). The right hand end is keyed or splined, and carries the sliding gears (A) and (B). Gears (2), (1) and (R) are fastened tightly to the lower or countershaft and always turn with it, remaining in the positions shown. The small gear (I) meshes with (R) at all times, as shown by the end elevation, and will also mesh with (B) when (B) is moved to the

right. (R) is not large enough to mesh with (B) directly.

To secure a low forward speed the gear (B) is slid to the left into mesh with (1) causing the drive to come through (C-C) with a reduction in speed and from (1) to (B) with a further reduction, driving the right hand end of the keyed shaft which is connected to the rear axle.

To secure an intermediate speed the gear (B) is returned to the neutral position as shown and the gear

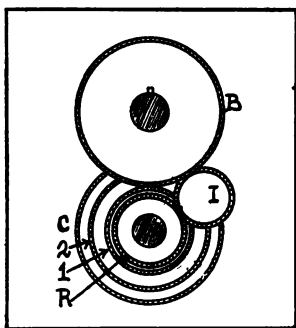

SELECTIVE SLIDING GEAR TRANSMISSION.
(End Elevation.)

(A) is slid to the right, meshing with (2), and causing the drive to come through (C-C) and from (2) to (A), giving only the reduction between (C-C).

To secure high speed or direct drive the gear (A) is slid to the left until the jaws on its face engage with the jaws on the gear (C), thus locking (A) and (C) together and causing both ends of the top shaft to turn together at the same speed.

To secure reverse, the gear (B) is slid to the right,

engaging with (I) and causing the drive to come through the gears (C-C) and from (R) into (I) at

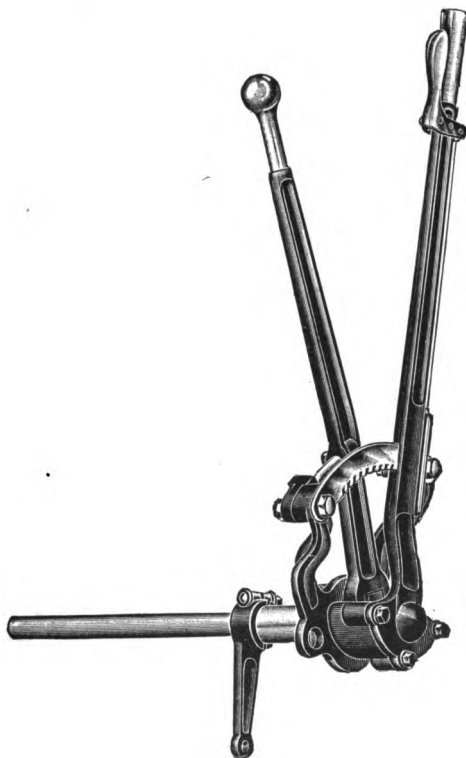

EMERGENCY BRAKE HAND LEVER AND GEAR SHIFT
HAND LEVER.

The short arm below is operated by the brake lever, the cross shaft operating the transmission gears.

which point the direction of motion is reversed by inserting the idler gear (I) making one more gear in mesh than in the other positions. The drive passes

from (I) into (B), causing the drive or keyed shaft to turn slowly in a reverse direction.

A. Gears are shifted to secure the various speeds by means of forks or yokes which fit into a slot or groove cut around the gear hub. These forks or yokes are moved by being fastened to rods that pass out through the transmission case. The position of the yokes on the rods is usually adjustable by screw threads or other means, these threads being in the yoke so that the rod may be screwed through it or else on the outer end of the rod so that the parts that operate the rod may be screwed on or off the outer end of the rod.

In the shifting rods will be found notches and in the case will be holes that carry a steel ball or plunger and a spring that presses the ball or plunger into the notch on the rod. These notches are in such positions that when the gears are meshed in any certain pair or ratio they will be held in full mesh by the plunger or ball dropping into the notch, until forcibly changed to another position by moving the rod. The part carrying the plunger or ball is not always in the case itself but may be in some separate part which is attached to the case. The threaded parts may be any place between the fork itself and the hand lever operated by the driver.

With the hand gear shift lever placed in position to give one of the speeds, the gears in the transmission that produce this speed should be in full mesh, that is, the teeth of one gear should extend all the way along the teeth of the other gear so that a ruler laid across one gear will touch the other gear all the way across. If the gears are not in this position you

should change them with the adjustment mentioned above until they are exactly right.

In placing the transmission in the frame it must be tested before bolting down to see that the center of the shaft going to the clutch is exactly opposite the center of the rear end of the crank shaft. The shaft coming from the rear end of the transmission should have its center exactly on the center line of the frame or in a vertical line passing through the center line of the frame.

T. One of the commonest troubles of sliding gear transmissions is that the gears do not stay in proper mesh while running.

If the gears will not stay in low, second or reverse speeds examine the ball or plunger and notches in the shifter rods described under **(A)**. If this lock does not hold the rod quite tightly in place the gears will be forced out of mesh.

If the gears will not stay in high speed it may be for the same reason given above or else because the clutch jaws or gear teeth that lock together to give high speed are worn rounding so that they have not a secure hold or grip between the two parts that slide together. The only sure remedy is new parts, although a latch or spring catch may be fastened to the hand lever that will hold this lever in the high speed position.

In some forms of mechanism there may be difficulty in returning the hand gear shift lever to the neutral position or else it may be found impossible to pass from neutral into one of the-speeds.

If the hand lever moves in an H-shaped slot it may be found that one of the small flat springs fastened to

the short levers under the H plate does not enter the cross slot of the H and consequently allows the small levers to move out of place so far that the hand lever cannot catch them to make the shift. These springs may be loose, broken, bent or twisted.

If there are no springs or short levers under the H plate the trouble will be in the parts enclosed with the transmission case and the case will have to be opened. This trouble inside the case will probably be caused by the small locking plungers not holding the shifter rods in proper position for the hand lever to move from one rod to another.

In case new sliding gears have to be fitted to the old shafts it will often be found that the new gears will not slide along the shaft properly. To make them slide, cover the surface of the shaft with a mixture of fine emery powder and thin oil. Work the gear back and forth over the emery and oil until the gear moves freely enough for easy shifting.

A noisy sliding gear transmission may be caused by lack of oil or grease; by the transmission case frame bolts being loose; by loose bearings; worn or broken gears or gear teeth or by bent, twisted or sprung shafts.

Sprung shafts will give an irregular grinding noise and will probably cause hard gear shifting. This condition may possibly be seen by looking into the transmission while someone else turns the engine slowly by hand, but to make sure it will usually be necessary to remove the shafts and place them between the lathe centers for test.

Planetary. D. The ordinary planetary type of change speed gear is made by attaching a shaft carrying two spur gears to the engine so that this shaft with

its gears turns with the engine. Placed around each of the two gears are three gears which are always in mesh with the shaft gears. These outer gears are in a ring around the inner gear and are carried on pins which are fastened to plates. These plates have metal drums around their outer edge, these drums forming a cylindrical case for the transmission. One set of the

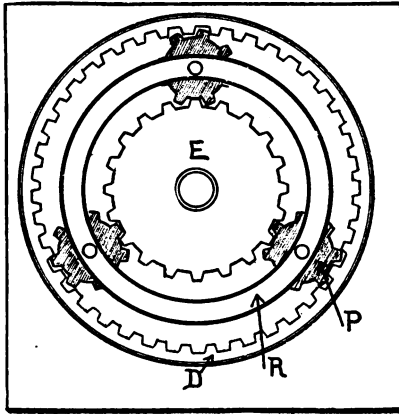

PRINCIPLE OF THE PLANETARY TRANSMISSION.

E, Gear driven from engine; P, Pinion meshing with the engine gear and with the outside internal tooth gear D; D, Internal toothed gear, which, when held stationary, with E turning, causes the pinions P to carry R slowly in the same direction that E turns, giving low speed forward; R, Ring carrying the pinions, which, when held stationary with E turning, causes D to travel slowly in the opposite direction to that in which E turns, giving reverse speed.

outer gears also mesh into internal teeth cut on the inside of their drum.

By preventing the internal gear drum from turning, the shaft from the transmission moves slower in the same direction as the engine shaft, giving a slow speed forward; preventing the other drum from turning causes the rear shaft to turn slowly in the opposite di-

rection, giving a reverse speed. High speed is secured by having a form of cone, plate or disc clutch at one end of the transmission, which causes the driven shaft to turn at the same speed as the engine shaft, giving high speed forward.

The Ford and some other makes of planetary gearing have no internal gears but secure the same operation by having all spur gears, mounted on several tubes operating on the outside of a shaft, the drums being carried at one end and the gears at the other end of the tubes.

C. When planetary transmissions are not carried in an oil-tight case outside of the drums, the drum should be filled with heavy transmission grease or cup grease through a hole closed by a small screw plug in the end of the case or between the drums.

When there is an outside oil-tight case this should be filled just deep enough to cover the lower inch or so of the planetary drums with cylinder oil.

Inasmuch as a planetary transmission operates by having brake bands which stop the drums from turning, no form of graphite or grease must ever be used in a planetary of any form because of the danger of its getting onto the drums or brakes.

A. The bands around the drums will wear and loosen with use in the same way that brake bands will wear and loosen. There is always some means of drawing the bands tighter around the drums by screws and nuts or bolts at the ends of the bands or by adjustable clevises or yokes in the operating rods. There will be a form of screw or cam adjustment at some point between the ends of the bands at the transmission and the pedals or levers that are operated by the driver.

When the facing is worn from the bands it may be replaced in the same way that brake-band facing is replaced.

Some bands are made from cast iron and when these wear out they must be replaced with new ones.

R. When it is desired to remove a planetary transmission the first thing to do is to disconnect all parts that operate the bands or the high speed clutch and if the transmission is not enclosed in a case it will be best to remove the bands to prevent their being jammed out of shape.

The flanges or universal joints at each end of the transmission should then be disconnected, releasing the transmission from the drive shaft or chains and from the engine.

If the transmission is not enclosed it may then be taken out, but if enclosed the case, or case cover, may be removed and if possible the transmission lifted out of the case. Oftentimes the case divides at the center line besides having a cover on top. It will, of course, be necessary to take the case apart at the center.

To remove the Ford planetary transmission first remove the aluminum cover over the flywheel and transmission by taking out all the bolts around the center dividing line between the upper and lower half of the case. This top may then be lifted off with the pedals and high speed operating yoke. Next, disconnect the universal back of the transmission case by driving out the pin through the hole in the casing or else loosen the rear axle from the cross spring and brake rods and draw the axle back while the frame of the car is blocked up. This will draw the square end of the drive shaft out of the universal and leave the transmission free at the rear.

The transmission is still bolted to the engine and the easiest way to release it is to remove all the bolts around the joint between the upper and lower halves of the engine crank case, remove the spark plug wires and take off the cylinder head, take off the rods from the steering column to the timer and carburetor, remove the radiator and lift the cylinders out with the crank shaft, pistons, rods, magneto, transmission and clutch, all in one unit.

Now turn the engine upside down on a stand and take out the bolts that fasten the transmission and magneto magnets to the end of the crank shaft.

T. Any planetary transmission will be more or less noisy in low and reverse speeds but if the transmission should make a great deal more noise than when new it may be due to wear in the bearings, pins, bushings or gears. The only way is to examine each moving part for wear and replace those that are in bad shape.

A planetary transmission may sometimes be made more quiet by taking it apart and replacing some or all of the gears and bushings in different positions so that they are in different relation to each other. This distributes the wear.

Should the bands touch the drums continually, or drag, the bands will heat badly and a great deal of power will be lost and noise produced. This dragging may be caused by too tight an adjustment; by small springs between the ends of the bands not holding the ends apart; by the operating rods, levers or yokes binding; by the bands coming loose from the parts that carry their weight; because the bands are dirty or because the bands have become bent or out of round. The remedy is evident in each case.

If the transmission does not hold and deliver full power to the road wheels in low or reverse, it is because the bands do not hold tight enough. The bands may not be adjusted tight enough or the facing may be dirty or worn out or covered with grease or oil. The bands may have been bent out of round or they may be loose from their supports or the pull rods. The operating parts may have so much wear or play that they do not draw the bands tight, the adjusting bolts or pull rods may have stripped threads or there may be something under the band or between the ends that prevents it from clamping tight around the drum.

Should the high speed clutch give trouble it may be remedied according to the type of clutch—plate, disc or cone.

Friction. D. Friction transmission shafts are carried on extra large bearings because of the very heavy loads produced by the holding of the wheels in contact to give the necessary driving power.

The disc driven by the engine usually has its face or driving side made separately from the balance of the wheel. This face is made from a material having good wearing qualities and may be bolted, screwed or riveted to the main body of the wheel. It should last almost as long as the car unless badly misused by applying too great pressure or by excessive slipping.

The wheel driven by the engine disc is made with a grooved rim and into this groove fits a paper or fibre ring that provides the necessary friction when in contact with the first disc. This fibre or paper filler is bolted into the rim and may be easily and cheaply replaced when worn out.

C. There is a great side strain or bending load on the

bearings in a friction transmission and for this reason the bearings on all the shafts must receive a continuous supply of grease or oil, attention being given each bearing every day the car is run.

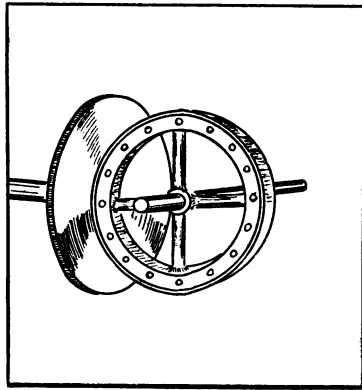

FRICION CHANGE SPEED GEARING.

If a friction transmission is allowed to remain on the neutral point with the engine running and the discs pressed together, a flat spot will be worn on the driven wheel. Flatness may also be caused by having the car stalled on a hill or in mud or sand, with the transmission working in low or reverse without moving the car. These flat spots afterwards cause a heavy bump whenever the car is run.

The hand lever and discs should not be run in any one position steadily, as this wears deep grooves in the driving disc. By using various positions this is prevented. Deep grooves in this disc make it difficult to move the driven wheel for speed changes.

In driving a car having a friction transmission do not

place excessive pressure on the pedal or lever to make the disc hold. There should be just enough pressure applied to make the discs drive without slipping; more than this wears the bearings and discs and makes the engine work harder and yet the car has less power and speed than with moderate pressure.

The contact surfaces of the engine disc and of the friction wheel must be kept clean and dry at all times. They should also be as smooth as possible, because two smooth surfaces have greater friction on each other than two rough surfaces, as may be proven by laying a piece of window glass on another piece and trying to move one over the other.

T. A slight looseness or play in the bearings of a friction transmission will do no great harm and may be neglected.

Should the friction wheel develop bumps they may be removed by grinding off with an emery wheel but a new filler is best. Grooves in the engine disc may be dressed off in the lathe or a new surface may be fitted to the body of the wheel.

If the transmission works itself into the high speed position while in use, it is because either one or both of the friction wheels are worn to a slant or bevel or their bearings are loose. If the surfaces are made true and bearings tightened, this tendency will disappear.

TWO-CYCLE ENGINE.

Two-Port. D. The two-cycle or two-stroke cycle engine performs the operations of inlet or suction, compression, explosion and exhaust in one revolution of the crank shaft in place of in two revolutions, as in the four-cycle engine.

The two-cycle engine has no mechanically operated valves or valve operating parts, the only moving parts of the engine being the piston, connecting rod, crank shaft and a suction-operated valve.

The fresh gas is compressed in the crank case until it has pressure enough to enter the cylinder at the end of the power stroke when the piston is at the bottom of its travel. The piston then makes its up stroke, compressing the gas further in the cylinder, until, at the upper end of the stroke, the gas is fired by the spark. The piston then goes down, and when near the end of the power stroke, the burned gas is allowed to escape. Immediately afterward, before the piston starts up, more fresh gas enters from the crank case while under pressure.

The cylinder is entirely closed at its upper end, having no openings as has the four-cycle engine. The crank case is made gas tight and the carburetor opens into the crank case in place of into the cylinder. Between the carburetor and the crank case is an automatic check valve which can open freely to allow gas to pass from the carburetor to the crank case, but should the gas attempt to return to the carburetor, this

valve seats and prevents the return of the gas. The valve is held on its seat by a light coil spring and is sucked open when the piston goes up into the cylinder.

Let us consider that the piston is at the bottom of its stroke or nearest the crank case and that it is caused to go up by the turning of the crank shaft.

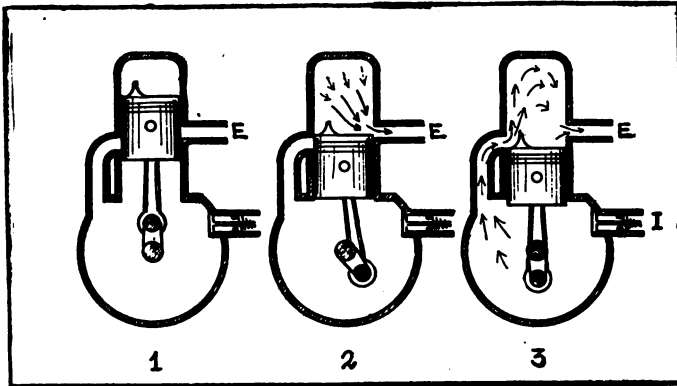

TWO PORT, TWO CYCLE ENGINE.

1, Piston at top of stroke, ready to fire in cylinder and compress gas in the crank case; 2, End of the firing stroke with gas passing out exhaust port; 3, Lower end of piston travel, admitting compressed gas to cylinder.

As the piston goes up the space in the crank case below the piston gets larger and to fill this space the carburetor check valve opens and a charge of fresh gas comes from the carburetor, filling the crank case.

When the piston reaches the top of its stroke there is no more suction in the crank case and the valve spring closes the valve. The piston then starts down and as the gas cannot escape from the crank case it is compressed. When the piston reaches a point almost at the lower end of its stroke the top of the piston passes below and uncovers a hole or port in the cylinder wall.

This hole connects to the crank case by a pipe called a by-pass or transfer pipe. The gas being in the crank case under pressure now rushes through this by-pass and through the hole into the cylinder, filling the cylinder with fresh gas.

As the piston starts up it covers the hole leading into the crank case and as the gas cannot escape it is compressed. The upward movement of the piston also draws more fresh gas into the crank case.

At the top of the stroke the gas is fired the same as in a four-cycle engine and the expanding gas forces the piston down on the power stroke. At the same time the gas drawn into the crank case is being compressed by this downward movement of the piston. When the piston has completed about five-sixths of the power stroke (but before the hole leading into the crank case is uncovered), the top of the piston passes below and uncovers another hole in the other side of the cylinder wall, this hole being a little ways above the inlet by-pass port. This second hole or port connects with the exhaust piping and the burned gas immediately rushes out of this opening into the exhaust pipe and muffler.

The piston continues to go down and uncovers the inlet port so that more fresh gas comes in from the crank case. This fresh gas strikes a ridge on top of the piston head just as it comes through the port. This ridge is called a deflector and is curved so that it sends the fresh gas toward the top of the cylinder while the burned gas is still going out the hole on the other side. This fresh gas helps to blow the rest of the exhaust gas out and the piston starting up closes both ports and compresses the charge for another power stroke.

In the inlet by-pass there is a screen of wire mesh

that the fresh gas must come through. It is impossible for fire to pass through a wire screen and this makes it impossible for the burning gas in the cylinder to set fire to the fresh gas in the crank case. This is called the by-pass screen.

C. The greatest care must be used to see that there are no leaks into or out of the crank case or the cylinder. This makes it important to keep the crank case joints, gaskets and bearings perfectly tight to avoid this leakage.

It must be noted that the by-pass screen is not broken and has no holes or there may be an explosion of gas in the crank case.

Two-cycle engines require plenty of good oil and efficient cooling systems as they heat much easier than the four-cycle.

Inasmuch as the two-cycle engine uses the crank case for gas, the oiling of the engine is done by mixing from one pint to one quart of cylinder oil with the gasoline while it is in the gasoline tank. This oil then passes through the carburetor into the crank case and oils all the moving parts.

R. The same care in removing cylinders and pistons and bearings is required by the two-cycle engine as is required for any other type, but there will be no valves to time nor cam shafts or valve timing gears.

The thing to make sure of is, that every joint on the engine is absolutely tight when replaced.

T. When a two-cycle motor is running without moving the car it will almost always miss explosions. The two-cycle motor has a very limited range of speed and will miss explosions when running very fast or very slow or with the throttle nearly closed. This missing

will be impossible to avoid. If the engine pulls well and fires evenly while handling the car under ordinary conditions, it is working satisfactorily.

Two-cycle motors require more careful carburetor adjustment than the four-cycle type and it will be necessary to adjust the carburetor more often to allow for weather changes.

The same ignition and carburetor and cooling troubles occur as in any other type of engine. It should be remembered that a spark is required every time the piston comes to the top of its stroke.

The only troubles that occur especially in two-cycle engines come from leaky joints and if these joints and the bearings are all tight but little trouble will develop and most troubles that were hard to locate will disappear.

Three-Port. D. The two-port two-cycle engine is not really a valveless engine because an automatic check valve is required in the crank case to prevent gas passing back into the carburetor.

The three-port engine is really valveless and differs from the two-port in only one way.

The carburetor pipe does not lead directly into the crank case, but leads to a third port in the cylinder wall. This port is so far down on the cylinder wall that it is uncovered only when the piston is at the upper end of its stroke. It is uncovered by the lower edge of the piston passing upward.

Inasmuch as the lower edge of the piston passes up and opens this port it will be seen that this port is then opening into the crank case. The upward movement of the piston causes a vacuum in the crank case and as soon as this inlet port is uncovered the fresh gas from

the carburetor rushes into the crank case to fill up the space caused by the piston going up.

When the piston starts down, the lower edge of the piston immediately covers this inlet port, and the gas, being unable to escape until the piston gets to the bottom and uncovers the by-pass port, is compressed in the crank case in the same way as in the two-port.

No form of two-cycle engine is as economical of gasoline as a four-cycle engine. This is true for several reasons.

The burned gas is not entirely cleaned out of the cylinder, some part of it always remaining and this mixes with the fresh gas and weakens its power.

At high engine speeds the fresh gas does not have time to completely fill the cylinder, neither does the burned gas have time to properly escape. This is one of the reasons a two-cycle engine will not run very fast.

At slow speeds the throttle will be nearly closed and the suction in the crank case is not enough to draw a full charge of fresh gas through this small throttle opening, the result being that the smaller charge of fresh gas cannot give full power.

A two-cycle engine gives more power for the number of cylinders and the weight of the engine and a three-cylinder two-cycle engine gives as steady power impulses as a six-cylinder four-cycle engine. A two-cylinder two-cycle gives the same number of impulses per revolution of the crank shaft as a four-cylinder four-cycle. The two-cycle is much less complicated than the four-cycle in any form.

Differential Piston. D. This type of two-cycle engine has a piston with the lower part larger around than the upper part. The cylinder has its lower part larger

than the upper. This practically makes two pistons and cylinders in one. The upper or regular cylinder burns the gas in the same way as the two and three-port types but the gas is compressed in the lower part of the cylinder by the projection on the piston, acting as a pump. This compressed gas then passes through

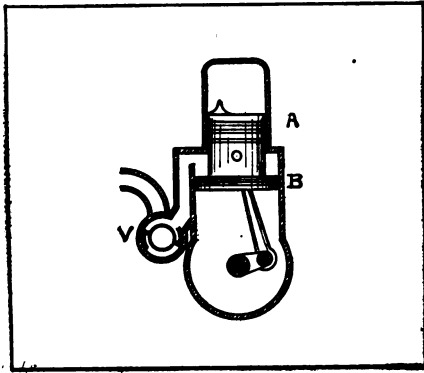

DIFFERENTIAL PISTON, TWO CYCLE ENGINE.

A, Small diameter firing portion; B, Large diameter compressing portion;
V, Rotating valve.

a rotary valve in the crank case to the upper end of the adjoining cylinder which is ready to compress.

C. This type requires that all cylinder joints be tight, but the crank case may be neglected. It is, however, necessary that the long rotary valve be kept tight and that the by-pass screens do not leak.

UNIVERSAL JOINT.

D. Joints that allow power to be carried from one shaft to another when the shafts run at an angle to each other are called universals or universal joints.

Universals are usually made with some form of clevis or yoke on the end of each shaft to be joined ; and, with these clevises at right angles to each other, a square, cross, or solid block is inserted between the clevis ends and fastened with pins passing part way or all the way through the clevis ends and the block.

Another form of universal joint is made by fastening flanges to the ends of both shafts to be joined and connecting these flanges with a flat piece of leather and bolts or with a leather belt and pins.

C. Universal joints must be kept packed with cup grease and covered with leather housings or boots or with metal cases to exclude the dirt. The pins and blocks must also be renewed if badly worn or very loose. Leather universals should have the leather treated with neatsfoot or castor oil once a month.

Metal universals require attention and greasing every 1,000 to 2,000 miles.

R. To take a universal apart, first remove the leather or metal sleeve or cover, or if it is leather type universal simply unbolt the leather and slip the parts away from each other, allowing the leather to drop off.

If the universal is made with metal pins the pins must be withdrawn. There may be two pins going straight through or four pins, each one sticking part way

through. These pins are held in place with smaller pins, nuts, bolts, clamps or screws and in some types only by the metal covering around the joint. After unlocking the pins they may be drawn or driven out one way or the other, allowing the joint to come apart.

VALVES.

D. Valves are used in the automobile engine for admitting the fresh gas to the cylinders and allowing the burned gas to leave the cylinders at the proper time during the stroke of the piston.

There are several types of valves in use for this work, all opening into the combustion space of the cylinder. Poppett valves have a flat or cup-shaped head attached to a long stem. The head closes a round hole in the cylinder so that the gas cannot escape.

The face of the valve is the part that touches the metal of the cylinder or of the cage carrying the valve, making a tight joint. The seat is the part of the cylinder or of the cage carrying the valve, which the face comes against to make the joint. Valve lifters, plungers or tappets are the parts between the valve stems and the cams that help to open the valves. Valve springs are fastened to the stem to close the valve when not held open by the cam. Valve stem guides are the holes through which the stem passes.

Sleeve valves are sections of tubing that fit between the piston and cylinder. There are one or two of these thin tubes, having holes through it near the upper end. These sleeves or tubes are arranged to move up and down by being connected to a shaft with small connecting rods. This shaft is called an eccentric shaft and is driven from the crank shaft much like a cam shaft. As the sleeves move up and down, the holes come opposite each other and at the same time opposite

a hole in the cylinder wall so that the gas is allowed to come into or leave the cylinder at the right time.

Rotary valves are made from a long shaft having holes crosswise through it. This shaft is contained in a hole having openings leading from the sides of the hole to the cylinders and to the carburetor and exhaust manifold. The long shaft in turning brings its holes so that the carburetor openings or exhaust openings are temporarily connected to the cylinders, allowing the gases to be admitted or expelled at the proper time. The valve shaft is driven from the crank shaft in the same way that a cam shaft might be driven.

R. To remove poppet valves from their cylinders first loosen the lower end of the valve spring from the lower end of the valve stem. To do this, pry the spring up from the bottom so that the end of the spring is held above the end of the stem. To accomplish this you will have to remove the cap that is screwed into the cylinder casting above the valve, and, reaching through this opening, hold the head of the valve down on the seat with a screw driver, hammer handle or block of wood.

The spring may be lifted up by a valve-spring lifter or in many cases with an ordinary screw driver resting on some solid portion of the engine or bench. After the spring is pried up out of the way you can take off the washer, nut or key from the lower end of the stem and slide the valve up through its spring and out of the opening above the head.

T. To grind poppet valves to a good fit—

1. Remove all carbon or soot from the valve stem and see that all ridges or projections on the stem are filed off.

2. Examine the face and seat of the valve and if they are pitted or rough or have slight holes or depressions, they need grinding.

3. Valves are ground by placing valve-grinding paste between the face and the seat and then rubbing the valve on the seat. The valve-grinding material is made into a rather thin paste and a small quantity of the paste is placed on the face and spread around evenly. As much grinding material as can be picked up on the tip of a pocket-knife blade is sufficient.

4. Now take a cloth (not a piece of waste) and tie a string or piece of wire to the cloth and stuff it into the opening from the valve pocket into the cylinder proper. This prevents the grinding compound from entering the cylinder.

5. On the top of the valve head there is usually a slot or holes that take the end of a screwdriver or forked valve-grinding tool. If there are no holes or slots on top of the valve there will be a hole through the lower part of the valve stem. These are used to turn the valve on its seat, the slot or holes being used with a screwdriver or special tool. A nail or small rod is stuck through the hole in the valve stem so that a hand-hold may be had on the valve.

6. Place the valve in its place in the cylinder and start grinding by turning the valve about half way around and then back again. Do this several times, using but little pressure. Too much pressure forces the grinding paste from between the valve and seat and makes slow work.

7. After making several half turns in alternate directions, the valves must be raised and placed back in a new position. In order to raise the valve from the seat

you can push up from below on the valve stem, or else place a small light spring around the valve stem under the head so that the valve is held a little ways above the seat. When you press down in grinding, the valve is forced down onto the seat, but when you release the pressure, the valve will rise again.

8. After grinding for a few minutes take the valve out and wash the face with gasoline or kerosene. If the face is a clean, even gray all around and has no marks, pits or spots, the job is finished and the valve should be gas-tight.

To test the seating of the valve after grinding, place pencil marks at short distances around the face, then place the valve on its seat and turn once around with considerable pressure. The marks should all be rubbed off if the valve is tight.

Gasoline or kerosene can be poured on top of the valve, which will not leak through if the seating is correct.

Great care must be used that every trace of the grinding material is washed from the valve and from the seat and edge of the pocket before removing the cloth from the cylinder hole.

Valve-grinding paste for starting the work may be made from a mixture of medium emery powder and kerosene or light oil or vaseline. To finish the work use fine emery powder and light oil or vaseline, or powdered glass mixed with light oil or kerosene.

Timing Poppett Valves. There are usually markings on the flywheel indicating when the inlet and exhaust valve should open and close.

These markings are in the form of lines cut across or on the edge of the rim of the flywheel.

A line should be brought underneath a pointer placed above or at one side of the flywheel just when the valve indicated by the marking is opening or closing. In case there is no pointer the line should be brought to the topmost point on the wheel.

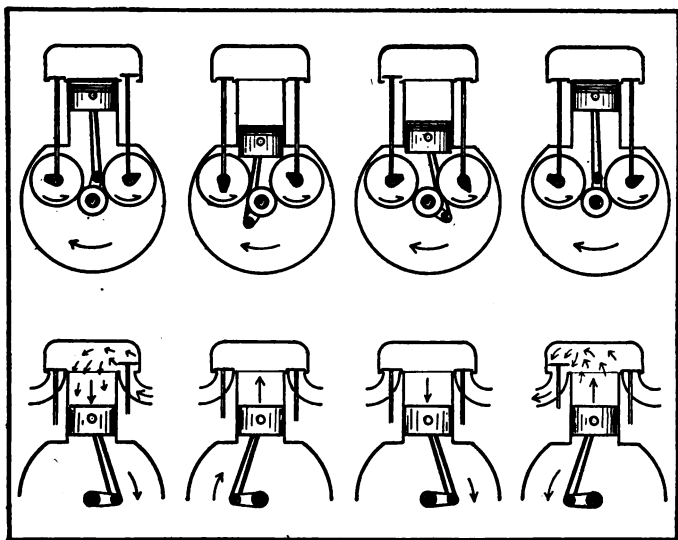

FOUR CYCLE ACTION.

Top row, left to right—Exhaust valve (at left) just closed and inlet ready to open. Inlet just closed, piston going up. Exhaust ready to open near end of firing stroke. End of exhaust stroke.

Bottom row, left to right—Piston going down on the inlet stroke, up on the compression stroke, down on the power stroke, and up on the exhaust stroke.

The markings are made as follows:

I O means inlet valve opens.

I C means inlet valve closes.

E O means exhaust valve opens.

E C means exhaust valve closes.

T C means piston is at top center or the top of its stroke.

B C means piston is at bottom center or bottom of its stroke.

Written under these letters or close after them will be the numbers of the cylinders whose valves may be placed in these positions. In a four-cylinder engine these numbers will be 1 and 4 or else they will be 2 and 3 for the reason that cylinders 1 and 4 are moving together and 2 and 3 are moving together.

The reason that there are two numbers in place of only one for the valve positions, is that the flywheel makes two complete turns for each cycle of operations (inlet, compression, power and exhaust).

It will thus be seen that should either the inlet or exhaust valve be just ready to open or close on a certain cylinder when the flywheel mark is under the pointer, turning the flywheel once will not make the same valve on the same cylinder ready to do the same thing for the reason that it takes two complete revolutions to bring this valve ready to perform the same operation again.

However, one revolution will bring a corresponding valve (inlet or exhaust) into position to do the same thing as the first valve mentioned, but this valve will be on another cylinder, whichever cylinder is moving the same way as the first cylinder considered.

If the engine has only one camshaft it will be sufficient to time only one valve on the engine, all the rest being timed automatically at the same time.

If the engine has two camshafts it will be necessary to time one exhaust valve and one inlet valve.

If the flywheel has markings for valve opening and

closing positions turn the flywheel until any marking selected (which one does not matter) is under the pointer or at the topmost point of the flywheel rim.

Next, turn the camshaft in the same way that it runs until the valve indicated by the flywheel markings (inlet or exhaust) is just ready to open or close as directed by the markings and on either cylinder indicated by the numbers on the flywheel.

Now mesh the gear on the camshaft with the small gear on the crankshaft, or mesh these gears with the idler gear found between the two while the flywheel and camshaft are in the positions given.

If there are no markings on the flywheel the easiest way to set the valves very nearly correct is as follows:

First, open the petcock on top of the cylinder or remove the valve cap or spark plug so that you can feel or see the piston when it comes to the top of the stroke. Sometimes the flywheel will have T C marked, meaning that when this mark is under the pointer or uppermost on the flywheel the cylinder indicated by the number has its piston at top center or the upper end of the stroke. If these marks are on the wheel it will not be necessary to see or feel the top of the piston.

Next, bring number one piston to the top of its stroke and then turn the flywheel about one-half inch in the same way that it rotates.

Now turn the camshaft in the same direction it runs until the exhaust valve of number one cylinder is just ready to close.

Then mesh the timing gear on the camshaft with the one on the crankshaft or the intermediate gear while the camshaft and piston are in the positions given.

If there are two camshafts, set the exhaust valves as given above, then set the inlet valve so that it opens just as soon after the exhaust valve closes as you can set it, but do not let the exhaust and inlet valves be open at the same time.

The inlet valve usually opens immediately after the exhaust valve closes, this point being anywhere from top center to fifteen degrees after top center on the inlet stroke with the piston going down. The inlet valve closes anywhere from fifteen to thirty degrees after bottom center with the piston coming up on the compression stroke.

The exhaust valve opens from thirty to sixty degrees before bottom center with the piston going down on the power stroke and closes from two to fifteen degrees after top center when the piston has started down on the inlet stroke.

On account of wear in the valve operating parts and cams it is not always possible to time the opening and closing of the valves as seems best. If this is the case it must be seen that the exhaust valve closes at the right time, this being the most important thing to look out for. You can then bring the other points of opening and closing as near right as possible by adjusting the length of the push rods, although this method may cause noisy operation or possibly insufficient valve opening.

Push rods should be adjusted so that there is just room for a piece of wrapping paper to pass between the lower end of the valve stem and the top of the push rod. The less space left at this point the quieter will be the operation.

Lengthening the push rod or valve stem opens the valve earlier and closes it later. Shortening the push

rod or valve stem opens the valve later and closes it earlier.

Lengthening the stem or rod holds the valve open longer and shortening them makes the time of opening shorter.

If the engine is small and runs at high speed, adjust the valves as follows:

Inlet opens later— 12° to 15° after top center.

Inlet closes later— 25° to 30° after bottom center.

Exhaust closes later— 10° to 12° after top center.

If the engine is large or runs slow, adjust as follows:

Inlet opens earlier— 5° to 10° after top center.

Inlet closes earlier— 15° to 20° after bottom center.

Exhaust opens later— 30° to 40° before bottom center.

Exhaust closes earlier— 0° to 5° after top center.

Medium speed engines should have adjustments midway between the above.

Nothing but actual trial will show the best valve setting for any engine.

Timing, Sleeve Valves. Sleeve-valve engines, the best known being the Knight engine, operate on the ordinary four-cycle principle as far as the time of opening and closing of the valves is concerned.

The cylinder is water jacketed on the outside and sliding inside the cylinder is the outer sleeve. Inside this sleeve is the inner sleeve and inside of the inner sleeve is an ordinary piston.

There is an inlet hole or port through one side of the cylinder which communicates with the carburetor and an exhaust hole or port in the opposite side which opens into the exhaust manifold.

The upper ends of the sleeves slide up into a circular cavity or groove in the head of the cylinder. This cavity has a cast iron ring in its walls much like a piston ring, which prevents leakage of gas between the sleeves and cylinder walls. This ring is called a "junk" ring.

Pinned to the lower edge of the sleeves are short connecting rods which operate from eccentrics on a shaft corresponding to the cam shaft in a poppet valve engine. One of these connecting rods is longer than the other. The long rod is fastened to the outer sleeve and the short rod operates the inner sleeve.

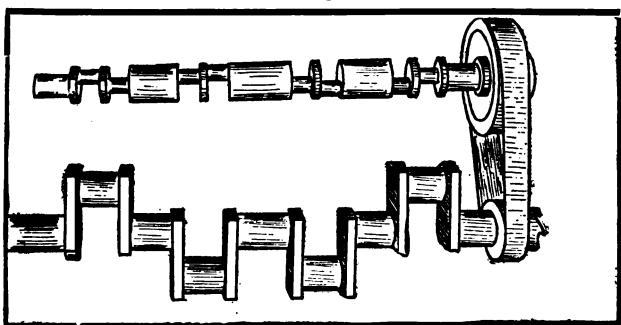

CRANK SHAFT AND ECCENTRIC SHAFT OF SLEEVE
VALVE ENGINE

Figuring in the way that the eccentric shaft turns, the short connecting rod operating the inner sleeve is set about sixty degrees ahead of the position of the long connecting rod operating the outer sleeve.

This makes the inner sleeve start down before the outer one has reached the top of its travel and the inner sleeve gets to the bottom of its movement and starts up again before the outer sleeve reaches the bottom of

its travel. The outer sleeve is always following but never catches up to the inner sleeve.

The eccentric shaft turns at the same speed that the ordinary cam shaft turns, that is, at one-half the speed

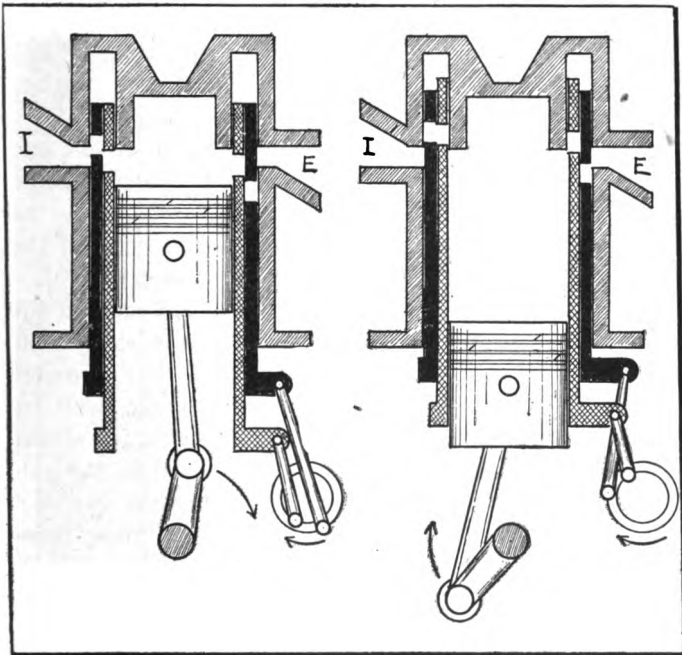

SLEEVE VALVE ENGINE.

Beginning of inlet stroke at left, beginning of compression stroke at right.

of the crank shaft. The eccentric shaft turns in the same direction that the crank shaft turns and is usually connected to the crank shaft by a silent chain.

When the piston is within about fifty degrees of the bottom of the power stroke the exhaust port in the outer

sleeve is opposite the exhaust hole in the cylinder wall and the sleeve is moving up. At the same time the inner sleeve is coming down and just as the port in this inner sleeve comes out of the cavity in the top of the cylinder wall it is opposite the port in the outer sleeve and since the port in the outer sleeve is opposite the hole in the cylinder the burned gas escapes into the exhaust manifold. The outer sleeve has reached the top of its stroke and is moving downward slowly.

The piston now starts up on the exhaust stroke and when it is about half way up the outer sleeve is moving down quite fast so that its opening passes below the edge of the hole in the cylinder wall and cuts off the escape of gas just as the piston passes top center.

When the outer sleeve moved down and cut off the exhaust it brought the hole in the opposite side of the sleeve opposite the hole in the cylinder that connects with the carburetor and as the inner sleeve went up at the same time, the inlet port of the inner sleeve comes opposite the port in the outer sleeve and the hole in the cylinder just after the exhaust opening was shut off and just as the piston starts down. These three ports now stay more or less opposite each other while the piston goes down, until, after the piston again starts up, the inner sleeve comes up and by passing above the edge of the hole in the cylinder and in the outer sleeve the inlet gas is cut off just after the piston starts up on the compression stroke.

Both holes in the cylinder are now kept closed by the movement of the sleeves during the balance of the compression and the first part of the power strokes.

To set or time the sleeves :

Take the spark plug out of number one cylinder and

stick a stiff wire or rod down through the opening until it touches the top of the piston.

Turn the engine slowly by hand until the piston comes to the top of its stroke.

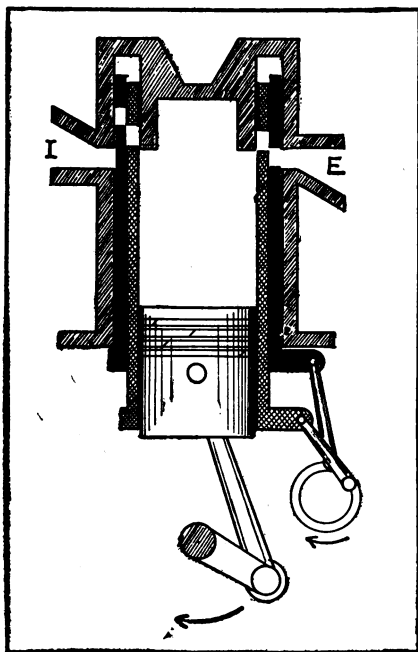

SLEEVE VALVE ENGINE.

Exhaust port opening near end of power stroke.

With the piston in this position start and move the flywheel in the same direction it runs for about one-half or three-fourths of an inch.

Leave the piston in this last position and turn the eccentric shaft in the same direction it runs until the

inner sleeve and short connecting rod are at the bottommost point of their travel.

The outer sleeve and long connecting rod should now be well down on their stroke.

Mesh the gears or place the chain on its sprockets with the piston and sleeves in these positions.

Timing, Rotary, etc. In any engine operating on the four-cycle principle the exhaust valve must close immediately after the piston has passed top center and

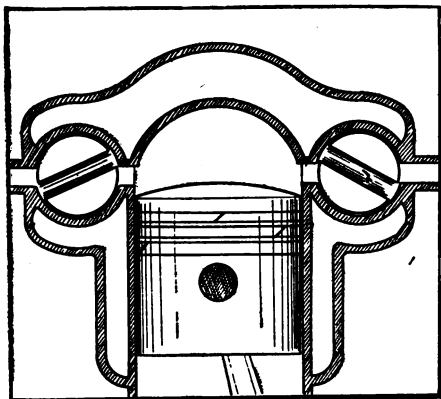

ROTARY VALVE ENGINE.

is ready to come down, from 2 to 10 degrees after top center being about right. •

The inlet valve must open just as soon after the exhaust closes as is possible without having both valves open at the same time.

Therefore, it is only necessary to bring the piston and the valves or ports into such positions that they comply with these conditions and then mesh the gears or attach the chains. This will properly time any valve.

VULCANIZING.

Vulcanizing is the process of heating raw rubber gum to a point at which it changes its characteristics, becoming tough and elastic and capable of resisting wear. This process is used by applying heat generated from burning gasoline, electric heating coils or a steam boiler to the raw rubber after the rubber is placed on the tire to be repaired. The construction of various vulcanizers differs materially in details and arrangements of parts. All types, however, have plates against which the tire is held with moderate pressure while the rubber is being vulcanized. In electric and steam vulcanizers there will be means for regulating the degree of heat.

Temperature. The higher the temperature the less time is required, but the work will not be so good as with lower temperature and more time.

Length of Time. Good vulcanizing depends on:

1. Allowing the cement to dry a **long time**.
2. **Not touching** the cemented surfaces with fingers.
3. **Taking your time** and following directions.

Terms Defined. **Semi-cured patching stock** is rubber that is left raw on one side and is vulcanized on the other. It is used for inside patches with the vulcanized side **inside** and the unvulcanized side facing the hole.

Raw gum is unvulcanized rubber. It comes in various thicknesses and is used for filling up holes and cuts. It must be cleaned before using.

Heat and Time. For ordinary work use the following combinations:

Heat at 250°	20	minutes
“ “ 255°	19	“
“ “ 260°	17	“
“ “ 265°	15	“
“ “ 270°	13	“
“ “ 275°	12	“
“ “ 280°	10	“
“ “ 285°	9	“

Remarks. Before applying the heating iron to the work cover the tube and patch with a piece of linen—**never** with paper.

After removing the iron sprinkle chalk on the patch and rub with a cloth.

Test each tire after vulcanizing by pumping up and placing in water.

After testing let the tire dry. Then remove the valve core and let all the air out. Replace the core and tie the tire loosely.

To Prepare Small Holes in Tubes—

1st. Locate the leak. If it is a pinhole and there is no rubber gone from the tube, take a piece of unvulcanized gum one-half inch in diameter and apply a thin coat of cement to one side and lay it aside to dry.

2d. Clean the tube around the hole with gasoline and a cloth, or with a brush if necessary to cut down to the rubber.

3d. Apply a thin coat of cement to the tube around the hole, covering a space as large as the patch.

4th. After allowing the cement to dry for **ten minutes (no less)** place the patch on the tube with the

two cemented surfaces together and apply the heating iron.

5th. **Heat.** Apply the heat for 10 to 15 minutes at temperatures between 250° and 275° with moderate pressure.

To Prepare Large Holes In Tubes—

1st. If the hole is large, or if some of the rubber is gone, you should cut away the rough edges, making the hole still larger and of a fairly regular shape.

2d. Cut a piece of **semi-cured patching stock** the same shape as the hole and about one-fourth inch larger all around.

3d. Clean the raw side of this piece and apply a thin coat of cement and lay aside to dry.

4th. Wrap a piece of cloth around your forefinger and dip it into gasoline. While the cloth is wet clean the **inside** of the tube all around the hole until no more chalk comes off on the cloth.

5th. Dip the brush in the cement and apply a thin coat of cement all around the hole **on the inside of the tube** by pushing the brush in through the opening.

6th. Let the cement dry at least **ten minutes**, or better still **fifteen minutes**.

7th. Mark the center of the patch on the raw or cemented side with a soft pencil and stick it through the hole so that the raw side, which has the cement on it, will face the hole.

8th. Press the tube down onto the patch so that the patch extends evenly all around the edges of the hole.

9th. Apply a thin coat of cement to the edges of the hole and let it dry **ten minutes**.

10th. Cut a piece of **unvulcanized gum** the exact size of the hole and fit it into the place so that the hole is filled with the rubber right out to the edges but not overlapping the edge. Be sure that the hole is **even full** of rubber.

Heat. Apply the heating iron at 250° to 280° for 12 to 20 minutes.

WHEELS.

D. Automobile wheels are made either with wood or wire spokes. Wood wheels have been used since automobiles were introduced in their modern form but the very earliest cars were equipped with wire wheels. Wire wheels are now in favor again.

A. Wire wheels may be straightened by tightening or loosening the small nuts that hold one end of the spoke to the rim or hub in practically the same way as bicycle wheels are straightened.

If the wheels are out of line they may be set as directed under Steering Gear.

R. Wheels are removed and replaced as directed under Axles, reference being made to the various types of axles in use.

Wood wheels may be removed from their hubs by taking out the bolts that pass through the flanges of the hubs and the inner ends of the wheel spokes. The outer flange may then be pulled off and the other flange with the hub driven out by resting the spokes on some solid place with an opening through it large enough for the hub to drop through. The rim is placed around the wood felloe of the wheel while red hot and then quickly cooled, shrinking it in place. To remove the rim in the ordinary shop amounts to destroying the wheel for further use.

T. Should a wood wheel become bent or dished from use or accident it must be taken to a wood working or wheel shop where the spokes can be properly reset and tightened in the felloe and hub.

Should the rim or spoke become loose in the part it fits into the result will be a more or less loud squeak each time the wheel turns around. This squeak may be easily heard by some one standing beside it, when the car is slowly run past, or it may be heard by leaning out over the suspected wheel while the car is running.

When the spokes become loose in the felloe the remedy is to take the wheel to a woodworking shop for re-setting or new spokes.

If the inner ends of the spokes do not fit properly around the metal of the hub the hub flanges may possibly be drawn tighter together. If the end of the spoke stays away from the hub this space may be filled up by pouring it full of melted lead or melted sulphur.

While these methods may give satisfaction, their value is doubtful. The proper remedy is new spokes or a new wheel.

WRIST PINS.

D. The wrist pin passes through the piston from side to side. Inside the piston the upper end of the connecting rod has a bearing on the wrist pin so that the power delivered to the piston by the burning gas is transmitted to the connecting rod through the wrist pin.

Wrist pins are made from steel with the surface hardened.

The wrist pin may be fastened tightly into the piston walls and in this case the upper end of the connecting rod has a bearing and a slight turning motion or rocking motion on the wrist pin.

In other engines the upper end of the connecting rod fastens or clamps tightly around the wrist pin and the pin then turns in and has a bearing in the piston wall. This is the more modern practice. The hole in the piston wall is then provided with a brass or bronze bushing or bearing, or the bearing may simply be the hole bored in the wall of the piston.

As a rule, wrist pin bearings are made in one piece, but in some engines having the connecting rod turn on the wrist pin the bushing in the upper end of the connecting rod may be split along one side. The upper end of the connecting rod is then formed into a clamp.

A. There should be a sidewise play or movement of the connecting rod along the length of the wrist

pin or else the wrist pin should have a slight endwise play in its bearings.

If, however, the bearings have up and down play or looseness noticeable when pulling and pushing on the connecting rod this looseness must be removed.

If the upper end of the connecting rod is a clamp, remove some of the washers or shims between the edges of the clamp and draw the bolt tighter than it originally was.

Looseness in a solid bushing makes it necessary to replace it with a new bushing. Before doing this remove the wrist pin and test it for perfect roundness at several points with the micrometer calipers.

If the wrist pin is not perfectly round a new one must be secured or else the old one must be made round by grinding on a grinder. After a wrist pin has been ground a bushing must be specially made and fitted with freedom of movement but without play.

Should there be no bushing in the piston walls, the pin have its bearing in the piston wall itself, the play can be remedied only by new pistons and possibly new pins, or you may test and make the pin perfectly round, bore the hole in the piston wall larger and insert a special bushing made for the job.

T. Should a wrist pin have movement enough lengthwise of the holes in the piston so that it can work out and touch the cylinder walls it will cut deep grooves in the walls, making it necessary to handle the job as given under Cylinders.

R. There is always some way of locking or fastening the wrist pin so that it cannot work out and touch

the cylinder wall. This may be done with clamps, set screws, straight or taper pins, plugs screwed in the ends of the pin, by an extra piston ring passing around outside the wrist pin ends or in some other noticeable way. When reassembling an engine be sure that the pin is securely locked in place.

WORKING OF THE FOUR CYCLE ENGINE.

Stroke and Revolution. When the piston moves from one end of the cylinder to the other end as far as it can travel it has made one "stroke," that is, from the closed end or head of the cylinder to the open end is one stroke and from the open end back to the closed end is another stroke.

The crank shaft and the fly wheel make one complete turn or one "revolution" to two strokes of the piston. The piston makes one out stroke and one in stroke while the fly wheel turns around once.

The Inlet Stroke. When we wish to start the engine the first thing to do is to fill the combustion space with fresh gas and the more fresh gas we can get into this space the more power we will get from the engine.

The crank shaft must be turned until it moves the piston as near to the cylinder head as it will go, then, the inlet valve must open. Now, by turning the crank shaft more the piston will be drawn to the outer end of the cylinder.

The hole that was opened by the inlet valve connects with a pipe that leads to the carburetor (where the gasoline is mixed with air so that the mixture will burn) and as the piston moves toward the open end of the cylinder it will draw the cylinder full of fresh gas.

The stroke that fills the cylinder with fresh gas is called the "inlet stroke" or the "suction stroke."

The Compression Stroke. At the end of the inlet

stroke, when we have drawn all the gas into the cylinder that it will hold the inlet valve closes. At this time the exhaust valve will also be closed tight. We must keep on turning the crank shaft and drive the piston back toward the cylinder head.

Since both valves were closed the cylinder full of fresh gas is now packed or compressed into the combustion space. When the gas is compressed it becomes very explosive and burns with great pressure.

When the piston is as near the cylinder head as it will come we will set fire to the gas. The place that the piston is at in the cylinder when we set fire to the gas is the "firing point" and the stroke that compressed the gas is the "compression stroke."

The Power Stroke. The gas now burns so fast that it is like an explosion and the high pressure drives the piston back toward the open end of the cylinder. The piston pushes on the connecting rod, the connecting rod turns the crank shaft and the crank shaft turns the fly wheel. This stroke of the engine is the "power stroke" or "explosion stroke."

The Exhaust Stroke. At the end of the power stroke, when the piston has moved as far as the crank and connecting rod will let it go we can get no more work out of that stroke and the next thing to do is to get rid of the burned gas so that we can get more fresh gas into the cylinder.

In order to get rid of the burned gas the exhaust valve opens and as the piston goes back into the cylinder it pushes the old gas ahead of it and out of the cylinder.

This stroke of the engine is called the "exhaust

stroke" and it ends when the piston is as near the cylinder head as it can get. The piston is then in a position to start another inlet stroke and the engine goes through the same work as before as long as it continues to run.

The Four Cycle Engine. There is only one power stroke out of the four strokes of the piston, that is, the crank shaft and the fly wheel turn twice around, for one power stroke. The first full turn of the crank shaft makes the piston go out on the inlet stroke and back on the compression stroke. The next full turn of the crank shaft lets the piston go out on the power stroke and back on the exhaust stroke.

There are four strokes of the engine, the inlet, the compression, the power and the exhaust and then these strokes are repeated over and over again as long as the engine runs.

Any series of events that happens in a regular order and then repeats in the same order is called a "cycle." The four strokes of the engine form a cycle and this type of engine is called a "four cycle engine."

SUMMARY OF THE FOUR STROKES.

Revolution	Stroke		What is happening	Position of valves
	Number	Name		
First	{ 1st	Inlet	Sucks gas in	Inlet valve open
	{ 2nd	Compression	Compresses gas	Both valves closed
Second	{ 3rd	Power	Turns crank shaft	Both valves closed
	{ 4th	Exhaust	Pushes old gas out	Exhaust valve open

SECTION TWO

**How to Use, Buy or Make Materials and
Supplies Used in Running a Car.**

**Subjects in This Section Are Arranged Alphabetically Under
the Name of the Material.**

MATERIALS AND SUPPLIES

Acetylene Gas Tanks. Acetylene gas for lighting the lamps of the car is carried in steel cylinders made and filled in factories. These tanks are made in various sizes, holding from 10 to 70 cubic feet of the gas.

The Prest-O-Lite tanks are designated by letters according to their size. Size A holds 70 cubic feet, size B (the one most used) holds 40 cubic feet, size E (often used on small cars) holds 30 cubic feet and size MC (motorcycle) holds 10 cubic feet.

The Searchlight tank corresponds in size to the size B.

One of these tanks, when emptied of its gas, may be exchanged for a full one by paying for the gas, from two and one-half to six and one-quarter cents per cubic foot of gas, depending on the locality where purchased.

As a general rule the owner throws away from one-fourth to one-half the total amount of gas he buys because of leaking hose connections at the lamps, leaky or broken joints in the copper or brass piping on the car and from not screwing the union tight at the tank. See Carbide.

Alcohol. Alcohol is made by distilling various kinds of plants and woods, it being possible to produce alcohol in any part of the country and from almost any vegetable matter at hand. As a fuel it has advantages and disadvantages.

One of these tanks, when emptied of its gas, may be exchanged for a full one by paying for the gas, from two and one-half to six and one-quarter cents per cubic foot of gas, depending on the locality where purchased.

As a general rule the owner throws away from one-fourth to one-half the total amount of gas he buys because of leaking hose connections at the lamps, leaky or broken joints in the copper or brass piping on the car and from not screwing the union tight at the tank. See Carbide.

Alcohol. Alcohol is made by distilling various kinds of plants and woods, it being possible to produce alcohol in any part of the country and from almost any vegetable matter at hand. As a fuel it has advantages and disadvantages.

Alcohol is slightly heavier than gasoline, having a specific gravity of about .820. Its fuel value (heat units) per gallon is only about 57 per cent of that of gasoline so that it would take at least a gallon and a half of alcohol to drive the car as far as a gallon of gasoline would drive it. For this reason, alcohol would have to sell for much less than gasoline to compete with it.

When a carburetor is used for alcohol the flow through the nozzle must be almost once and a half the flow of gasoline under the same conditions. It is no more necessary to heat alcohol than it is to heat gasoline but the compression in the engine should be twice as great as with gasoline, from 130 to 190 pounds per square inch.

Any engine might be used with alcohol by applying means for heating the incoming air, the same as would be done for gasoline, fastening enough cast iron plates to the top of the piston to raise the compression to at least 150 pounds and fitting a larger carburetor or nozzle or opening the needle valve more.

Alcohol is cleaner when burned and has less odor than gasoline.

Grain or ethyl alcohol is the kind found in intoxicating liquors.

Wood or methyl alcohol is made from wood and is very poisonous.

Denatured alcohol is grain alcohol with some wood alcohol or other substance added to make it unfit for drinking purposes.

Anti-Freeze Mixtures. See under Cooling Systems.

Benzol Fuel. Is used in England and Europe in place of gasoline to a large extent. It is not produced or used in this country to amount to anything. It is made while producing coke. Benzol, like kerosene, develops more power from a gallon than gasoline.

Carbide. (Calcium Carbide) Is used for making acetylene gas for burning in the lamps of the car. The carbide, purchased in small lumps, is placed in a gas generator so that a small stream of water can run onto the carbide when gas is wanted. The water and carbide form acetylene gas which is led to the lamp burner through suitable tubing and connections.

The carbide is held in a wire bottomed basket and the used part or ash should drop through into another chamber below the basket. If this lower compart-

ment becomes filled with the ash the generator can no longer act. The whole interior of the generator must be kept clean and the small pipe and valve that allow the water to come from the upper tank to the wire basket must be kept open so that the water may have a free flow when the valve is turned on.

The gas pipes leading to the lamps must be kept perfectly tight or most of the gas will be lost and the lamps will not burn properly. To test these pipe lines remove the end from the generator or tank and have an assistant hold the two lamp lines closed by squeezing the hose connections tight or by taking them off the lamps and holding the ends closed. If you can force air into the generator end there is a leak that should be repaired at once.

The lamp burners themselves are made with two very small holes for the gas to come out of. These holes are set in arms of the burner so that the stream or jet of gas coming from one strikes the jet coming from the other and spreads the flame into a broad white light.

Should one of these small holes become clogged the flame from the other one will be so long that it will almost always strike the mirror in the back of the lamp or the glass in front of the burner. It will crack either one of them and as the glass is worth about thirty cents and the mirror from one to four dollars this should be avoided. The holes should be kept clean with a very small wire, not much larger than a bristle. These may be bought from supply stores as Burner Cleaners.

The burner should be screwed snugly onto its

threaded pipe so that there will be no gas leak around the threads. The burner should be turned until the broad, flat part of the flames faces forward, not with the edge of the flame pointing forward.

Castor Oil for Lubricating. Castor oil has been used a great deal in racing cars for two reasons. It is not dissolved by gasoline and it retains its body and lubricating qualities at a heat far above that at which petroleum mineral oils burn up or become extremely thin and of little lubricating value. These qualities apply only to absolutely pure unadulterated castor oil. If the oil has been mixed with other vegetable oils these properties disappear and the oil becomes dangerous to use under any conditions. Castor oil's great disadvantage is its very disagreeable odor from the exhaust.

Castor oil is not suited for use in circulating systems as it loses some of its good properties and becomes thick and gummy in constant use, forming a thick deposit of coke or carbon on the inside of the combustion chamber. Pure fresh castor oil lubricates even better at a high temperature than at comparative low heat.

The purity of castor oil may be tested by placing one part of the oil in a clean glass and adding five times as much grain alcohol (90% alcohol) with both parts of the mixture at a temperature of 60 to 65 degrees Fahrenheit. If there is any impurity in the castor oil the mixture will be cloudy, if the oil is pure the mixture will be clear.

Chalk (Talc or Soapstone). Is used by sprinkling it inside the outer tire or casing and onto the inner

tube so that the two will not stick together, the tube being easily removed after long periods of running. It is also used by sprinkling it on the leather facing of clutches (cone or plate) to prevent slipping, or between the parts of the clutch should they become oily or greasy. A very little chalk sprinkled on the leather of the clutch makes it take hold and work properly, too much makes it grab and jerk. Chalk, talc or soapstone is usually sold in one pound cans costing ten or fifteen cents or it may be bought in bulk for three cents and up per pound, depending on the grade and quantity.

Cork, Ground. Is used by mixing it with the grease or oil in the sliding gear transmission case or in the rear axle to make old and worn out gearing run more quietly. Only a small quantity, about a cupful, should be used at first as a trial and more may be added to produce the desired result. If the lubricant is made too thick so that it may cake between the gear teeth there is great danger of bursting the case. Ground cork may be bought from supply houses for about fifty cents per pound. It may also be obtained at fruit stands, although this kind is not ground fine enough to do the best work.

Sawdust, called wood fibre, is also used for this purpose but it cakes and gums much easier than cork and is more dangerous to use.

Gasoline. Gasoline is secured by distilling crude petroleum, the gasoline forming from one-thirtieth to one-fifth of the total quantity of crude oil. During this same distillation there is secured naphtha, benzine, kerosene, lubricating oils, asphalt, etc.

The crude oils come from Pennsylvania, Texas and

California. Pennsylvania oil contains from one-eighth to one-fifth of its volume in gasoline, Texas and California oils containing only about one-thirtieth.

In using gasoline the liquid must first be turned to a vapor, then mixed with about five parts of air. When this mixture is compressed to a pressure of seventy pounds per square inch and exploded it delivers about 375 pounds per square inch pressure to the top of the piston and causes a heat of over 3,000 degrees.

Gasoline has a specific gravity of about .720 in the grades ordinary sold, this corresponding to sixty-five degrees Baume scale. Gasoline is graded according to the Baume scale, the higher the number of degrees Baume the lighter the gasoline is and the better fuel as far as easy burning and quick evaporation go.

Good gasoline should have a Baume test of sixty-eight degrees, high test gasoline tests seventy-two degrees and extra high test shows seventy-six degrees. The higher the Baume test the easier the engine is to start and the smoother it runs, but the gasoline costs more in the higher grades. When the Baume test is below sixty degrees the liquid is called naphtha, not gasoline.

The evaporation of gasoline into vapor in a carburetor lowers the heat fifty degrees Fahrenheit, this being the reason for heating the incoming air or the manifold or the mixing chamber in modern carburetors.

The specific gravity or Baume test of any gasoline may be found by the use of a gasoline hydrometer which may be bought of any supply house. These hydrometers are floated in the gasoline and the degrees Baume shows on the scale at the level of the liquid on the hydrometer scale.

For use in the gasoline engine this fuel should be practically free from water. The water may be strained from the gasoline by fitting a chamois skin over the funnel and pouring the gasoline through the chamois. Most of the water will remain in the chamois skin together with any dirt that may have been in the liquid.

After gasoline is used for cleaning parts the metal should be wiped with a clean oily cloth to prevent rust unless the part is immediately replaced in the car where it will become covered with grease or oil.

To prevent leakage of gasoline past the screw threads of joints make a thick paste of litharge mixed with glycerine and cover the threads before screwing together. This paste is not affected by the gasoline. Any preparation of lead and oil will be washed away as soon as the gasoline comes in contact with it.

Glycerine. Is used mixed with the cooling water or mixed with water and alcohol to prevent the water from freezing in cold weather. Glycerine is sold by the pound and may be bought from supply houses or drug stores. It costs about fifty cents per pound. For the proportions to use see under Anti-Freeze Mixtures.

Graphite. Is almost pure carbon. It acts as a very efficient lubricant and friction preventative when applied to any sliding parts or bearings. It may be mixed with oil or grease or applied dry as the case requires.

Graphite forms a very smooth, soft covering on the metal surfaces, becoming so smooth and bright with use that the surfaces look like mirrors.

Graphite will stand extreme heat without damage

and will remain in place on the bearing or sliding surfaces under practically all conditions.

Graphite is prepared and sold in various grades from large flakes down to a powder so fine that it does not settle in water. The flake graphite is suitable for use in gear boxes, rear axles, universals, pipe joints, etc., but not in the cylinders and crank case of an engine having a circulating or pumped oil feed.

Very finely divided graphite is sold under the name of Oildag and is used by mixing with the engine oil. This Oildag comes in small cans, these cans containing enough for one gallon, five gallons or ten gallons of oil and selling for twenty-five cents, \$1.00 and \$2.00 in most localities. This same type of graphite for mixing with grease is sold under the name of Gredag in cans suitable for mixing with five, ten or twenty-five pounds of grease. These sizes usually sell for \$1.50, \$2.75 and \$5.50 respectively.

Flake graphite is sold in cans holding from one-half to five pounds of the graphite. It costs about fifty to seventy-five cents per pound, depending on the quantity in the can.

Graphite reduces the quantity of oil or grease required, by filling up all the small rough places and making the surfaces very smooth. It also helps to prevent bearings seizing from lack of enough oil.

Grease. Should be used for lubricating where the pressure is heavy and the speed comparatively slow. The tendency in modern cars is to lessen the use of grease and use cylinder oil in its place wherever possible.

Grease comes in all qualities, good and bad; the only safe guide in buying is to secure it from a com-

pany having a good reputation and to pay a fair price. Cheap grease is usually adulterated with soap or tal- low of low grade making it unfit for use around metal parts.

Grease comes in all grades from very stiff, hard cup grease to non-fluid oil which is but little thicker than cylinder oil. Greases are also mixed with graphite, sawdust, cork and other materials to produce special results.

Cup grease is the heaviest grease ordinarily used around the car. It is stiff enough to be cut into pieces that will retain their shape. Cup grease is used in all grease cups anywhere on the car, in universal joints and steering gear cases and at any point where the thickness of the grease is depended upon to keep it from leaking. Cup grease is worth from ten to twenty cents a pound depending on the quantity purchased.

Transmission greases are thinner and lighter in body than the cup greases. They come in several grades; light, medium and heavy; being thin, rather thick and almost as thick as cup grease respectively. Transmission greases are used in transmission gear cases having annular or roller bearings, in timing gear cases where this case is tightly partitioned off from the crank case, in all other bearings that are arranged grease tight, such as the wheels, in the differential case of the rear axle and on sliding parts except in the engine.

The thinner the grease used the better the lubrication and the easier the work on the mechanism, but do not use grease so thin that it will work out of the bearings to the outside of the case.

Transmission grease costs about one-fifth more than cup grease.

Non-fluid oils are high grade greases made from mineral oil exclusively. They come in light, medium and heavy grades, the lightest being thin enough to pour easily. Non-fluid oils cost from twenty to thirty cents a pound.

Fibre grease is rather heavy transmission or cup grease with which has been mixed a greater or less quantity of finely ground wood or cork. See under Cork.

Graphite grease is composed of any grade of grease with which is mixed flake or powdered graphite. The same grade of graphite grease is used as if the grease had no graphite. See Graphite.

Kerosene. Is used for fuel in some forms of carburetors and engines. In this case, as with alcohol, the engine is started with gasoline and after becoming warm the gasoline is shut off and the kerosene turned on by a three way valve within reach of the driver.

Kerosene gives more power per gallon than gasoline and is also much cheaper. The engine or carburetor must be specially fitted for its use because kerosene will not turn to vapor below a heat of 200 degrees Fahrenheit. In burning kerosene it is usual to add a little water or steam to the mixture, this giving smoother operation and preventing the formation of carbon deposits so quickly.

Kerosene has a specific gravity of about .790 and a Baume test of forty-six to fifty degrees. It is not necessary to change the compression pressure of a gasoline engine as must be done for alcohol. In fact kerosene may be used with a slightly lower compression than gasoline. Kerosene vapor or mixture does not give such a strong push when the piston starts

down but keeps a steadier pressure throughout the whole stroke, the average push during the whole stroke being greater than with gasoline.

Kerosene is used in the shop for cleaning parts and it is very effective in loosening tight bolts and nuts and any parts that have become seized, such as stuck pistons and bearings. It is only necessary to allow the kerosene to remain in contact with the joint or bearing for several hours when it will work its way through and the parts may then be forced apart.

A teacupful of kerosene placed in each cylinder of the engine at night (while the engine is still hot) and allowed to remain until morning keeps the engine running smoothly and prevents the formation of carbon and scale to a great extent. This may cause hard starting if placed in all cylinders.

Contrary to the belief of many, kerosene is not suitable for use in the cooling system, being difficult to circulate and making the fire risk much greater. In addition to this it attacks and ruins the rubber connections in time.

Machine Oil. Is a very light bodied and light colored oil which is used for lubricating the bearings of magnetos, breakers and timers and electrical machinery in general. It is much more suitable for this work than cylinder oil.

Mica Flake. Is used in place of chalk or soapstone in the casings and tubes to prevent their sticking together. Mica is also used like graphite, for mixing with grease, as it resists heat. Under some conditions mica is to be preferred to graphite, especially around some forms of electrical machinery as it is a very good insulator, while graphite is a very good conductor.

Neatsfoot Oil. Is used for preserving the leather facings in clutches in good condition. It is also used to prevent and cure clutches from grabbing or taking hold with a jerk. In refacing a clutch the leather is soaked in the oil as directed under Clutch, Cone, but in curing grabbing it can be applied by pouring it onto a thin piece of cardboard and then slipping the cardboard between the leather and metal surfaces while the clutch is held released. Neatsfoot oil may be purchased from supply stores or from harness shops.

Oils, Lubricating. Cylinder oil or engine oil is used in all parts of the engine and in many cars in the transmission and rear axle as well. If the engine, clutch and transmission are in one unit or one case, cylinder oil will be used throughout the set. If the clutch and transmission are in one case and communicate with each other cylinder oil will be used in both. Any form of clutch running in oil requires nothing but oil. The greatest care must be used when other parts have oil passages communicating with the crank case that nothing but cylinder oil is used in these parts. It is not always apparent without careful examination and test, that the transmission case opens into the clutch and crank cases with the result that grease might be placed in the transmission and find its way into the engine, ruining the bearings and cylinder walls.

Nothing but the best grades of cylinder oil should be considered, cheap and unknown oils usually proving to be a costly experiment. Oil should be purchased from a reputable company, the cost in barrel lots being not less than twenty-four or twenty-six cents

a gallon under any conditions. Tests are difficult to make under ordinary conditions, the best test being in the engine itself. This test requires at least 500 miles' use of the oil, at the end of which time great damage may have been done if the oil was of poor grade.

Oil is supposed to form a thin film between the moving parts so that they will not come into actual contact but will roll on the particles of the oil. For use in the automobile engine only mineral oils secured from crude petroleum are suitable. In racing cars vegetable oils are sometimes used but this has nothing to do with ordinary practice. See Castor Oil.

Engine oil should stand the following tests:

It should remain fluid when placed in crushed ice mixed with salt, the oil being placed in a glass bottle or tube and placed so it is surrounded by the freezing mixture.

It should have a proper flash point. This is determined by having a thermometer reading up to 600 or 700 degrees placed in the oil to be tested and the oil then gradually heated over a covered flame or stove. When the oil gets hot light a candle or match and hold the flame near the surface of the oil where the vapor can reach the flame. Watch the thermometer and when the vapor from the hot oil takes fire from the flame in small puffs and then goes out again you have reached the flash point of the oil as shown by the thermometer reading. This should not be less than 475 degrees Fahrenheit. While an oil must have a fairly high flash point, often running up to 650 degrees, the higher the flash point the more carbon or soot the oil will deposit in the combustion space.

The oil should also have a proper fire point, this being found by continuing to heat the oil above the flash point until the oil takes fire and burns steadily. The temperature shown on the thermometer when this happens being the fire point. This temperature should not be less than 600 degrees Fahrenheit.

The oil should be thin enough to flow rapidly through a one-fourth inch copper tube held at a slight slant if intended for use in water cooled engines in good condition. This grade would be called light oil.

When the oil is rubbed between two smooth, flat metal surfaces under heavy pressure it should remain on both surfaces after they are separated.

Litmus paper should be bought from a drug house and a piece of red and another piece of blue paper dipped in the oil. Neither color should change. This shows that the oil contains neither acids or alkalis. The oil may be tested for acid by soaking a piece of cord in the oil and wrapping it around a clean bright steel shaft. This should dry in the sun without discoloring or marking the surface of the steel in any way.

When the oil is completely burned it should only leave a trace of ash or carbon.

There are many grades of oil having various flash and fire points, cold tests, viscosities and specific gravities. The grades are usually called simply light, medium and heavy and are bought and sold under these names. They all cost the same, the thickness having nothing to do with the cost. Light oil means one that is thin and that flows very easily, medium oil is thicker than this and heavy oil is so thick that it flows slowly. These names have nothing to do with

the color of the oil. The lighter the oil is in color the less free carbon it contains as a rule but a carbonless oil is an impossibility because oil is made of hydrogen and carbon.

Light oil should be used for water cooled engines that are almost new, in very good condition or that run at high speeds. Light oil should be favored in winter because it flows easier at low temperatures.

Heavy oil should be used in slow speed or worn water cooled engines, in air cooled cars and in motorcycles. Two cylinder engines usually require heavy oil. There are special grades of heavy oil called air cooled oils for use in air cooled engine.

Medium oil should be used in the average water cooled engine in good or fair shape and which runs at ordinary speeds. Medium oil should be favored in the warm weather because it does not become so thin.

Polish, Body. Many preparations are sold which are claimed to make the varnished surfaces of the car keep their good appearance or bring this new look back after it has disappeared. Body polishes are no doubt valuable on old cars that have lost their shine but its value on new cars is very doubtful. In order to keep a car looking good it must be applied regularly by placing a very little on a soft clean cloth and applying to the varnished surface by rubbing (only after the car has been washed). After applying the polish the surfaces should be rubbed again with another clean soft cloth to remove as much of the polish as possible. Body polish costs about seventy-five cents a quart.

Polish, Metal. Metal polish is applied by rubbing it briskly and forcibly on the metal work with a small piece of cheese cloth well soaked in the polish. **Shake**

the can of polish thoroughly before using and then pour out about half a cupful. This prevents settling of the polish while using, the parts that settle being most valuable in polishing. Let the polish dry thoroughly on the metal and then rub off with a piece of clean dry cheese cloth, this cloth being washed after each car is polished. Good metal polish costs about \$1.50 per gallon. It is not economical to buy smaller than one gallon cans.

Radiator Leak Compounds. Many makes of compounds are on the market which are to be placed in the water when the radiator or cooling system has leaky spots. The compound finds its way to the hole and plugs it from the inside. The trouble is that there is great danger of its plugging any other small passages it goes through. This seldom happens in practice because these compounds do not swell very much until they strike the air.

A very effective radiator compound consists of ordinary ground flax seed meal, bought for five or ten cents a pound at any drug store, and placed in the radiator. About a handful will stop a large leak permanently.

Soapstone. See chalk.

Soap, Oil. This soap is used for washing finely varnished and finished surfaces. Good oil soap is neither acid nor alkaline and therefore does no damage to any painted work. It looks like transparent grease and is of a greenish brown color. It is sold by the pound, coming in one, five, ten and twenty-five pound packages and in barrels and half barrels. In small quantities it sells for about twenty-five cents per pound.

It is used by placing a small quantity, about a cupful, in a half a pail of boiling water and letting it dissolve. This is then used on the car by dipping the sponge into the solution.

Tire Paint. Is a composition that is claimed to preserve the tire by making small cuts water proof. It is applied with a fine brush like any paint and leaves the tire with a white or gray appearance. It sells for about \$1.50 a quart.

Top Dressing. Is for use on leather or Pantasote tops. It is a form of paint and enamel and is applied with a fine brush after washing the top thoroughly. It leaves a bright lustrous finish, but one that will crack in time like any other paint. It takes about two quarts to cover a top. It sells for about \$1.00 per quart.

Vaseline. Is a very thin grease made from crude petroleum. It is free from impurities and is of a very light body, making a very efficient lubricant for all bearings where light transmission grease might be used. It is usually used in the bearings of the magneto and other electrical parts, its general use being prevented by its cost.

Vaseline is often used throughout the bearings, transmissions and rear axles of racing cars.

SECTION THREE

Electrical Principles Explained.

ELECTRICITY.

Without electricity the modern gasoline automobile would be an impossibility. Electricity is used to fire the gas in the cylinders, to start the engine, to light the lamps and in some cars to shift the gears, operate the horn, furnish foot and hand warmers, cigar lighters and all manner of necessities and conveniences.

No one has ever been able to find exactly what electricity is; we can only tell about its action and the effects it will produce. As a general rule we may say that electricity will produce or cause either heat, light or power according to the way it is made and used.

Kinds. Although all electricity is supposed to be the same, it seems to be in four different forms, which are called static electricity, magnetism, current electricity and radiant electricity.

Static electricity is the form that is produced by rubbing one thing on another. It is the form that is seen in a lightning flash. Static electricity is supposed to be electricity that is at rest or standing still until it comes near enough to another body to pass into that body with a discharge that may pass quietly or may take the form of a spark through the air. Static electricity is of no use in automobile work and when it does occur we take means to get rid of it, its spark doing nothing but damage if allowed to pass.

Magnetism is a form of electricity found in certain pieces of iron and steel and also in nickel and cobalt.

The forms we will deal with are used only when in iron or steel. A piece of either iron or steel which contains magnetism is said to be magnetised and is a magnet. Any magnet will attract or pull another magnet toward it or will attract another piece of iron or steel. Magnetism is supposed to be electricity that is whirling around but that stays in the magnetised body while whirling. In this way it differs from static electricity. Magnetism is used in the automobile to help make electric current and also for its action in pulling other magnets or pieces of iron or steel toward the magnet.

Current electricity is the form most valuable in our work. It is the kind of electricity that passes through wires or metal of any kind from one place to another. It is the kind that lights the lamps, fires the gas charge, starts the engine and does all the other useful things about an automobile. Current electricity is supposed to be electricity in motion in one direction and that will pass from one point to another in a more or less straight line. It does not remain in the material carrying it, only continuing to flow as long as supplied from the source where it is being produced. In this way it differs from both static and magnetic electricity.

Radiant electricity is not used in automobile work, neither does it occur in the form generally understood by this term. Radiant electricity is supposed to be vibrating, and is the kind used in wireless telegraphy. Its only occurrence in our work is called by another name, induction.

We will deal now with current electricity, magnetism and then induction as applied to automobile work.

Current Flow. Anything through which the electric current will flow is called a conductor. All metals are conductors and some other materials, such as water, are conductors although they are not as good as metals. The best conductor is silver and next to silver is copper. Copper lacks only a very small percentage of being just as good a conductor as silver, therefore copper, being so much cheaper, is the commonest conductor in use. Following silver and copper come aluminum, platinum, iron or steel and German silver in the order named, these metals all being used in the automobile.

There is no such thing as a perfect conductor; they all have more or less resistance to the flow of the electric current. This resistance to flow is determined by the material, increasing or decreasing as the material is a poor or good conductor. It is also increased when the conductor is smaller in size and the resistance is increased as the conductor becomes longer. Heat or cold may increase or decrease the resistance in certain materials.

When a material has very great resistance, so much that the current does not seem to be able to flow at all, it is called an insulator. There is no such thing as a perfect insulator but some substances are so near to being perfect that they answer all our needs. Insulators used in automobile work include porcelain, mica, glass, rubber, pitch, stone, paper, cotton, silk, shellac, etc.

Current Source. Electricity for our work is produced in two ways, chemical and mechanical. Chemical means consist of the dry cell or dry battery, me-

chanical means consist of the magneto and the dynamo or generator.

Any two materials placed in a liquid or moist bath of any kind form an electric cell and electric current will flow between the ends of the two pieces. Certain materials and baths are better than others, some of the best being used in the common dry cell. A battery is made up of two or more cells, one cell cannot be a battery although often called a battery by those who do not know the difference.

Dry cells are made from a stick of carbon surrounded by the bath of liquid. The liquid is soaked up with blotting paper and dry powders and around the outside is a shell of zinc. The zinc and carbon act on each other through the bath and will produce a flow of electric current between the zinc shell and the upper or exposed end of the carbon stick. The top of the cell is covered with pitch which retains the moisture on the inside, and around the outside of the zinc is a paper cover which insulates the cell from other pieces of metals or from other cells. At the upper end of the carbon is a small screw and nut for attaching a wire and on the upper edge of the zinc shell is another small screw and nut for attaching the other wire.

When the liquid of the bath or the electrolyte is used up or if the zinc shell is used up, the battery will no longer give a flow of current and is no longer of any use.

A lead storage cell, sometimes called an accumulator, is composed of two plates immersed in a bath or electrolyte which is contained in some form of jar covered at the top but not sealed tight.

The common storage battery plate is formed from a network of lead mixed with antimony to harden it. This net is called a grid and is filled with a paste made from red lead, litharge, water and sulphuric acid. The liquid around these plates is made from water and sulphuric acid and is called the electrolyte. The plates and liquid are contained in a glass, rubber or insulating composition jar.

If wires carrying electric current are attached to the two plates and the current allowed to pass through the storage cell the plates and the electrolyte will change their composition. If these wires are then de-

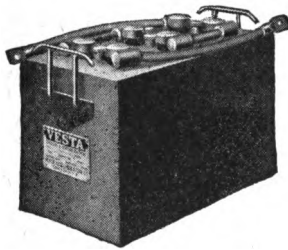

LIGHTING AND STARTING BATTERY.

Showing the heavy terminals and top connections necessary for this work.

tached a flow of current may be secured between the two plates of the cell. After this flow of current continues for some time the plates and electrolyte again change their composition and the cell will no longer give a flow of current.

The wires carrying the current may again be attached and the cell recharged, when it will again give a flow of current for some time.

Storage cells are made with two or more plates in each jar, the plates being connected in two sets, about

half the plates being in each set. Each of the two sets has a terminal attached so that a wire may be fastened to the cell.

When several cells are placed together in one box they are called a storage battery. This type is called the lead battery.

Another type of storage battery is the Edison battery which does not use lead plates but plates composed of and filled with compounds of nickel and iron. The electrolyte in place of being an acid mixture is an alkali, which is the opposite of an acid. Edison cells are charged and discharged in the same way as the lead battery, their advantage being that they are not so heavy as the lead cell. The disadvantage of an Edison battery is that it is not capable of discharging its current flow as rapidly as the lead cell.

The magneto, dynamo or generator all operate on the same principles and furnish means of changing mechanical power into electric current flow.

These instruments make use of the principles of induction and magnetism and their action and construction will be explained in the sections devoted to ignition and electric lighting and starting systems.

Direction of Flow. In a dry cell or storage battery the current is supposed to flow out from one of the terminals or wires, through the work and back into the other terminal or wire. This flow always continues in the same direction and is called a direct current.

The current generated in a dynamo, magneto or generator flows first out of one wire and into the other, then reverses and flows in at the first wire and out of the second. This current is then called alter-

nating current. Some dynamos and generators (all that are used in modern lighting and starting systems) are made to change the alternating current to a direct flow before it passes to the work. Magnetos always give an alternating current.

Polarity. The wire or terminal that the electric current flow comes out of is called the positive terminal or wire and the terminal or wire that it flows into is called the negative.

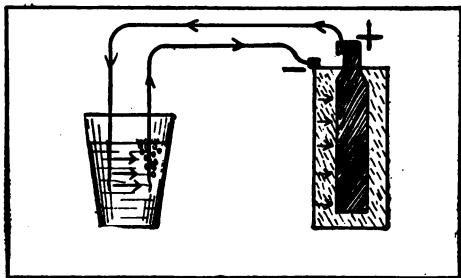

PASSAGE OF CURRENT FROM POSITIVE TERMINAL OF DRY CELL THROUGH CONDUCTOR AND BACK TO THE NEGATIVE TERMINAL.

Also showing how the negative wire bubbles in water.

If you want to find which of the two wires the current is flowing out of and which one it flows into it is only necessary to stick the ends of the wires into some water which has a little salt, vinegar or other acid mixed with it. Keep the ends of the wires from touching but bring them fairly near together. The wire that bubbles most is the negative, the other is the positive.

Connections. There are various combinations in use for connecting the positive and negative terminals

of cells and dynamos to each other. The same names are used when the same terminals of any electrical

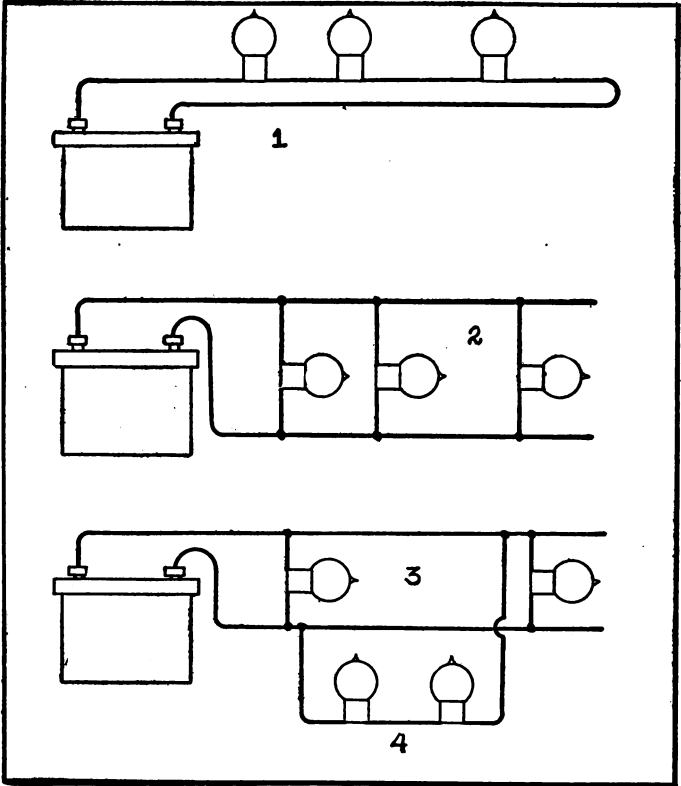

LAMP CONNECTIONS.

1, Series; 2, Multiple; 3, Two lamps in multiple with (4) two more connected in series on the multiple lines.

instruments or machines are connected in the same way whether the parts connected be cells, coils, electro magnets, dynamo parts or other parts.

A series connection is made when wires are run in such a way that all the current flowing in any part of the whole system flows through every other part and piece and wire, flowing from one to the next, through that piece and to the next one, etc. When cells or batteries are connected in series the positive terminal of one is attached to the negative terminal of the next, the positive of the second being attached to the negative of the third, etc. When lamps are connected in series their terminals are connected so that the wire coming from the battery or dynamo goes to one terminal of one lamp, the other terminal of that lamp leading to a terminal of the next lamp, the remaining terminal of the second lamp leading to the third one and so on until the last terminal of the last lamp is connected to the unused terminal of the battery or dynamo.

A multiple or parallel connection is made when all the positive terminals of the cells, batteries, lamps, or dynamos are connected to each other through one wire or set of wires, so that the positive terminal of any piece is connected to the positive terminal of every other piece. The negative terminals are then connected in the same manner.

A shunt connection is a form of multiple applied in a slightly different way. A wire or instrument connected in shunt with another piece or with a battery or dynamo is connected so that the current from the positive terminals is divided and part of it passes one way, through one part, while the balance of the current takes another path through another part. The current, after passing through the various parts connected in shunt is again collected and led back to the

negative terminal of the battery, cell or dynamo from which it started. If a second wire should be connected between any two terminals which are already connected by one wire this second wire would be connected in shunt with the first one and any instrument or part carried on the second wire would be shunted onto the first part. A third wire and part connected between the same two terminals would be in shunt with the first two and so on for any number of connections made.

A multiple-series connection is a combination of several parts, some of which are connected in series with each other and then these series sets are connected in multiple. The total number of parts might also be divided into sets with the pieces in each set connected in multiple and the sets connected in series.

Current Measurement. The electric current may be measured according to its various qualities such as pressure, quantity, flow and power.

Electricity flowing through a conductor is caused to flow against the resistance of the conductor by the pressure back of the current. This pressure may be great or small, much as the pressure in a pipe carrying water may be great or small. We measure the water pressure in the pipe by pounds to the square inch but we measure the electrical pressure by volts. The voltage in a line has nothing whatever to do with the power, amount or rate of flow only when considered in connection with other things. The voltage might be high or low while the flow might remain the same just as a water pipe carrying a flow of five gallons per minute might have a pressure of either ten or 100 pounds to the square inch. The voltage or pres-

sure causes the flow and power to increase providing all other conditions remain the same but neither power or flow is measured by volts. The only quality expressed in volts is the pressure or strength of the current in the conductor or the force with which it is passing from one place to another and with which it is overcoming the resistance.

The flow of water in the pipe could be expressed by the number of gallons per minute. This would only tell the rate of flow, not the total amount of water that flowed or the power it might have delivered nor the pounds of pressure on the water in the pipe. The rate of flow tells how much passes a certain point in a certain time. If the time were long then a large quantity would flow; if the time were short then a small quantity would flow but the rate of flow would remain the same in either case. The rate of flow of electricity is measured in amperes. Amperes do not measure the total quantity that flowed unless we know the length of time that the amperage flowed. Amperes do not measure electrical pressure, power or quantity but only the rate at which the current passes a certain point in the same way that we would say the water in a river was passing under a bridge at the rate of so many gallons per hour or minute.

Rate when applied to electrical measurement does not mean speed. Electric current always travels at a uniform speed, this being about 230,000 miles a second.

The total quantity of electricity is measured by ampere-hours. An ampere-hour is the quantity of current that would flow in one hour at a rate of one ampere. This corresponds to quarts or gallons of

water, being a definite quantity. Ten ampere-hours would be the quantity flowing in ten hours at a rate of one ampere, or it might be the quantity flowing in one hour at a rate of ten amperes. It might also be any combination of hours and amperes which would give ten when multiplied together. Thus, a flow of two amperes for five hours would equal ten ampere-hours.

The power that can be delivered by an electric current is measured by watts. Watts correspond to horsepower in being the power that may be delivered. To find the watts given by a flow of current we multiply the volts by the amperes. A current of thirty volts pressure having a flow of five amperes would give thirty times five, or 150 watts.

Seven hundred and forty-six watts of electrical power equal one horsepower or one watt is equal to one seven hundred forty-sixth of a horsepower.

The resistance of a conductor is measured in ohms. One ohm resistance is a resistance that allows one ampere to flow if the pressure is one volt. The resistance of a conductor is then expressed in ohms.

Volts, amperes and watts are measured directly by instruments called voltmeters, ammeters or wattmeters.

In order to use a voltmeter one terminal must be connected with the positive line or conductor or terminal and the other on the negative so that the pressure between the two may be measured. When testing the voltage in batteries or dynamos while they are delivering current it would be necessary to connect the voltmeter in shunt with the other parts or instruments. Voltmeters may be used for testing the volt-

age of any battery or dynamo or the voltage in any conductors.

In order to use an ammeter one of its terminals must be connected to the wire, battery or dynamo to be tested and then the wire or connection must be arranged so that all the current from that piece passes through the ammeter, out the other terminal of the ammeter to the connection which was on the part now connected to the first ammeter terminal. That is, the ammeter must be in series with the parts being tested. This usually makes it necessary to break a connection somewhere and insert the ammeter between the ends disconnected.

Never use an ammeter to test a storage battery unless the battery is installed in a car having an ammeter as part of the equipment or until you learn how to connect the ammeter safely according to the instructions given in the electric lighting and starting section. Never test a storage battery with an ammeter to see how much current it contains because the ammeter will be damaged.

A volt-ammeter is an instrument having a voltmeter and an ammeter in the same case. There are three terminals on a volt-ammeter, one being for use with either the voltmeter or ammeter, one of the others being used when voltage is to be measured and the remaining one being used when amperage is to be measured.

Ohm's Law. It has been discovered that the amperage in any conductor is equal to the voltage divided by the resistance in ohms. That is, the amperage may be found if the voltage and resistance of the line are known.

If the amperage and the resistance in ohms are known the voltage may be found by multiplying the amperes by the ohms.

If the voltage and amperage are known the resistance may be found by dividing the volts by the amperes.

MAGNETISM.

For practical purposes there are only two things that can be made into magnets or that are attracted by magnets: they are iron and steel. No other metals or substances can be magnetized nor are they attracted or acted upon by magnets or magnetism.

The theory of magnetism is that there are lines of magnetic force traveling in one direction through the

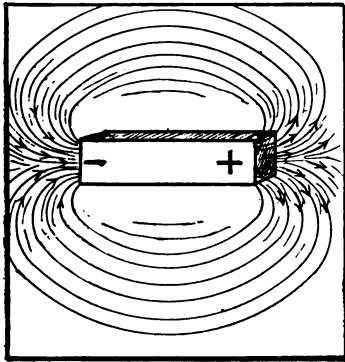

BAR MAGNET.

Showing path of the lines of force through the magnetic field.

body of any piece of iron or steel that is magnetized. These lines start in at one end and travel straight through the piece to the other end. When they reach the far end they emerge into the surrounding air and by taking a curved path around the outside of the magnet travel back to the first end and re-enter the

magnet. They then pass through as before and continue circulating in this way.

The end of the magnet from which the lines of force come out is called the positive pole or north pole of the magnet. The end that the lines of force go into is called the negative pole or the south pole of the magnet.

The negative pole of one magnet will attract or pull the positive pole of another magnet to it, or the positive pole will pull a negative pole to it. Two negative poles have no attraction or pull for each other and two positive poles have no attraction for each other. In fact, two poles of the same kind tend to repel each other, that is, they try to keep away from each other. We say that unlike poles attract and like poles repel each other.

When we wish to use the pulling power of a magnet we make it in a straight piece from end to end and call it a bar magnet. When we wish to generate electric current with the help of magnetism we use the lines of force traveling between the positive and negative pole of the magnet. In order to bring these lines into a more straight path we bend the magnet until it is in the shape of a capital letter U or a horseshoe or part of a circle. This brings the ends nearer together so that the lines of force can take a fairly straight path between the poles. This type of magnet is called a horseshoe magnet or U shaped magnet. For special purposes magnets are made in the shape of a capital letter V and in many other forms to fit the place they are intended for.

When two or more magnets are placed tight together in such a way that the negative poles are to-

gether and the positive poles are together the magnets help each other by adding their strength together and the set is called a compound magnet.

If a magnet is suspended or hung at its center so that it is free to swing in any direction the positive or north pole will turn around until it points toward the north and the negative or south pole will point toward the south. When a very small and light bar magnet is set on a pivot so that it can turn it is called a mariner's compass, or just a compass.

It is supposed that a magnet becomes weaker from having the lines of force pass through the air from one pole to the other. It is hard for the lines of force to pass through the air and they slowly become weaker and weaker. To prevent the magnet's weakening so soon a piece of iron or steel may be laid on the magnet from one pole to the other. The lines of force will then travel through the piece of iron or steel more than through the air. It is easier for the lines to travel through the iron or steel than through the air and the magnet does not weaken so soon. This piece is called a keeper or an armature of the magnet. When magnets are removed from a magneto or dynamo a keeper should always be placed across the ends.

A piece of hardened steel when magnetized will remain a magnet for a long time, years in most cases. It is then called a permanent magnet. A permanent magnet becomes weaker with age and use. It becomes weaker very fast if heated or jarred or hit in any way.

A piece of iron will not retain its magnetism, although it may be easily magnetized. The softer the iron, the quicker it loses its magnetism after being

magnetized. Very soft iron remains a magnet only so long as the force is present that makes it a magnet and as soon as this magnetizing influence is removed the iron is no longer a magnet.

Iron or steel may be magnetized by touching or rubbing another magnet on the piece of iron or steel. They may be magnetized by having current passed through a coil of wire wound around the piece or they may be slightly magnetized by being near a powerful magnet or near electrical machinery. A piece of steel may be magnetized by holding it so it points north and south and tapping it with a hammer. The end pointing north will then be the north or positive pole and the end pointing south will be the negative or south pole.

The easiest way to find which pole is which on a magnet is to have another magnet or compass, on which the poles are known. The poles of a compass are always known because the positive pole points north. It is then only necessary to remember that a pole attracted by the positive pole of the compass or the known magnet must be the negative pole of the tested magnet.

The part of the air surrounding a magnet through which the magnetic lines of force travel is called the magnetic field. As the lines of force are thickest at the poles the magnetic field is strongest at or near the poles and weakest half way between the poles.

If there is a keeper or an iron or steel path between the poles the lines of force will remain in this metal path for the greater part, only a comparatively small number passing through the surrounding air. In this way the magnetic field may be confined to and made

to occupy a comparatively small space. Even if a piece of iron or steel does not touch the poles or if it only occupies a small part of the space between the poles the lines of force will collect as far as possible and pass through this piece of iron or steel in their path from one pole to the other.

Unless there is a path of iron or steel between the poles or somewhere in the magnetic field the lines of force will take their natural curved paths from pole to pole. Lines of force easily pass through wood, glass, rubber, paper and all metals. There is nothing that prevents the passage of magnetic lines of force except distance. The only way to confine the field is to provide an easy path for the lines of force.

The magnets so far considered have been permanent magnets of steel which hold their magnetism indefinitely. A form of magnet even more useful than the permanent magnet is called the electro magnet. An electro magnet is a soft piece or a number of pieces of iron, around which is wound a coil of insulated wire through which electric current may flow. The coil of wire is in no way connected to the iron. The iron must be very soft and it is called the core of the magnet.

Whenever a current of electricity passes through the coil of insulated wire which is wound around the core the core becomes a magnet with a positive and negative pole and all the other characteristics of a magnet. As soon as the current stops flowing through the coil or winding of the electro magnet the core is no longer a magnet and loses the properties of a magnet.

The poles of an electro magnet may be found in the same way as if it were a permanent magnet, by

testing with another magnet or compass. There is another way of knowing which pole is which and of making either end into either pole. This is according to which way the current passes around the magnet.

Looking at one end of the electro magnet, start with the end of the winding that comes from the positive source of current. If this wire starts and winds around the core in the same direction that the hands of a clock move, the end of the core that you are looking

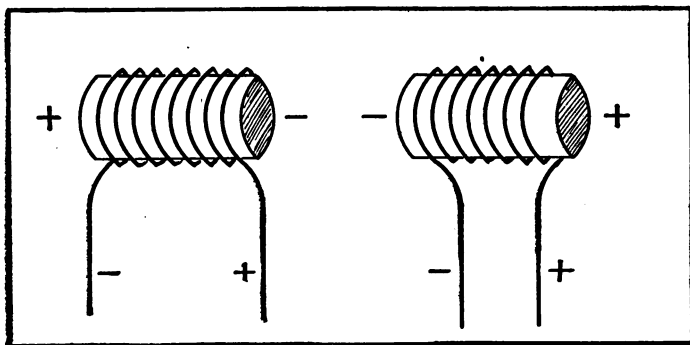

ELECTRO-MAGNETS.

Current passing around in clockwise direction, causing negative pole (at left). Current passing anti-clockwise, causing positive pole (at right).

at is the negative pole and the other end will be the positive pole. If the wire passes around the core in a direction opposite to the way the hands of the clock travel or anti-clockwise, the end of the core that you are looking at will be the positive pole and the other end will be the negative.

By connecting the wire that originally came from the positive terminal of the source to the other end of the electro magnet winding the poles will be re-

versed, the one that was positive will then be negative and the negative will be positive.

The strength or pull of an electro magnet depends on the number of turns of wire in the coil and on the number of amperes of current passing through the coil. When one turn or wire around the core carries one ampere it is called an ampere-turn. Five turns carrying one ampere would give five ampere-turns. One turn carrying five amperes would also give five ampere-turns and either magnet having five ampere-turns would be as strong as the other one. Ten turns carrying one-half an ampere each would also give five ampere-turns and the same strength. By multiplying the number of turns around the core by the amperes passing through the winding we find the strength of the electro magnet in ampere-turns.

If the core of an electro magnet could be removed, leaving only the coil of wire, this coil would be called a solenoid. If the core of the electro magnet should then be brought to the end of the hole through the solenoid while current was passing through the winding the core would be pulled into the hole. If the core is placed a little ways into the hole of the solenoid and the current then passed through the solenoid the core will be drawn into the solenoid until it is in the center of the coil. The strength of the pull of a solenoid on its plunger is measured in ampere-turns through the winding of the solenoid.

INDUCTION.

Induction is generally understood to mean the producing of an electric current in a conductor when the conductor is brought into a magnetic field and then removed from the field, or, when the conductor remains stationary and the magnetic field becomes alternately stronger and weaker, or, when the direction of the magnetic lines of force changes from one way to the other.

Coils. Induction of current is produced in a coil of insulated wire by a magnetic field from either a permanent or an electro magnet. The arrangement and relative location and type of the coil and magnet determines the type of apparatus and its suitability for different uses.

There is no electrical conducting connection between the magnet (permanent or electro) and the wire or conductor in which the current is induced or produced by induction.

For purposes of ignition we require a current of very high voltage, so high that it is capable of forcing the current to jump across an air gap in the cylinder and produce the spark that fires the charge. This requires a voltage of thousands and it is not practical to make either batteries or cells or dynamos that will produce such a voltage. We therefore produce a comparatively low voltage, four to twenty-five, and by means of induction in a transformer coil we secure a current of very high voltage.

If we take a core of soft iron with a winding of only several hundred turns of ordinary size insulated wire on it we have an electro magnet. By causing the current to flow in the coil and then stop flowing we make the iron core into a magnet and then cause it to lose its magnetism.

If now we wind another coil around the outside of

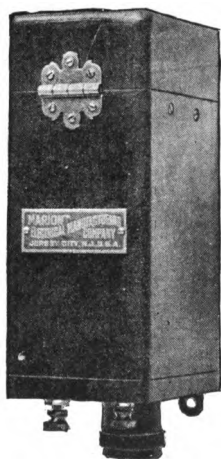

HIGH TENSION TRANSFORMER COIL.

the first one (on this electro magnet), but make the second coil of thousands of turns of very fine wire, it will be seen that the magnetic field of the core first surrounds and passes through the second coil of fine wire and when the current ceases to flow in the coil of ordinary sized wire the magnetic field disappears. This action changes the strength of the magnetic field passing through the fine wire coil from the highest

ELECTRICITY

power to zero each time the current flows and ceases to flow in the first coil around the core of the magnet.

When the low voltage current is allowed to pass through the coarser winding on the first coil the magnetic field of the core becomes strong and extends out through the fine wire coil. When the current ceases to flow in the first coil the magnetic field disappears and as the magnetic field leaves the fine wire coil a current of very high voltage is induced in the fine winding.

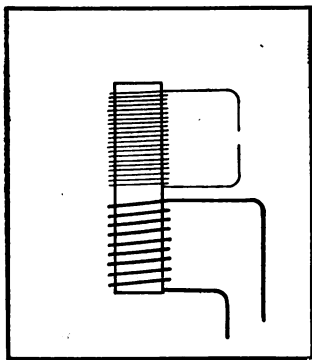

PRINCIPLE OF THE INDUCTION COIL.

This current may then be used for causing the spark to jump in the cylinder and fire the charge. The core with its two windings is called a transformer coil.

The power or the watts of the current were not increased by the transformer coil. The amperage in the coarse wire inner coil was from one-half to one ampere and the voltage usually from six to eight. This would make three to eight watts (found by multiplying the amperes by the volts).

The current coming from the fine winding, while hav-

ing a voltage of perhaps 50,000 to 100,000 volts, would have only one twenty-thousandth part of one ampere, so that the power or watts would not be increased.

If a current of very high voltage was passed through the fine wire coil a current of low voltage would be received from the coarse wire coil, but the amperage would be greater in the low voltage current so that the watts would not be changed.

A fine wire carrying the induced current raises the voltage and if the wire carrying the induced current is larger than the other one its voltage will be lower. The proportion of the size of the wires on the two windings and the number of turns of wire determines the change of voltage up or down and the amount of the change.

The current received from an outside source and sent through the winding that magnetizes the core is called the primary current and the current received from the winding in which it is induced by the changing magnetic field is called the secondary current.

In automobile work the primary current is always the low voltage current and the secondary current is always of high voltage. All wires and parts carrying the primary current are called primary wires and parts and all wires or parts carrying the secondary current are called secondary wires or parts. The coil receiving the current from the outside source is called the primary coil and the coil in which the current is induced is called the secondary coil.

The low voltage current on an automobile is called low tension current and the high voltage current that jumps the gap to make the spark is called high tension current.

In magnetos and dynamos the coil of wire is made to move in such a way that the lines of force first pass through the armature coil in one direction and then in the other direction so that the magnetic strength alternately rises, falls to zero and then rises again. Moving the coil in this way while it is in the magnetic field requires considerable power and in this way mechanical power is changed into electric current.

In some forms of generators and magnetos the coil remains stationary and the lines of force are caused to change their direction by revolving pieces of iron between the poles of the magnets.

The action of magnetos and dynamos will be more fully explained under Ignition and Electric Lighting and Starting Systems.

SECTION FOUR

ELECTRIC LIGHTING AND STARTING.

ELECTRIC LIGHTING AND STARTING.

Electric lighting for motor cars has been used almost as long as the cars themselves have been on the market. This early electric lighting, however, made use only of dry cells or storage batteries as the source of current. When the current was exhausted the dry cells were replaced with new ones or the storage batteries were removed from the car and recharged from an outside supply.

Because of the uncertainty of the length of time that the lights would burn on one battery charge and the inconvenience of removing the battery for recharging or of replacing the dry cells, this proved a rather unsatisfactory method and was only used for small lamps, usually tail or side lamps. Installations were made for headlights also but the large drain on the battery made it necessary to carry an excessively large battery weighing in many cases over one hundred pounds.

At the time the battery systems were in use another form of electric current source came into use. This was the small dynamo or generator run from the engine by belts or gears, or often by friction wheels on the fly-wheel. This dynamo would give a fairly constant voltage when the car was running above a certain speed, but below this speed the voltage would not be sufficient to light the lamps properly. These dynamos could be used for the headlights very easily because the headlights were not so necessary when the car was running very slowly or standing.

4 ELECTRIC LIGHTING AND STARTING

The next step was to fit the car with a medium size battery and also with a direct current dynamo which would keep this battery charged, the dynamo being run from the engine and delivering its current into the battery. The lamps could then be burned from the battery and the entire system would practically maintain itself on power received from the engine. This formed the basis of the modern systems of electric lighting.

After having a battery that would remain charged it was a simple matter to attach an electric motor to the engine so that when current from the battery was made to revolve the electric motor the motor would start the engine in the same way that the driver would do with the hand crank.

Since the possibilities of automatic and continuous battery charging were realized many electric attachments have been built into the newer cars, among them being electric gear shifters, electric brakes, electric horns, cigar lighters, steering wheel warmers, foot warmers, and almost anything that could be operated by electric current. Some of the modern cars have more electrical parts than gasoline, the electric control even extending to electric transmission in place of the ordinary gearing.

Electric lighting and engine starting systems came into sudden prominence in 1911 and gained rapidly as standard equipment on all classes of cars during the following years. In 1913 it was estimated that over 70 per cent of all cars (except Fords) had this equipment for lighting only or for lighting and starting. In 1914 the percentage was even greater and for 1915 it was hard to make a list of cars without electrical equipment of this kind.

ELECTRIC LIGHTING AND STARTING Section 4 5

There are dozens of different makes of electrical equipment, each maker building his outfit a little different from all others. However, a great many of these systems are made up from parts secured from established electrical manufacturing houses and all systems are made by different combinations of more or less standard principles so that it is possible to study them all by understanding these underlying principles and methods of building. It is of course true that this re-

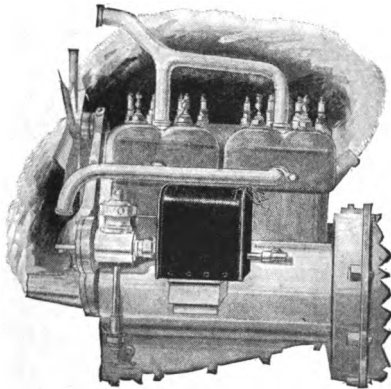

ENGINE SHOWING DYNAMO MOUNTED IN PLACE OF MAGNETO.

quires careful study and a thorough understanding of electrical principles already explained as well as those to come. The repairman must be able to recognize or discover how any installation is made and controlled and by understanding each of the parts it will be easy to understand their workings in connection with each other. It would be useless to attempt a study of every different system for the reason that they would be so confused in the learner's mind that the study would be

practically useless. Even if a man could learn the characteristics of every make, their design and construction might be more or less radically changed for next year. We will therefore take up each part of the system required on any car and then study the various ways of building this part.

PARTS REQUIRED.

Dynamo or Generator. A dynamo is an instrument which changes mechanical power into electric current. Generator is another name for dynamo.

The dynamo is connected to the engine by means of

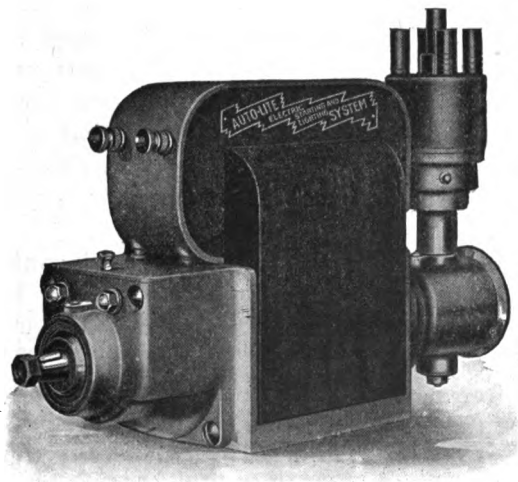

AUTOLITE DYNAMO, SHOWING HOW THE IGNITER IS ATTACHED.

gears, chains or possibly belts so that the dynamo runs and makes current whenever the engine runs. The dynamo usually runs at about three times the crankshaft speed, although in some installations it runs at

crank-shaft speed or more than three times crank-shaft speed. Current from the dynamo is used to charge the storage battery, light the lamps, and, through the charged battery, it starts the engine.

Storage Battery. The storage battery receives the current from the dynamo that is not immediately used for lighting the lamps and stores this current until wanted for use to start the engine or for any purpose that requires more current than the generator is making, or, while the generator and engine are idle. The storage battery also serves the same purpose that an open tank of water would serve in a water pressure pumping system, that is, it maintains an even pressure or voltage in all parts of the system at all times. In this way it acts as a voltage regulator, constant voltage being necessary for the successful operation of the lamps.

Generator Control. In order that the dynamo may successfully charge the battery and that the battery may retain its charge until wanted for proper use two things are necessary.

(1) After a battery has been charged for a certain length of time it is said to be fully charged and should not receive too heavy an overcharge after this time.

It is also considered necessary to charge the battery at a flow of only a certain number of amperes and the rate of charge should not exceed this number.

To limit the charging rate or to prevent excessive overcharge some form of current regulation is necessary. This may be taken care of in the design of the dynamo or it may be accomplished by additional instruments outside the dynamo. These instruments are called regulators and the action is called regulation.

(2) As long as the generator runs at a fair rate of speed it will make a voltage higher than the voltage of the battery, and, inasmuch as the pressure at the dynamo is greater than the pressure at the battery, current will flow from the dynamo to the battery and the battery will be charged. Should the dynamo speed fall

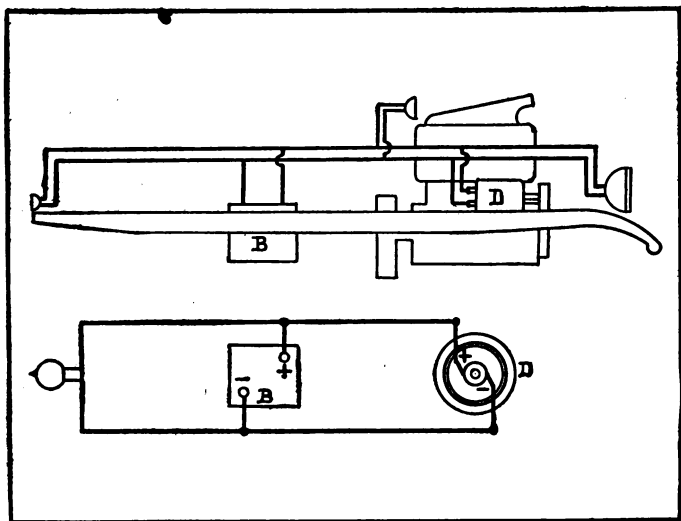

UNITS OF A SELF CONTAINED ELECTRIC LIGHTING SYSTEM.

Arrangement of parts on car shown above with connections for "floating battery on the line," shown below. D, dynamo; B, battery.

below the point at which it makes a voltage higher than the battery voltage or should the generator stop (as it does when the engine stops), then the battery pressure would be greater than the dynamo pressure and the current already in the battery would flow to the generator and the battery would be discharged.

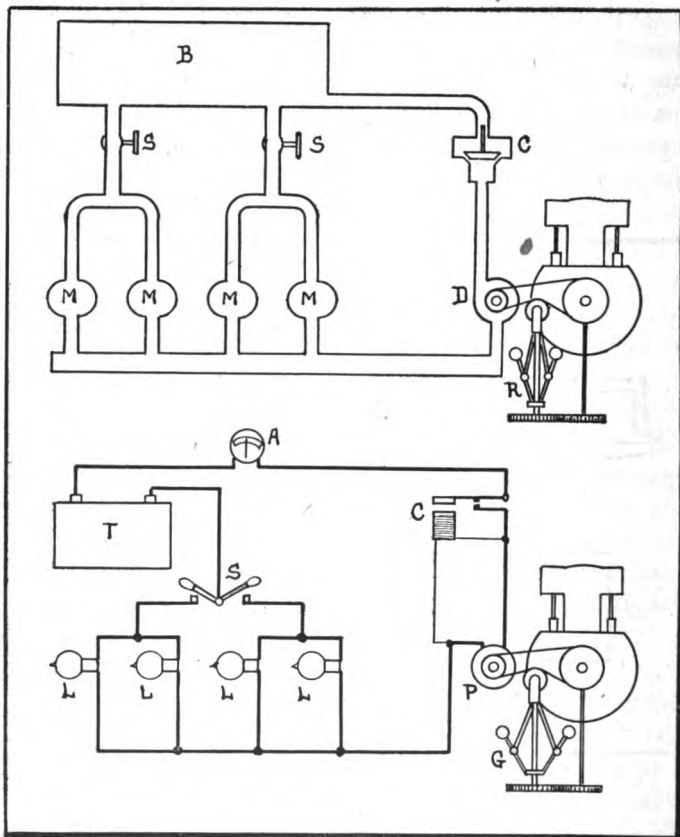

SIMILARITY BETWEEN THE FLOW AND ACTION OF WATER AND ELECTRICITY.

Upper Diagram—D, Water pump driven from engine, its output being controlled by the governor (R) loosening the belt tension above certain speeds; C, Check valve preventing leakage of water from tank through pump when pump is idle; B, Water storage tank; S, Valves for admitting water to motors from tank; M, Water motors driven by water from tank.

Lower Diagram—P, Dynamo taking place of the pump; G, Regulator acting as governor; C, Cut-out preventing current leakage through dynamo; A, Ammeter showing flow of current; T, Storage battery; S, Lighting switches; L, Electric lamps.

To prevent this discharge of the battery all forms of systems have some form of instrument or attachment that breaks the circuit between the battery and dynamo when the dynamo voltage falls below that of the battery for any reason whatever. This part of the system is called the reverse current cut-out or simply the cut-out.

Current Indicators. When it is desired to know the flow in amperes that is passing into the battery from the dynamo and the flow from the battery in amperes to the lamps or other accessories (except the starting motor) an ammeter is attached to one of the battery terminals so that all current passing into or out of the battery, except that to the starting motor, is indicated by the ammeter at the time of current flow. The amperage of the current flowing to the starting motor is so great that an ammeter capable of registering it would not be suitable for the finer work of charging and lamp current measurement.

If it is also desired to know the voltage of charging, a voltmeter is connected to the positive and negative sides of the charging wires from the dynamo to the battery in such a way that the voltage is indicated whenever the battery is being charged, but protected by the cut-out so that the battery cannot discharge through the voltmeter.

Switches. In order to control the passage of the electric current from one part of the system to another so that it may be used when desired, various forms of switches are provided that may be operated (opened or closed) by the driver. Switches are placed in the lines going to the different sets of lamps as head,

12 . ELECTRIC LIGHTING AND STARTING

side, tail, dash, etc., to the starting motor and to any other parts that sometimes require current.

Wiring. The various parts of the system will be connected by wires arranged in such a way that the processes of battery charging, lighting and engine starting may be accomplished. In some cases these wires are provided with fuses at some point in their travel so that should too great an amperage pass through the wire the fuse will melt and break the circuit. Too great an amperage might destroy the lamps, damage the battery or burn out some of the wires or coils on the car. The fuses prevent this, and by burning out call attention to the trouble that caused the excessive flow, and are themselves easily replaced.

When two or more wires are to be joined at some point on the car the joint is often protected with a small metal box inside of which the joint is made. This box has a cover screwed on and protects the joint against weather and accidental damage. This type of covering is called a junction box.

Should it be convenient to bring a number of wires to a point on the dashboard or some other accessible place, the insulating plate to which they all lead is called a distribution panel. The switches are often mounted on a distribution panel.

Starting Motor. Attached to the engine by gears or chains is an electric motor. When current from the battery is sent to this motor through the starting switch it causes the gasoline engine to turn rapidly enough to start the engine. There are only four parts to the starting system: the motor, the starting switch and the wires connecting the motor and switch to the battery. The gearing through which the motor is con-

nected to the engine is considered as part of the starting system.

Systems in Use. It is a peculiar property of electric machines that they will act either as a dynamo, turning power into current, or as a motor, turning electric current into power. No change whatever is necessary. Whenever the dynamo is caused to turn fast enough

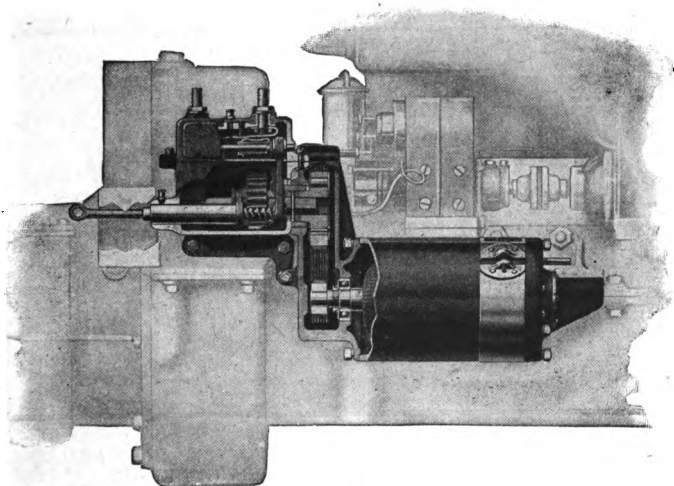

STARTING MOTOR INSTALLATION.

Drive to flywheel through gear reduction and overrunning clutch, gears being slid into mesh by the same movement that closes the starting switch. The starting switch is on top of the gear case.

so that its voltage is higher than that of the battery it will act as a dynamo and charge the battery. Whenever the current coming from the battery is higher than that of the dynamo in voltage the dynamo will act as a motor and deliver power. This fact is taken advantage of in some systems which have only one unit,

14 ELECTRIC LIGHTING AND STARTING

which acts as a motor to start the engine, then as a dynamo to charge the battery when driven by the engine. This arrangement is called a single unit system with a motor-generator.

A generator may easily be used in place of a magneto by attaching the parts necessary for transforming the current to one of high voltage and the parts that

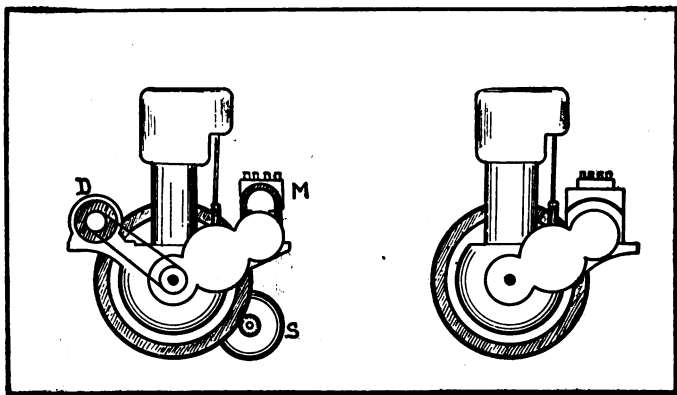

THREE UNIT OR SEPARATE UNIT SYSTEM (AT LEFT) AND ONE UNIT OR COMBINED UNIT SYSTEM (AT RIGHT).

cause the spark to come at the right time and in the right cylinder. When the dynamo and magneto are combined in one unit we would have a two-unit system with a generator-igniter.

When dynamo, starting motor and magneto are separate from each other the system is called a two or three-unit system or a separate unit system.

In some types the dynamo, starting motor and mag-

neto are all combined in one unit and the system is then called a single unit or combined unit system.

The separate unit system is used in a majority of

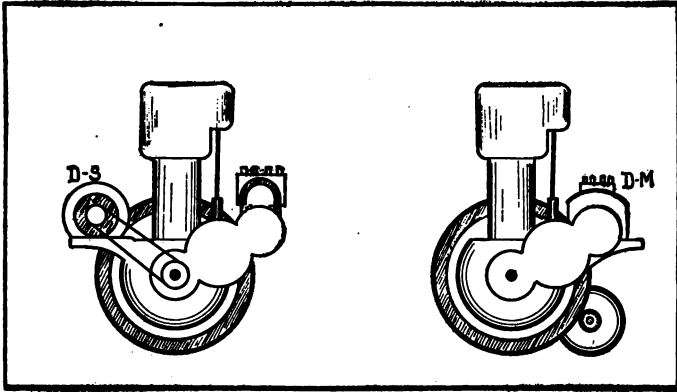

TWO UNIT SYSTEMS.

COMBINED DYNAMO AND STARTER WITH SEPARATE MAGNETO (AT LEFT) AND COMBINED DYNAMO AND IGNITER WITH SEPARATE STARTER (AT RIGHT).

installations, the combined motor-generator coming next in popular favor.

THE DYNAMO.

The dynamo used in automobiles is composed of (a) the armature which carries coils of wire in which the current is generated, (b) the fields, which are the magnets producing the lines of force that pass through the armature coils, (c) the commutator, which changes the alternating current produced in the coils to a direct current for charging the battery, (d) the brushes, which collect the current from the commutator and the case



"REX" LIGHTING GENERATOR WITH CUT-OUT AND REGULATOR IN SAME CASE.

which encloses these parts, also the separate pieces and attachments which make up these parts.

The dynamo generates current by induction, the coils on the armature being so arranged or moved that the lines of force first increase then decrease in the coil and in so doing change their direction of travel through the coils.

Construction and Theory. To understand the action

of the dynamo in generating current first consider that the ends of two magnets are separated by a space of three or four inches. If one of these ends is a positive pole and the other a negative pole there will be magnetic lines of force passing through the air from the positive to the negative pole.

Now imagine that there is a piece of soft iron placed between the poles. The lines of force would then travel through the iron from one pole to the other. Next imagine that this piece of iron between the poles is carried on a shaft passing through its center at right angles to the lines of force. The iron can then be turned on the shaft so that the end that was nearest the positive pole will be nearest the negative and the end that was nearest the negative will be nearest the positive. The lines of force would then be passing through the iron piece in the opposite direction to what they were before the iron was turned end for end.

When the iron piece is turned only half way so that it stands at right angles to the path of the lines of force, the lines will not travel through the length of the iron but across the piece. When the iron is slowly turned from this last crosswise position the ends of the iron will gradually come closer to the ends of the magnets until the lines of force will take up their path through the length of the iron piece once more. When the ends of the iron piece are directly opposite the ends of the magnets the lines of force will have the easiest path but as the turning of the piece on the shaft is continued it will become harder and harder for the lines of force to travel through the iron until just before the iron is crosswise between the magnets, the lines of force stop passing through the length of the piece

Section 4
18 ELECTRIC LIGHTING AND STARTING

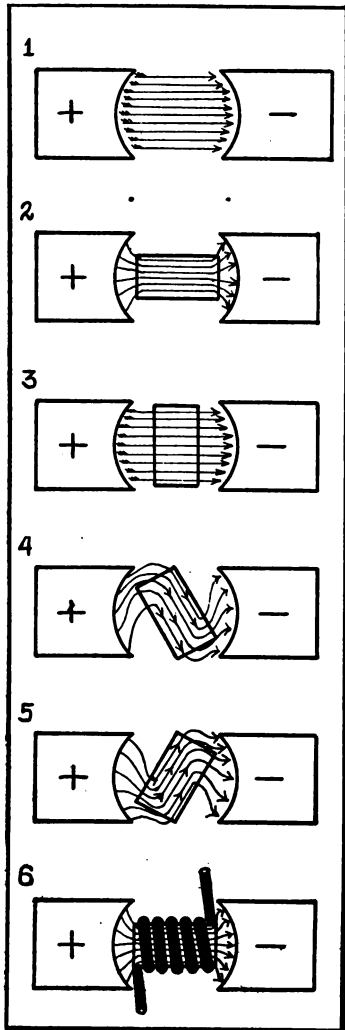

PRINCIPLE OF DYNAMO ACTION.

of iron. As the iron continues to turn it will come into the position where the lines of force will again pass through its length. It will be seen that each time the piece of iron makes one complete turn the direction of the lines of force through the iron changes its direction twice, the strength of the lines of force through the piece of iron decreases and then increases twice.

Now, if we wind a coil of wire around the piece of iron that is carried on the shaft between the magnets, the path of the lines of force through the center of the coil of wire (which is filled by the piece of iron) will be the same as the path of the lines of force through the iron alone. That is, the strength of the lines of force through the coil will increase and decrease twice during each revolution. It will be remembered that when the strength of the magnetic field or lines of force is increased and then decreased in or around a coil of wire a current of electricity is induced or generated in the coil of wire. This is the principle of the electric dynamo.

Fields. The fields or field magnets of the dynamo are the magnets that produce the flow of magnetic lines of force in which the coils of the armature are carried.

In many cases the field magnets are U shaped or horseshoe shaped, the armature with its coils being carried between the ends or poles of the magnet. Inasmuch as there is a flow of magnetic lines of force between the poles it is possible to cause them to pass through the coils of the armature and generate the current as the armature is turned.

Some dynamos have permanent field magnets, others have electro-magnets for the fields, these electro-mag-

nets receiving their current from the current produced by the dynamo.

Inasmuch as the armature is intended to rotate it is made round. It is desirable that the air space between the iron of the armature and the ends of the magnets be as small as possible, just enough so that the armature iron will not actually touch the ends of the magnets. In order to bring the poles or ends of the

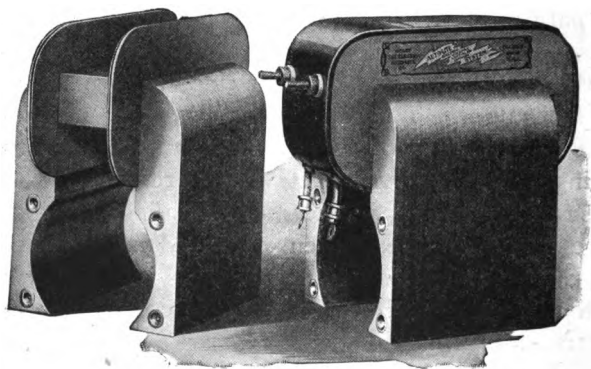

FIELD MAGNETS, BEFORE AND AFTER APPLYING THE WINDINGS.

magnets very close to the armature these ends are extended to within one-thirty-second of an inch or less of the armature and are made hollow so that the two poles or ends form a cylindrical shaped tunnel for the armature to turn in. The two poles do not actually touch each other but enclose the armature so that the poles are only about one-half to one inch apart. These extensions of the magnet ends are called the pole pieces. They are sometimes in one piece with the mag-

net, sometimes separate pieces fastened to the ends of the magnet. The hole that the armature turns in is called the armature tunnel.

The field magnets are fastened to the case that encloses the parts of the dynamo, the case often forming a part of the body of the magnet.

Armature. In order that the dynamo may generate

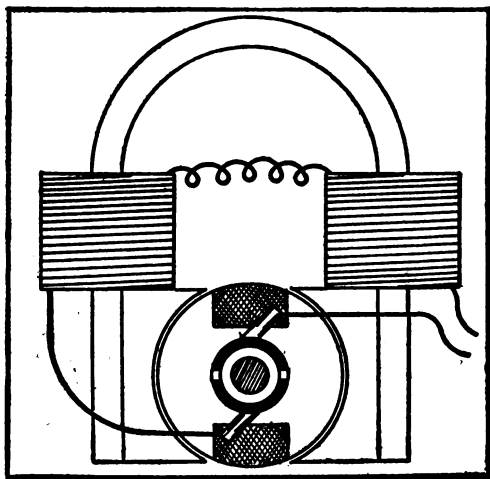

DYNAMO OR MOTOR FIELD WINDINGS.

a fairly large quantity of current the armature usually carries a number of coils, from eight up to twenty or thirty. It will be seen that with a large number of coils the flow of magnetic lines of force is always changing in one of them so that the current produced by an armature of many coils is more steady and continuous in its flow than would be the case with only one coil. In order to make this flow even more steady and uni-

form dynamos are built with more than two fields so that there are four, six or eight poles sending lines of force through the armature coils, half the poles being positive and the other half negative. This type of machine is called a four, six or eight-pole dynamo.

When the lines of force pass through the armature coil in one direction, the induced current in the coil flows around the coil in a certain direction. When the direction of flow of the lines of force through the coil

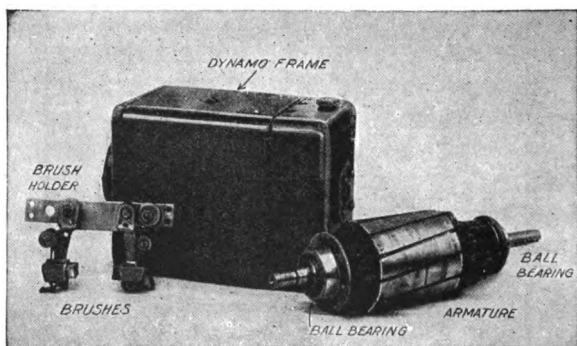

DYNAMO PARTS.

is reversed the flow of induced current around the coil is also reversed.

If one end of a coil delivers positive current the other end will be negative. The terminals of the coil will continue this way during half the revolution of the armature. During the other half revolution of the armature the flow in the coil is reversed so that the end that was negative is now positive and the end that was positive is now negative.

If we collect the electric current from the armature coils just as it is produced, the flow will first be in one direction and then in the other, this current being called an alternating current. In order to charge a storage battery it is necessary that the flow be continuous in one direction. This makes it impossible to charge a battery with an alternating current.

The iron of the armature on which the coils are wound is called the armature core and the coils are called the armature windings.

Commutator and Brushes. The purpose of the commutator is to give all the positive current flow from the armature to one wire of the circuit and to give all the negative flow from the armature coils to another wire of the circuit so that one wire will always be positive and the other one will always be negative.

On one end of the armature shaft is placed a copper cylinder which extends all around the shaft. This cylinder is cut into as many sections (running lengthwise of the shaft) as there are ends of the armature coils. That is, there will be twice as many pieces in the copper cylinder as there are coils because each coil has two ends. For the purposes of explanation we will consider a commutator or cylinder divided into only two parts, each part extending half way around the shaft. This would be suitable for an armature having only one coil.

We will now mount two brushes (pieces of carbon or copper) so that one brush touches the cylinder or commutator on one side and the other brush touches it on the other side directly opposite. These brushes will remain stationary while the commutator and armature turn.

With the armature coil in position so that the magnetic lines of force flow straight through its center we will place one of the brushes so that it is touching one half of the copper cylinder at one end of the half so that as the commutator is turned this half will pass under this brush during half a turn.

The other brush, being directly opposite, will be at

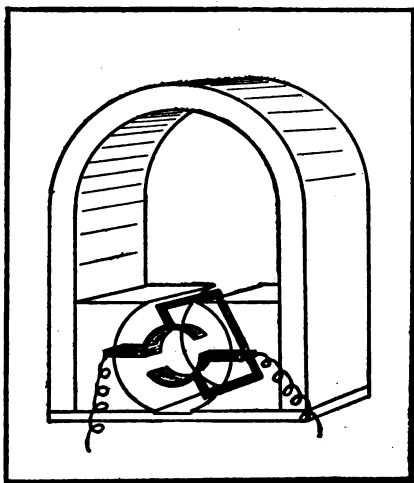

PRINCIPLE OF THE ARMATURE COIL, COMMUTATOR AND BRUSHES.

the end of the other half of the copper cylinder and as the cylinder turns this other brush will stay in contact with that half of the commutator for the same half turn.

One end of the coil is attached to one-half the commutator, the other end being attached to the other half.

It will be remembered that one end of the coil de-

livers positive current during half a revolution while the other end of the coil is negative during the same half revolution.

Inasmuch as one end of the coil is attached to one-half the commutator and one-half the commutator will be in contact with one brush during half a revolution, it will be seen that this brush will receive positive cur-

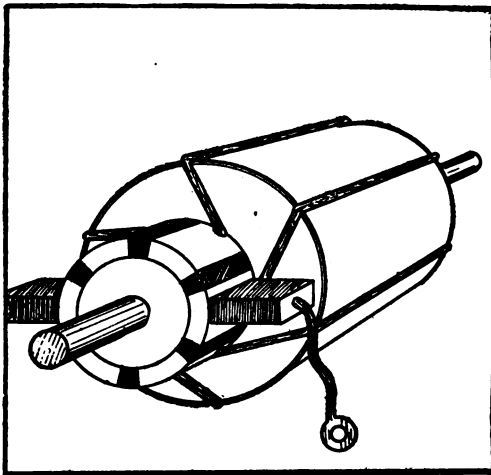

ARMATURE WINDINGS ATTACHED TO COMMUTATOR BARS.

rent during this half revolution. For the same reasons the other brush will be negative at this time.

When the coil has made a half revolution, the side that was going down and delivering positive current will start up and will then become negative. The half of the commutator attached to this side of the coil will pass from under the positive brush and will come in contact with the negative brush on the other side at

Section 4
26 ELECTRIC LIGHTING AND STARTING

the same time that the coil stops delivering positive current and becomes negative. The other end of the coil (with its half of the commutator) will have passed under the positive brush just as it starts to deliver a positive flow so that one of the brushes is always in contact with the part of the commutator that receives positive current while the other brush is always in contact with the side or half of the commutator that is negative.

One of the brushes is called the positive brush and



BRUSH WITH PIGTAILS ATTACHED.

the other one the negative brush, the brushes being attached to the positive and negative wires.

The parts of the commutator are called commutator segments or commutator bars and they are separated and insulated from each other with thin pieces of mica or other insulating material.

The brushes are connected to the wires leading from the dynamo by small flexible pieces of wire attached to the brush which are called pig tails.

The brushes are carried in some form of insulation and this insulation is held by the brush holder. The brush holder is fastened to the frame or case of the

dynamo. In order to keep the brushes in contact with the commutator there are small flat or coiled springs held by the brush holder which keep the brush up to its work. These springs always have some means of increasing or decreasing the pressure on the brushes.

Brushes are made from a very fine, smooth, soft grade of carbon or from a mixture of carbon and graphite or from copper or from copper and carbon made together.

There are always as many brushes for collection of current as there are poles or ends of magnets in the fields. There may also be additional brushes that collect current from the commutator or deliver current to the commutator for purposes of regulation.

Dynamo Current Output. The current delivered from the dynamo is measured in volts and amperes. However, the voltage in all the lines of wire on the car is determined by the voltage of the battery, the battery holding the voltage practically the same as its own pressure under all conditions. The actual voltage delivered by the dynamo can therefore be neglected, as it has no effect on the system.

The output of the dynamo in amperes is very important, both that it be enough to keep the battery properly charged at all times under normal or abnormal conditions and that it is not too great for the good of the battery in charging.

The output of the average dynamo at ordinary car speeds is from ten to twenty amperes. The output required depends on the amount of current needed by the lamps, starter and other devices on the car and also on the size or capacity of the battery in ampere hours. The size of the battery really depends on the amount of

current required to be held in reserve for the various electrical parts, the dynamo size therefore depends on the current requirements of the car.

If all the current-consuming devices be placed in operation at one time (all lamps and other devices ordinarily used), the ammeter will show the number of amperes being drawn from the battery. The lamps, etc., may then be turned off so that there is no withdrawal from the battery and the engine run at a speed

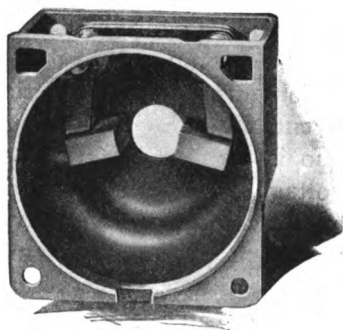

COMMUTATOR HOUSING WITH BRUSHES AND BRUSH HOLDERS.

that would correspond to about fifteen miles per hour or the car may be run on the road at this speed.

The amperes delivered by the dynamo at this speed with all the current consumers out of use and the current in amperes drawn from the battery with the engine idle and all devices turned on should be just about equal. That is, the output of the dynamo at fifteen miles per hour should be the same as the requirements of all the lamps, etc. This will keep the battery properly charged.

The greatest amount of trouble in all systems in general is from discharged or partly discharged batteries. The importance of proper generator output may be realized from this fact.

The capacity of the storage battery is measured in ampere hours. As explained, the ampere hour is the amount of current delivered in one hour at a flow of one ampere and the ampere hour capacity of the battery is the number of amperes the battery would deliver for one hour or the number of hours that the battery would give a flow of one ampere. Thus a 120-ampere hour battery would give a flow of one ampere for 120 hours or (theoretically) a flow of 120 amperes for one hour or any other combination of hours and amperes which multiplied together would equal 120.

The current output of a dynamo in amperes is supposed to be not more than one-eighth of the battery capacity in ampere hours under any conditions.

From the above you will see that the capacity of the battery must be enough so that the current consumed by all the lamps, etc., in amperes will not be more than one-eighth of the battery capacity. This is true for the reason that the dynamo output at ordinary speeds must equal the current used by all the lamps and other devices and this output must not be more than one-eighth battery capacity.

FIELD WINDINGS.

The field magnets of a dynamo may be permanent magnets or they may be electro-magnets. If they are permanent magnets there is no coil or winding required to make them magnetic and the current is taken from the brushes to the work of lighting the lamps,

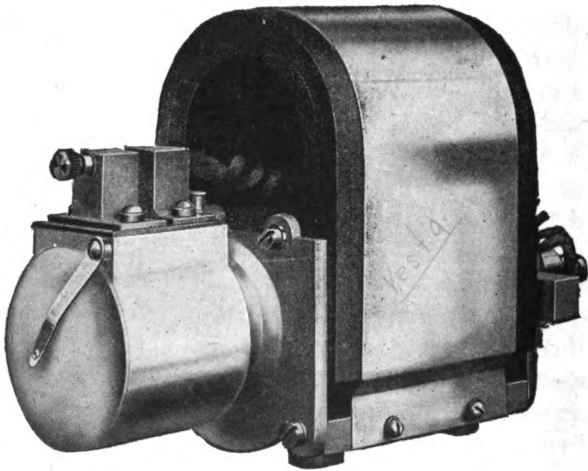

PERMANENT MAGNET DYNAMO.

Centrifugal cut-out is located in the cylindrical case at the left hand end.

etc., without any of the current being used for magnetizing the fields.

Most dynamos in use for lighting and starting systems have their fields made from electro-magnets having coils of wire around the soft iron magnet core, the

passage of electric current through these coils making the iron into a magnet. The current for these magnetizing coils is received from the dynamo itself by taking a part of the current generated and using it for this purpose.

It might be said that the soft iron of the fields would give no flow of magnetic lines of force through the armature to begin with if soft iron does not remain a magnet. This would prevent the dynamo from starting to generate current and of course there would be no current made to use for magnetizing the field coils. It should be understood, however, that no piece of iron, however soft, ever loses all its magnetism under ordinary conditions. There is a very small amount of magnetism left in the field cores at all times and this magnetism causes enough lines of force to flow through the armature coils to start the generation of more current, this current then strengthens the field magnets and the output of the dynamo rapidly builds up to normal. In actual practice this building up only requires a few seconds.

Series Winding. It will be understood that the coil of wire around the iron core of the field magnets has two ends. It will also be understood that there must be a positive and a negative wire leading from the dynamo to the outside battery charging and lighting circuits.

We might run one wire directly from the positive brush to the work and another wire directly from the negative brush to the work just as is done with permanent magnet machines. This would not leave any way of taking care of the field windings.

In order to magnetize the fields we will run the cur-

rent from the brushes through the field windings. To do this we will run the wire from one brush (either positive or negative) directly to the work.

From the other brush, however, we will run the wire to one end of the field coil and from the other end of the field coil we will run another wire to the work. It will thus be seen that all the current coming from this last brush must pass around the field-coil winding before going to the work: After the current goes to the work of battery charging or lamp lighting it returns directly to the other brush without passing through the field winding, inasmuch as the other brush was connected directly to the work. This method of supplying current to pass around the field coils is called series winding and the machine is said to be a series-wound dynamo or motor.

Shunt Winding. Consider the dynamo with its field coils again, but without any wires from the brushes to the field or to the work.

This time we will run a wire from each brush directly to the work without having either of them connected to the field coil.

The field coil in this case will be made from a great many turns of very small wire so that its resistance will be much higher than the resistance of the outside circuits to the work.

We will then run a wire from one brush to one end of this fine field winding and another wire from the other brush to the other end of the field coil.

When the current comes from the armature windings into the brushes the greater part of it will take the path of least resistance, that is, it will go from the

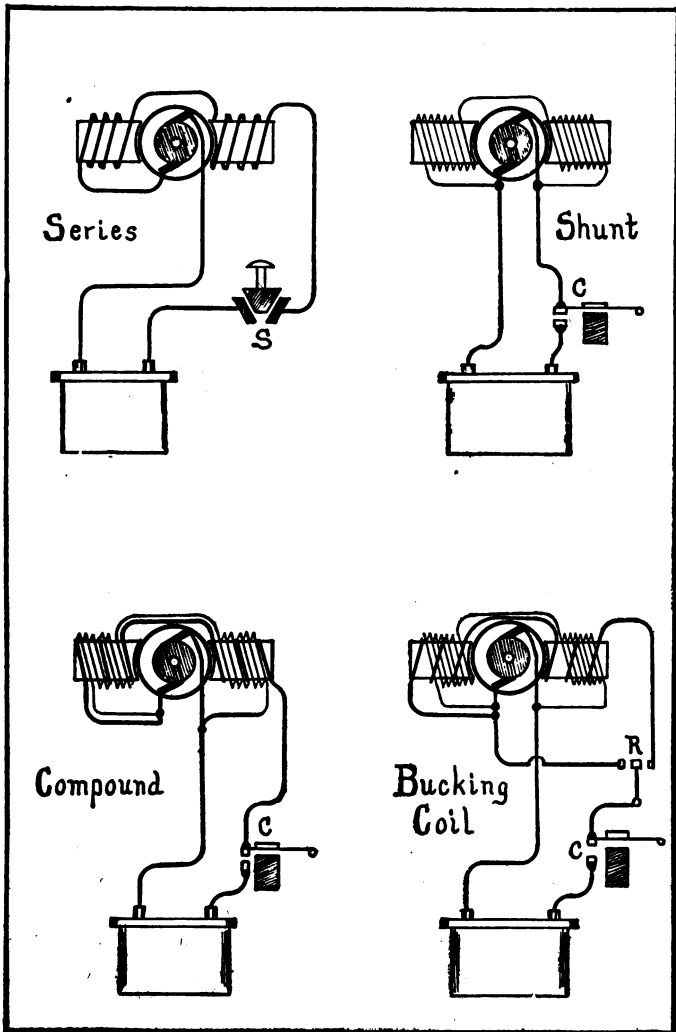

FIELD WINDINGS.

C, Cut-out; R, Regulator causing action or idleness of bucking coil; S, Starting switch.

brush into the wire that leads to the work. A small part of the current, however, will pass into the wire that leads to the field coil and will pass around the field coil and will then return to the other brush from the other end of the field coil.

The amount of current passing through the field will all depend on how many times greater the resistance of the field coil is than the resistance of the outside working circuits. The coil is usually made of such size and length that one-twentieth of the total current from the brushes goes through the field coil, the balance going to the work. This type of winding is called shunt and the machine is called a shunt wound dynamo or motor.

Compound Winding. Should we take a shunt wound dynamo and place a series winding around the field magnets in addition to the shunt winding already there it would form a compound winding and the machine would be called a compound wound dynamo or motor.

It was explained that when a current passes around a magnet in a clockwise direction the end of the magnet you are looking at will be negative and the other end positive. In a compound wound dynamo both series and shunt coils must be wound in such a way that both windings make a positive pole at one end of the magnet and a negative pole at the other end.

Differential or Bucking Coil Winding. Should we take a shunt wound machine and place a series winding around the field magnets in such a way that the shunt would make one end of the magnet positive while the series winding tried to make the same end negative we would have a differentially wound ma-

chine and the series winding would be called a bucking coil.

If the ampere turns of the shunt winding were greater than the ampere turns of the series then the shunt winding would cause the poles of the magnet to become positive and negative according to the direction of flow around the shunt coils.

The stronger the series coils then became the more their effect would tend to overcome the effect of the shunt coils and the magnet would become weaker and weaker as the force of the bucking coil became stronger and stronger. When both coils were of the same strength in ampere turns the magnet would be dead and would have no power or magnetic field. Should the series coil then become stronger than the shunt the magnet would again become stronger but the pole that was positive would be negative and the one that was negative would be positive and the brushes and outside wires would also change their polarity.

Characteristics and Uses of Windings. Each method of field winding as well as permanent field magnets have their peculiar points and are suitable for certain work. In some cases permanent field magnets also have a field coil wound on them. This arrangement and the differential winding are used for purposes of regulation.

In the series winding it will be seen that the less current goes to the work the less will pass around the field magnets and the weaker they will become.

It is a law of electricity that the stronger the field magnets are in a dynamo the greater the output of that dynamo will be in amperes, and the weaker the

field magnets are the less will the amperage of the dynamo become.

It is also a law of electricity that the greater the resistance of a circuit or conductor the less current will flow through it provided the voltage remains the same.

In a series wound dynamo having more work (more battery resistance) in the outside circuit the flow through the circuit will be less because more work means more resistance and more resistance means less flow.

If there is less flow through the outside lines there will be less flow around the field coils because the current to the work all passes around the field coils.

If there is less current flowing around the fields the field magnets will be weaker and the output of the dynamo will become less just when we need a greater output to take care of the extra work.

This makes series winding unsuitable for use in dynamos but the series winding is used for motors, producing the best type of motor for starting an engine.

When a series wound machine is used as a motor all the current received from the battery to be turned into mechanical power by the motor passes around the field winding on its way to one of the brushes.

The harder the work to be done by the motor the greater will be the flow of current required.

The greater the flow of current to the motor and through the fields the stronger the field magnets become and this increases the strength or pull of the motor in proportion to the current flowing.

It will be seen that a series wound motor is stronger the harder the work it has to do so that it is very well suited to starting the automobile engine.

It will be remembered that the battery maintains the voltage at a constant point at all times. It was also explained that it is the voltage or pressure of a current that forces it to flow through conductors.

The windings of a shunt wound dynamo are so high in resistance that they take but a very little of the current generated, but, just as long as the voltage remains the same (as it always does) this small amount of current will pass through the shunt winding. Whenever a generator runs at all it makes at least one-twentieth of its normal output and this is enough for the shunt windings. Therefore, the flow of current around a shunt field will remain practically the same no matter what the outside conditions.

As long as the flow remains the same the strength of the field magnets will remain the same and this steady field strength will cause the dynamo to give a fairly steady output regardless of the conditions under which it may be working. This makes the shunt winding very suitable for dynamos.

A shunt winding is not well suited for motors because the resistance of the shunt field is so high that it cannot increase its strength to take care of extra work as the series wound motor can.

Combining the two windings in a compound wound machine makes it well suited for work either as a dynamo or motor. The shunt winding prevents the output from dropping when there is extra work for the dynamo and the additional flow through the series winding required by the extra work strengthens the field and the output to a certain extent.

When a compound wound machine is used for a combined dynamo and starting motor, arrangements

are sometimes made so that only the series winding is used while the machine acts as a motor by having two separate commutators, one for each field winding.

Special means are provided so that the balance of

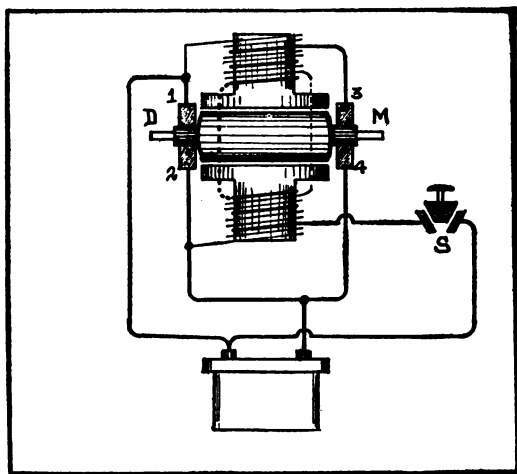

COMPOUND WOUND DYNAMO AND MOTOR.

D, Dynamo commutator with shunt field winding attached to brushes 1 and 2, giving ordinary shunt wound dynamo action in generating; M, Starting motor commutator, current passing through starting switch (S) to brushes 3 and 4, exciting series field windings only.

power between the shunt and the bucking coil in a differential machine may be changed in such a way that the output of the dynamo is kept at the rate desired.

ADJUSTMENT, OPERATION, CARE AND RE-PAIR OF THE PARTS OF DYNAMOS AND MOTORS.

Mounting. Dynamos and motors are usually mounted rigidly on the engine crank case or on the frame that carries the engine. If on the transmission case or frame of the car special care must be used that the mounting is strong enough so that the shaft is held in line with the gears or sprockets while under the strain of generating current or starting the engine.

Some types of dynamos may safely be mounted on iron bases without having the lines of force pass through the iron base. If an electric machine is encased with iron it will of course be safe to carry it on an iron base. If the magnets are apparently of the horseshoe, circular or U shape it will not be best to mount them in such a way that the ends of the magnets come close to a piece of iron that extends from pole to pole. While mounting this type of machine on an iron base may not affect the efficiency it can do no good and may do harm. In any case a base mounting of brass, aluminum or some other metal than iron or steel will be most satisfactory.

Dirt and Moisture. While modern dynamos and motors are made practically dirt and waterproof it is best to give them ordinary care to prevent either moisture or dust collecting on or near the case.

Moisture in a thin film will form a fairly good electrical conductor and might easily provide a path for the leakage of current under some conditions.

Dust or dirt of any kind may be a conductor itself and even if not a conductor, collects water and oil which are sufficient to make a leakage of current.

Fine dust from the brushes and commutator will collect inside the case and may easily form a conducting path if deposited on the brush holders, the insulation or other exposed parts carrying current. In addition to this trouble, dust will work into the bearings in time and cause a more rapid wear than normal.

The dynamo or motor should be opened and thoroughly wiped out with a clean cloth once every six months or even oftener in the case of the dynamo.

Assembling and Disassembling. In taking a motor or dynamo apart great care must be used that all outside wires and connections are first removed before the machine is loosened from its base and driving parts.

When opening the case or removing any of the covering plates they must be drawn away from the machine carefully and in a line straight out from the case because these covers often carry delicate electrical contacts, springs, brushes and other parts which are liable to damage.

Before attempting to remove the brushes the pig tails must be loosened from their terminals and the brush springs must be carefully removed or set to one side of the brush so that the spring will not be bent or broken in removing. If the spring adjustment is loosened when removing the brushes this adjustment must be made right again as directed below. When the brushes are withdrawn from the holders or when the holders and brushes are taken off together care

must be used that they are marked in such a way that the same brush will be replaced in the same place and that the same side of the brush will be toward the front of the armature as was the case before removing. Brushes wear to a good fit in the position in which they are originally mounted and they will not fit if replaced in any other position.

After the brushes and brush holders are removed the armature may be taken out of the armature tunnel by taking off one or both of the end bearings of the armature shaft. These are usually annular ball bearings held in housings or cases fastened to the outside of the dynamo or motor case with small screws or bolts.

The fields and field windings should usually be left in the case except in case of severe damage or breakage. The ends of the field windings must be carefully loosened from everything and withdrawn from any holes through which they pass so that the loose ends can be traced right up to the point at which they enter the field coil. The coil itself will remain on the core of the field magnet. These cores are screwed or bolted into the case and they must positively be replaced so that they occupy exactly the same position and stand the same way in the case when they are replaced.

Needless to say, the connections and terminals must all be marked so that they may be connected in the same way as originally found.

Terminal and Joint Care. The ends of all wires in the dynamo or motor as well as at all other points in the system should have copper or brass terminals attached and soldered to them so that the hole in the

terminal and not the wire itself may be placed over the binding screw.

When the terminals of wires are fastened to the binding screws the nuts or screws must be screwed down tight and fastened in place whenever possible. Before fastening terminals see that all surfaces in contact are bright and clean and free from all dirt and oil.

Simply twisting the ends of two wires together does not make an electrical joint of low enough resistance to be allowed in electric lighting and starting work. The wires must be thoroughly scraped and cleaned, twisted together tightly and soldered. The joint must then be covered with a winding of rubber tape and this covered with a winding of several layers of ordinary friction tape.

Armature Windings. The winding of coils on armatures and fields is a trade in itself and should never be attempted in the ordinary shop, for failure is almost sure to be the result.

Should a test at the dynamo terminals while the dynamo is running show that no current is being generated it may be possible that the windings of the armature are broken or burned or that they have become short circuited or grounded. The facts may be found by testing for broken circuits, shorts and grounds as directed under Lamps and Wiring. When one end of a test wire is held in contact with any commutator segment the test lamp or voltmeter should show a passage of current if the other test wire is held against any other commutator segment. If one segment is found which does not allow the flow of current the wire from this segment to its coil is broken

ELECTRIC LIGHTING AND STARTING 43

or burned off, the wire in the coil is broken or burned at some point or the wire of the coil or to the segment is short circuited or grounded to some other wire or coil or to the core or shaft. This will be true providing the trouble is not in the commutator or other parts outside of the armature windings.

If the broken wire is in plain sight it may be soldered as directed in this section, otherwise the armature must be removed and sent to the maker or to some electrical repair company having facilities for this class of work.

It may also be possible that the insulation may be worn or scraped from some part of the wire or winding in which case it may be replaced with friction tape.

Armature Core, Shaft and Bearings. Nothing will happen to the armature core except through an accident that makes the entire machine worthless.

The armature shaft might become bent, allowing the core to touch the pole pieces. It should be removed from the machine and straightened cold if only slightly bent near the end, but otherwise the armature must be sent to the maker for a new shaft.

The bearings require the care and adjustment that any other bearings of the same type require; all of which is given in the section on Car Parts.

Commutator. Should the commutator not receive proper care its surface will become rough, pitted and scratched. In this condition it causes rapid wear of the brushes, excessive sparking at the brush contacts and an irregular output and loss of current produced.

The surface of a commutator should be a dark brown or dark copper color and should be covered with a high

polish and glazed look. This would be the best possible condition. If the surface shows a bright fresh copper color the brushes are cutting and they should be examined for hard or sharp spots or possibly the brushes were not secured from the maker and are not suited for the machine.

To place a damaged commutator in good condition first examine it carefully to make sure that the surface is perfectly round. See that there are neither high or low segments or places on the segments, also see that the insulation is good between the segments and that this insulation does not stick up above the surface at any point. Then look to see that there are no particles of copper on the insulation so that they extend from one segment to the next. If there are particles of this kind remove them with a pocket knife blade. This precaution should be taken both before and after caring for the commutator.

Should there be noticeable high or low spots or should insulation project above the surface remove the armature and commutator and place in the lathe and take a very fine cut across the face of the commutator to make it perfectly round.

If the surface is scratched or pitted or rough, but still round, remove the brushes from contact with the commutator (if in the dynamo) or (if in the motor) remove the armature and commutator and place in the lathe. The dynamo may be rotated by starting the engine.

Now take a strip of number 00 sandpaper (not emery cloth or anything else) almost as wide as the commutator and wrap it over the end of a piece of wood so that it may be held against the surface of the com-

mutator. With the commutator rotating hold the sandpaper against the surface with slight pressure, moving the sandpaper so that it cleans and dresses all parts of the width of the commutator. Continue this operation until all marks are removed and the commutator is left clean and bright.

Next wipe the surface of the commutator with a clean cloth and then hold a piece of soft pine against the rotating surface until the commutator is polished and slightly darker in color.

After finishing the above blow or wipe all the dust from the case and parts where it has settled. Use a short length of copper tubing to blow through and after all the parts are clean the brushes may be replaced provided they are in proper condition for use.

Brushes. The material, pressure, position, shape and size of the brushes must all be suited one to the other. Except in case of absolute necessity no brushes should be placed in any dynamo or motor that are not furnished or recommended by the maker of the machine. The wrong brush will cause excessive sparking, heating, lowering of the output and a discharged battery and will wear rapidly and in doing so will damage the commutator.

The contact surfaces of copper brushes should be clean and smooth and bright, the contact surfaces of carbon brushes should be clean and smooth and slightly polished and should be a dark gray color.

The contact surfaces of any brush should fit the curve of the commutator at all points.

If the brush surface is rough or pitted or burned it may be restored to condition as follows: Take a piece of 00 sandpaper of a width slightly greater than the

width of the brush. Pass this strip of sandpaper down between the brush and the commutator so that the sand side touches the contact surface of the brush. Draw the strip back and forth, holding it so that it follows around the curve of the commutator. This will dress the brush surface so that it just fits the curve of the commutator.

After finishing all dust must be wiped or blown away from the parts.

Brush Holders and Insulation. The brush holder is usually made of metal and the brush itself is arranged in an insulating cover of mica, stone or fibre which is carried by the brush holder. The brush may become grounded to the holder through a cracked or broken insulation or from deposits of dust and dirt. In some machines the brush slides through the insulation while the holder remains stationary. In other machines the holder is carried on a pivot or hinge so that the holder and brush swing toward or away from the commutator. A possible source of trouble will be that the brush becomes stuck or wedged, or the holder may not swing easily on its pivot. In either case the brush cannot make proper contact with the commutator, lowering the output and causing sparking at the contacts.

Brush Springs. The strength of each brush spring must be the same as each of the other springs in the same machine. This pressure on the brush should be only enough in any case to prevent sparking and to cause the dynamo to give its normal output. Too much brush pressure causes rapid wear of both brush and commutator.

The tension of the springs may be tested by taking

a light spring balance or scale and attaching its hook to the brush spring or to the brush or the brush holder. Now pull on the balance until the brush just leaves contact with the commutator. The pull shown on the scale should be the same for all the brushes and if not the same, the springs must be adjusted.

Brush springs must hold the brushes in steady contact with the commutator and to do this they must not be bent or broken or sticking.

Field Windings and Cores. The same things apply to the field windings that were mentioned in connection with the armature windings. In the case of the field windings the tests must be continued from the point at which the wire enters the field coil to the point at which it attaches to the brush or leaves the case.

Providing the field cores are securely attached to the case and are in the right position they can give no trouble.

Drive. The drive from the engine to the dynamo or from the motor to the engine may be through gears or chains. Some of the old dynamos were driven by belts or by friction wheels running on the flywheel.

Should the armature shaft of the dynamo fail to turn with the engine running, the trouble will be in the driving parts. It takes the form of keys broken or sheared off; of broken shafts; loose or broken gears, gear teeth or sprockets, or broken chains.

The gears and chains are repaired and should have the care outlined for the various types under the headings in the section on Car Parts.

With belt or friction drive it is only necessary that

the parts be kept clean and dry and tight enough to do the driving.

Overrunning Clutches. In order that the rather small starting motor may have power enough to start the engine it is necessary to increase its leverage by some system of reduction gearing so that the starting motor may run at a greater speed than the crank shaft turns in starting. This reduction usually causes the starting motor to run at a speed of five to fifty times

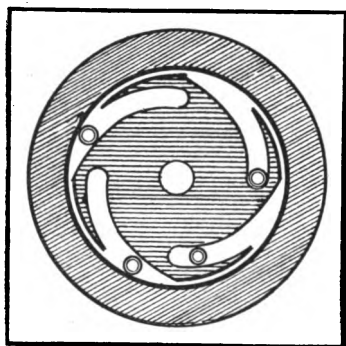

OVER-RUNNING CLUTCH.

that of the crank shaft. There are some systems however that use a starting motor so large that it takes the place of the flywheel and of course turns at the same speed as the crank shaft.

In case the reduction is fifty to one it will be necessary that the starting motor armature turn fifty times as fast as the engine crank shaft. Inasmuch as the engine will start easily when turned at 100 revolutions a minute this only requires a speed of 5,000 turns a minute of the starting motor which is not excessive.

As soon as the gasoline engine begins to operate its speed may go up to 1,000 revolutions per minute, which would cause the starting motor to turn at the rate of 50,000 turns a minute. An armature could not be built to stand this speed, therefore it is necessary that the starting motor be quickly and automatically disconnected from the engine or the gear reduction would cause it to run at excessive speed.

In order to do this a device called an overrunning clutch is used which is exactly similar in construction and operation to the coaster brake on a bicycle.

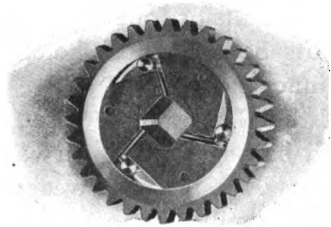

OVERRUNNING CLUTCH, ROLLER TYPE.

The part attached to the engine corresponds to the part attached to the road wheel of the bicycle and the part attached to the starting motor corresponds to the part that is attached to the driving sprocket of the bicycle.

Everyone knows that the rider can pedal a bicycle and apply power to the road wheel just as long as his feet will stay on the pedals, but should the bicycle go faster than he can pedal the road wheel can still increase its speed while the rider stops pedaling if he desires to.

The overrunning clutch drives the engine from the starting motor until the engine speed becomes more than the starting motor will turn. At this time the clutch releases and the engine can speed up while the starting motor can stop.

Overrunning clutches are made from two circular parts, one fitting inside the other. The one part attaches to the starting motor and the other part to the engine. Holes or slots are cut in the inner part that carry balls or rollers. When either part is caused to whirl by the starting motor, the balls or rollers fly out and wedge between the two parts, driving them both as one piece. Should one part now go faster than the other, the balls or rollers are forced back into the holes or slots because these holes are cut at an angle into the inner part.

The parts of the clutch are enclosed in a case and this case should be kept filled with vaseline or light transmission grease. Aside from wear in long service or breakage nothing will happen to prevent the clutch operating properly.

Small springs are placed back of the balls or rollers and should these springs break or should the balls or rollers stick the clutch will not take hold. Unless from long running without oiling the clutch will rarely refuse to release because the power to run the starting motor at such a speed would be so great that the parts would surely be separated under all ordinary conditions.

Should the starting motor turn without moving the engine trouble may be looked for in this clutch, usually through wrong assembling of the clutch parts.

ELECTRIC LIGHTING AND WIRING.

Circuits. When current leaves one of the terminals of a dynamo or battery it must be able to travel over the lines of the working circuit and return to the other terminal of the dynamo or battery. Unless the current can return in this way there will be no flow in any part of the circuit or wires.

After this current returns to the dynamo it passes into the brushes, through the armature windings to the other brush and to the other terminal where it again leaves the dynamo. The dynamo simply acts as a pump, sending the current round and round the circuit just as long as the wires have a complete connection from the positive terminal back to the negative terminal.

When the current returns to the battery it enters and passes from one of the plates to the other and then out of the other terminal and circulates the same as the dynamo current.

One of the very first things to look for in case of trouble would be loose or broken wires or connections because these stop the flow in the entire circuit. Unless the current can get back to the negative side of the source it will never leave the positive, so it makes no difference where the broken wire or connection may be, it stops the action in all other parts, either side of the break.

More electrical trouble in both lighting and ignition is caused by incomplete circuits than by any other

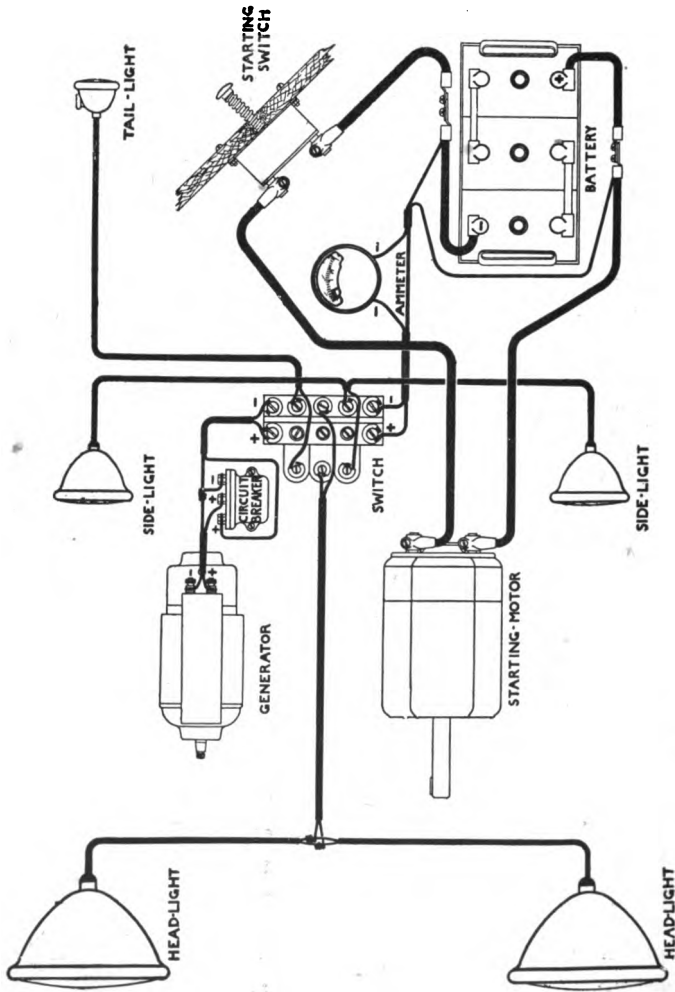

WIRING DIAGRAM OF COMPLETE STARTING AND LIGHTING OUTFIT. (Autolite.)

one thing. The user persists in running a wire correctly to one or more points and then leaving it without giving a return to the place from where it started. Unless you are able to trace a complete circuit from the dynamo or battery through the work and back to the dynamo or battery you are wasting time trying to make the parts operate.

Lamps. The lamp bulbs used in car lighting are classified according to their candlepower, the size of

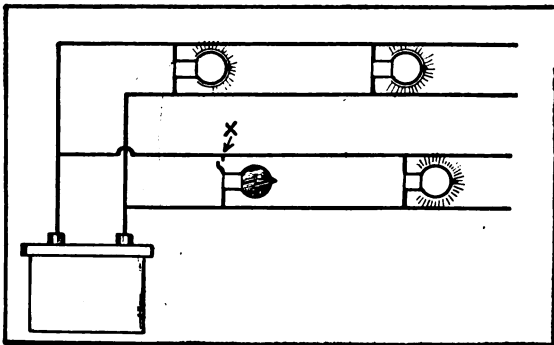

A BROKEN LAMP CONNECTION MAY AFFECT ONLY ONE LAMP IN MULTIPLE WIRING.

the glass bulb, the material of the filament inside the bulb and the type or method of fastening into the socket.

Bulbs may be bought having any candlepower from 1 to 30. In ordinary use 2 to 20 candlepower is about all that is required. As a general rule, head light bulbs have a candlepower of 15 to 24. Side lamps have 2 to 8 candlepower, tail and rear lamps use 2 to 4 and dome, dash, speedometer, trouble and similar small lamps require about 2 or 3 candlepower.

Lamp bulbs are usually marked with the candlepower they are designed to give, this marking being either on the glass of the bulb or on the metal that holds the glass. In addition to the candlepower marking the number of volts that the bulb should operate on is also marked at the same place. A marking of "6v-10cp" would indicate that the lamp would give 10 candlepower when operated on a 6 volt circuit. "4cp-8v" would indicate that the lamp would give 4 candlepower when operated on an eight volt circuit.

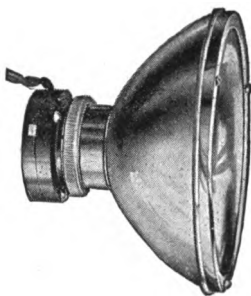

ELECTRIC SIDE LAMP.

Bulbs of higher candlepower should not be used to replace those burned out or broken. The system was designed to carry the load of the lamps furnished and placing higher candlepower bulbs in the circuits places a greater load on the parts than they were made to carry. An increase of two or three candlepower at one place on the car may be allowable but a general increase above this amount should not be attempted.

Bulbs for car lighting are made in a great many sizes. There are four standard sizes measured by the

distance through the bulb from side to side, or the diameter, in inches. The largest size bulb measures $2 \frac{1}{16}$ inches diameter, the next smaller $1 \frac{1}{2}$ inches, next to the smallest 1 inch and the smallest size $\frac{3}{4}$ inch in cross diameter.

The size of the bulb has nothing whatever to do with the candlepower of the bulbs. Neither has it anything to do with the voltage.

For instance, a 1 inch bulb may be secured in any

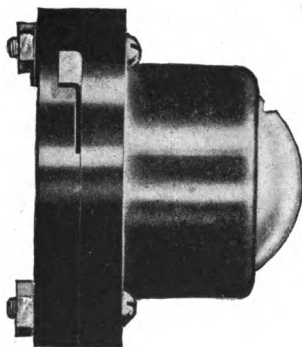

SMALL ELECTRIC LAMP USING DRY CELLS AS SOURCE
OF CURRENT.

standard candlepower and voltage. A $\frac{3}{4}$ inch bulb may have a greater candlepower than a $1 \frac{1}{2}$ inch bulb. The size of the bulb is decided according to the focusing of the lamp in its reflector and if the bulb size was $2 \frac{1}{16}$ no other size will do the work. In every case you must make the new lamp of the same size as the one broken or removed.

Inside of the glass bulb is placed a small wire through which the current passes, making it white hot

and producing the light. This wire or filament may be made of either one of three things. Some bulbs are made with the ordinary carbon filament such as is found in the older type of small house lighting lamps. These bulbs were first used altogether but later were partly replaced by bulbs having a tantalum filament. The tantalum was almost as strong as the carbon, gave a whiter light and produced nearly twice as much light with the same amount of current.

In modern practice the carbon and tantalum bulbs

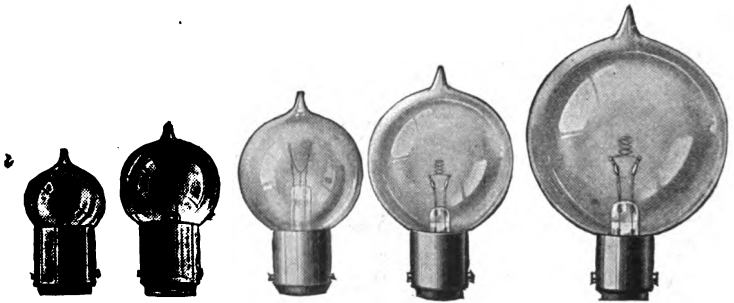

COMPARATIVE SIZES OF LAMP BULBS.
(One-half actual diameter.)

have been almost entirely replaced by tungsten filament bulbs, the tungsten filament being shorter and giving nearly three times the light of the carbon and not quite double the light of the tantalum bulb on the same amount of current.

Lamp Efficiency, Life and Voltage. The efficiency of a lamp is measured in the amount of power it consumes to make one candlepower of light. Electrical power is measured by watts, so the efficiency of a lamp is measured by the number of watts it takes to make one candlepower.

This depends to a certain extent on the age of the lamp and on its quality, but the greatest factor is the material of which the filament is made.

A carbon bulb requires from $2\frac{3}{4}$ to 3 watts per candlepower.

Tantalum requires from $1\frac{1}{2}$ to 2 watts per candlepower.

Tungsten bulbs of less than 10 candlepower usually take about $1\frac{1}{8}$ to $1\frac{1}{4}$ watts per candlepower.

Tungsten bulbs of 10 candlepower or more take about 1 to $1\frac{1}{8}$ watts for each candlepower.

It will thus be seen that the more expensive tungsten lamp is much cheaper to use for the light wanted.

Knowing the efficiency of a bulb we can easily find how many amperes of current it should take when operated at its correct voltage.

Supposing we want to find the amperes consumed by a 6 volt, 10 candlepower tungsten lamp.

Ten candlepower requires $1\frac{1}{8}$ watts per candlepower, making $11\frac{1}{4}$ watts for the 10 candlepower lamp.

We know that the watts equal the volts times the amperes so we know that $11\frac{1}{4}$ must equal 6 (volts) times the amperes used by the lamp.

Dividing $11\frac{1}{4}$ by 6 gives us $1\frac{7}{8}$, which would be the amperage required by one 10 c. p., 6 volt tungsten lamp.

If this lamp had been a carbon bulb we would multiply the candlepower (10) by the watts required per candlepower (3) giving us the watts required by the lamp (30). We then divide the watts by the volts (6), which gives the amperes used by the lamp, 5.

This method of finding the amperes may be applied

to any size or type of lamp or to any number of lamps on a car.

At present there are more 6 volt lamps in use than any other one voltage. There are also lamps that require 2, 3, $3\frac{1}{2}$, 4, 8, 10, 12, 16, 18, 20, 24 and 30 volts, all being in fairly common use. Lamps of $6\frac{1}{2}$ and 7 volts are used on six volt circuits for the reason that decreasing the voltage to a lamp increases its life. A six volt lamp on a six volt circuit will usually burn with its full candlepower from 100 to 300 hours. If the voltage is reduced to 5 or $5\frac{1}{2}$ the life of the lamp will be almost doubled although its candlepower will be greatly reduced.

The voltage of the current cannot be very easily reduced without changing the battery size but the lamps may be changed for ones that are supposed to take a higher voltage than the battery gives, thus securing the same effect of a lower voltage than the lamp was built for.

The higher the voltage of a lamp the easier it will be to break the filament, the filament in a high voltage being smaller to give the extra resistance required to act against the higher voltage.

The glass of the bulb is fastened into a metal base, this base being designed to fasten or screw into the socket in the lamp. There are three types of bases and sockets in use, the commonest one being the Ediswan or bayonet base. The metal carrying the bulb has two small pins sticking out about $1/16$ th inch on opposite sides of the base.

This base fits into a tubular socket, slots being cut down the sides of the socket for the small projecting pins to slide into. These slots are shaped like the cap-

ital letter J, the lower end of the slot being turned up. There are spring plungers inside the tubular socket against which the bottom of the bulb base presses. When the bulb is pressed into the socket and turned so that the pins catch in the turned part of the slot these plungers hold the bulb tightly in place and at the same time provide the electrical contacts for the bulb from the lighting lines. This type of base is used

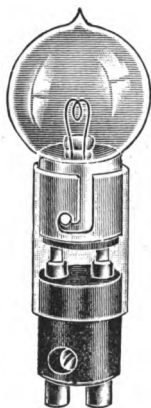

EDISWAN LAMP BASE.

almost altogether for car lighting. It is not suited for carrying more than five amperes because the connections heat.

The small bulbs having a screw base that threads into a screw socket are called candelabra bulbs. They are very little used on account of their liability to work loose. A still smaller size of screw base is called the miniature. This is used mostly for temporary decorative lights.

Lamp Connections. Lamps may be connected in multiple or parallel with the battery, this being the commonest type of connection. This means that a wire runs from the battery, carrying the positive current, and another wire runs close to the first one and carries the negative current. Lamps may be placed at any point along the length of these two wires, being fastened between the positive and negative sides. No mat-



TRouble-FINDING LAMP.

For temporary attachment to special terminals.

ter how many lamps are connected in multiple each one receives the full voltage of the battery.

For special purposes lamps are connected in series with the battery and with each other. The lamps in a series line divide the battery voltage equally between them. Thus, two lamps in series with a six-volt battery would each receive three volts; three lamps in series with a six-volt battery would each receive two volts; six lamps in series with a six-volt battery would each receive one volt, and so on.

Inasmuch as all the current passing through one part of a series circuit passes through all the other parts, the breaking of one lamp, or the removal or turning off of one lamp in a series circuit, puts out all the other lamps in that circuit.

This fact is made use of in car lighting by having the tail lamp and dash or speedometer lamp connected in series so that if the tail lamp goes out the dash lamp will also go out and warn the driver. These two lamps would be of half the battery voltage each but might be of different candlepower.

Any combination of multiple and series connections may be used to suit the work to be done. A series set of lamps may be connected between the positive and negative lines of a multiple circuit or several lamps may be inserted in a series line, these lamps being in multiple with each other.

Wiring Systems. Three systems of wiring are in use called the two-wire, single-wire and three-wire systems. The two-wire system is in common use and the single-wire system is also very popular. In a two-wire system a positive wire is run from the battery to any point on the car where current is to be used and a negative wire is also run from the battery to each of these points. This gives a complete wire circuit both from and to the battery and parts of the system.

The single-wire system has the positive wire leading from the battery to each of the parts to receive or use current. The other side or terminal of each part or lamp is connected by a short wire to the metal frame of the car. The negative side of the battery is also connected to the metal frame of the car so that the current returns from the parts or lamps to the negative side

of the battery through the metal frame of the car in place of through a wire. The single-wire system is provided with fuses in the wires from the battery to the parts and lamps. Should the wire become grounded the current will flow so fast that this fuse will burn out, preventing further loss of current and warning the driver or repairman of the trouble. The single-wire system saves about one-third the wire and allows better insulation of the wire that is used, because only one copper conductor is run inside the insulating cover in place of the positive and negative wires both being in the same cover, or near each other. There is thus less chance of leakage from positive to negative or short circuiting.

The side, dome and dash lamps of a car require double wiring anyway, being so far removed from the frame of the car. The double wire furnishes a connection without the necessity of making ground connections between the copper wire and steel frame, this connection being difficult to make so that it will not form high resistance with age and moisture. A two-wire system is not usually provided with fuses although this may be done. It should be remembered that several standard makes of magnetos will not allow the battery current to be grounded so that a separate battery would have to be used with a single-wire system on a car.

A three-wire system allows of burning lamps of two or more different voltages from the same battery while the lamps are connected in multiple with each other and the battery.

The commonest three-wire system makes use of a nine-cell, eighteen-volt storage battery divided into two

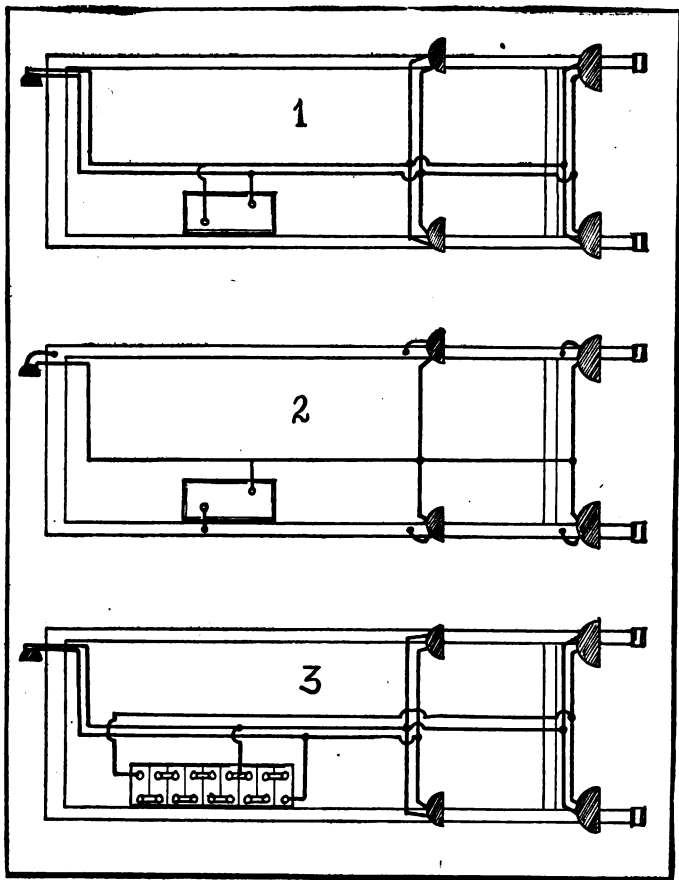

WIRING SYSTEMS.

1, Two wire system; 2, Single wire, grounded return system; 3, Three wire, six and twelve volt system.

sections, one of six cells and twelve volts, the other of three cells and six volts. The negative terminals of the two sections are joined together and a wire leads from this negative to the lamps taking either six or twelve volts.

Should it be desired to furnish twelve volts to any lamp it is only necessary to attach one side of the lamp to the negative wire, which is called the neutral or common wire, and the other side of the lamp to the positive terminal of the twelve-volt section of the battery. If another lamp is to receive six volts, one side may be connected to the negative wire and the other side to the positive terminal of the six-volt section of the battery.

Any size battery may be taken for a three-wire system and this battery may be divided into any size parts. The negative terminals of the sections are fastened together so that the neutral wire can be fastened to the joined terminals.

A battery used for a three-wire system is charged as one battery, no attention being paid to the sections.

The neutral wire of a three-wire battery may be grounded to the frame and two wires, each carrying different voltage, may be run to various parts of the car.

Fuses. Fuses are furnished in two forms for automobile use, one being in the form of wire, a piece of which is cut off and placed between two terminals at some point in the line. The other form is called a cartridge fuse and is made from wire placed in a small fibre tube having a copper cap on each end. This cartridge is about an inch long and five-sixteenths of an inch in diameter. The cartridge is fastened by being pushed into small spring clips that hold the copper

capped ends. When this style of fuse burns out it makes a small black spot on the fibre case near the center.

All fuses are rated according to the amperage they are intended to carry. Fuses should be able to carry about one-fifth more amperage than the normal requirements of the line in which they are placed. The fuse for the headlight lines should be about one-fifth more amperage capacity than the number of amperes the two headlights will draw as figured by their efficiency and watts or as measured by the ammeter. Should one of the wires become short circuited or grounded so that a greater flow of current passes



DISTRIBUTION PANEL AND SWITCH HOUSING.

through, the fuse will blow out or burn, preventing battery discharge.

The fuse between the battery and dynamo should be large enough to carry one-sixth of the battery capacity in ampere hours with lead batteries, or one-fourth with Edison batteries. There will seldom be a fuse in the starting system because the amperage is too high.

Fuses are usually found grouped together in a box having a screw cover, this box being near, or a part of, the lighting switch box, the distribution panel, or with the cut-out or regulator.

Never replace a fuse with a nail or wire. The result might be a discharged battery in time.

Wires and Protection. The wires for lighting are made from stranded flexible cable, or braided wire as it is often called. This copper is carried inside of insulation made of rubber, cotton and silk, and the whole is often enclosed in a braided or flexible metal covering for protection against chafing and breakage.

The ends of all wires are fitted with copper or brass terminals soldered, bolted or screwed to the end of the wire and having holes for screws or bolts so that they may be tightly fastened to the other parts, making a good contact.

Wires that are grounded or fastened to the frame must have the joint covered with solder so that the air cannot reach the joint between the steel and copper.

Switches. Switches are used for sending the battery current to the starting motor and to the lighting lines and lamps.

Starting switches are operated by a lever or pedal or button from the driver's hand or foot. They are built with very heavy contacts having a large amount of copper because they must carry an electric current of more than one horsepower in some cases. Starting switches often have two or more contacts, one being made after another by the further movement of the lever or button. In this case the first contact sends the current to the starting motor through a resistance wire so that only a small part of the full amount can pass to the motor. This causes the motor to start whirling with but little force while the gears are placed in mesh ready to start the engine. Further movement of the starting switch makes the full connection through an-

other contact, giving the starting motor the full power of the battery.

Lighting switches are of four common types: push button, rotary, snap and knife.

Push-button switches are made with two small buttons in reach of the driver. When one of these buttons is pushed in, contacts are closed in the switch, sending the current through to the lamps. When one button is

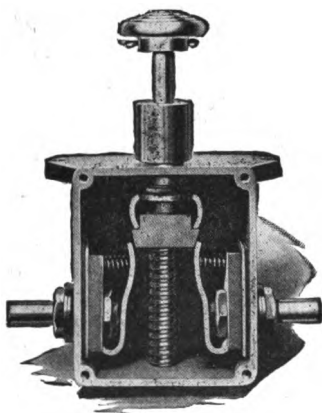

TYPICAL STARTING SWITCH.

pushed in the other one comes out and when the second button is pushed in the first one comes out and the contact is broken, cutting off the current. Another type having only one button is made, this button being pushed in or out to break or make contact. There must be one push-button switch for each lamp circuit to be controlled.

One type of rotary switch is composed of an arm extending out from the center and which turns around

the center, being operated by a handle or button on the outside of the switch cover. This arm is made from copper or brass and is connected to one side of the battery line, either positive or negative.

On the plate under this switch arm are arranged as many copper or brass rings as there are circuits to be taken care of, these rings being set one outside the other and all around the same center but insulated from each other. The arm makes contact with all the rings that are under it at any one time and, as the rings are connected through the lamps to the other side of the

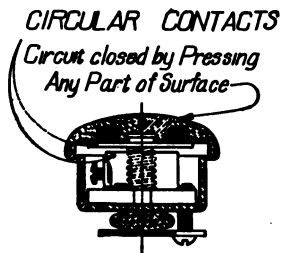

PUSH BUTTON SWITCH FOR USE ON DASH LAMPS OR HORN.

battery, the circuit is completed through the arm and ring and the lamps are lighted. In order that all the lamps may not be lighted at the same time and that they may all be turned off these rings do not extend all the way around the circle, all of them having a rather wide gap at one point, where the ring is covered by insulation, and all of these gaps being arranged to come under the switch arm at the same time. This position would turn off all the lamps. As the arm is turned to another position it will make contact with the rings but if it is desired not to have the lamps lighted on some one circuit the ring for this circuit is sunk away from under

this position of the arm. By sinking the rings at the proper points any combination of lamps may be lighted at will.

The knife switch is made with a thin piece of copper

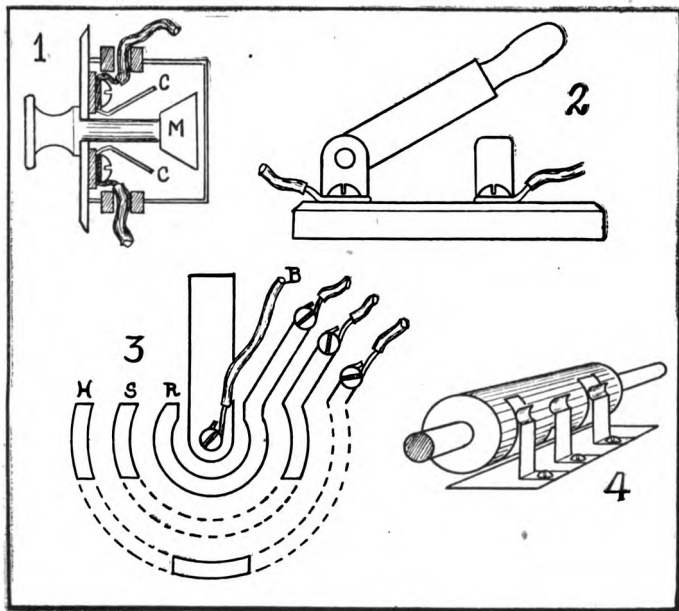

SWITCHES.

1, Push button switch, button pulled out closes contacts C-C through M; 2, Ordinary knife switch; 3, Rotary switch; B, Wire from battery; H, head light ring with wire to lamps; S, Side light ring; R, Tail lamp ring; 4, Rotary Switch using spring fingers in contact with segments set into insulating material.

that can be pressed between two clips, the other end of the copper being pivoted for turning.

The snap switch is the ordinary type of switch operated by a turning button that is found in house lighting systems. Neither knife nor snap switches are used to any extent in automobile work.

HOW TO MAKE TESTS FOR LOCATING TROUBLES IN CAR WIRING.

Tester. Every repairman should make a tester for use in locating electrical troubles.

To make this tester secure three or four dry cells, not necessarily new ones, and fasten them to a board that is about two or three inches longer than necessary to accommodate the cells. To the extension of this board fasten an ammeter, a voltmeter or an electric light socket. If the light socket is used place a bulb in it of the voltage of the number of dry cells used. Thus three dry cells would require a three-volt lamp. Now connect the cells in series, the positive terminal of one being connected to the negative terminal of the next one and so on. From the last unused terminal nearest the lamp or meter run a wire to one of the terminals of the lamp or meter. Then take two wires, each four feet long and insulated, and attach one of these wires to the remaining terminal of the lamp or meter and the other wire to the remaining terminal at the other end of the set of batteries. Cut the insulation from the free end of the two wires and bend these ends into loops and solder the loops so that the wire will not unravel. When these two loops are touched together the lamp will light or the meter will show a flow of current. If one end of one wire is touched to any wire or metallic conductor and the other loop is touched to the other end of the same wire or conductor the lamp will light or the meter show a flow provided

the conductor is not broken at any point between the two ends being touched. If one loop of the tester is touched to one end of a wire when the other end of that wire is grounded, the lamp should light or the meter show a flow when the other loop is touched to the metal of the ground.

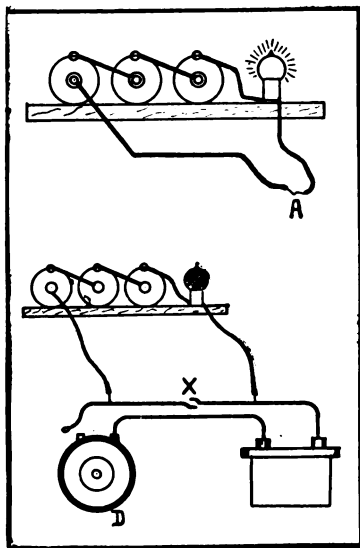

TESTER.

Connecting ends of wires (at A) causes lamp to light. Touching ends of tester wires to ends of defective wire indicates break (X) by lamp not burning.

Broken or Loose Wires or Broken Circuits may be located with the tester by removing one end of the suspected wire from the terminal it is attached to and then touching each end of the wire with one of the tester loops. If the lamp does not light the wire is broken or there are loose connections in its length.

It is absolutely necessary, in all tests, that the wire be removed from one end at the time of testing because if this is not done the current may return through another path. There will be cases where both ends of the wire need to be removed, as when grounds are to be located or when the wire divides into several parts.

Tracing Circuits. In case it is desired to know just where a certain wire leads to, remove the end that you know and recognize, and attach it to one of the tester loops. Take the other loop of the tester and touch it in succession to other wire ends on the car until the lamp lights; you will then be touching the other end of the wire wanted.

Locating Grounds, Short Circuits, Defective Insulation. Remove one end of the suspected wire from its terminal and attach it to the tester loop. Then touch the other loop to the metal of the car and of parts near which the wire runs, also touch it to all other wire terminals except the other end of the wire being tested. The lamp should not light under any of these conditions. If it does light examine the wire for the above troubles.

A ground occurs when a wire touches the frame or a metal part so that the current can return to the battery or to other wires or parts without going through the lamp or part that it should go through in order to do its work.

A short circuit, usually called a "short," occurs when one wire touches another wire so that current may return to the battery without going to the lamp or part that it should go to in order to perform its work. Shorts may come at the ends of wires or at places where the insulation has been cut or chafed away.

In a single-wire system having fuses, or in any fused system, the line in trouble may be located by placing a lamp (not the tester but a separate lamp) between the terminals or clips that carry the fuse. If the lamp lights that circuit is shorted or grounded.

Polarity of Wires and Reversed Connections. To find which of two wires carries positive or negative current place the bare ends in a glass of water in which has been dissolved a little salt or vinegar or any acid. The negative wire will bubble most.

It is usually important that the positive wire be connected to one terminal and the negative to another terminal of a unit, these terminals being marked positive and negative. These connections must not be reversed. Places where it makes no difference how the wires are connected include the lamps and lamp sockets, knife, snap and push-button switches, the starting switch and the starting motor.

The greatest care must be used to make sure that the positive wire from the dynamo is connected to the positive wire of the battery and the negative dynamo wire to the negative of the battery.

Connecting Ammeters and Voltmeters. Many systems have ammeters installed and many more have not. Very few systems have voltmeters installed. In some cases it is a convenience to have a voltmeter so that the pressure of the battery charging current may be known. An ammeter, while not a necessity, tells the repairman and operator so many things regarding the operation, correct or incorrect, that one is very desirable in any system and may often be installed by the repairman to the great advantage of the system and the peace of mind of the driver.

An ammeter may be mounted at any convenient point on the car. In using an ammeter for purposes of testing it is not necessary that it be solidly mounted at all; it may simply be laid anywhere while testing.

After locating the ammeter (which must be made with zero at the center of the scale and readings both ways), go to the negative battery terminal and follow this wire in its path to the starting motor or starting

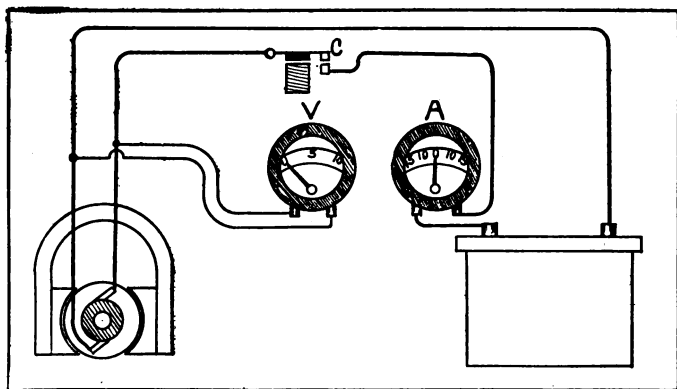

METER CONNECTIONS.

V, Voltmeter; A, Ammeter; C, Cut-out.

switch. At some point between the starting motor and switch and the storage battery there will be a smaller wire leading from the large one. This smaller wire goes to the dynamo and lamps. If there is no starting motor it will not be necessary to look for the branch wire, the negative wire being run direct to the dynamo and lamps. Now follow this smaller wire, starting from the battery end, until it branches into two or more parts and stop there. You can cut this

wire or break a connection at any point between the place where it leaves the starting circuit and the place where it branches. Cutting or breaking a connection will leave two free ends of wire. Now take a double wire or two wires and run one of them from one end of this break to one terminal of the ammeter and the other one from the other end of the break to the other ammeter terminal.

Then turn on the lights with the engine idle and watch the ammeter. If the hand moves toward the side marked D or discharge your connections are right. If the hand moves toward the side of the dial marked C or charge you must reverse the wires at the ammeter terminals which will make it give the correct reading. If the dial of the ammeter is not marked place a D on the side of the ammeter toward which the hand moves when the lamps are turned on and on the other side place a C, indicating discharge and charge of the battery.

If the connections are correct you can tape the joints made and fasten the wires to the car securely, finishing the job.

One side of a voltmeter must be connected to the wire coming from the positive terminal of the dynamo before this wire branches into two or more parts, the other voltmeter wire being connected to the negative terminal of the dynamo before its wire branches into two or more parts. This will cause the voltmeter to indicate the voltage of the dynamo when running but will prevent the battery current discharging through the voltmeter while the dynamo is idle because the cut-out is between the voltmeter connections and the battery.

Start the engine and watch the voltmeter hand and if no reading is secured the connections to the voltmeter terminals must be reversed.

Ammeter or voltmeter hands should stand at zero when the engine is idle and the lamps all off. If the hands do not stand at zero they may be adjusted by small screw or lever adjustments found around the outside of the case or by removing the front or back covers or plates.

STORAGE BATTERIES.

Action. A storage battery is a device for causing electric current to make certain chemical changes in metal plates and liquid contained in the battery jars. After the current makes this change the metal plates will cause a current of electricity to pass between them and this causes the plates to return to their original state. The battery may then be charged again by passing more current through it and so on.



SIX VOLT, THREE CELL STORAGE BATTERY HAVING
REMOVABLE COVER. (WITHERBEE.)

Construction. The ordinary batteries used in lighting and starting systems are known as lead batteries. The plates are made from a composition of lead and antimony formed into a network, this part being called the grid. The grid has an extension at the top toward one side so that the current may pass into and out of the plate.

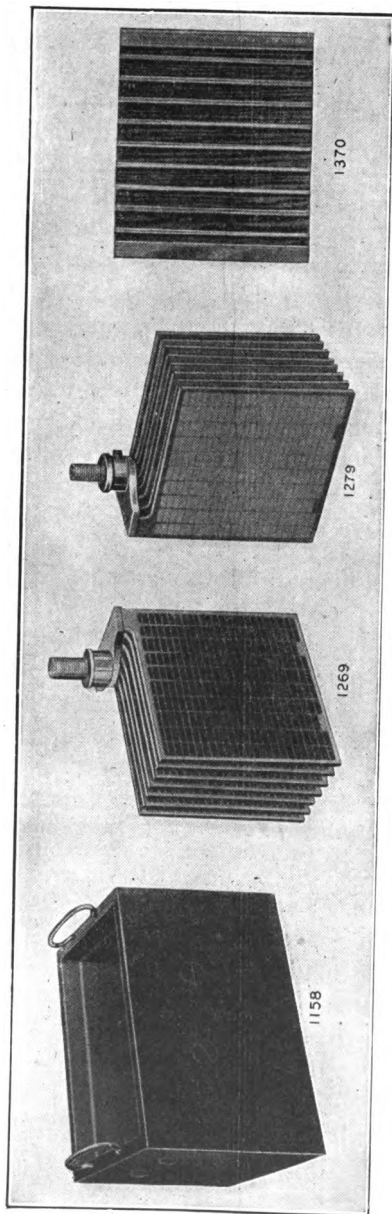

LEAD CELL UNITS.

1158, Wood battery case; 1269, Positive plate group; 1279, Negative plate group; 1370, Wood plate separator.

This grid is full of a paste made from a mixture of red lead and litharge moistened with water and sulphuric acid. This material is pasted into the grid and allowed to dry

A mixture is then made of one-fourth pure sulphuric acid and three-fourths distilled water, this electrolyte liquid being placed in a glass, rubber or other insulating jar. Several plates are then placed in the jar of

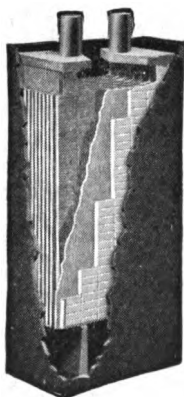

INTERIOR OF A STORAGE BATTERY.

Showing the plates and separators, the extensions on the top of the plates with the outside terminals and the space below the plates for sediment.

electrolyte and the alternate plates are connected together with the extension pieces at the top of each. This forms two sets of plates. There is always one more plate in one set than in the other set.

In the bottom of the jars are ridges on which the plates rest so that a space is provided in the bottom of the jar for the collection of material that loosens from the plates and falls down. The plates are prevented

from actually touching each other while in the jar by separators made from thin sheets of corrugated wood and thin sheets of hard rubber full of small holes. A cover is then placed over the top of the jar, this cover having a small hole in the center over each jar and this hole is closed by a screw plug having very small holes drilled through the plug. These plug holes allow the escape of gas while charging and discharging.

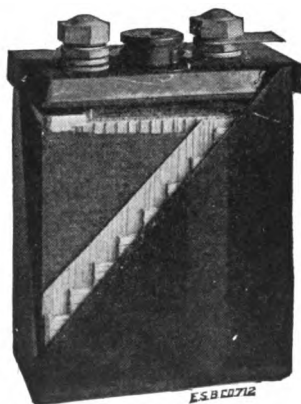

SECTION THROUGH LEAD STORAGE BATTERY CELL SHOWING ARRANGEMENT OF PLATES AND SEPARATORS.

The set of plates having the larger number is now connected to a wire carrying a negative direct current from a dynamo and the smaller set of plates is connected to a wire carrying positive direct current.

The current is then allowed to flow through the cell from thirty-six hours to ten days at a very low amperage.

This slow charge changes the plates so that the set connected to the positive wire become covered with

peroxide of lead and turns a dark brown color and the plates connected to the negative wire are covered with spongy lead in a metallic form and are a dark gray color.

The battery is then said to be charged and if the charging wires are removed and the terminals of the sets of plates connected by a wire there will be a flow of current between the plates and the battery will become discharged.

Types. Storage batteries are used for ignition, lighting or engine starting. A starting battery will give satisfactory service for either ignition or lighting; a lighting battery will serve as an ignition but not as a starting battery and an ignition battery can not be used for either lighting or starting.

Ignition service requires a flow from the battery of about one-half to one ampere and these batteries are made with a thick plate with hard material in the grid.

Lighting service requires about five to ten amperes and these batteries are made with thinner plates so that the action of the acid electrolyte may more easily reach into the material and give the higher discharge rate.

Starting batteries must give a discharge as high as 125 amperes and to do this the plates are made very thin and the material is made quite soft or porous, making it possible to get very rapid action in the cell.

The cranking ability of any system for starting the engine does not depend on the battery, it depends on the size and efficiency of the starting motor and its connections and gearing.

Capacity. The amount of current that a storage battery will hold is measured in ampere hours, this being

found by multiplying the ampere flow by the hours it takes to discharge the battery at that rate.

Regardless of how large or how small a lead storage cell may be it will deliver a voltage of $1\frac{3}{4}$ to $2\frac{1}{4}$, no more and no less. The normal voltage of a single cell is two, regardless of the number or size of the plates of cell.

When the cell is fully charged this voltage may rise to $2\frac{1}{4}$ and when the cell is discharged the voltage will fall to $1\frac{3}{4}$.

The ampere hour capacity of a cell however depends on its size, being governed by the cubic inches of material in the plates and the square inches of plate surface exposed to the action of the electrolyte, the greater the cubic inches and surface the greater being the capacity of that cell.

More current must be put into a cell than can be taken out. No cell could be 100 percent efficient any more than any other piece of machinery or device could have this efficiency. As a general rule from one-fifth to one-fourth more current must be passed into a storage battery than can be drawn out on the discharge.

The temperature has a great deal to do with the efficiency and output of a battery. A battery will do its best work at about 70 degrees Fahrenheit. At 110 degrees it will give 10 per cent more output than at 70 degrees and at 20 degrees below zero it will give less than one-third its normal output.

Electrolyte. As mentioned before the electrolyte or liquid in the cells is composed of one-fourth pure sulphuric acid and three-fourths distilled water. As the cell discharges, part of the acid seems to pass into the plates and the liquid then contains more water and

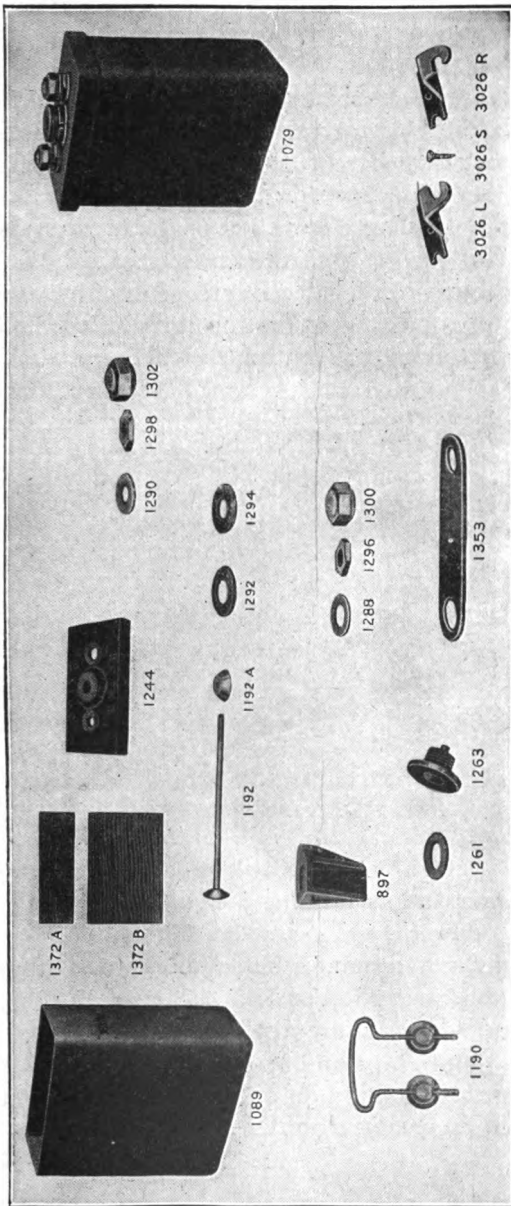

LEAD CELL PARTS.

897, Fixture for holding battery; 1079, Complete cell; 1089, Rubber cell jar; 1190, Battery handle; 1192, Through bolts for case; 1244, Cell cover; 1261, Gasket for plug; 1263, Filling plug; 1288, etc., Terminal nut and gaskets; 1290, etc., Terminal nut and gaskets; 1292, etc., Terminal gaskets; 1294, etc., Terminal gaskets; 1300, etc., Terminal gaskets; 1302, etc., Terminal gaskets; 1353, Cell separator; 1372 A-B, Wood separators; 3026, Battery box holders.

less acid. The acid is nearly twice as heavy as the water so that the electrolyte becomes lighter as the cell becomes discharged. From this fact it is possible to gain a very good idea of the amount of current left in the battery by finding the weight of the electrolyte.

The weight of the electrolyte is measured by floating a hydrometer in the electrolyte or by drawing some of the electrolyte out of the cell through the hole in the cover by means of a hydrometer syringe. This

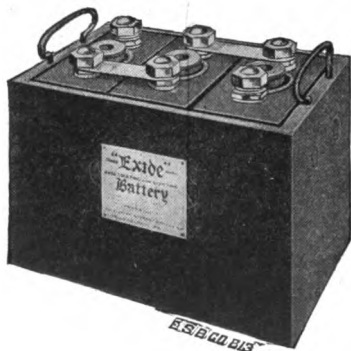

SIX VOLT STARTING AND LIGHTING BATTERY SHOWING TOP CONNECTIONS.

is a syringe with a rubber bulb at one end and a small tube at the other and containing a hydrometer in the syringe.

The stem of the hydrometer has numbers on it that run from 1,100 near the top to 1,350 near the bottom. The heavier the electrolyte is the higher the hydrometer will float and the number on the tube that is nearest the surface of the liquid indicates the weight or the specific gravity.

The battery may be tested at any time although the most reliable results are secured while it is being charged. Remove the plug from the top of the cell to be tested and stick the small tube of the hydrometer syringe down into the cell as far as it will go. Now squeeze the bulb and draw the electrolyte up into the syringe until the hydrometer floats in the liquid. Take the reading of the number nearest the surface and if this number is 1275 to 1325 the cell is fully charged. If it is 1200 it is half charged and if

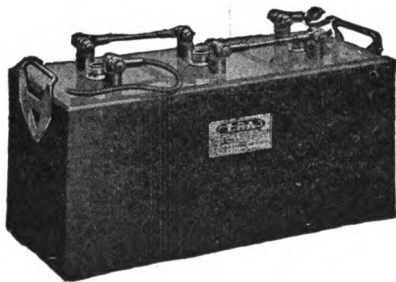

"LBA" LIGHTING AND STARTING BATTERY.

it is as low as 1150 the cell is discharged and should be charged before further use.

If the electrolyte is so low that the syringe will not draw it up, the cell must have distilled water added until the level of the electrolyte is three-eighths to one-half inch above the tops of the plates in the cell.

Except under special conditions nothing except pure distilled water should be added to the cells of a storage battery. The acid does not evaporate and should not need replacing. If more acid is added the voltage

of the cell is temporarily increased but the life of the battery is shortened greatly. The less acid used in

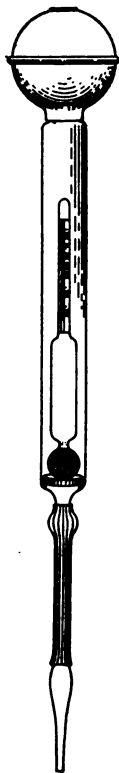

BATTERY TESTING HYDROMETER.

The hydrometer itself is shown inside of the tube of the syringe. At the top is the rubber bulb and below is the long tube for reaching into the storage battery cell.

a cell the longer the cell will last, but if the percentage of acid is too low the cell will give trouble through a

deposit forming on the surfaces of the plates which prevents its proper action.

Whenever the water gets low in the cells it must be replaced through the top filling plugs by more distilled water or melted artificial ice or clean rain water collected in a wood pail. No water must ever be used from the pipes or taps or faucets in a city water system nor must any water be used from a metal container or from a spring. It will be necessary to replace water lost by evaporation twice every month during cold weather and every week in hot weather. Fill each cell separately.

In case part of the electrolyte is lost through spilling or leakage it will be necessary to replace this loss with a mixture of pure water and pure sulphuric acid made strong enough to give a specific gravity test the same as the electrolyte in the next cell. In mixing the electrolyte always pour the acid into the water and then let the mixture cool before using in the cell. Pouring water into acid will result in the acid being thrown out of the dish and sulphuric acid burns hands, clothes and everything else it comes in contact with.

Should sulphuric acid or electrolyte be accidentally spilled on the hands or clothing apply a liberal quantity of strong ammonia immediately. The ammonia will neutralize the effects of the acid if applied soon enough.

The terminals of storage batteries must be kept clean and bright in order that they may make good electrical contacts. The acid acting on the copper or brass terminals causes a deposit of green verdigris which does not allow the passage of current. This may be removed by washing with a solution made by

dissolving as much baking soda in hot water as the water will take up. After washing again with clean, pure water, dry the parts and cover them with a layer of vaseline everywhere except the parts that make actual contact.

Battery Charging. In actual operation in the car the battery is being charged all the time that the engine is running and it is being discharged all the time the lamps are lighted or the starting motor working or any other current consuming devices are in operation. Thus the battery may apparently be charging and discharging at the same time.

The actual operation of the system is that the dynamo makes so much current, this current going either to the lamps or battery or part to each. When the lamps are off all the current goes to the battery but when the lamps are turned on part of it goes to the lamps. If the lamps require all the current being made then none of it goes to the battery and should still more lamps be turned on so that the dynamo is not making enough current for them some additional current will be drawn from the battery to help out. When the lamps are turned on with the engine idle the battery is being discharged only. Thus the battery acts as a kind of balance in the system between the dynamo and lamps, taking up any additional current not used and giving out extra current when needed.

The state of charge of the battery may be found by testing the specific gravity of the electrolyte and if this is found to be below 1150 the engine should be run with the lamps turned off either with the car idle or running. When the battery is fully charged the electrolyte begins to bubble, these bubbles being hydrogen gas.

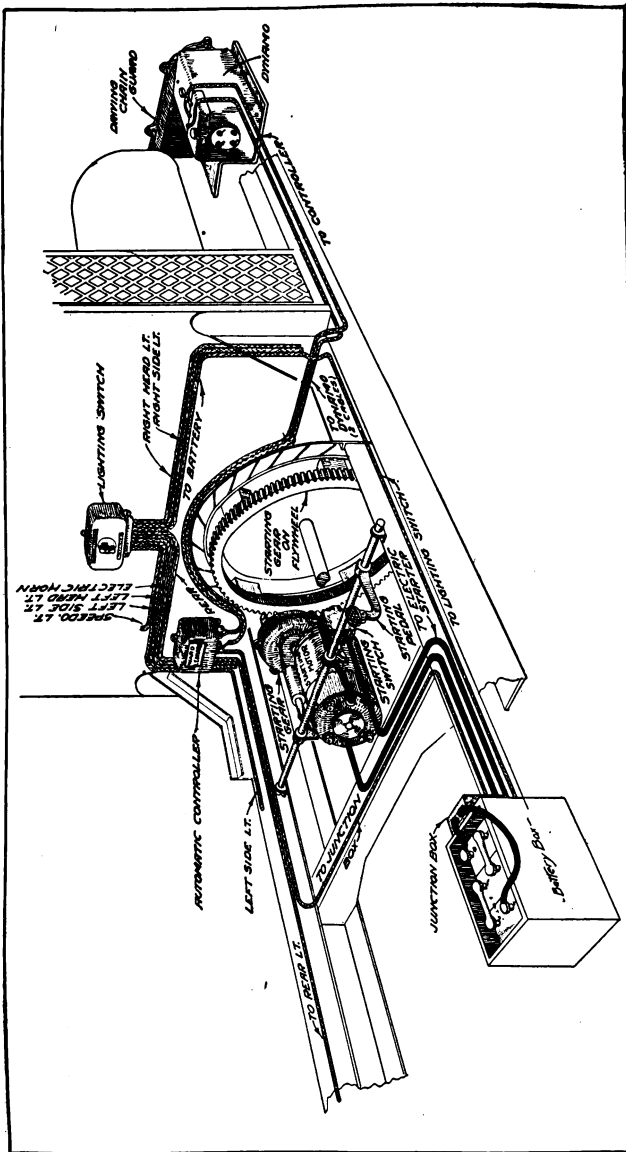

LOCATION OF UNITS IN A TYPICAL LIGHTING AND STARTING SYSTEM. (Ward Leonard.)

In order that a battery may be maintained in good condition its specific gravity should never fall below 1100 and should be kept above 1200 if possible. Every two weeks, whether the car be in use or laid up the engine should be run at a fair rate of speed until the specific gravity rises to at least 1275 and the cells give off gas. After the cells gas and the specific gravity does not rise any more continue to charge the battery by running the engine for one hour more.

If a lead storage battery is allowed to stand for any length of time while discharged the plates become covered with a thin coat of sulphate of lead and the battery is said to be sulphated. This coating is an insulation between the plates and makes it hard to either charge the battery or use it for lighting or starting. To cure sulphating the battery must be removed from the car and charged at a very low rate, two or three amperes, for three or four days. Should this treatment fail to restore the battery it may be replaced in the car with the connections reversed, that is, connect the positive dynamo wire to the negative battery terminal and the negative dynamo wire to the positive battery terminal. Now run the engine very slowly until the battery becomes completely discharged and the electrolyte tests nearly down to 1,000. The battery will then start to charge again but the terminal that was negative will then be positive and the positive terminal will be negative. Charge the battery in this direction until fully charged and then empty the old electrolyte out and replace with new liquid that tests 1275. Now change the connections back to the right way and recharge the battery to its proper gravity.

If the car is to be laid up the battery should be fully

charged by running the engine and then it should be recharged fully every two months while laid up. The better way is to remove the battery after it is fully charged and send it to a battery company for storage.

Should it be necessary to remove a storage battery from the car for charging it should be sent to a company making a business of battery charging.

If the battery must be charged in the shop it will first be necessary to have a supply of direct current or else make use of an alternating current line with a rectifier.

If there is direct current in the building run a wire from the negative wire of the main supply line direct to the negative pole of the battery. Now extend a wire from the positive supply line and another from the positive terminal of the battery but do not connect these wires directly. Between these two positive wires place electric house lamps with one side of the lamp connected to one wire and the other side of the lamp to the other wire. Use three 32 c.p. carbon bulbs or six 16 c.p. or 50 watt carbon lamps between these two lines. Any combination of lamps may be placed between the battery and line positive wires that will give a flow of about three amperes. This is a very wasteful and expensive method of charging, costing from two to four times as much as it would cost to have the battery charged by a battery charging house.

It is allowable to test the charge of a battery by using a voltmeter connected across the terminals for a few seconds. In doing this remember that each cell of the battery should give two or more volts; thus a three cell battery should give six to seven volts, a six cell battery from twelve to fourteen volts, etc.

Never connect an ammeter across the terminals of a battery under any conditions because the ammeter being of such low resistance will allow too great a flow, ruining the ammeter and possibly damaging the battery.

Never test a storage battery by touching the two

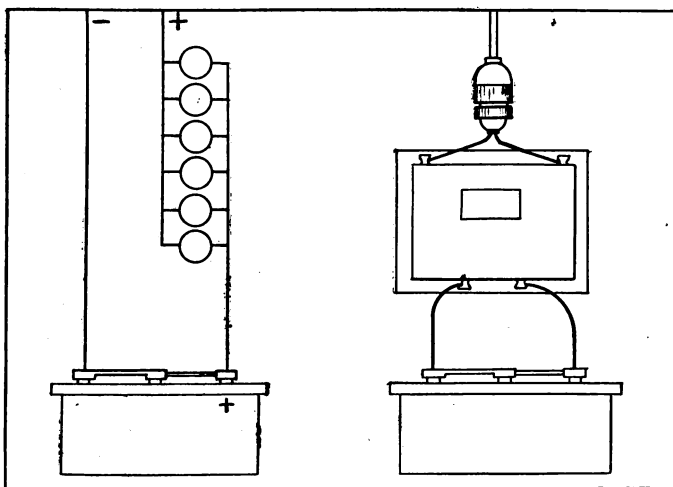

BATTERY CHARGING.
Through lamp resistance or through rectifier.

terminals with the pliers or any other piece of metal as this damages the battery every time it is done.

Gravity in one cell much lower than in the others, especially if successive readings show the difference to be increasing, indicates that the cell is not in good order.

If one cell regularly requires more water than the others, thus lowering the specific gravity, a leaky jar

is indicated. Even a slow leak will rob a cell of all its electrolyte in time, therefore the leaky jar should be immediately replaced.

If there is no leak and the gravity is, or becomes, fifty to seventy-five points below that in the other cells a partial short circuit or other trouble within the cell is indicated. This may be caused by an excessive collection of sediment in the bottom of the jars, by metallic impurities added with the water, by buckled loose or broken plates. In any case the battery requires the attention of a shop equipped for assembling and disassembling batteries.

A battery charge is complete when, with the charging current flowing at the finishing rate ($1/20$ th of the ampere hour capacity of the battery in amperes) all cells are bubbling freely and evenly and the specific gravity of all cells has shown no further rise during one hour. The gravity should test between 1.275 and 1.300.

The battery must be securely fastened in place in the car so that vibration and jar are avoided. The battery should rest on wood cleats and should have an air space all around it. The fastenings must take hold of the case or handles, not the terminals.

The battery compartment must be kept clean and dry and tools and other small metal articles must be kept away from the battery. The terminals and connections should be kept coated with vaseline.

Experience shows that about 90 per cent of storage battery trouble can be traced to one of two things: lack of filling with water and undercharging. Low level of the liquid causes ruined plates and excessive heating while charging. This is very harmful to the battery.

The commonest causes of undercharging are that the dynamo is not delivering sufficient amperage, there are loose wires or connections in the system or the dynamo commutator is in bad condition.

The commonest cause of discharged batteries next to the above is that the operator is extravagant in

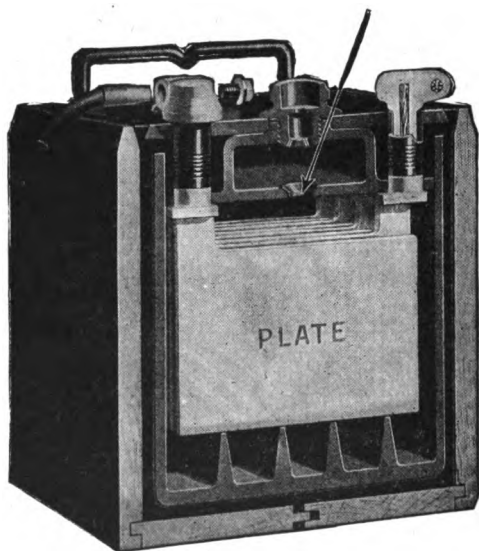

INTERIOR OF LEAD STORAGE BATTERY.

Showing the ridges on the bottom of the jar that form the sediment space. The arrow indicates the proper height of the liquid above the plates.

using the current through burning lights needlessly and forcing the starter to do its work with the carburetor improperly adjusted for easy starting.

The other ten percent of troubles comes from broken jars and from short circuits or grounds in the wiring or lighting and starting units. In many cases it will be

found that the battery ignition switch has been left on with the engine idle. Broken jars invariably result from the battery not being properly fastened in place.

Edison Storage Battery. The Edison battery is sometimes called the Alkaline Battery to distinguish it from the Acid Battery. The materials used in its construction are entirely different from the lead cell although both types are made up of plates, separators, jars and electrolyte.

The positive plates are made from a nickel steel grid which holds a number of nickel plated steel tubes vertically, these tubes being filled with alternate layers of nickel hydrate (green) and pure flake nickel. There are 350 of these layers to each inch of tube. The negative plate is formed of a nickel plated steel grid having pockets filled with an iron oxide and a small percentage of mercury to increase the conductivity.

The positive plates are assembled in one group and the negatives in another group, there being one more negative plate than positive in each cell.

These plates are kept from actual contact by hard rubber rods placed vertically between the positive and negative, the plates alternating in polarity through the cell. The set of plates rests on a hard rubber frame on the bottom of the container, being held about one-half inch from the bottom.

The positive and negative plates, assembled, are placed in a nickel plated steel jar and the top of the jar is welded on. There is a hole in the cover which is closed by a hinged cap, the cap carrying a check valve that opens outward only, this being for the escape of gas. By lifting the hinged cap the cell is filled with the electrolyte to a point one-half inch above the tops of the plates.

The electrolyte is composed of pure distilled water with 21 per cent of potassium hydrate (caustic potash) and a small quantity of lithium hydrate. The specific gravity of this electrolyte when new is 1.250 and this gravity remains practically constant for long periods of time. The gravity does not change with the charge and discharge but will finally fall to 1.150 after one to two years' use when it is replaced with fresh solution.

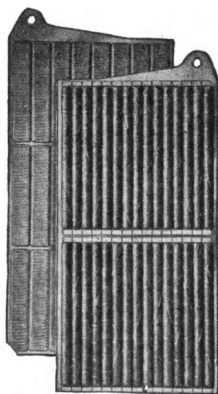

EDISON BATTERY PLATES, POSITIVE BEING IN FRONT OF THE NEGATIVE.

As the battery is charged the iron oxide in the negative plate is changed to metallic iron and the nickel hydrate in the positive plate is changed to black nickel oxide. The oxygen passes from the iron to the nickel and on the discharge the process and changes are reversed.

The voltage of each cell of this type of battery is $1 \frac{2}{10}$ ths, the six volt battery having five cells, the twelve volt having ten cells, etc.

The Edison battery is about half the weight of a lead battery having the same capacity and it is not damaged by vibration, overcharge, idleness without attention or short circuiting. No sediment forms in the jars, making it unnecessary to take them apart for cleaning.

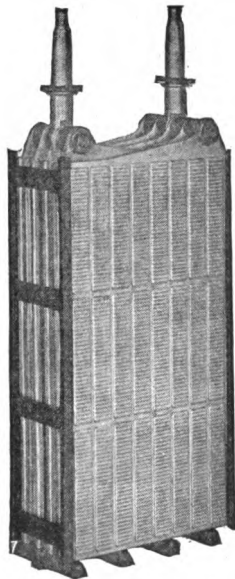

EDISON BATTERY PLATES ASSEMBLED READY TO BE PLACED IN CONTAINER TO FORM ONE CELL.

This battery is charged at an ampere rate representing one-fifth of the ampere hour capacity of the battery and the discharge rate is the same as the charging rate (normal). Frothing of the electrolyte indicates that there has been sufficient rate of charge. The voltage of the battery indicates the state of charge.

It is necessary to give the battery $1 \frac{2}{5}$ ths times the charge in ampere hours that is drawn out of it. That is, for every 100 ampere hours drawn from the battery 140 ampere hours charge must be given. The discharge rate should be the same as the normal charge (one-fifth the ampere hour capacity) but in any case

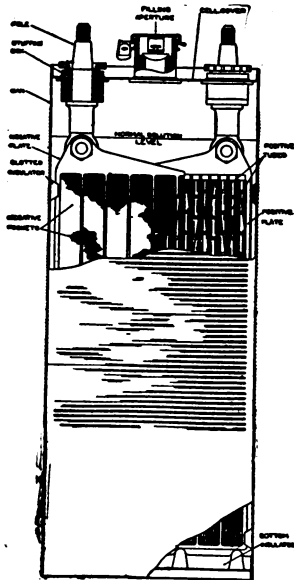

SECTION THROUGH EDISON BATTERY CELL.

it should not exceed this rate by more than twenty-five per cent on the average.

The voltage of the charging current should be at least $1\frac{1}{2}$ times the voltage of the battery on discharge.

The battery will stand a heavy overcharge, being capable of taking a charge for five minutes at five times

the normal rate, for fifteen minutes at four times the normal rate, for thirty minutes at three times the normal rate and for one hour at twice the normal rate.

The cells should be be kept filled with pure distilled

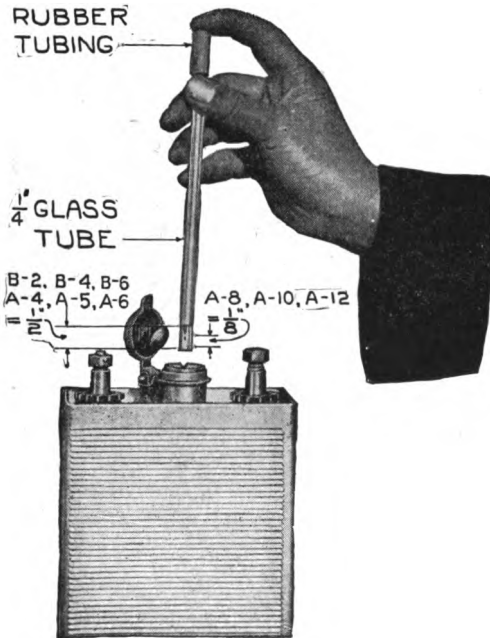

METHOD OF TESTING HEIGHT OF SOLUTION ABOVE PLATES IN EDISON STORAGE BATTERY.

water to a point one-half inch above the tops of the plates and any spilled or lost electrolyte (except that lost through evaporation) should be replaced with Standard Renewal Solution manufactured by the Edison Storage Battery Company. Never use acid or any

articles that have been used around a lead battery. Flame should be kept away from the battery cell caps.

After long use the specific gravity of the electrolyte will fall to 1.150 and at this point it should be poured out of the battery and replaced with new Standard Renewal Solution. Pour about half the liquid out,

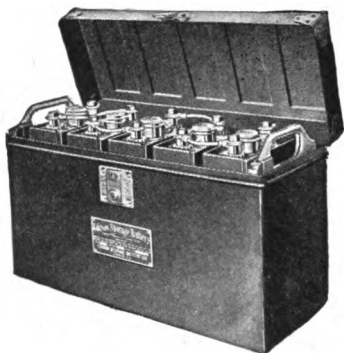

EDISON LIGHTING BATTERY.

shake the remainder well and empty the cell completely. Before doing this the battery should be fully discharged by short circuiting it for about half an hour. The electrolyte will freeze solid only when the interior of the battery reaches a temperature of 24 degrees below zero.

THE CUT-OUT.

There are three general divisions into which the various forms of cut-outs may be divided. These include hand operated, centrifugally operated and electro-magnetically operated forms.

Hand Operated. This is the simplest form in use, being simply a switch that completes the circuit between the motor-generator and battery, and the ignition parts with the same motion. This also forms the starting switch.

In this system a dynamo and motor are combined in one unit and connected positively to the engine without the use of overrunning clutches. The gear reduction must therefore be low and for two reasons the motor-generator must be of large size.

One of these reasons is that, having a low reduction the motor must be powerful in order to start the engine. The other reason follows:

When the combined switch is closed the current is sent from the battery to the dynamo and as the battery current is of higher voltage (the dynamo standing still) the dynamo acts as a motor and starts the engine spinning. The same switch has a connection that turns on the ignition when it starts the motor so that the engine immediately begins to fire and run on its own power. The switch is left closed while running.

The dynamo being of such large size it generates a higher voltage than the battery just as soon as the gasoline engine starts running and at any speed at

which the gasoline vapor will ignite (and run the engine) the dynamo makes a voltage higher than that of the battery.

This higher voltage of the dynamo prevents the battery from discharging through the dynamo and causes the current to flow from the dynamo to the battery performing the work of charging as long as the engine runs.

To stop the engine the switch is simply opened which

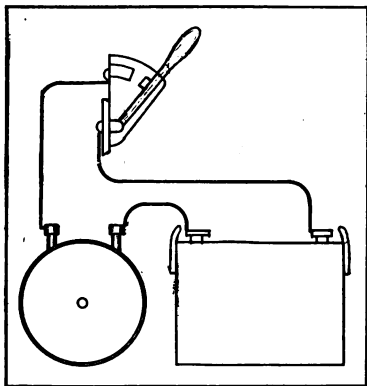

HAND OPERATED CUT-OUT.

stops the ignition and breaks the connection between the dynamo and battery preventing battery discharge.

Should the engine cease to fire or stall, the dynamo, being connected to the battery, immediately acts as a motor again and starts the engine or else turns the engine and drives the car with the power of the electric motor.

Centrifugal Types. When a weight is whirled around a point the weight tries to fly out and away

from the point. The faster it whirls the harder the weight pulls. This force or pull is called centrifugal force.

(1) Centrifugal governors such as are used in cut-outs are usually made with two small weights carried on short arms, these arms being pivoted to a revolving shaft such as the armature shaft. The weights are held

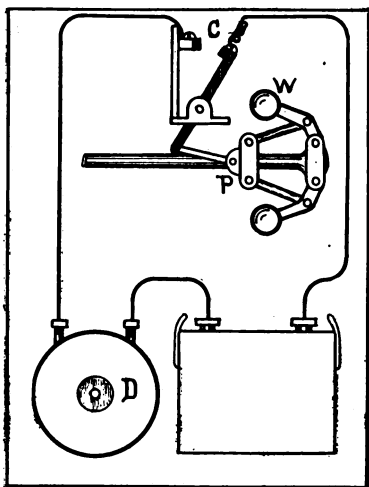

CENTRIFUGAL GOVERNOR CUT-OUT.

D, Dynamo; C, Cut-out contact points; W, Governor weights; P, Sliding block and lever operating contacts.

close to the shaft by springs, but as the speed of the shaft increases, the power of the springs is overcome by centrifugal force and the weights move out from the shaft and cause the arms to move. These arms are connected with some form of lever which moves farther and farther the faster the shaft turns and the more the weights pull out.

This moving lever or rod operates a switch which connects the battery with the dynamo. When the shaft is idle with the dynamo standing still the weights are close to the shaft and the switch is open. As the speed increases to a point where the voltage of the dynamo becomes higher than that of the battery the movement of the governor closes the switch and the dynamo charges the battery.

(2) Another form of centrifugal cut-out switch is called the mercury type. It is composed of a hollow cylinder with the outside divided into a number of sections and insulated from each other. The ends are closed with insulating material and inside the cylinder is placed a small quantity of mercury. The cylinder is attached to a moving part of the dynamo. Brushes are placed in contact with each side of the cylinder, the brushes being directly opposite each other, one being connected to the dynamo and the other to the battery. With the cylinder idle no current can pass from one brush to the other through the cylinder on account of the insulation between the sections. As soon as the dynamo revolves the cylinder the mercury spreads around the inside of the cylinder completing the connection between the sections and the two brushes. The amount of mercury is made such that it completes the circuit when the dynamo voltage has become greater than that of the battery and charging takes place.

(3) There is another form of sectioned cylinder with brushes, but in place of having mercury inside the cylinder there is a set of weights held away from the inside of the cylinder by springs. As the speed of the cylinder increases the weights fly out and complete the connection.

Electro-Magnet Operated Types. Before considering this type some of the principles on which electro-magnets operate should be clearly fixed in mind.

If an electro-magnet is connected in series in any line, that is, if the line or wire is cut and the two ends of the magnet winding are attached to the cut ends, this magnet will get stronger and stronger as the flow of amperes in this line increases. This is called a series electro-magnet and is said to operate by amperage.

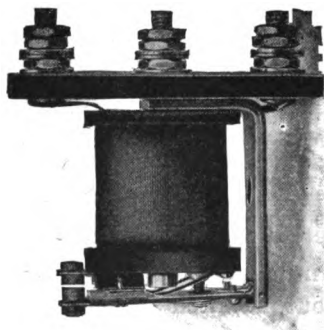

ELECTRO- MAGNETIC CUT-OUT.

If an electro-magnet is connected in any circuit as a shunt so that the main flow of current passes by the magnet and only part of it flows through the magnet this magnet will get stronger and stronger in its pull as the voltage in the lines increases. It is called a shunt electro-magnet and operates on voltage.

When a piece of iron or steel is placed close to the end of an electro-magnet it will be pulled toward the magnet when there is a flow of current through the magnet. If this piece (called the magnet armature) is

held away from the end of the magnet by a spring the armature will not move toward the magnet until the pull in the magnet caused by the increase in amperage or voltage is great enough to overcome the action of this spring. The tighter the spring tension the greater will the amperage or voltage have to be to overcome it.

The windings on an electro-magnet may all run one way or they may be in two parts, running opposite ways forming a bucking coil so that one winding tends to make the magnet strong but the other winding tends to destroy the magnetism and weaken the magnet. This forms a differential electro-magnet.

(1) The simplest form of electro-magnetic cut-out is arranged as follows: There is a plain electro-magnet connected in shunt, with its armature held away by a spring that requires a pull from the magnet, caused by a voltage higher than that of the battery.

The wire from the battery is led to one platinum contact of the cut-out mounted on the magnet armature or stationary. The dynamo wire is carried on another platinum contact arranged so that when the armature touches the magnet these contacts are brought together.

When the voltage from the dynamo rises above the battery voltage the armature is pulled to the magnet against the action of the spring, closing the contacts between the dynamo and battery and allowing charging to commence. As soon as the dynamo speed falls so low that its voltage is less than the battery the spring opens the cut-out, preventing battery discharge through the dynamo.

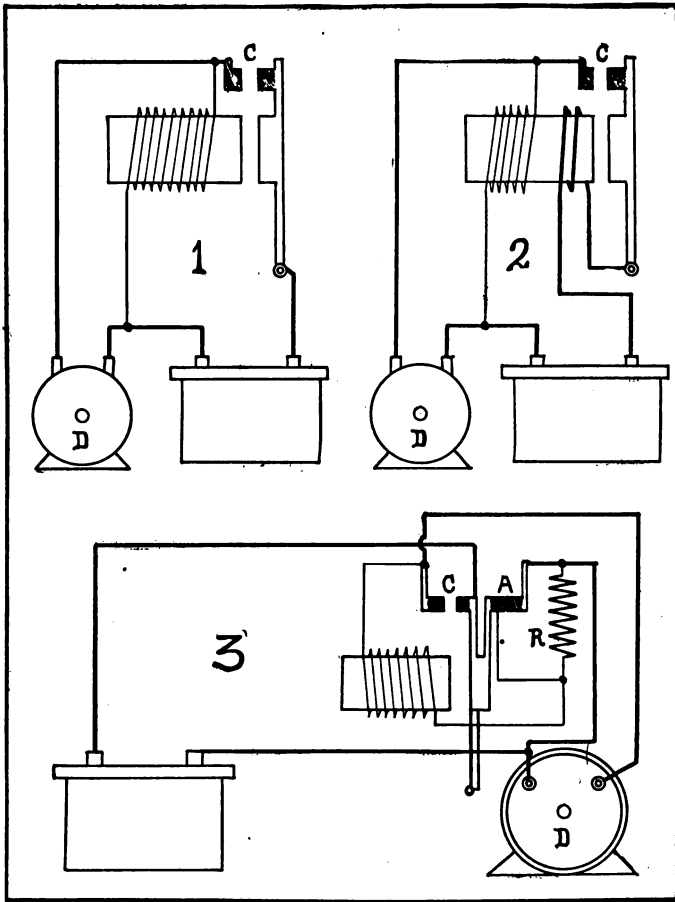

ELECTROMAGNETIC CUT-OUTS

1, Simple shunt connected coil; 2, Compound wound coil on magnet; 3, Current ordinarily passes through closed contacts (A) to shunt magnet coil, closing the cut-out contacts (C) and opening (A), forcing the magnet current through resistance coil (R).

(2) A variation of this type has two windings on the magnet, both running the same way and acting together. One winding is connected in shunt so that when the voltage rises high enough the cut-out closes and completes the circuit for charging. This charging current flows through the other winding, making the magnet hold its armature even tighter. Should the voltage of the dynamo fall below that of the battery the current starts back through this second winding in the opposite direction from the battery to the dynamo. Just as the voltage changes there is no flow and the magnet releases its hold and the contacts open. A momentary reverse flow causes the second winding to buck the shunt so that their power is completely destroyed, allowing the spring to easily open the contacts.

(3) One form of electro-magnet cut-out has two separate electro-magnets mounted end to end and one above the other. The lower one is hinged so that it can fall away from the top one which is stationary. There are arms attached to the two magnets carrying platinum contacts that close the circuit between the battery and dynamo for charging. The upper coil is connected in shunt and when the voltage rises it attracts the lower coil to it, closing the circuit. The charging current then flows through the lower coil, which is in series, causing them to hold tight together until the voltage drops. As the current starts to reverse and flow backward through the lower magnet its polarity is reversed and it repels the upper magnet, opening the circuit.

(4) Still another form is arranged so that when the charging contacts come together another set of con-

tacts open. When this second set is open or apart the current flows through resistance wire before reaching the electro-magnet coil. When these extra contacts are touching, the current to the electro-magnet coil flows through them in place of through the resistance, making the magnet pull its armature toward it. As the armature touches the magnet and completes the charging circuit the second contacts open and the current flowing to the coil through the resistance lowers the holding power of the magnet on the armature to a point such that the charging contacts are easily opened by a light spring when the current starts to reverse.

Cut-Out Indicators. Whenever the cut-out charging contacts are closed the battery is supposed to be undergoing charge from the dynamo, or, even if not being charged, the dynamo voltage is high enough to prevent discharge of the battery. If an ammeter is connected to the battery it will show a charge at this time, pro-

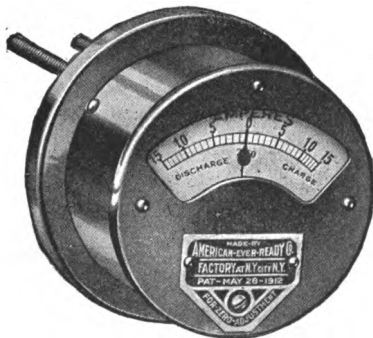

AMMETER FOR USE IN LIGHTING AND CHARGING CIRCUIT.
 Showing adjustment at lower part of front cover.

vided too many lamps are not turned on, thus serving to tell the driver that the battery is being properly charged, or, with the engine running fairly fast, if the ammeter does not show charge then the driver may know the dynamo is not generating or that there is a broken or loose connection somewhere.

Some cars that do not have an ammeter have an extension moving with the armature attracted by the magnet. This extension has the letters C and O on it. When the cut-out is closed the letter C appears through a little glass window, indicating a charge, and when the contacts are open the letter O appears, indicating off.

Other systems have a small electric lamp arranged so that it is turned on when the cut-out is closed. This lamp is on the dash and whenever it is burning the battery is being charged.

Cut-Out Regulation. The cut-out should close the contact between the battery and dynamo just as soon as the voltage is high enough to charge the battery. This is usually almost as soon as the engine starts to run. The spring tension should be lessened or other regulating device adjusted so that the cut-out closes quicker and quicker, that is, at lower and lower car speeds until a point is reached where the ammeter shows a discharge when the cut-out closes, indicating that the dynamo voltage is not high enough. The adjustment may then be set back a very little to prevent this discharge.

The cut-out is supposed to be closed at all times during which the car is being run at average speed. If

the average driving speed is twelve miles per hour then the cut-out should be closed at a speed a little below twelve miles per hour, otherwise the car will be driven most of the time without charging the battery.

Hand-operated cut-outs have no adjustment, lessening spring tension on others, charges the battery at a lower speed.

CURRENT OUTPUT REGULATION.

There are two qualities of an electric current that require to be controlled or regulated for the successful charging of storage batteries and lighting of lamps. One of these qualities is the voltage or pressure, the other being the flow or amperage. In some of the early forms voltage regulators were installed in the form of resistance units operated by a sliding switch with a centrifugal governor, inserting more resistance as the speed and voltage of the dynamo increased and in this way preventing too high a voltage in the lighting lines.

It is a fortunate fact, however, that when a storage battery is carried on the lines between the dynamo and the battery this battery acts as a very efficient voltage regulator. If a six-volt battery is connected on the lines so that the negative terminals of the dynamo, battery and lamps are all fastened together and the positive terminals of the three units are all fastened together the voltage in the whole system outside of the dynamo will not rise above the voltage of the battery, practically six volts being maintained at all times throughout the system. If the battery is a twelve-volt unit the voltage will be maintained at twelve throughout the system and so on.

The actual voltage and amperage made and delivered by the dynamo become greater the more speed the dynamo runs at and decrease as the speed falls. The amperage delivered to a lead battery must not rise above one-eighth of the battery capacity in ampere

hours, the charging rate being measured in amperes. The dynamo being run from the engine and the engine running at speeds from 250 to 2500 revolutions a minute in ordinary use it is evident that some means must be provided for preventing excessive charging rates.

There are more than a dozen ways of accomplishing this and there are fully a dozen variations of some of these methods. Luckily but a very few methods are actually in use so that the repairman can easily become familiar with the principles of operation of the ones commonly found and with their principal variations.

The output of a generator in amperes may be limited by causing electro-magnets to change some condition of operation, by other electrical means or by mechanical means. Methods that affect the magnetic lines of force from the fields include means for increasing or decreasing the flow of current around the fields, using compound or differential field windings, by using such a small field core that it will not increase its strength above a certain point, by using additional brushes between the regular collecting brushes that cut off part of the lines of force, by having extra field poles between the regular poles that pull the lines of force to one side or by making it possible to rotate the fields around the armature slightly while the brushes remain stationary. These methods take advantage of the fact that an increase or decrease in the field strength causes an immediate increase or decrease in the output of the dynamo.

Mechanical control may be effected by causing breakers to induce currents to flow through the fields in a reverse direction, by moving the pole pieces from

between the magnet poles and armature core leaving a greater air gap, by operating the dynamo at a steady speed or by operating the dynamo from a steady and constant force or power.

Practically all means of regulation in use increase or decrease the strength of the currents flowing around the field coils and consequently affect the strength of the magnetic fields (this type including differential windings or bucking coils) or else they drive the generator at a constant speed. Other methods are used in rare cases.

Many variations and combinations of the above types



CONTROLLER AND CUT-OUT (LEFT) AND DYNAMO (RIGHT).

of control are used but these principles cover all cases.

The regulating systems may be grouped as follows:

I. Changing the field current and strength.

- (1) Varying resistance in field windings.
- (2) Controlled compound field windings.
- (3) Controlled bucking coil field windings.
- (4) Using a large field winding and small core.
- (5) Extra brush machines.
- (6) Extra magnetic pole machines.
- (7) Rotating the fields to a new position.
- (8) Permanent magnets with field windings.

II. Mechanical or semi-mechanical control.

- (1) Constant armature speed.
- (2) Constant power driving armature.
- (3) Reverse field currents induced by breaker.
- (4) Movable pole pieces or movable armature position.

All forms of current output regulation take it for granted that the dynamo is capable of generating a flow in amperes that is too great for the work of battery charging and lamp lighting.

Means are always provided for decreasing the output

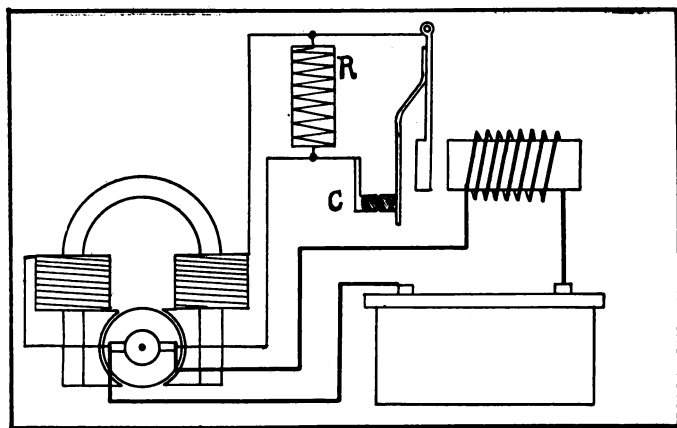

OUTPUT CONTROL, SHUNT FIELD RESISTANCE.
(Ward Leonard Type.)

when it becomes too great but very little provision has been made for increasing the output when it is too little.

Actual observation usually fails to discover batteries damaged by overcharging but this same observation shows hundreds of batteries injured or ruined by undercharging. Undercharging of the battery is in many

cases the fault of the driver through ignorance or neglect. It being impossible to educate the whole number of users of these systems (numbering hundred of thousands) in their proper operation and care the only thing remaining is to provide means for better and more battery charging and in adopting means for forcing the proper care of batteries, especially in the replenishment of water. This will have to be taken care of in some way to insure the success of these systems.

The greatest single trouble encountered by repairmen is that of discharged batteries.

Varying the Shunt Field Current. The shunt field winding has one end fastened to one of the brushes, the other end leading to a resistance of some kind. Arrangements are made for inserting this resistance in the shunt field circuit before its return to the other brush, or for cutting this resistance out of the circuit and allowing the current to return directly to the other brush. Many forms of resistance are used and there are many methods of varying or controlling this resistance.

(1) One well known system using this type of control is the Ward-Leonard. In this system there is a small coil of high resistance wire in a case on the dash together with a series connected electro-magnet in the main charging circuit. This magnet increases its pull as the amperage in the charging line increases and this increased pull draws a magnet armature toward the magnet. This armature carries one platinum contact which is connected to one end of the shunt field winding and when the armature is away from the magnet this contact touches another contact which is connected to the brush on the commutator. This allows the cur-

rent to return from the shunt field to the brush through the platinum contacts but when the current increases enough to pull the armature, these contacts are separated. When they are apart the field current must return through the resistance coil; this reduces the strength of the field and the output of the dynamo. The

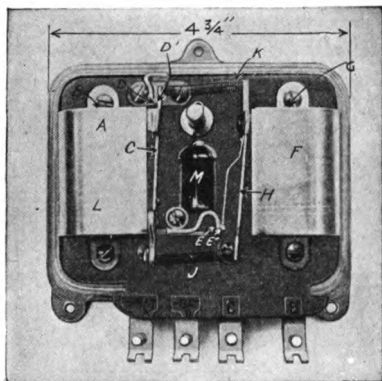

CONTROLLER AND CUT-OUT. (Ward Leonard.)

A-B, Coil and core of magnet for the cut-out, having both shunt and series windings; C, Moving arm attracted by magnet and carrying contact; D-D, Cut-out contacts which close charging circuit; E-E, Regulator contacts which close normally to complete the shunt field current without any resistance; F-G, Coil and core of regulator magnet, carrying winding in series with charging of battery; H, Moving arm of controller which opens contacts (E-E) when attracted by magnet with increase in charging current; J, Spring for holding contacts (E-E) closed; K, Spring for holding cut-out contacts open; L, Series coil location in cut-out magnet; M, Resistance inserted in shunt field circuit when contacts (E-E) are opened by magnet (F).

lessened output passing through the electro-magnet lessens its pull and a small spring pulls the contacts together again, cutting out the resistance and allowing the output to increase. In operation the armature vibrates continually, opening and closing the contacts rapidly. Increasing the spring tension increases the output of the dynamo.

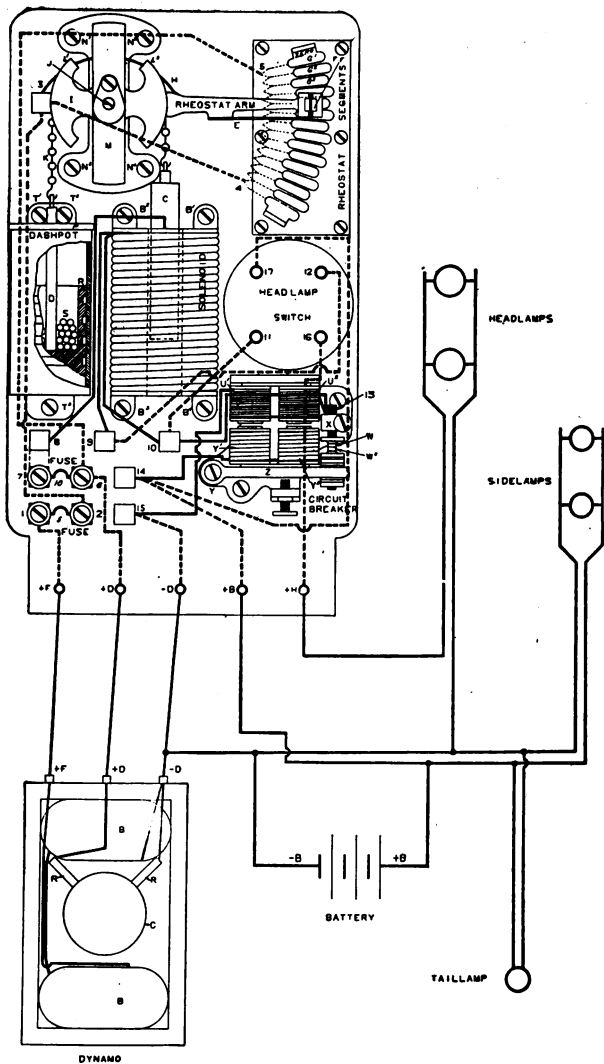

COMPLETE WIRING DIAGRAM OF TYPICAL (ADLAKE) LIGHTING SYSTEM SHOWING INTERNAL WIRING OF REGULATOR, CUT-OUT AND LIGHTING SWITCHES.

ELECTRIC LIGHTING AND STARTING 119

(2) Another form is composed of a solenoid with a movable plunger. This plunger is supported in the solenoid by one end of a small chain, this chain passing over a pulley and being balanced at the other end by a small container holding small lead shot. This pulley

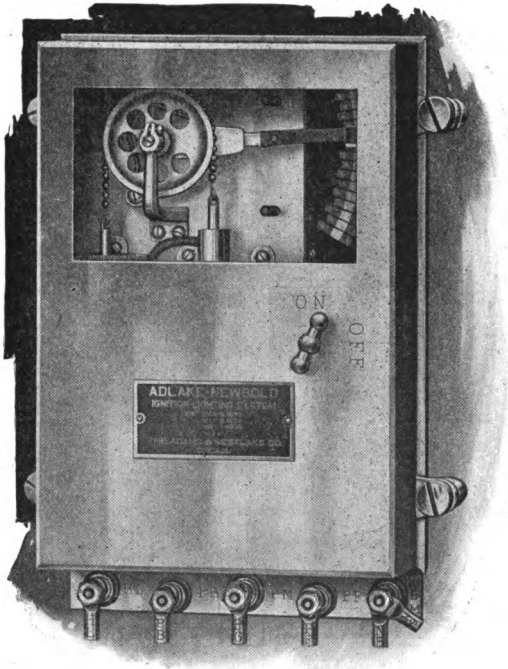

REGULATOR USING A SOLENOID WITH MOVABLE PLUNGER OPERATING A RHEOSTAT. CUT-OUT IS CONTAINED IN SAME CASE.

carries a movable arm that is connected to one end of the shunt field winding and makes contact with various points on a rheostat so that movement of the arm downward when the pulley moves increases the resistance in

the field winding. As the charging current (passing through the solenoid) increases, the solenoid pulls the plunger deeper and deeper into the coil. This lowers the rheostat arm, increasing the shunt field resistance and lowering the output.

(3) Still another form uses a number of carbon discs loosely piled on each other. One end of the field wind-

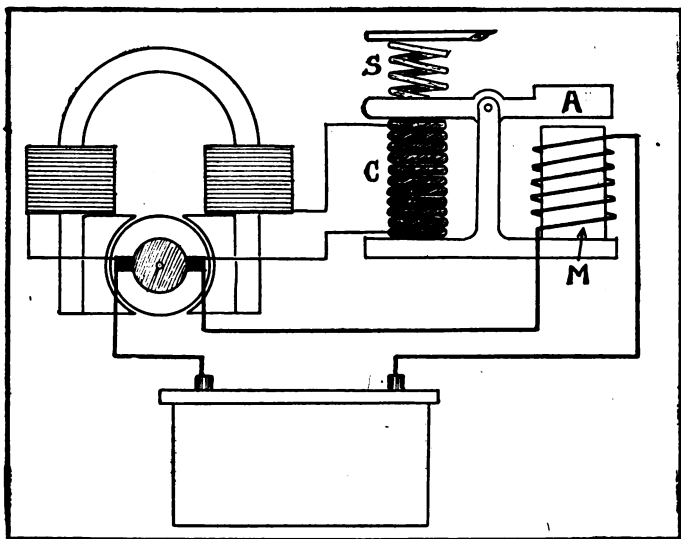

OUTPUT CONTROL, SHUNT FIELD RESISTANCE.

C, Carbon disc pile; S, Spring holding discs together; M, Magnet in series with battery; A, End of arm pulled by magnet, releasing tension on discs.

ing is attached to the upper carbon disc, the lower disc being connected to the dynamo brush. When these discs are loose upon each other their resistance is high but they are held tight together by a pivoted arm across the top which holds them down, the arm being pivoted and forced down by a spring.- The arm rests on the

discs. Near the arm is an electro-magnet that carries the charging current and as the amperage of the charging current increases this magnet pulls on the arm against the spring action and releases some of the pressure on the discs. This increases the resistance in the shunt field and lowers the output. Lowering the output decreases the pull of the electro-magnet and the discs are pressed tighter together, reducing the resistance and increasing the output. Increasing the spring tension increases the output.

(4) Some forms use several windings on an electro-magnet or solenoid, these windings causing the magnet or solenoid to hold resistance in the shunt field circuit. Turning on more lamps cuts out some of these windings so that all the resistance is not held in the circuit, increasing the output to take care of the additional load.

Controlling the Armature Position. This system is not used in this country. As the speed increases the output, the additional strength of an electro-magnet pulls the armature endwise out of the field against the action of a spring. All of the lines of force do not go through the armature and the output is lessened.

Controlling Pole Piece Position. This system is not much used in automobile work at present. The pole pieces are slid out from between the armature and field magnets increasing the air gap that the lines of force have to travel and thus lowering the output.

Compound Field Windings. One system of compound windings is connected so that only the current for the lamps passes through the series winding. This additional current increases the power of the magnets and makes the field stronger.

Compound winding tends to maintain a uniform output.

Section 4
 122 ELECTRIC LIGHTING AND STARTING

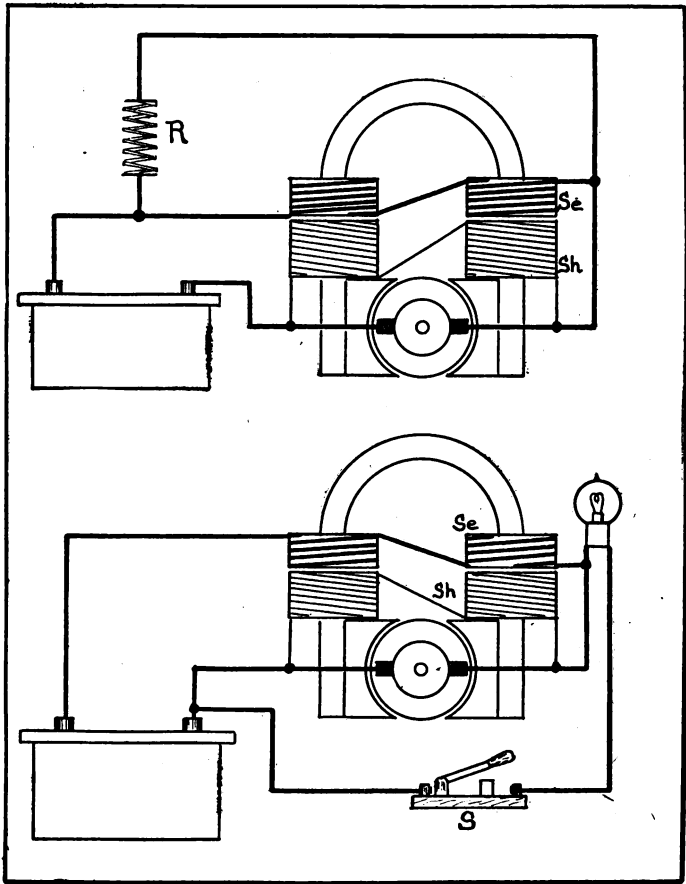

1 OUTPUT CONTROL, BUCKING COILS.
 Upper—Bosch-Rushmore system: R, Ballast coil; Sh, Shunt winding; Se, Series bucking coil.
 Lower—Bucking coil controlled through lamp circuit; S, light switch; Sh, Shunt field; Se, Bucking coil field.

Bucking Field Coils. One system, the Bosch-Rushmore, has the series coil bucking the shunt. No cur-

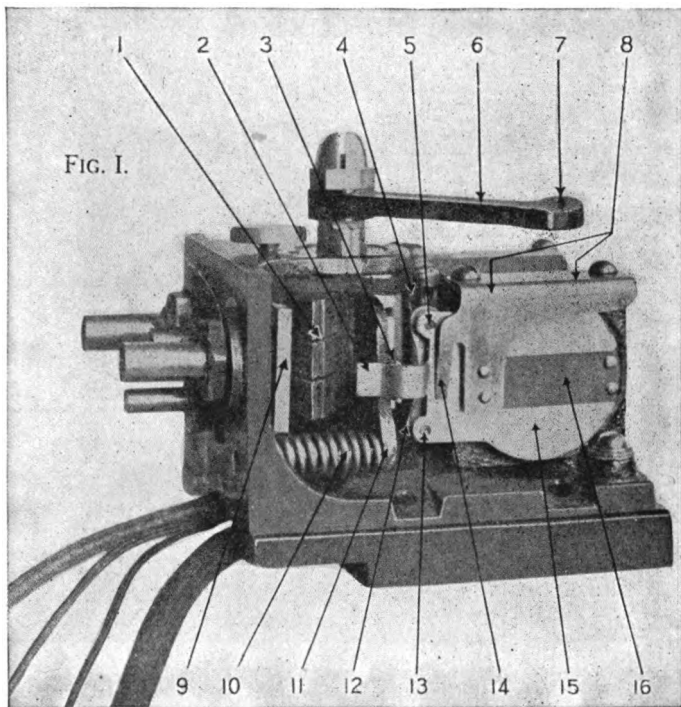

A MOTOR-GENERATOR CONTROLLER.

Showing the electro-magnetic cut-out and the starting switch, the regulator being on the opposite side. 1, Starting switch contact; 2, Arm to hold cut-out open while starting; 3, Button to operate (2) when starting switch closes; 4-5, Cut-out contact points; 6-7, Starting switch lever; 8, Cut-out bracket; 9, Starting switch contact; 10, Starting switch spring; 11, Switch spring arm; 12-13, Cut-out contacts; 14, Arm or stop for contacts; 15, Cut-out magnet armature; 16, Cut-out armature spring.

rent passes through the series coil under ordinary conditions, the current that would ordinarily pass

through this coil going to the battery and lamps through a small coil of iron wire mounted on the dash

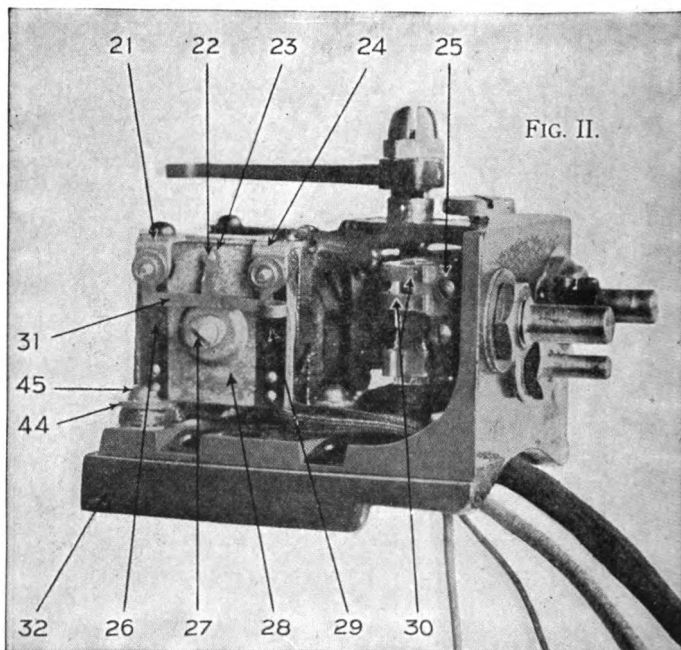

A MOTOR-GENERATOR CONTROLLER.

Showing the electro-magnetic regulator, the cut-out and starting switch being on the opposite side. 21, Regulator bracket; 22-23, Contacts opened and closed by regulator electro-magnet and through which the bucking coil is controlled. When contacts are open current is forced through bucking coil, lowering output; 24, Regulator bracket; 25, Shunt field winding contact, closed except when acting as starting motor; 26, Regulator spring; 27, Regulator adjusting screw, turning in decreases output; 28, Regulator electro-magnet armature; 29, Regulator spring; 30, Shunt winding contacts, same as (25); 31, Regulator armature stop.

board. In other words, this iron wire (ballast coil) is connected in shunt with the series coil. A peculiar property of iron wire is that it carries a certain amper-

age without increase in its resistance but at any higher amperage the iron becomes red hot and the resistance increases to a point that practically prevents further passage of current through the iron. The current then passes through the series coil, bucking the shunt and lowering the output so that the iron wire cools off. --

(2) Another type makes use of permanent magnets with a shunt winding and a bucking series coil on the permanent magnets. At slow speeds the shunt winding assists the permanent magnets but as the dynamo goes faster the shunt winding is cut out by an electromagnet. When the speed increases still more the cur-

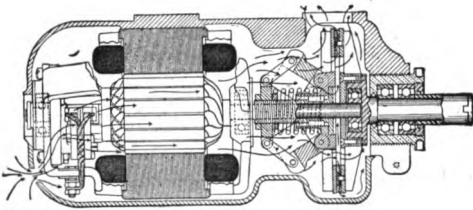

CONSTANT ARMATURE SPEED CONTROL OF DYNAMO.

Showing a slipping plate clutch with its centrifugal governor weights and spring. (Gray & Davis.)

rent flows through the bucking coil but with a resistance coil in series with the bucking coil so that only a little current bucks the permanent magnet. At the highest speeds the resistance is cut out, allowing the full strength of the bucking coil to oppose the permanent magnets.

(3) Still another system uses a bucking coil connected in such a way that the current flows to the battery through the bucking coil when the lamps are turned off. When lamps are turned on the current flows

to the lamps in place of to the bucking coils so that the reduction of force in the bucking coils increases the output to take care of the lamps.

Large Field Coil and Small Core. The strength of magnetism in an electro-magnet increases as the current in the winding increases. This is true up to a certain point at which the iron becomes saturated with magnetism and can become no stronger regardless of the increase of strength in the field coils. This only happens when the coils are extremely large compared to the core of the magnet. The core becomes saturated at the point of amperage desired as a limit, so that the field can not increase its strength nor the output of the dynamo past this point.

Extra Brush Machines. This system has a second brush or set of brushes between the regular set. These extra brushes connect with another set of fields and field windings through a resistance. When the current in these secondary brushes overcomes the resistance the extra poles are magnetized and these overcome part of the effect of the regular poles.

Extra Pole Machines. There are extra poles between the regular ones, these extra poles having no windings. Above a certain speed the lines of force pass into these extra poles in place of entirely through the armature so that their whole effect does not induce currents in the armature and the output is lowered.

Rotating the Fields. The fields are arranged to turn around the armature, being pulled by a governor against the action of a spring. The brushes remain stationary so that they do not collect the current just as the armature windings are changing through the

lines of force but a little before or after this position. This prevents the brushes from collecting the current at its highest value and the output is lowered.

Constant Armature Speed. This is accomplished by having the armature driven from the engine through a friction clutch. This clutch is held in engagement by springs but when the speed reaches a point at which the output is at its safe limit these springs are overcome by centrifugal governor weights and the clutch is released so that the speed and output cannot increase beyond this point.

Constant Driving Power. The varying power and speed of the engine make this system unsuitable for this kind of work.

Reversed Field Currents. If the current flowing through a field winding be broken there is an extra current induced in the fields that flows the same way as the regular current, but, when the current is made again there is an induced current flowing the opposite way and opposing the regular winding. A mechanical vibrator or breaker operates above a certain speed producing these reversed currents and lowering the output.

The systems that the repairman will encounter include the varying field currents produced in various ways, constant speed types, bucking coils and extra brush machines. The other systems are not found in common use, being given simply for completeness and reference.

STARTING MOTORS.

Requirements. To start the average automobile engine requires a starting motor being able to deliver power from one-half to one horsepower.

This starting motor must be able to turn the engine crankshaft at a speed from 50 to 125 revolutions per minute in order to start the engine with good carbu-

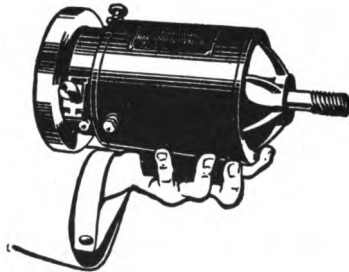

SMALL HIGH POWER STARTING MOTOR UTILIZING
WORM DRIVE.

retion and ignition. It is easier to start and turn an engine at 100 revolutions per minute than at lower or higher speeds.

Power. Seven hundred and forty-six watts equal one mechanical horsepower, so by dividing the average power required in watts by the voltage of the system the required amperes may easily be found.

Drive. The drive is taken from the motor to the crankshaft or flywheel through chains or gears. The

reduction may take place through trains of spur gears, planetary gearing, eccentric gears, internal gears or worm gearing. Combinations of these systems may be used and they may be combined with silent chains.

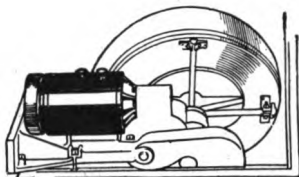

STARTING MOTOR APPLIED TO CLUTCH SHAFT.

Engagement between the motor and engine may be through sliding gears, jaw clutches or friction clutches. In some types universal joints are used to prevent strain on the bearings.

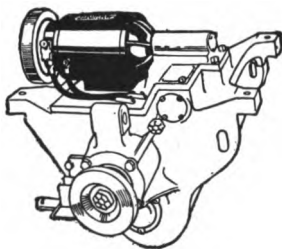

STARTING MOTOR DRIVING INTO TRANSMISSION GEARS.

ELECTRIC BRAKE.

One of the most recent developments in the application of electricity to the control of the automobile is found in the Hartford electric brake. This consists of a small electric motor mounted to pull on a brake cable with a force of 1000 pounds, bringing the car to a quicker and smoother stop than with the hand brake.

The motor is of small size, series wound and of the reversible type. The end of the armature shaft carries

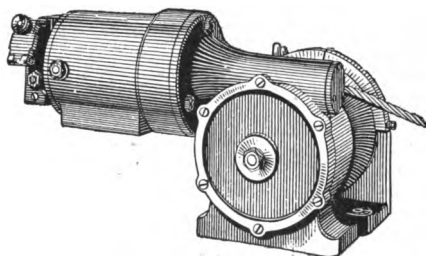

MOTOR AND CABLE DRUM OF ELECTRIC BRAKE.

a worm that meshes with a worm gear, giving a reduction of 100 to 1. This worm gear operates the brake cable drum through an internal gear, giving a further reduction of 4 to 1, making the total 400 to 1. The steel brake cable is attached to the equalizer of the emergency brake set already on the car, the emergency brake hand lever and pull rod being removed.

The brake is controlled by a handle within reach of

the driver, usually on the steering wheel. This controller has three positions, the first one releasing the brake, the next one giving pull enough for ordinary braking and the third one giving an emergency stop. Returning to the first position releases the brake in all cases. A slipping friction clutch prevents the application of more than 1000 pounds pull and a ratchet holds

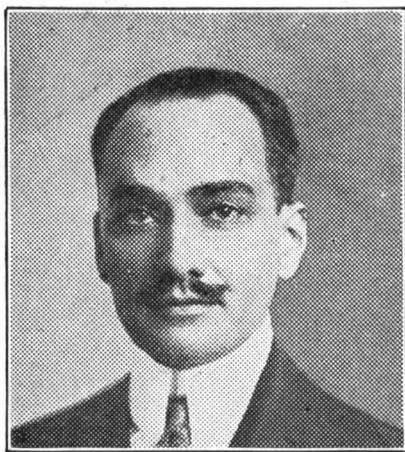

EDWARD V. HARTFORD
Inventor of the Hartford Electric Brake

the brake, when once applied, until it is released by the operator.

The complete outfit weighs about thirty-five pounds and requires a flow of about forty amperes for two-fifths of a second for the application, the same amount of current used by the tail lamp in one-twentieth of a minute while burning.

Section 4
132 ELECTRIC LIGHTING AND STARTING

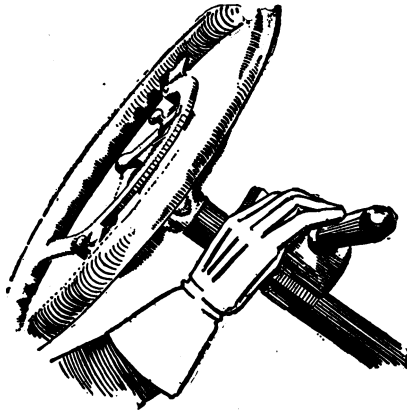

STEERING WHEEL CONTROL OF ELECTRIC BRAKE.

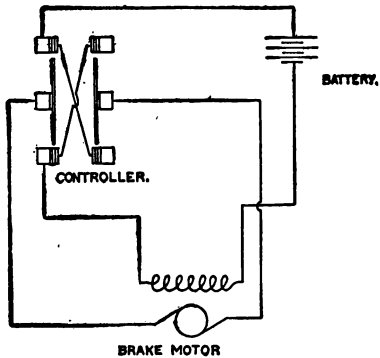

WIRING DIAGRAM OF HARTFORD ELECTRIC BRAKE.

ELECTRIC GEAR SHIFT.

Changing the position of the sliding gears in the selective transmission by electricity has proved desirable and a great convenience in many cases. The mechanism and its operation are both very simple, being substantially as follows.

The shifter rod of the transmission is not attached to the hand lever pull rods but has an iron plunger at each end, front and rear. These cores are arranged to be drawn into a solenoid when current from the battery is allowed to pass through the solenoid windings. There are four solenoids, one each for low, intermediate, high and reverse speeds, these corresponding to the four iron cores, two on each shifter rod.

The flow of current to these solenoids is controlled by press buttons located on the steering wheel or within easy reach of the driver. There are five of these switch buttons, one each for low, intermediate, high and reverse speeds and one extra button that returns the gears to the neutral position from any of the speed positions.

These selector buttons do not make the circuit complete between the battery and solenoids but they make the connection that determines which of the solenoids the current will pass to when the master switch is closed. This master switch makes the connection complete and causes the solenoid to act on the iron core, bringing the gears into the desired position for use. The master switch is connected to the clutch release pedal in

such a way that the circuit is not completed until the clutch is depressed all the way.

The action is as follows: The operator depresses the selector button controlling the speed he desires to use and when he is ready to start or move the car in that speed he depresses the clutch pedal clear to the floor. This closes the master switch and the gears are immediately snapped into position. Allowing the clutch to engage in the usual way causes the car to move.

The operator may now depress the selector button of the next speed he desires to use, either higher or lower, but this does not immediately shift the gears. When he is ready to make the change it is only necessary to press the clutch pedal clear down and the shift is made positively.

Pressing the neutral button brings the gears to the neutral position through the action of the solenoid and a small stop, preventing the gears traveling into another speed position.

AMMETER READING.

(1) With the engine and dynamo running and the lamps turned off the ammeter should give a reading of a steady charge of not more than one-eighth of the battery capacity in ampere hours at a car speed of fifteen to twenty miles an hour and not less than one-ninth of the battery capacity with the engine running at its highest safe speed.

Should the reading be zero trouble may be found in a defective ammeter, a dynamo not generating or wires disconnected. If the reading should show a discharge the ammeter connections or dynamo connections may be reversed or there may be a bad ground or short circuit in the charging or lamp switch lines. If the ammeter shows too high a charge the regulation is at fault and if the charge is too low there may be short circuited or grounded wires or the dynamo may not be operating properly. A jumping ammeter hand indicates loose connections or that the battery wires are reversed.

(2) With the engine and dynamo running and the lamps turned on the ammeter should show a small charge, a small discharge or zero.

If the indication is a full charge the regulator is at fault or else the ammeter does not register properly.

If the indication is too great a discharge the dynamo may not be generating properly or there may be loose or broken wires or short circuits or grounds.

(3) With the engine and dynamo idle and the lamps turned off the ammeter should show zero. If it shows

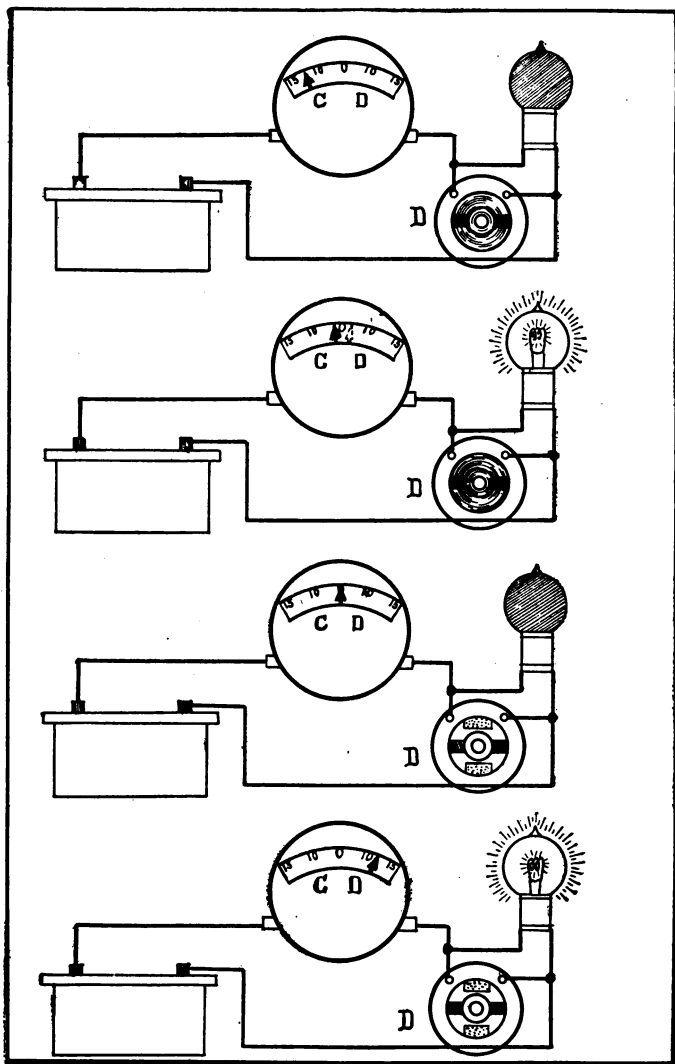

AMMETER READING.

Diagrams from top to bottom—Dynamo running; lamps off; charge indication. Dynamo running; lamps on; slight charge or discharge. Dynamo idle; lamps off; zero indication. Dynamo idle; lamps on; discharge according to lamps.

a charge the ammeter is probably out of order and if it shows a discharge there are shorts or grounds in some of the lines or the cut-out does not open.

(4) With the dynamo and engine idle and the lamps turned on the ammeter should show a discharge of the number of amperes required by the voltage and candle-power of the lamps turned on. If it shows zero the ammeter wires may be shorted on each other or one of the battery wires may be shorted or the ammeter hand may be sticking. Too high a discharge indicates a short or ground and too low a discharge indicates a defective ammeter. A reading of charge indicates wires reversed to the ammeter.

SECTION FIVE

ELECTRIC IGNITION

**Design, Construction, Use, Care and Repair of
Various Units.**

**Subjects in This Section Are Arranged in Alphabetical Order
For Easy Reference.**

BREAKER.

When the current flowing through a transformer coil is suddenly broken or stopped from flowing a very high voltage current is induced in the secondary winding of the coil. This is done by a breaker, the breaker having two contact points tipped with platinum, one of these points being stationary and carried by the

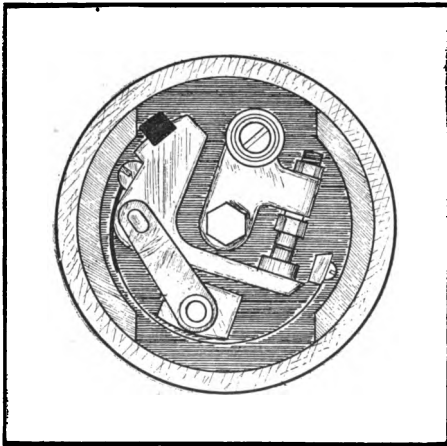

MAGNETO BREAKER (Bosch).

end of a threaded screw. By turning this screw the points may be brought nearer together or farther apart. This screw is locked in place with a jam nut or spring. The other contact point is mounted on a lever which is pivoted. As the armature or shaft turns this lever

IGNITION

strikes a cam or projection and this cam forces the points to separate against the action of a small spring. The current from the coil passes through the points of the breaker and just as the points separate the spark is produced.

Breakers are usually arranged so that they may be rotated part way around the shaft. Rotating the breaker in the same direction that its shaft runs causes the spark to come later in the piston stroke or retards the spark while rotating the breaker the opposite direction to which the shaft runs causes the spark to

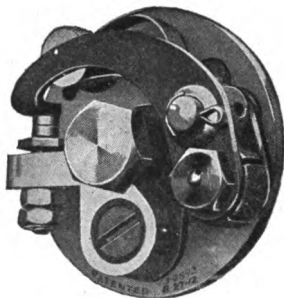

MAGNETTO BREAKER. (Splitdorf.)

come earlier in the stroke and advances the ignition.

Breakers are used on magnetos and also as separate units in connection with batteries and single unit coils. In the latter case the breaker is usually combined with a distributor, the coil and switch being separate. The magneto breaker receives the current from the magneto armature primary winding and if the magneto is used in connection with a battery the breaker may also receive the battery primary current when the switch is in the battery position.

A breaker cam or projection should have a drop of light machine oil applied with a match or toothpick once a month but no other oil should ever be applied in the breaker case. The points must always be kept clean and dry.

The contact points of a breaker must be kept filed clean and smooth and so that they make a full, even contact with each other.

Sometimes a breaker will cause trouble because the movable arm does not operate. This may be caused by the arm sticking on its pivot or because the spring is broken, bent or weak. The arm may possibly be broken.

The adjustable point in the breaker should be set so that the points separate about the thickness of a business card or one-fiftieth of an inch when fully open.

COILS.

The action of a transformer coil is explained in the section on Elementary Electricity under Induction. All forms of transformer coils have a property known as lag. This causes an extremely short interval between the time the circuit is broken in the primary winding and the time when the spark is produced from the secondary winding. This forms one of the reasons for the advancing of the spark as the engine runs faster.

Coils are used in many forms in automobile work. The armatures of all magnetos carry one or more coils. In magnetos that require a separate coil to produce the spark there is only one winding on the armature that produces a low voltage current for use in the separate transformer coil. Magnetos that deliver a high tension spark without the use of a separate coil have two windings on the armature, one winding generating the primary current that is broken in the breaker and outside of this winding there is another winding of fine wire, this second winding being the secondary winding of a transformer coil, the inner winding that generates the current acting as the primary winding and the armature core being the core of the transformer coil thus formed by the two windings.

Other forms of coils include master vibrators ; single unit coils for use with magnetos ; distributors and single spark systems ; vibrator coils having a vibrating breaker attached to the coil and multiple unit coils having a separate coil for each cylinder to be fired.

Master Vibrator. This is a coil having a single winding which is used to operate a vibrator attached to the coil. This coil performs no work of current generation, being used only to operate the vibrator. The master vibrator is used in connection with multiple unit coils having a separate coil and vibrator for each cylinder. It does away with the use of the separate vibrators and substitutes its one well made vibrator which

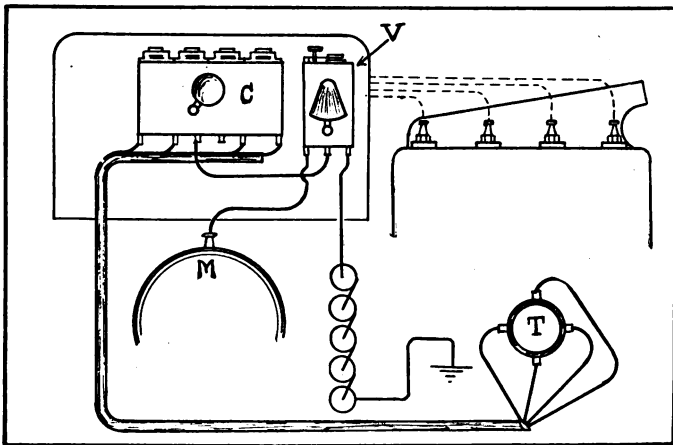

MASTER VIBRATOR WIRING.

C, Old coil; V, Master vibrator coil; M, Low tension magneto; T, Timer.

does the vibrating and breaks the current for all the coils. Its advantage is that there is only one vibrator to adjust, giving a uniform spark in each cylinder.

Master vibrator coils usually have three terminals but may have only two. If there are three terminals it is intended that two of these lead to two separate sets of batteries. With the Ford low tension magneto one

of these terminals should be connected to the binding post on top of the transmission case (the magneto terminal) and the other connected to a set of batteries. The third terminal on the master vibrator should be connected to the terminal of the old coil that formerly led to either the batteries or magneto (low tension magneto only). If this third terminal on the master vibrator is connected to the battery terminal on the old coil then the old switch must remain in the battery position at all times. If it is connected to the magneto terminal on the old coil or switch the old switch must remain in the magneto position at all times.

The exact method of wiring will vary to some extent with the make or type of master vibrator purchased. The coil of the master vibrator may have two or three terminals and they may be marked "B" or "Bat" for connection to the battery, "B1" or "B2" or "Bat 1" and "Bat 2" for connection to two separate sets of batteries on the positive terminals of the batteries or "M" or "Mag" for connection to the low tension magneto terminal. Any terminal marked "B" or "Bat" may be connected to the magneto terminal on the transmission case of a Ford car. A terminal marked "G" or "Grd" should be connected to the metal of the frame or grounded.

Taking it for granted that you are working with a 2, 3, 4, or 6-unit coil, one or more batteries or sets of dry cells or with the Ford magneto the method would be as follows:

1. Screw the master vibrator to the dash of the car near the old coil but do not remove the old coil.
2. Trace the wire running from a battery or from the Ford magneto (not both) to the old coil or the old

switch. Remove this wire from the coil or switch and attach it to one of the magneto or battery terminals on the master vibrator, the terminal marked for battery or magneto, according to which is used.

3. From one of the remaining terminals of the master vibrator (not from a terminal marked "M" or "Mag," or "B" or "Bat") run a wire to the old coil terminal from which you removed the wire mentioned in rule two.

4. You should now have one terminal left on the

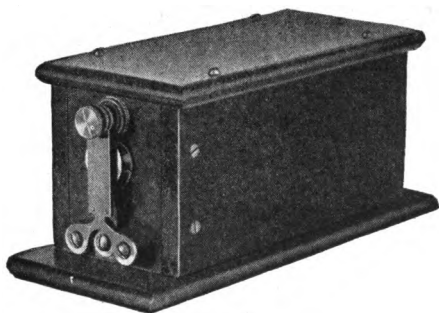

SINGLE UNIT VIBRATING COIL.

master vibrator and this terminal should be connected to the Ford magneto terminal if not already connected to a battery or set of dry cells. This terminal is connected according to its marking, if there is any. (If there were only two terminals on the master vibrator there are no more connections to make.)

If the car originally had another connection besides those mentioned from the old coil to a Ford magneto or another set of batteries, this connection should be removed.

IGNITION

5. If the wire mentioned in rule three was connected to the magneto terminal of the old coil, then the switch on the old coil must be left in the magneto position. If the wire mentioned in rule three was a battery wire then the old switch must be left on the battery position. The switch on the master vibrator is then used for switching the ignition on and off and to either battery or magneto.



FOUR UNIT IGNITION COIL HAVING MASTER VIBRATOR MOUNTED IN CENTER OF BOX.

6. This completes the necessary rewiring, as it is not necessary to use all the terminals on the old coil.

7. Turn the adjusting screw on each of the old coil vibrators until the platinum points are held tightly together or run a short wire that will connect the spring carrying one of the platinum points to the metal carrying the other platinum point. The idea is simply to let the current pass through the coil without causing the vibrator to operate.

A master vibrator is adjusted in exactly the same way that any vibrator is adjusted on any coil.

Single Unit. This is generally understood to mean a transformer coil for mounting anywhere on the car, the coil having no vibrator as a general rule. However, some single unit coils have vibrators in the coil case. A

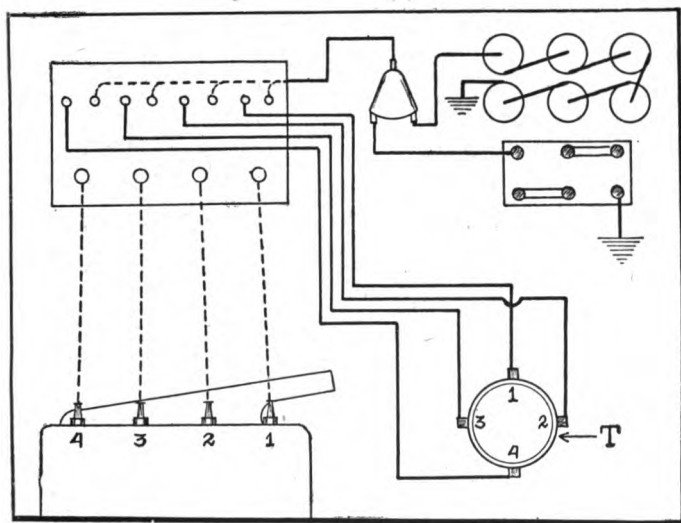

FOUR UNIT COIL AND TIMER WIRING.

Showing storage and dry cell batteries with two way switch leading to common terminal wire and each of the four coils, circuit being completed through separate timer wires.

single unit coil may or may not carry a switch and it may be in a wood or metal box of square or cylindrical shape. It may have from two to six terminals on its case, depending on its use with magneto, battery or both.

Multiple Unit. This means a set of coils, one for each cylinder of the engine. Multiple unit coils usually have a vibrator on each coil although they may be set in a box with a master vibrator when they themselves will have no vibrators.

Multiple unit coil boxes usually carry the switch and are mounted on the dash or under the floor.

CONDENSER.

Whenever a primary current is broken by a breaker or vibrator a heavy spark should occur at the breaker or vibrator points. This spark would soon burn and destroy the points. To absorb the current causing this extra spark a condenser is attached to all forms of breakers.

The condenser consists of a large number of sheets of tinfoil. These sheets are laid one on top of the other with sheets of waxed paper or mica or other insulation between them. Half of the tinfoil sheets (every alternate sheet) stick outside the insulating sheets at one end of the condenser and the other half stick outside at the other end. The sheets sticking out of one end are all pressed together and attached to a wire and all the sheets sticking out of the other end are attached together and are fastened to another wire. The whole arrangement is then enclosed in an insulating covering of wax or other material and only the two wires stick out.

One of the condenser wires is attached so that it has a connection with one of the breaker or vibrator contacts and the other wire connects with the other contact point. The current from one point cannot pass through the condenser and short circuit to the other point because one-half the sheets of tin foil are separated from the other half by the insulating sheets. While the points are not short circuited, the excess current that would make a spark passes into the tinfoil

and is absorbed. When the contact points come together again this absorbed current escapes and does no damage.

Should the insulating sheets become broken or punctured the contacts are short circuited and no spark will occur at the plug, or at best a very weak spark. Should one of the condenser wires become disconnected from one of the contacts a heavy spark will occur when the contacts separate. The remedy is a new condenser.

The condenser is usually carried in the same case with the coil or in the base or above the armature in a high tension magneto.

CONTACT POINT CARE.

The separating points of all breakers and vibrators should be fitted with tips of platinum so that they will stand the heat of the small spark that occurs when they break. Sometimes the platinum is mixed with another metal called iridium to make it harder. No substitute for platinum should be used as it does not handle the current properly. Single platinum contacts are worth at least \$1.20 or more and as a general rule points selling for less than this are not pure platinum.

In time platinum points wear and burn away and when this happens the part carrying the tip may be replaced with a new one or the old point may be pried or driven out of the hole into which it is riveted and a new point bought. The new point has a small part that passes through the hole and is then riveted over on the side opposite the contact. In most cases it is best to secure the entire screw, arm or spring carrying the contact point.

The surfaces of platinum points that touch each other must be kept clean and bright and free from pits, roughness or burned spots. Points should be examined occasionally and if not in good shape they should be dressed by filing with a very fine flat file. When they are filed the surfaces must meet each other exactly even at all points, not only touch at one side or in the center. Points may be easily dressed by drawing a specially prepared strip of cloth between them while they are pressed lightly together. This cloth is covered with

IGNITION

emery or carborundum on both sides and being of an even thickness makes the contacts meet each other properly when the work is finished.

DRY CELLS.

These cells are used for furnishing primary current for use in the transformer coil while starting the engine and before the engine has sufficient speed to produce a spark from the magneto. To a certain extent dry cells provide a reserve ignition system that may be used in case the magneto fails.

Dry cells are composed of a zinc shell enclosed in a

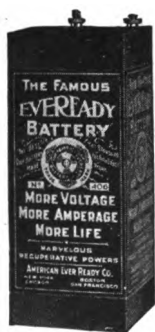

TYPICAL DRY CELL.

cardboard holder with a cardboard bottom. Inside the zinc shell are the active materials that act on the zinc and in the center is a stick of carbon. Inasmuch as the zinc forms one of the elements of the cell it must not be allowed to touch any metal or conductor. To insulate the zinc it has the cardboard cover over it and this cardboard cover must be preserved without break-

ing or chafing through because it is as much a part of the cell as anything else.

Attached to the zinc shell is a small brass screw and nut, this being the negative terminal of the cell. To the carbon in the center of the cell is fastened another small screw and nut forming the positive terminal. The center terminal in any dry cell is the positive and the outside terminal is the negative. In using sets of dry cells in a battery care must be used to see that the negative terminal does not touch another negative



AMMETER FOR TESTING DRY CELLS.

terminal or the zinc of another battery or any piece of metal such as the walls of the battery box.

A single dry cell produces a voltage of $1\frac{1}{2}$, this voltage changing but little whether the cell be new or old. A dry cell contains about ten ampere hours, although much of this amount may be lost through improper use, handling or from old age. When the terminals of a dry cell are short circuited the flow should be between twenty and thirty amperes if the cell is new and good. In testing a dry cell use an ammeter and touch the points only for a moment. A high

discharge from a dry cell causes it to lose its ability to do useful work and if the ammeter or any other conductor is held in connection with the terminals for more than a second at a time the battery will lose much of its life. When a battery is used in connection with a coil the discharge is low enough so that the cell is not damaged. When testing a number of cells try each cell separately from the rest. When a cell shows less than six amperes it should be thrown out of the battery and replaced with a new one. It is not best, however, to place old and new cells in the same circuit because the old cells prevent the proper flow from the new and cause the new cells to overcome the high resistance of the old ones. The new cells will quickly be brought down to the level of the old ones. Neither should different sizes or makes of cells be used together. A battery showing a high amperage on test is not necessarily a good and long-lived battery because the maker can use a strong electrolyte and cause a poorly built battery to show a good test.

A dry cell should not be called upon to give a flow of more than one-half ampere if its full life and current is to be obtained. Under this amount of flow the average life of dry cells in ordinary use will be about twenty hours of actual use. Dry cells lose their power with age whether used or not.

Should it be necessary to restore an old dry cell it may be done temporarily by punching a hole in the top, bottom or side of the cell and pouring water or water mixed with vinegar or acid into the hole. This will cause the cell to deliver current for a short time. There is no method of restoring an old dry cell that will prove at all satisfactory for continued use.

Dry cells are connected together into batteries, thus increasing either the voltage or amperage or both, according to the type of connection used. Cells are connected with short pieces of insulated wire bared at the ends and twisted or turned around the cell terminal or they may be connected with specially made battery connectors. These connectors have brass or copper terminals with holes that go over the battery screws

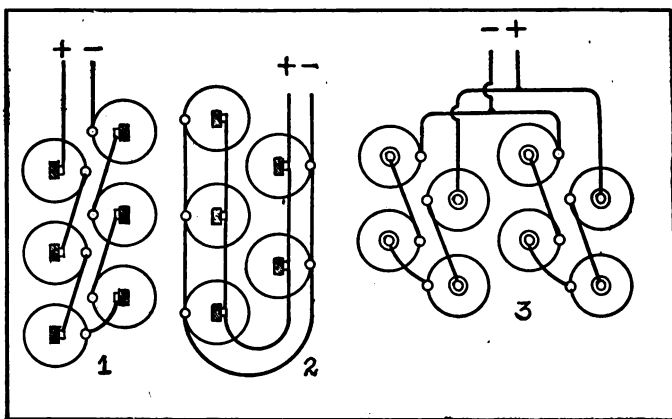

DRY CELL CONNECTIONS.
1, Series; 2, Multiple; 3, Multiple-Series.

and the wire is soldered into the terminal, making a good electrical joint. These connectors cost only about a cent each so should always be used. If the coiled wire is used care should be exercised that no loose strands of wire stick out and touch any metal parts. Another type of connector has spring ends which have two holes, one in each end of the spring. Pressing the spring together brings the holes in line and they are

then passed over the screws of the cells and the spring tension holds them in place. These cost several times what the plain connectors do but are easier to use. In using plain connectors the cell terminal nuts must be screwed tight with the pliers. Screwing them down with the fingers allows them to come loose and give trouble.

If it is desired to obtain more voltage than one cell will give several cells may be connected in series. This means that the positive of each cell is connected to the negative of the next cell, the positive of that cell being connected to the negative of the next one and so on. This leaves one positive and one negative terminal at each end of the set. This connection increases the volt-



"BULL DOG" BATTERY CONNECTOR.

age according to the number of cells, the voltage being found by multiplying the number of cells by $1\frac{1}{2}$ (the voltage of one cell). To secure six volts it would be necessary to use four cells because 4 times $1\frac{1}{2}$ is six. In actual practice, however, it is best to use one additional cell to overcome the resistance of the whole battery and to make sure of the full voltage. Thus, to obtain six volts in actual use we would use five cells in place of four.

The amperage may be increased by connecting the cells in multiple. This connection requires that the negative of each cell be connected to the negative of the next cell and so on, all the negatives being con-

connected together and all the positive terminals being connected together. This makes one negative wire and one positive wire. This connection causes the amperage of the battery to equal the amperage of one cell multiplied by the number of cells used. Thus, four cells, each giving a flow of twenty amperes, will give a flow of eighty amperes if connected in multiple.

When it is desired to increase both the amperage and voltage and also to increase the useful life of the cells a connection known as multiple-series is used. To make this connection: Take the number of cells required to give the desired voltage and connect them in series as directed. You can then use two or more of these series sets of cells. Each set forms a battery giving the required voltage. These sets or batteries are then connected in multiple, fastening the end negative terminals of all the sets together and fastening the end positive terminals of all the sets together. This gives the voltage of one set and the amperage may be found by multiplying the amperage of one cell (not one battery) by the number of sets used.

If a series set of cells will last a certain number of hours a multiple series connection of two sets in series will last four times as long. This cuts the cost in two because, while the multiple series battery costs twice as much, the life is four times as long.

DISTRIBUTOR.

A distributor is a device that takes the high tension or secondary spark plug current from the single unit transformer coil and by making several contacts, one

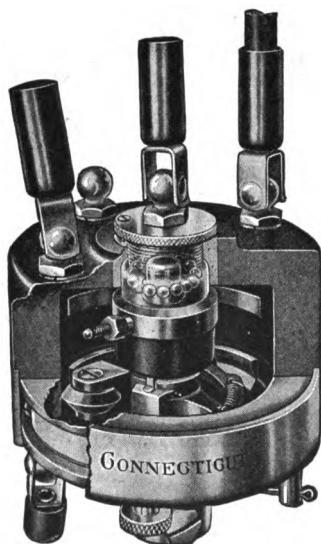

COMBINED TIMER AND DISTRIBUTOR.

Showing rotating timer contact roller in lower part and the distributor contact above. On the bottom is shown the single timer terminal and on top are the high tension terminals, the center one coming from the coil and the outer ones leading to the spark plugs.

after the other in rotation, sends the spark current to the right cylinder at the time the piston is in the firing position. The time at which the spark occurs in the

stroke is governed by the instant at which the breaker points stop the flow of current in the coil, or when the timer causes current to flow, the distributor only serving to send this current to the right cylinder of the engine.

Distributors are used on all magnetos for engines of more than two cylinders; in connection with breakers and single spark systems using a battery current without a magneto and also as a separate unit combined with an ordinary timer in connection with one vibrating coil.

The magneto distributor is described under magnetos.

The wires are attached to the terminals of either type just as directed for the magneto distributor, the piston of one cylinder being brought to the firing position and a wire run from the terminal of the distributor that is making contact through the rotating brush or contact inside the distributor to the spark plug of that cylinder. Inasmuch as the distributor is always used with some form of breaker, timing and setting the breaker brings the distributor into the proper position at the same time.

The center or middle terminal on any form of distributor should be connected to the transformer coil that furnishes the spark current. When a distributor and breaker or timer are made together the distributor part is always farthest from the driving shaft or on top of the timer. The timer or breaker contacts are on the bottom or side or part nearest the driving shaft, the distributor terminals being on top or farthest from the shaft.

The timer or breaker contacts are usually marked

for proper connection. A timer for use with a distributor has only one terminal besides the grounding terminal. In many cases there is no grounding terminal so that the single connection is made from the timer to the low tension terminal on the coil or the switch. In any case this single terminal must be connected in such a way that the primary current from

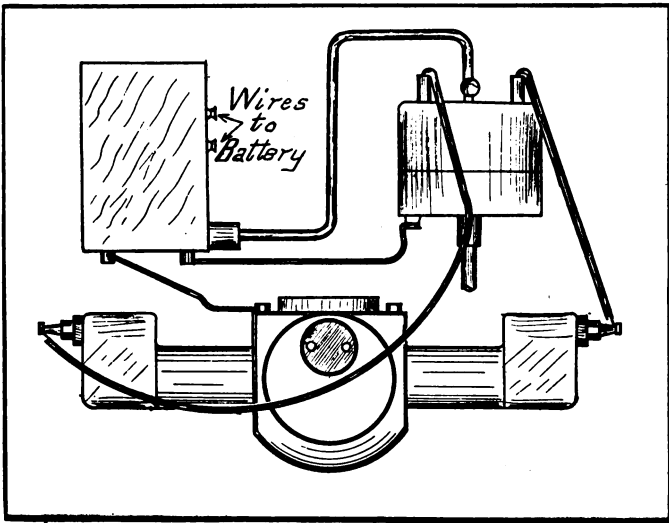

HIGH TENSION DISTRIBUTOR.

the battery flows to it, either before or after this current passes through the coil or switch.

Connections for breakers or single sparkers usually have only two terminals, one for the ground connection and the other for the breaker contact point that is carried on the adjusting screw. To find the breaker contact touch one end of the tester to the metal

IGNITION

of the breaker and the other end of the tester to the terminal to be tested. When you turn the shaft, if the lamp lights and goes out this terminal is the breaker terminal and should be connected to the coil terminal marked "Breaker" or "Int." Most breakers or sparkers have their terminals plainly marked with letters or abbreviations.

The contact brushes and points inside the distributor should be kept clean and smooth and no oil should ever be used at any point inside the distributor, although oil may be used in the timer or breaker.

IGNITION SYSTEMS.

Ignition systems are divided into several types according to the parts used and their arrangement.

Single ignition means a system using a high tension magneto without any batteries or separate coils, the magneto making the spark current without outside help or attachments.

Set spark ignition means a system having no means for advancing or retarding the time of the spark, the breaker being placed in the best position for average running and left there always.

Double ignition means a system including a high tension magneto with or without a coil, this magneto having a set of spark plugs and wires used for the magneto only. In addition to the magneto there is some form of battery ignition system, this battery ignition system having another and entirely separate set of spark plugs and wires. Either system of a double set could be entirely removed without affecting the other system and the engine would still run.

Battery ignition means any ignition using the battery current for running of the engine.

Dual ignition means a system of ignition using a magneto, with or without a coil and in addition a battery and coil. Some parts, usually the breaker, plugs, high tension wires, distributor and switch, being used for both systems so that the complete removal of one entire system would put the other one out of operation. Some forms of dual ignition have separate breakers for the magneto and battery current.

IGNITION

Duplex ignition is a form of dual ignition.

Variable spark ignition is any system having means for advancing and retarding the spark to change the time at which it occurs in the stroke.

Transformer coil ignition is an incorrect name for dual ignition inasmuch as all forms of high tension jump spark ignition use a transformer coil in some form.

Low tension ignition does not use a transformer coil but causes the spark by separating two contacts inside the cylinder, these contacts carrying a current of low voltage and high amperage.

Make and break ignition is low tension ignition.

LOW TENSION IGNITION.

A low tension or make and break ignition system consists of a magneto generating a large volume or amperage of current at from 20 to 30 volts pressure and means for leading this current into the combustion chamber of the cylinder where it passes from a stationary contact point to a movable point.

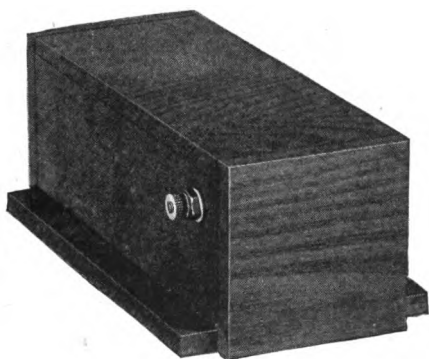

MAKE AND BREAK IGNITION COIL.

This movable point is made to separate from the stationary point producing a bright, hot spark at the moment of breaking.

There is also means for holding these contacts together with a spring and for causing them to separate at the instant the spark is wanted. This system,

has means for changing the time of breaking and of the spark during the stroke.

Some forms use a spark coil to make the current give a larger and hotter spark. This spark coil is not a transformer coil, having only one winding with a terminal at each end of this winding. Causing the current to flow through this coil increases the spark heat and size.

The stationary contact is insulated from the metal of the cylinder by means of a mica or stone bushing and both stationary and moving contacts are carried on a plate that is bolted over a hole in the cylinder, usually over the inlet valve.

The contacts are held together by a light spring and are made to separate quickly when a push rod slips past the sharp end of a small lever arm attached to the moving contact but on the outside of the cylinder.

The advance and retard of the spark is effected by a worm and pin arrangement that shifts the position of the push rod or the contact lever arm.

The operating shaft or push rod receives its power from the valve cam shaft or from another shaft driven from the crank shaft.

Each time the contacts separate there is a spark produced and before another spark can be had the contacts must be brought together long enough for the current to again flow through the circuit.

In order to produce a good spark the break must be made very quickly, more quickly than the ordinary movement of the parts. This is accomplished by having a moving arm operated from an eccentric on top of a shaft, this arm pushing against a lever

which is held against the arm by a spring. The lever and arm are made short enough so that when the arm reaches nearly to the end of its movement the end of the lever trips or slips back and this quick movement causes the break to come suddenly.

The contact points at which the spark occurs must be kept clean and bright at all times by filing or sand-papering them.

The tension of the small spring must be great enough to cause a good firm contact between the points and this contact must be held closed for as long a time as is possible to give the proper current flow.

The insulation must be perfect on all wires, short circuits or grounds will cause the loss of all the current generated.

The moving parts outside the cylinder should be oiled daily with a light machine oil and should be kept clean and free from dirt and dust.

In using a low tension ignition system it is not usually possible to advance the spark timing as fast or as far as with the jump spark system. Before starting the engine the spark must be fully retarded or injury is almost sure to result in cranking.

Although a low tension magneto has no breaker or distributor it must be correctly set so that the break at the contacts comes just as the magneto armature winding is delivering its greatest flow. The break should come when there is a space of about one-fourth inch between the edge of the pole piece attached to the magnet and the metal core of the armature. This space should show or appear on the side of the magneto so that when the magneto is turned still farther

IGNITION

in the direction in which it runs the space gets larger, not smaller. This position is the point at which it is hardest to turn the armature shaft by hand. Trying the magneto by turning by hand will usually give good enough timing if the gears are meshed so that the contacts separate in the cylinder when the armature shaft turns hardest.

On account of the large amperage compared to the jump spark system the wires used should have more copper conductor. They should never be less than a number 12 and should be well insulated.

Common troubles that may be looked for in make and break ignition systems are as follows:

The contact points may be dirty, pitted, sooted or worn away.

The points may not touch for long enough.

The wires may be short circuited or grounded.

Moving parts may stick so that there is no make or break.

Insulation on the stationary contact may be broken, leaking or covered with soot or oil in the cylinder end.

The parts may have slipped so that the spark comes at the wrong time.

The magneto may need remagnetizing of the magnets.

The bushing through which the movable contact is operated may be so worn as to affect the timing or admit air.

The timing or advance and retard is changed by altering the amount of movement or throw of one of the levers. This may be changed in some systems by loosening a lock nut at the top of the shaft that turns

from the cam or gear shaft and then turning the rotating part or eccentric or lever until the points are seen or heard or felt to jump apart. This breaking should come when the flywheel has been turned one inch past the point where the piston is at top center at the end of the compression stroke, with the spark lever in the fully retarded position. The engine should be turned one full turn after the exhaust valve closes and brought so that the piston is at the top of its stroke. Then turn the flywheel about one inch farther in the direction in which it runs. With the locking nuts loose, turn the eccentric or part that moves the trigger or tripping arm in the same way that it turns until the points just separate. Lock the parts in this position.

A low tension system may be changed to a high tension system by boring and threading the hole that held the stationary contact point so that it will take an ordinary spark plug. It is usually easiest to bore the hole and tap it one-half inch standard pipe thread. Replace the magneto with a high tension or dual type of magneto or else place a timer or breaker or single sparker on the old magneto shaft and use a vibrating coil or the coil made for the outfit used. This system can then be wired up and used, neglecting or removing the other make and break parts.

MAGNETOS.

Magnetos generate current in the same way that dynamos act but the magneto has only one coil around its armature, uses no commutator and is built with permanent magnets. Some magnetos really have two parts of this coil wound together on the armature but the outside part is a secondary winding of a transformer coil and does not generate current in the same sense that the primary winding does.

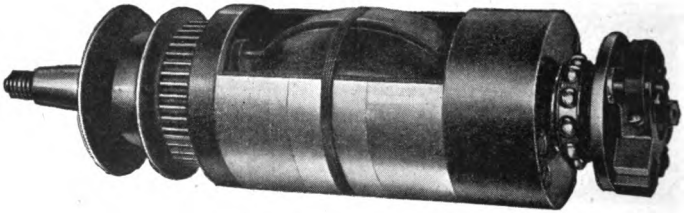

HIGH TENSION MAGNETO ARMATURE.

From right to left showing the breaker, the ball bearing, the case covering the condenser, the coil of wire on the iron core, the gear that drives the distributor, the high tension collector ring and the tapered driving shaft.

The magneto consists of the armature with its low tension winding and a separate transformer coil mounted at some other place on the car, or it may have both primary and secondary windings on the armature. In addition to these parts there is a breaker mounted at one end of the armature shaft and a distributor driven through gears from the armature shaft. Terminals are fastened to the breaker, dis-

tributor and base and also to brushes that collect the high or low tension current from the armature in some machines. These terminals are usually marked so that wires may be run to the corresponding terminals of the coil and switch.

The breaker and distributor always have removable covers for convenience in timing or setting the position of these parts.

Magnetos are driven from any moving shaft and usually have a form of universal joint called an Oldham coupling between the armature shaft and the driving shaft. This Oldham coupling is in three pieces, two pieces that fasten respectively to the end of the driving shaft and to the end of the armature shaft. These pieces have slots cut across their face and the piece that goes between them has projections on each side that fit into these slots. This allows a slight motion and prevents strain on the armature shaft bearings.

A single cylinder magneto should turn at half crank shaft speed, or, if it turns at crank shaft speed, every second spark will come at the end of an exhaust stroke and do no harm.

A two cylinder magneto on an opposed horizontal engine gives a spark in each cylinder at the same time, but, while the spark goes to one cylinder at the end of its compression stroke and fires the charge, the other piston is at the end of its exhaust stroke so that the spark in it does no harm.

A three cylinder magneto should operate at $1\frac{1}{2}$ times crank shaft speed or else it may have two cams in the breaker and operate at only $\frac{3}{4}$ crank shaft speed.

IGNITION

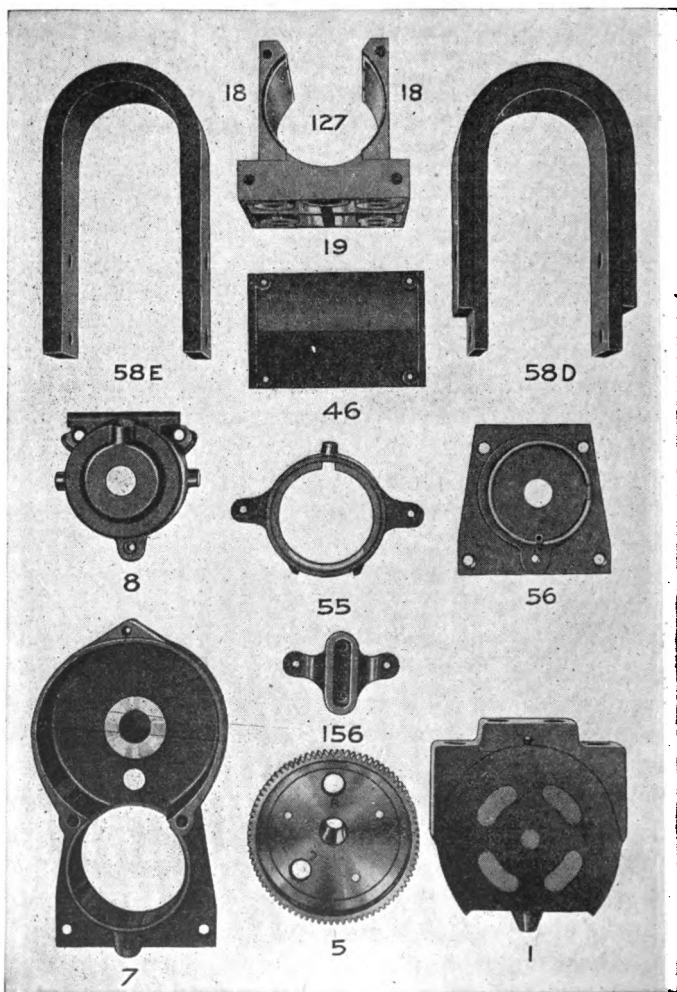

MAGNETO PARTS.

1, Distributor cover; 5, Distributor gear; 7, End plate for breaker and distributor; 8, Armature bearing holder; 18, Pole pieces; 19, Base plate; 46, Armature cover; 55, Breaker case; 56, Rear end plate; 58D, Compound magnet; 58E, Single magnet; 127, Armature tunnel; 156, Distributor brush holder.

IGNITION

A four cylinder magneto has two cams in the breaker and operates at crank shaft speed.

A six cylinder magneto has two cams in the breaker and operates at $1\frac{1}{2}$ times crank shaft speed.

Three, four and six cylinder engine magnetos require a distributor.

For two cycle engines the speed of the magneto must be doubled.

If the magnets must be removed from a permanent magnet magneto first loosen the screws holding them to the pole pieces or base. Then lay a piece of iron or steel from one leg to the other of the magnet and as far down toward the poles as possible. Lift the magnets carefully off while pushing this piece of iron or steel down until it rests from pole to pole. Leave this piece on the magnets all the time they are off the magneto.

If you take two permanent magnets and touch one pole of one to one pole of the other these poles may pull or attract each other. Turn one of the magnets around until you find two poles, one on each magnet, that do not attract each other. These poles, that do not attract each other, must be placed together on the same side of the magneto. If two magnets are placed on a magneto in such a way that they tend to stick together the magneto will not make any current.

As explained under dynamo action the current is generated or induced by causing a change in the lines of force acting through a coil of wire. In the ordinary magneto and dynamo this change is made by turning the armature. There is another type called an inductor magneto or generator in which the coil

and magnets remain stationary and the change of magnetic field is caused by moving the pole pieces or inductors.

This type has U shaped permanent magnets like any other magneto. Carried on a shaft in the same position as the ordinary armature would be carried are two pieces of iron. One piece sticks out from the shaft at one side, near one end, and the other piece sticks out from the shaft at the other end, but directly opposite to the direction the first piece extends so that one piece

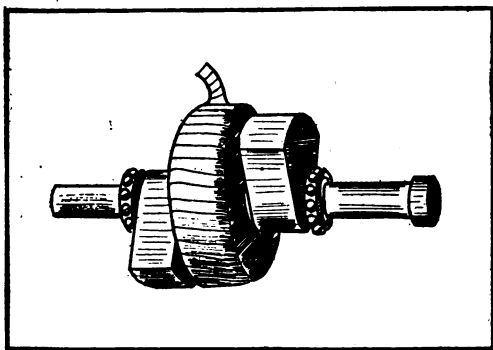

MAGNETO INDUCTORS.

Showing stationary coil mounted around shaft between iron inductors.

sticks out from one side of the shaft and the other from the other side. These pieces extend out from the shaft to a point very close to the magnet poles.

With the shaft in one position the inductor piece at one end of the shaft is near the positive pole of the permanent magnets and the inductor piece at the other end of the shaft is near the negative pole of the magnets. In this position the lines of force will flow from

the positive pole into one inductor, through the shaft to the other inductor and into the negative pole. This makes the lines of force flow through the shaft toward one end because the inductors are about two inches apart on the shaft.

As the shaft is turned the inductor that was near the positive pole comes near the negative and the one that was near the negative comes nearer the positive. The lines of force still flow from the positive to the negative pole, but, as the inductors have changed places, the lines of force flow through the shaft in the other direction.

On the shaft between the two inductors there is a stationary coil of wire through which the shaft passes. It will be seen that the lines of force flow first in one direction through the center of this coil (the center being the shaft) and then reverse and flow in the other direction as the shaft is turned. This causes an induced current to flow in the coil.

The Ford magneto is of a peculiar type of low tension instrument generating from six to twenty-five volts, depending on its speed. The Ford magneto is part of the flywheel and is contained in the case with the transmission at the back of the cylinders and crank case. On the top of the transmission case is a terminal through which the current from the magneto comes, the other end of the winding being grounded inside the case. The current from this terminal is used with a timer and four unit set of vibrating coils in the same way that a battery current would be used.

The Ford magneto is composed of a number of V shaped permanent magnets fastened around the face of the flywheel with their poles pointing toward the

outer edge of the wheel. The negative poles of two adjoining magnets are next to each other and the positive poles of each two adjoining magnets are together. This set of magnets revolves with the flywheel, being driven by the engine. Facing these magnets is an equal number of coils mounted on a stationary part of the transmission case. The ends of the cores of this ring of coils come within $1/32$ nd inch of the poles of the magnets on the flywheel. All the coils are joined together by conductors and when the magnets revolve there is an alternating current produced in the coils which can be used for ignition or lighting but not for storage battery charging.

A permanent magnet magneto will lose some of its power if mounted on a base or plate of iron or steel. Iron or steel will carry the magnetism from one pole to the other without the magnetism passing through the armature or coils. Any other material except iron or steel may be used for magneto bases.

There may sometimes be sufficient play or lost motion in the shafts, gears or couplings that drive the magneto to make a serious difference in the timing of the spark. Play in these parts or in the chains driving the magneto shaft may cause overheating, loss of power, missing and irregular running of the engine. The play should be removed and with it will often go many troubles hard to locate.

All standard forms of separate magnetos should have about two or three drops of light machine oil dropped into the holes on the magneto about once a month. There are usually two holes or sets of holes either covered or open, one set being at one end of the magneto and the other set at the other end. There

may only be one set at one place, tubes leading from here to the parts to be oiled. Never oil the distributor and do not give more oil than directed above unless there are directions on or with the magneto that give other instructions.

Magneto Troubles.

1. Breaker points pitted or worn. Dress with a fine file.
2. Breaker points separated too far. Adjust so they will open the thickness of a thin card.
3. Breaker points not separating. Adjust as above.
4. Loose parts in breaker. Adjust and tighten.
5. Breaker arm sticking. Take off and adjust by smoothing with sandpaper.
6. Brushes dirty. Smooth with sandpaper.
7. Brushes broken. Replace with new ones.
8. Brushes sticking or binding. Clean with sandpaper or gasoline.
9. Broken brush springs. Replace with new ones.
10. Magnets on wrong. Magnets must be on the magneto with both negative poles on one side and both positive poles on the opposite side. The poles that try to keep away from each other must be put together.
11. Magnets weak. Must be remagnetized.

Magneto Timing (Armature Position). The armature of the magneto should be set, relative to the breaker, so that the greatest flow of current comes just as the breaker points cause the flow of current to stop passing through the armature coil. In most magnetos, this is the time at which the points separate, although magnetos have been built in which the current stops flowing through the armature coils when the points come together. This is accomplished by

connecting the points in such a way that when they are open the current has to flow through the coil but when the points come together they provide a path of less resistance than the coil so that there is no further flow through the coil. However, the great majority of magnetos have the ends of the winding on the coil connected to the breaker points so that when the breaker separates the current stops flowing in the coil and produces a spark in the secondary winding.

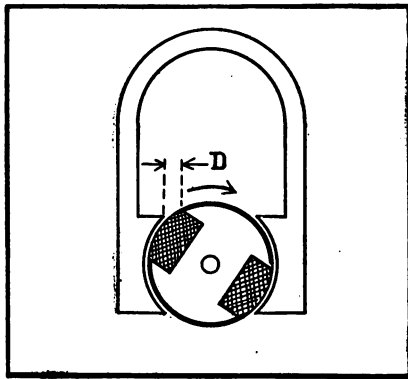

ARMATURE POSITION,
D, Gap between edge of pole piece and edge of armature core.

The armature and breaker require different setting relative to the distributor according to whether the armature rotates clockwise or anticlockwise. The direction of armature rotation is always taken from the drive end of the armature shaft. To decide which way the armature turns look at the shaft from the drive end and if it goes right handed or the same way the hands of the clock move it is a clockwise magneto,

if it goes lefthanded or the opposite way from the direction the hands of the clock move it is an anti-clockwise magneto.

The breaker itself may usually be changed for either direction of rotation by changing the cam or the movable arm. Removing either of these parts and turning them over before replacing will allow the magneto to rotate the opposite way. In many magnetos there are small arrows on these parts indicating which way the shaft should turn. Some magnetos are built in such a way that the direction of rotation cannot be changed outside the factory.

It may also be possible to remove the pins or screws that limit the breaker box movement and place them in a new position at which the points open at the correct time.

The distributor is properly set by changing the mesh of the gears between the distributor and the armature shaft.

To find the proper point at which the breaker points should cause the current to stop flowing in the armature coil, usually the time of breaking, remove the cover that is over the top of the armature between the magnets. The two pieces of metal that are fastened to the ends of the magnets are called pole pieces and fill up most of the space between the magnets and armature.

You will notice that the armature is made from a piece of iron around which is wound a coil of wire. This iron is between the pole pieces whenever the coil can be seen. As the armature is turned the coil disappears and more of the iron of the armature comes into view. Keep turning the armature in the direc-

tion it should run until the part of the iron that you can see extends from pole piece to pole piece and so that none of the coil can be seen.

If you are turning the armature clockwise the iron will then leave the left hand pole piece first; if you are turning it anticlockwise the iron will leave the right hand pole piece first.

When the iron of the armature has left the edge of the pole piece enough to show about one-eighth of an inch gap between the edge of the pole piece and the edge of the iron of the armature, the breaker should open or stop the current flow.

While making this test the breaker or spark timing lever should be as far advanced as possible, that is the movable part of the breaker or cover should be turned as far as possible in the opposite direction to which the shaft turns.

With the breaker points just opening or stopping the flow of current the gears between the distributor and armature shaft should be placed in mesh so that the moving brush or contact on the distributor is just starting to make contact with any one of the segments or collecting brushes that carry the current to a spark plug wire. This moving brush or contact should then move farther over the stationary brush or contact as the armature is turned in the direction it should run. This test should be made with the spark fully advanced.

Magneto Timing (Breaker). 1st. Turn the crank shaft by means of the hand crank or flywheel until the exhaust valve on number one cylinder (next the radiator) just closes.

2d. Turn the crank or flywheel just one even turn from this point which will bring the piston just a little ways down on the firing stroke.

3d. Set the breaker case and spark lever in the fully retarded position by turning the breaker case just as far as it will go in the same direction that the armature shaft revolves and be sure that it remains in this position while timing.

4th. Turn the magneto armature shaft in the same direction that it runs until the breaker points just separate and then mesh the gear on the end of the armature shaft with the gear that drives it from the crank

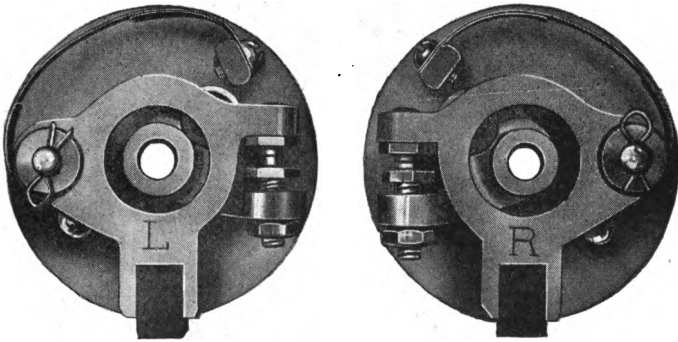

MAGNETO BREAKER.

At the bottom is seen the fibre point that strikes against the cams in the case, causing the points to separate.

shaft while the armature, breaker and piston are in the positions given. If the gears (or sprockets in a chain driven magneto) will not mesh in exactly this position turn the armature backwards just enough for the gears or sprockets to mesh.

Magneto Timing (Distributor Wiring). 1st. After timing the breaker and without moving anything about the engine or magneto that has been timed, remove the distributor cover and notice which segment

IGNITION

or brush the moving contact is touching. Run a wire from the terminal on the outside of the distributor that is connected with this contact to the spark plug

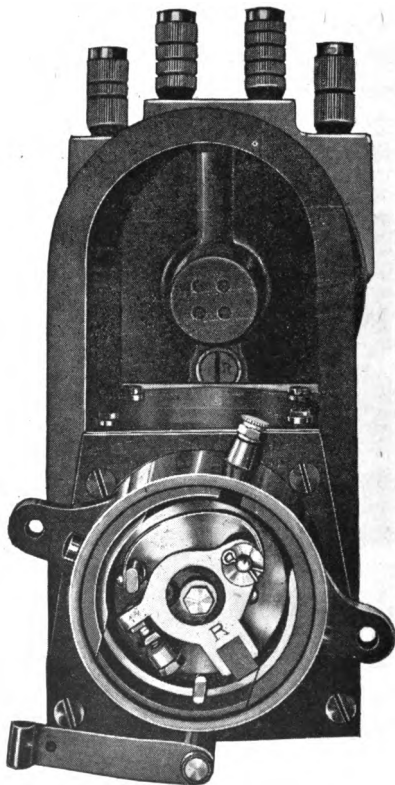

MAGNETO WITH BREAKER COVER REMOVED.

of number one cylinder. If there is any doubt as to which contact on the outside of the distributor connects with the movable brush at this time test them

with the tester by touching the ends of the test wires to the inside and outside contacts of the distributor until you find which ones are connected together.

If, for any reason, it is desired to attach the wires from the distributor to the spark plugs when the magneto is already mounted and timed it is only necessary

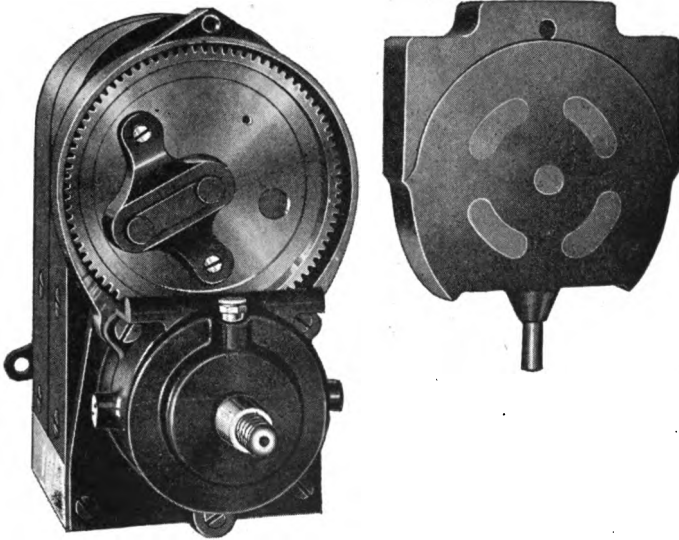

MAGNETO WITH DISTRIBUTOR COVER REMOVED.

Showing the revolving contact brushes carried on the distributor gear. At the right is the cover carrying the segments with which the brushes make contact.

to bring the piston so it is starting down on the power stroke as described above.

2d. Turn the engine until the exhaust valve on number two cylinder just closes, then give it one more full turn from this point.

IGNITION

3d. Examine the distributor once more, without disturbing the spark plug wire already placed, and connect the terminal of the segment or brush now making contact with the moving contact, with the spark plug of number two cylinder.

4th. Do the same with the remaining cylinders as was done with cylinders number one and two.

If you find the firing order of the engine and then watch to see which way the movable part of the distributor revolves, it is only necessary to attach number one spark plug wire and then place the wire for the next cylinder to fire on the distributor terminal next to make contact as the magneto turns in its right direction. All of the spark plug wires may be placed after number one by connecting the wires from the cylinders in regular firing order to the distributor terminals in the order in which they make contact.

The Bosch magneto, Model NU4 has its distributor and high tension terminals on the drive end of the armature shaft. Two terminals are on each side of the shaft, the sets being directly opposite each other.

After timing the magneto according to the breaker as with any other type, attach the spark plug wires from cylinders 1 and 3 to the two terminals on one side, placing No. 1 next the magnets. Place the spark plug wires from cylinders 2 and 4 on the opposite side of the armature shaft with No. 2 wire next the magnets.

Crank the engine, and if it will not run, place No. 1 wire where you now have No. 3, and No. 3 where you have No. 1. Interchange wires No. 2 and 4 in the same way and the engine will fire correctly.

Magneto Wiring. It appears that each make and type of magneto is wired in a way different from all the others, yet these types may be divided into several classes and general rules given for wiring any of them.

These rules will be correct in almost every case, but there may be some systems to which these rules will not exactly apply because some makers introduce peculiar or patented features.

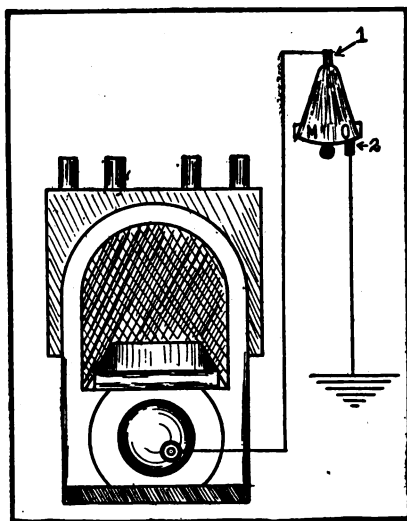

SINGLE OR DOUBLE IGNITION WIRING.

Even in these cases it will be possible to place all the wires correctly except one or two and their positions may be found by testing them on the remaining terminals until the spark is satisfactory.

Magneto ignition systems may be classified under four headings:

IGNITION

(1) True high tension magnetos (magnetos having a secondary winding on the armature so that they deliver a high tension current without the use of outside coils) used for single ignition.

This system consists only of the magneto and a switch.

The magneto has as many distributor terminals as there are cylinders and it has one other terminal on or near the breaker cover.

The switch has two terminals, one being connected to the terminal on the magneto breaker cover and the other being grounded or connected to a metal part of the car.

(2) True high tension magnetos used for double ignition (system in which the magneto and battery systems have only the switch in common).

This system consists only of the magneto, which has as many distributor terminals as there are cylinders and also one other terminal on or near the breaker cover, this terminal being led to the switch.

The switch may be mounted separately but will probably be on the battery coil. This switch may have several terminals and to find the one to be connected to the magneto turn the switch to the "Off" position and find two terminals that have a complete connection between them inside the switch but that break this connection when the switch is placed in the "Magneto Position." One of these terminals is to be connected to the terminal on the magneto and the other to the ground or frame or metal of the car.

(Whenever it is desired to locate two terminals that make a connection inside of a switch or coil box it may be done by touching one wire of the tester to any ter-

minal and then touching the other wire to the other terminals until some combination is found that lights the lamp or moves the meter hand when the connection should be made complete, then puts the lamp out or lets the meter hand come to zero when the connection should be broken, as when the switch handle is

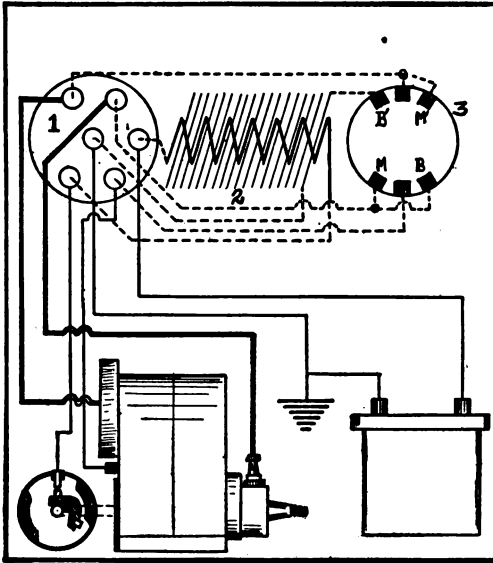

HIGH TENSION MAGNETO WITH SEPARATE BATTERY COIL.

1, Engine end of coil with terminals; 2, Coil windings; 3, Switch on coil: B'-B contacts connected with switch in "Battery" position; M'-M contacts connected for "Magneto" position; Dotted lines indicate wires running inside coil case.

moved one way or the other as directed for each case.)

(3) True high tension magnetos used in connection with a separate coil, this separate coil being used to transform the battery current only, the magneto current being made high tension in the armature.

IGNITION

This system consists of the magneto and a separate coil, the coil carrying the switch mounted on it, or, in some types the switch and coil may be separate from each other.

The magneto distributor may have just as many terminals as there are cylinders or it may have one more than this number of terminals. If the coil has six terminals the distributor will have one extra terminal; if the coil has only four terminals then the distributor will have no extra terminals.

If the coil has four terminals there will be three terminals on or near the breaker box cover of the magneto. One of these connects with the positive terminal on the battery and the other two with the coil.

If the coil has six terminals there will be two terminals on or near the breaker cover and in the other end of the magneto, back of the magnets and directly above the armature shaft will be found another terminal. All terminals on the magneto are connected to the coil.

With the four terminal coil make the connections as follows: Disconnect all wires from the magneto except spark plug wires and start the engine. With a wire touching the frame of the car or magneto touch the terminals on or near the breaker box until you touch one that stops the engine and mark this one. With the coil switch in the "Off" position find two terminals on the coil that connect together but that break the connection when the switch is placed in the "Magneto" position. Connect one of these to the magneto terminal just marked and ground the other one. Now turn the switch to the "Battery" position

and touch one of the tester wires to one of the remaining terminals on the magneto and to one terminal on the coil. Find one coil terminal and one magneto terminal that complete the circuit but that break it when the switch is turned back to "Off." Connect this magneto terminal to the positive terminal of the battery and this coil terminal to the negative terminal of the battery. This leaves one terminal on the magneto and one on the battery which are to be connected together.

With the six terminal coil make the connections as follows: Touch the fingers from the terminal over the armature shaft at the back end of the magneto to the magnets and turn the magneto by hand. If a slight shock is felt this is the high tension collector terminal, if no shock is felt try other terminals in the same way until a shock is felt. Now turn the switch to the magneto position and find two terminals on the coil that make a circuit but break it with the switch in the off position. Connect one of these terminals to the high tension collector terminal on the magneto (which was just found) and connect the other to the extra center terminal of the distributor. Now remove all wires from the magneto except the one just placed and the spark plug wires, place the switch in the magneto position and start the engine. With a piece of wire that is connected to the frame touch the magneto terminals around the breaker one after another until one is touched that causes the engine to stop, and mark this terminal. Turn the switch to the off position and find two of the remaining terminals that make a circuit in the off or the battery position but that break the circuit when the switch is in the

magneto position. Connect one of these coil terminals to the terminal that was just marked on the magneto and ground the other coil terminal. This leaves one terminal on or near the magneto breaker cover, two on the coil and two on the battery. Ground one of the battery terminals and connect the other one to either of the coil terminals. Now connect the remaining coil terminal to the remaining magneto terminal. The last two connections made on the coil may have to be reversed to secure a satisfactory spark.

(4) Low tension magneto system having only a primary winding on the magneto armature and using a separate coil for transforming both the magneto and battery current to high tension. Usually called a dual or transformer coil system.

This system consists of the magneto with a separate coil and a separate switch; or of the magneto with a separate coil and switch, the coil and switch carried in one case.

The distributor has one more terminal than there are cylinders and there are three terminals on or near the breaker cover or else there are two terminals at this point and one at the other end of the magneto over the armature shaft or at one side of it. The last three mentioned are low tension terminals, one being grounded directly to the frame of the magneto, another being fastened to the stationary contact of the breaker and the third leading from the armature winding. The other end of the armature winding and the movable contact of the breaker are grounded inside the magneto.

It will first be necessary to find which of the low tension magneto terminals is which. First touch one

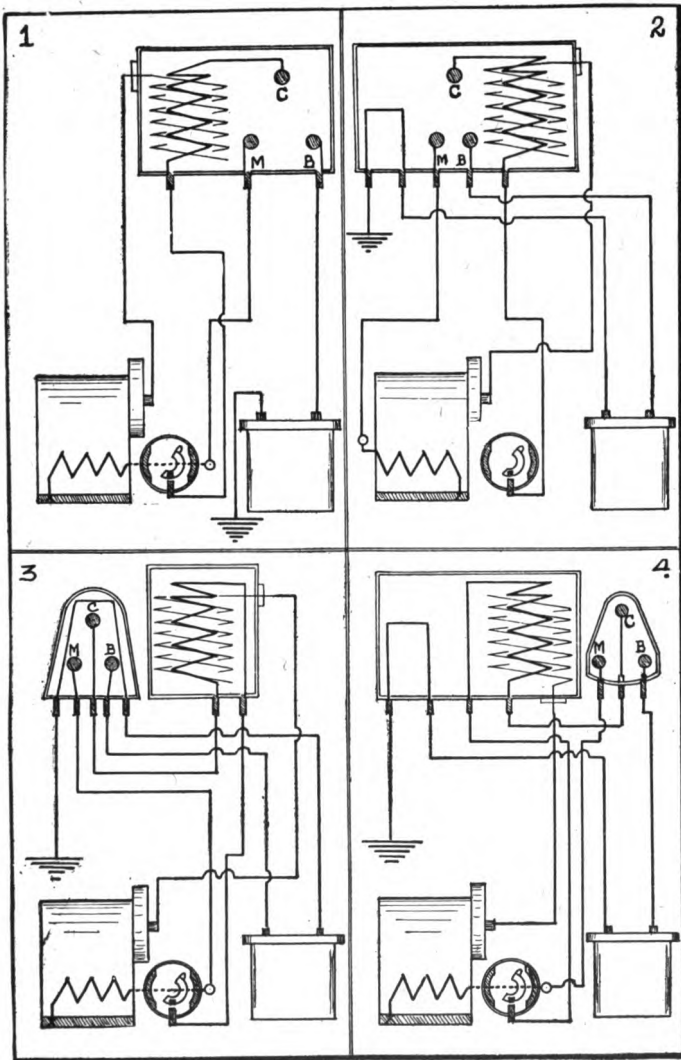

LOW TENSION (DUAL) WIRING SYSTEMS.

1, Coil and switch in one case, three low tension terminals; 2, Coil and switch in one case, five low tension terminals; 3, Coil and switch separate, five switch terminals, two coil terminals; 4, Coil and switch separate, three switch terminals, four coil terminals; C, Common switch connection; B, Battery connection completed through C; M, Magneto connection completed through C.

IGNITION

end of the tester wire to the frame of the machine and the other end to a terminal that causes the circuit to be made and broken as the armature shaft is turned. This is the breaker or interrupter contact and is often marked "Int." One of the remaining two magneto terminals will be fastened solidly to the frame of the magneto, the third being set in an insulated bushing of some kind, either in the center of the breaker cover, at the rear end of the magneto or at one side of the breaker cover. No matter where this last terminal is located it may be easily recognized because it is insulated. This insulated terminal is the one coming from the armature winding and is called the magneto or armature wire and is often marked "Mag" or "A." The remaining terminal, which can be recognized because it is fastened tight to the frame of the machine at some point is the ground terminal and may be marked "Grd" or "M."

This system may use a coil and switch in the same case and there may be either four or six terminals on the coil. If there are four terminals on the coil one side of the battery is grounded. If there are six, one side of the battery is run to one coil terminal and the other side of the battery to another coil terminal. The largest and heaviest insulated terminal on the coil is high tension and should be connected to the extra terminal on the distributor.

If there are three terminals after connecting the high tension, ground one side of the battery by running a wire from the battery to the ground terminal on the magneto. Now turn the switch to the battery position and find the two terminals that make a circuit but that break it when the switch is in any other posi-

tion and mark these terminals (we will say they are marked red). Now turn the switch to the magneto position and find two terminals that complete the circuit but break it when the switch is turned from the magneto position. Mark these two terminals also (we will say they are marked blue). Now connect the coil terminal that has both a red and blue mark to the breaker terminal on the magneto, connect the terminal marked red only to the remaining battery terminal and the one marked blue only to the armature or magneto terminal on the magneto. If there were

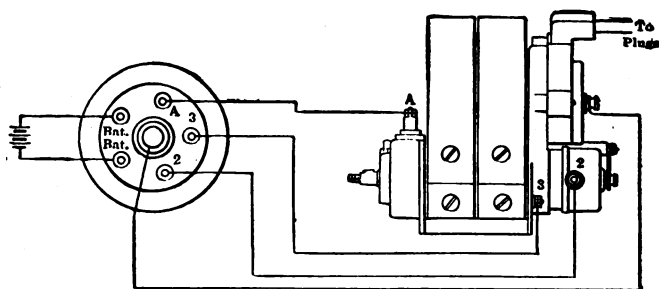

WIRING OF MAGNETO WITH DASH COIL. (Splitdorf.)

five terminals after connecting the high tension to the distributor find two terminals that make a circuit all the time no matter what position the switch is in. Connect one of these terminals to one side of the battery and the other one to the ground terminal on the magneto. This leaves three terminals which are connected in the same way that the three terminals mentioned above were connected.

If the coil is separate from both the magneto and the switch it may have either three or five terminals, de-

pending on whether the battery is grounded or not grounded, respectively. In either case the largest and heaviest terminal is the high tension and should be connected to the extra terminal on the distributor.

If this leaves two terminals on the coil either one is to be connected to the breaker terminal on the magneto and the other one to the switch. Connect one to the breaker and the following instructions will tell which switch terminal to use.

If there are four terminals on the coil box after connecting the high tension, touch the ends of the tester to two of them at the same time until you find the two that light the lamp the brightest or show the greatest flow through an ammeter. Connect one of these to one of the battery terminals and the other one to the ground terminal on the magneto. This leaves two terminals on the coil and either one may be connected to the breaker terminal of the magneto, the other one being connected to the switch as directed below :

When the coil is separate there will of course be a separate switch with either three or five terminals on this switch. If there are five terminals find two of them that always make a complete circuit no matter in what position the switch is placed. Connect one of these terminals to the battery terminal not grounded or connected to the coil and connect the other one of these two terminals to the ground terminal on the magneto. Now turn the switch to the battery position and find two terminals that complete the circuit but that break it when the switch is moved from the battery position. Mark these two terminals red. Now move the switch to the magneto position and find two terminals that make a circuit when the switch is this

way but that break the connection when the switch is moved and mark these two blue. Connect the terminal that has both a red and a blue mark to the terminal of the coil mentioned above that was connected to the switch, connect the terminal with the red mark only to the remaining terminal of the battery and connect the one with the blue mark only to the armature terminal of the magneto.

If the switch has only three terminals it will only be necessary to test for the terminals that were marked red and blue, the others not being on the switch.

It should be remembered that the above instructions will not take care of every case and that it is always best to proceed according to the markings on the magneto, coil and switch when there are any markings to go by. If you have a wiring diagram it is best to use it, but if you do not get the proper results you can perform the above tests and make the connections accordingly.

SINGLE SPARK BATTERY IGNITION.

Single sparkers are really a form of breaker used in connection with a battery and transformer coil for ignition.

They differ from the vibrator used with some coils in that they are carried in a separate case like a timer and are mounted on the end of some shaft that turns at the same speed as a magneto shaft would turn for the same engine. They are operated by cams and produce only one spark at each ignition point. They act in somewhat the same way as the breaker of a magneto except that by using a special form of cam and spring the break is made extremely quick, producing a powerful, hot spark with very little battery current consumption. The best known makes are the Atwater Kent and the Briggs and Stratton.

The adjustment and care required are the same as for magneto breakers, the adjustment being secured by turning one of the platinum contact points closer to, or farther from, the other one. The adjustable point is carried on the end of a screw which may be turned either way.

Should the sparker refuse to spark properly the most probable cause of trouble is that the contacts are dirty, worn, pitted, rough, or, that they do not meet each other squarely. They should be carefully dressed with a small flat file so that the points are clean and meet each other smoothly.

After dressing them the points should never touch

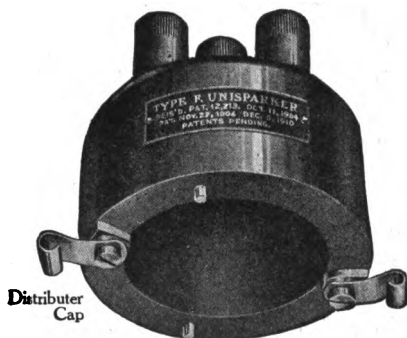

Distributor
Cap

Distributor
Block

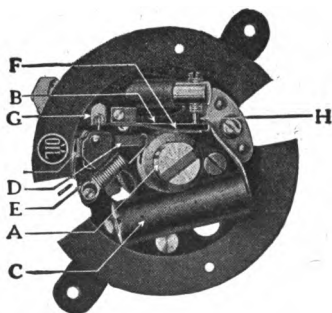

Fig. 11.—Contact maker disassembled.

- | | |
|-------------------|-----------------------|
| A—Notched Shaft. | E—Lifter Spring. |
| B—Contact Spring. | F—Contact Arm. |
| C—Condenser. | G—Contact Arm Spring. |
| D—Lifter. | H—Contact Screw. |

UNISPARKER.

each other when the engine is idle and the gap between the points should be from $1/64$ th to $1/32$ nd inch. The smaller the gap the more battery current will be used but the spark will be hotter. The points should be separated as much as possible and still allow the spark-er to operate properly.

Should the batteries become weak the engine may be made to run for a short time by screwing the points nearer together.

A single spark-er is mounted on a revolving shaft and fastened by set screws in such a position that a spark is produced just after the piston starts down on the firing or power stroke with the spark-er moved as far as possible in the same direction that the shaft runs, in other words, retarded.

Single spark-ers come complete with their coil and with a distributor mounted on the spark-er if the engine has more than two cylinders. The coil is usually mounted on the dash of the car and may carry the switch. The wiring is done according to the marks at the terminals of each part.

SPARK ADVANCE AND RETARD.

It would seem that a flame travels exceedingly fast, yet the flame through the gasoline vapor in the cylinder travels slowly compared to the speed of the piston when the engine is running fast. For this reason it is necessary to make the spark pass between the points of the spark plug before the piston has come to the top of its stroke if the engine is running fast. By the time the flame spreads from the end of the plug through the gas and has produced the pressure to drive the piston down on the power stroke, the piston will have come to the top of its stroke. If the spark was not advanced enough the piston will have already started down again.

Means are always provided for causing the spark to pass at the plug earlier in the stroke, this being adjustable by the driver while the engine is running in most cases though not adjustable by the driver in other types.

Whenever there is means for changing the time of the spark it must be caused to come late in the stroke when the engine is being cranked by hand to avoid danger of the piston starting back the wrong way and injuring the operator. To retard the spark in this way it is necessary to turn the timer, magneto breaker, single sparker or distributor in the same way that their driving shaft turns just as far as the levers will allow them to go.

In setting these devices they should cause the spark

IGNITION

to come just after the piston starts down on the power stroke when the instrument is fully retarded as described above.

The single exception to this rule is with a true high tension magneto with which the engine may easily be started by cranking rapidly with the switch in the magneto position, making it unnecessary to use the battery system even for starting. In this case the spark lever should be advanced more than half way and almost two-thirds of its whole travel.

There is no danger of a back kick for the reason that no spark will be generated in the magneto until the crank shaft speed is great enough to carry the piston over top center and down onto the power stroke.

Set spark systems have no way for the driver to change the advance or retard of the spark while running. This system is only used when a high tension magneto is the only means of ignition, it would not be safe with battery ignition of any kind. There is no arm on the breaker and the breaker cover will not turn around the armature shaft. This type of magneto should be set to cause the points to separate and the spark to occur when the piston is coming up on the compression stroke and from fifteen to thirty degrees (on the flywheel) before the piston reaches top center.

The slow burning of the gas in the cylinder has caused several makers to adopt the Two Spark Ignition system in which two separate sparks are caused in different places in the cylinder at exactly the same time so that the flame may start from two places at the same time and complete the ignition quicker.

SPARK GAP.

Safety. Should the spark plug wire become loose or broken while the spark current is being generated in the secondary winding of any transformer coil this high voltage current does its best to escape in some way. This may break through the insulation of the wires in the coil and put the coil out of business.

It is not safe to make a spark jump a space in the air of more than one-fourth to three-eighths of an inch, anything more than this may cause the current to break through the insulation inside the coil. To prevent damage to the coil in such cases all high tension magnetos and many single unit non-vibrating transformer coils are equipped with a safety spark gap. This consists of two points separated by about one-fourth to three-eighths of an inch, one point being grounded and the other one connected to the high tension circuit. In case one of the high tension wires should become disconnected the current will jump this gap and escape to the frame without doing any damage.

On a coil the safety gap is usually on the top or at one end, on a high tension magneto the safety gap will be connected to the bar or wire going from the high tension collector terminal.

Never, under any conditions, alter a safety gap in any way.

Auxiliary. It is claimed that a dirty or sooted plug may be caused to spark properly if the wire leading to the plug is separated from the end of the plug by about

IGNITION

one-sixteenth inch, causing the spark to jump this outside gap before jumping the gap between the spark plug points.

The theory is that the current gradually escapes in a dirty plug by leaking along the coat of soot that covers the insulation. This gradual escape lowers the voltage of the current so that it cannot jump the spark gap in the plug at the proper time.

By having an outside gap it is claimed that the current is held back and prevented from flowing by this extra gap until its voltage becomes so high that it is forced across the spark plug points, not taking time to leak over the soot.

Auxiliary spark gaps are made in permanent form and sold by supply houses for attachment to the plugs. They are composed of two points separated by one-sixteenth inch and enclosed in a small glass or mica tube. This tube is closed at each end and has means for fastening to the plug and to the wire.

An auxiliary gap is very handy in locating missing, as it shows positively when the spark is passing in any plug.

SPARK PLUGS.

The ordinary spark plug consists of a short steel tube or shell which is threaded on the outside so that it may be screwed into the cylinder or valve cap. A wire carries the current down through the center of the plug, this wire (called the central electrode) is carried in an insulating bushing made from porcelain, stone or mica. This insulating bushing fits into the outside shell and is made a gas tight fit by packing the joint with asbestos cord or a copper asbestos gasket. The gaskets are held tight and the insulation is kept in place by a small packing nut around the insulation. This nut screws into the top of the shell.

In cleaning a plug it is best, if possible, to unscrew this packing nut, being very careful not to break the insulation, and then remove the insulating bushing which carries the central electrode. The surface of the insulation may then be wiped with a cloth dampened in gasoline or may be rubbed clean with a stiff brush. The insulation must be clean both above and below the place where it passes through the shell. The sparking points should be cleaned with a small file or piece of emery cloth.

In putting a plug back together make sure that after it is assembled the points across which the spark jumps are apart the thickness of a dime for battery ignition and the thickness of a business card for magneto ignition. It is a mistake to suppose that a stronger spark is produced by having the points farther apart, just

IGNITION

the reverse being true. Screw the packing nut just tight enough to make a good joint; screwing it tighter will make porcelain insulation crack as soon as the engine heats up. Make sure that the small lock nut and washer at the top of the central electrode is screwed tight because this prevents the electrode from getting out of place after adjusted. If the plug has a rather coarse tapered thread it is not necessary to use any gasket or packing when screwing it into the engine, but



SPARK PLUG—HALF-INCH THREAD.

Showing terminal nut at top with locking nut under it, also packing nut at top of shell for taking the plug apart.

if the plug has a straight thread, with more threads to the inch, a copper asbestos gasket must be placed so that it comes between the edge of the plug hole and the flange around the shell just above the threads. Plugs are made with three different threads, one-half inch standard, A. L. A. M. standard and metric. Always make sure that the plug is the right size for the hole you are placing it in.

Porcelain is the commonest insulation and the cheapest. Its greatest fault is that it cracks comparatively easily under heat or if hit. It is very durable, outside of these points and is easily cleaned when sooted.

Mica forms an insulation almost unaffected by accidental blows or extreme heat, the greatest objection being that oil finally works through between the layers of mica and forms a short circuit for the spark current.

Stone or lava makes a very durable and almost in-



SPARK PLUG WITH A. L. A. M. STANDARD THREAD.

destructible insulation, but little affected by heat, oil or accident.

Two or more of these insulating materials are often used in combination, one being outside or above or below the other.

There are countless designs and types of plugs on the market but they may all be classified according to the thread, the insulation and the length of the shell.

The $\frac{1}{2}$ inch standard thread is an ordinary tapered

pipe thread cut on the outside of a tube or pipe having a $\frac{1}{2}$ inch inside diameter. There are fourteen threads to the inch, a taper of $\frac{3}{4}$ inch to the foot, the outside diameter being $\frac{84}{100}$ ths of an inch. It is the only tapered thread in use and may be easily recognized in this way.

The A. L. A. M. standard is often called a $\frac{7}{8}$ -18 plug because of the fact that the threads are cut on the outside of a tube having an outside diameter of $\frac{7}{8}$ ths inch and has 18 threads to the inch. It has no taper.

A metric thread is cut on the outside of a tube having an outside diameter of $\frac{1}{2}$ inch with the number of threads measured according to the metric system. It is seldom found except in a few motorcycles and the oldest American cars and in foreign makes.

Sometimes the distance from the outside of the cylinder or cap into which the plug is screwed to the combustion chamber is greater than with other types. The points across which the spark jumps, should extend into, or at least to, the combustion space and to make this possible plugs are made in four lengths. The ordinary plug, which is delivered unless ordered otherwise, has a shell about one inch long in the thread. This fits the majority of engines. A short plug has only about $\frac{1}{2}$ inch of thread, a long plug has about $1\frac{1}{2}$ inch screwing into the cylinder and an extra long plug has an extension about 2 inches below the thread.

Spark plugs may be located in the valve caps, in the side of the cylinder wall or in the cylinder head. The valve cap is the commonest location. When the valve cap is used it is customary to place the plug most used (usually the magneto) over the inlet valve where it receives the fresh gas, although many engines will

throttle slower if the plug is over the exhaust. The plug over the exhaust soots easier than the one over the inlet and if the plug that is used is placed here its continual firing tends to keep it clean, but if the idle plug is over the exhaust there is nothing to prevent its sooting to such an extent that it will not work when wanted.

A new form of plug has been marketed that makes it possible to use two plugs in each cylinder both sparking at the same time from one spark source. This gives many of the advantages of the two spark ignition without its expense.

The old plug is left in place but its wire is removed. The special two point plug is made with two electrodes passing through the insulation in place of only one as in the ordinary plug. There are two terminals on top of the plug, one for each electrode. The spark wire is fastened to one of these terminals and then a short wire is fastened from the other terminal to the top of the old plug. The spark will now come to the special plug, down through one electrode and jump the gap to the other electrode. It will then pass up the other electrode and across the short wire and through the old plug and to the ground. This causes two sparks at the same time, the sooting or short circuiting of one plug having little effect on the other, although the added resistance of the extra gap requires that the points be close together in both plugs.

Spark plugs are made in many special forms, among them being plugs with a priming cup and pet cock in the shell. An engine without means for placing liquid gasoline in the cylinder for easy starting may have these plugs fitted so that the engine may be primed with gasoline for starting.

Other forms of plugs are made to be easily removed for cleaning by having a special thread and a handle so that by twisting the handle a quarter or half turn the center of the plug may be taken out.

Spark Plug Troubles.

1. Points have dirt, oil, or water between them. Clean with emery cloth.

2. Points too far apart. With magneto ignition the points should be the thickness of a business card apart, with batteries the thickness of a dime.

3. Points burned off. Clean and adjust.

4. Points touching. Separate as told above.

5. Points ash-colored. Clean with emery cloth.

6. Points loose. New plug.

7. Insulation dirty. Clean with gasoline and a cloth, or with a wire brush, or by soaking in acetic acid.

8. Porcelain cracked. New porcelain.

9. Mica insulation oil-soaked. New mica core.

10. Insulation core loose in the shell. Tighten the packing nut slightly.

11. Insulation wet, or covered with grease or paint. Must be clean and dry.

TWO SPARK IGNITION.

On account of the slow burning of the gas in the cylinder as explained under Spark Advance and Retard several magnetos have been made which have a double distributor, that is, there are two parts to the distributor, each part having enough terminals so that a wire may be run to each cylinder. There are two

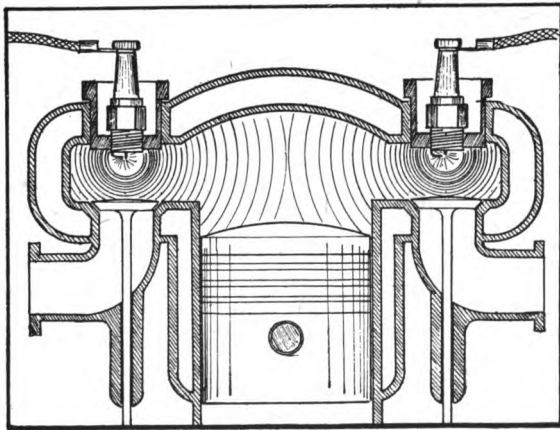

EFFECT OF TWO SPARK IGNITION.

plugs in each cylinder, a wire from each distributor being run to each cylinder, one to one plug and the other to the other plug.

This magneto is wired in the ordinary way as far as the primary wiring is concerned, but there will be a

wire running from one high tension collector (there being two collectors on this type of magneto) to a switch on the dash and from this switch back to the extra terminal on one of the distributors. The other collector is connected directly to its distributor. This makes it possible to run with either one or two sparks occurring in each cylinder by throwing the switch from a point marked "1" to a point "2." The magneto has a terminal on or near the breaker that is connected to the ground through the same switch when this switch is in the off position. This stops the magneto from generating current.

A car fitted with two spark ignition should be cranked with only one spark, that is, with the switch on the "1" point. To secure more speed or power turn the switch to the "2" point, but with two sparks occurring in the cylinder the spark can be carried only about half as far advanced as with one spark and in many cases the spark must be kept retarded until the engine is running at speed.

TIMER OR COMMUTATOR.

A device for sending the primary current to a coil at the right time so that the coil will send its high tension current to the right cylinder at the right time.

A timer is made with a rotating arm or roller inside of a circular shell, this shell being made from insulating material and having brass segments or contacts set

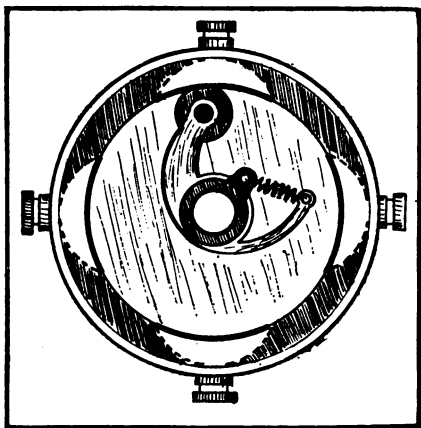

FOUR UNIT TIMER.

into the insulation and connected to terminals on the outside of the timer. There are as many contacts and outside terminals as there are cylinders to be fired.

The rotating arm or roller is fastened to and turned by a shaft running at half crank shaft speed so that

the roller or arm comes onto the contacts one after the other while the engine is running.

Timers are used in connection with battery ignition and in the case of the plain timer as described there will be as many separate coils (either with or without vibrators) as there are cylinders to be fired. When the timer is combined with a distributor there will only be one coil but there will be as many contacts inside the timer as there are cylinders to be fired. In the distributor and timer combined all these contacts are fastened together so that they deliver current from the moving arm into the same wire, the contacts being carried in insulation and separated from each other so that the spark will not be continuous but will occur just when the charge should be ignited.

Any form of timer may have one extra terminal in addition to the number required for the number of cylinders. This terminal is to be used for grounding one side of the battery in place of allowing the battery to be grounded on the frame or other part of the car. This gives a path of low resistance from the battery to the timer, much lower than the resistance of the frame and bearings through which the battery current would otherwise pass.

The action of a timer and multiple unit coil system is as follows: The current starts from the positive side of the battery and passes through a wire leading to the switch. When the switch is placed in the battery position the current flows through the switch contacts and to a wire that leads to one of the primary winding terminals on each coil. This wire is called the common connection on the coil. There is another wire from the other primary coil terminal to one of the ter-

minals on the timer, a wire being run from each coil to one of the timer contacts. When the moving arm of the timer is in a position so that it makes contact with one of the segments the current flows through that coil and to the timer, through the segment or contact and into the arm. This arm is grounded through its driving shaft and in case the timer has the extra grounding terminal the arm also grounds through this terminal. The current thus flows to a ground connection, and, inasmuch as the other side of the battery is connected to the ground terminal on the timer or to the frame of the car the current returns to the battery.

It will be seen that as the timer arm turns, the current is allowed to flow first to one coil and then to another. The arm must be set so that a coil is caused to deliver high tension current (by receiving low tension current through the timer) when the spark is wanted in the cylinder to which that coil is connected by a high tension spark plug wire. The arm may be moved by loosening the timer sleeve from the driving shaft and turning it to the proper position. The timer may be moved a short distance around the shaft by a lever and rods running to the steering wheel or column or within reach of the driver. This gives the necessary spark advance and retard.

When the timer is combined with a distributor the current flows from the battery through the switch and coil and to the terminal on the timer that connects all the segments or contacts together. As the arm rotates the current passes to the ground every time the arm makes contact with any one of the segments so that the coil is caused to deliver a high tension current. This high tension current is not led directly to the

IGNITION

cylinders but returns from the coil to the center terminal on the distributor. This center terminal is connected to a rotating brush inside the distributor, this brush making contact with a segment in the distributor that delivers the spark current to the proper cylinder through the spark plug wire attached to one of the terminals on the outside of the distributor.

The timer and distributor are advanced and retarded together.

The roller in the timer and the bearing at the center should be oiled with light machine oil or vaseline once a month. The roller must be free to rotate on its pin and must be replaced if worn flat on one side.

The small spring that holds the moving contact against the segments must be strong enough to cause a good firm contact at all times. The arm held by this spring must move freely so that it can follow the inside surface of the timer cylinder.

This inside surface of the insulation and segments must be smooth and round at all points, having no high places or low places at the ends of the segments. If there are rough or high or low spots the timer must be placed in the lathe and turned out round.

The timer must not be loose and wobbly on its bearings, must not have play in the advance and retard parts and must be kept clean and free from dust and dirt inside the case.

VIBRATORS.

The platinum contact points of vibrators on coils must be clean and bright and free from pits, ash and roughness by dressing them with a fine file or by drawing a special cloth between them, this cloth being coated on both sides with emery or carborundum.

In dressing, care must be used that when the opera-

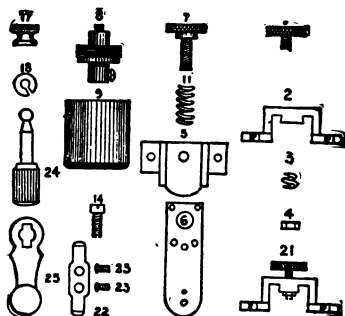

VIBRATOR AND COIL PARTS,

1, Locking screw; 2, Bridge holding the adjusting screw; 3, Adjusting screw locking spring; 4, Adjusting screw lock nut; 5, Holder for rear end of spring; 6, Vibrator spring and platinum contact; 7, Adjusting screws with platinum contact; 8, Coil wire terminal; 9, Terminal insulating cover; 11, Coil spring for vibrator; 14, Screw holding bridge to coil; 17, Coil terminal nut; 18, Terminal lock washer; 21, Adjusting screw in bridge; 22, Vibrator spring holder; 24, Switch plug; 25, Switch lever.

tion is finished the contacts meet each other true and square and over their whole surface, not at one edge or in the center.

All parts of a vibrator must be kept clean and free from grease, dust or oil.

The platinum contacts will wear or burn away in

time and may be renewed as directed under Contact Point Care.

To adjust a vibrator:

1st. See that the points are in proper condition as directed.

2d. Turn the adjusting screw up and then down, noticing which way brings the points away from each other.

3d. Turn the screw until the points are entirely separated and turn the other way until they just touch.

4th. Turn the engine over until the timer causes current to flow through the vibrator you are adjusting. Do not cause this current to flow by running any extra wires or in any other than the regular way because when the engine is running the current will have to take this path and the vibrator should be adjusted accordingly.

5th. Turn the switch off and remove the spark plug wire that receives current from the coil you are adjusting and hold this wire with its end about one-fourth inch from the metal of the cylinder.

6th. Turn on the switch and see if the spark jumps the space. If there is a continuous, even bright spark across the one-fourth inch gap the vibrator is properly adjusted.

7th. If the spark will not jump this space turn the adjusting screw so that the points are tighter together until the spark will jump. If this does not make it jump the points need renewing, they are not platinum or the coil is defective or the vibrator parts are sticking or the batteries are weak.

Screwing the points tighter together uses more battery current so they should be left as loose as will give a sufficient spark to run the engine properly.

WIRING.

Wires are made from stranded or braided copper. The copper is covered with a layer of rubber, cotton or silk to insulate the current and protect the wires from the atmosphere and moisture. The insulation may be composed of rubber alone or of rubber with either cotton or silk covering, the amount or thickness of the insulation being suited to the current carried. High amperage requires large copper and small insulation, high voltage requires only small wire but heavy insulation.

Duplex and multiple cables have insulating coverings that carry two or more copper conductors in the one cover but insulated from each other. This type of cable is used where only one line is wanted carrying both positive and negative sides of a circuit or several circuits, such as lamp wires, wires from the timer to the coils, etc.

High tension wire is understood to be suitable for carrying the spark current of 10,000 or more volts. This cable for use with magneto current is usually covered with rubber only and is from nine thirty-seconds to three-eighths of an inch outside diameter. Cable for battery current is usually covered with cotton or silk and is from three-eighths to one-half inch in outside diameter.

Low tension wire has a larger copper conductor than the high tension, but, with the insulation composed of rubber and cotton, the outside diameter is

only from seven thirty-seconds to nine thirty-seconds inches.

When wires are connected to terminals of electrical parts the end of a wire must be fitted into and soldered to a special brass or copper or hard rubber covered terminal that is designed to attach to the screw or terminal.

To make a joint between two wires, the ends must be scraped free of insulation for about one inch and then twisted around each other so that they cannot pull apart. This joint must then be filled with solder and covered with a layer of rubber tape and then with two or three layers of friction tape.

Wiring Troubles.

1. Wire disconnected. Look especially at the ground wires.
2. Spark plug wires on wrong. Find the correct firing order.
3. Loose ends on terminals. Should be tightened with pliers.
4. Cover worn off. New wire, or tape the old one.
5. Wires rubbing against metal. New wire, or tape old one and fasten.
6. Wire broken inside of cover. New wire.
7. Broken wire or terminals. New wire or terminals.
8. Wires wet or dirty. Must be kept clean and dry.

Alphabetical List of Contents

Black figures indicate section; light face figures, page in that section.

	SEC. PAGE
Accumulator, see Storage Battery.	
Acetylene, see Gas.	
Acid, battery	4—82
Adjustment—ball joint	1—11
bearing, annular	1—15
cup and cone.....	1—17
plain	1—18
roller	1—26
brake	1—28
carburetor	1—38
Breeze	1—43
Holly	1—45
Kingston	1—46
Rayfield	1—47
Schebler	1—51
Stromberg	1—56
Zenith	1—62
chain	1—72
clutch, band	1—78
cone	1—80
dry plate	1—83
multiple disc	1—84
ignition, see under name of part	
lubricator	1—122
planetary transmission	1—166
radius rod	1—133
steering gear	1—149
timing gears, see Valve Timing	
transmission gears	1—122
wrist pin	1—201
Advance and retard.....	5—4, 65
Air intake, auxiliary	1—37
primary	1—37
A. L. A. M. Spark plug.....	5—72
Alcohol	2—3

	SEC. PAGE
Alternating current	3-8; 4-22
Ammeter	3-15; 4-9
connecting	4-73
indicator	4-9
reading	4-28, 135
Amperage	3-13
of dry cells	5-18, 21, 22
of lamps	4-57
Ampere	3-13
hours	3-13; 4-29, 81
regulation, see Regulation	
turns	3-23
Annular ball bearings, see Bearings	
Anti-freeze mixtures	1-93; 2-3, 13
Armature	4-16
core	4-23, 43
magnet	3-19
magneto	4-34-43
shaft	4-43
tunnell	4-21
windings	4-21, 42; 5-6
Assembling, see under name of part	
Attraction, magnetic	3-18
Atwater-Kent ignition	5-52
Auxiliary air intake or valve	1-37-66
spark gap	5-67
springs	1-144
Axle	1-3
camber	1-3
front	1-3
full floating	1-5, 9
rear	1-5
semi-floating	1-5
three quarter floating	1-5
Babbitt bearings	1-17
Ball bearing, annular	1-13
cup and cone	1-16
lubrication	1-14, 17, 18, 26
Ball and socket joint	1-11
Bar, commutator	4-23, 26
magnet	3-18
Base, dynamo	4-39
lamp	4-58
magneto	5-42
Battery	3-6
charging, see Storage Battery	
connectors	5-20
dry, see Dry Cells	
Edison	3-8; 4-95

	SEC. PAGE
Battery	
ignition, see Ignition	
storage, see Storage Battery	
testing	3—14; 4—84, 92, 99
Bayonet lamp base	4—58
Bearing, annular ball	1—13
armature shaft	4—43
cam shaft	1—34
cup and cone	1—16
plain	1—17
roller	1—25
scraping	1—21
wrist pin	1—201
Benzol	2—5
Block chains	1—71
Body polish	2—18
Box, junction	4—12
Brake adjustment	1—28
electric	4—130
emergency	1—28
facing or lining	1—30
service	1—28
Breakage, see under name of part	
Breaker	5—3, 62
point care	5—5
timing, magneto	5—46
vibrating	5—81
Breeze carburetor	1—43
Bronze bearings	1—17
Brush, distributor	5—24
dynamo	4—16, 23, 45
holder	4—26, 46
insulation	4—26, 46
motor	4—16, 23, 45
pig tail	4—26
springs	4—27, 46
Bucking coil	4—34, 121
magnets	4—21
regulation	4—34, 121
Building up of dynamo	4—31
Bulbs, see Lamps	
Burner, gas	2—6
Cable, see Wires	
Calcium carbide	2—5
Cam shaft bearings	1—34
adjustment	1—35
Cams	1—33
Camber of wheels	1—3
Candelabra lamp base	4—59

	SEC. PAGE
Candlepower of lamps	4—54
Cantilever spring	1—144
Carbide, calcium	2—5
Carbon lamp bulbs	4—57
Carburetor	1—36
adjustment	1—38
assembling	1—63
design	1—36
fuel feed	1—114
heating	1—67
piping	1—120
troubles	1—41, 63, 64
Care, see under name of Part	
Cartridge fuse	4—64
Castor oil	2—7
Cells, dry see Dry Cells	
storage, see Storage Battery	
Centrifugal cut-out	* 4—102
Chain	1—71
adjustment	1—72
broken	1—73
lubrication	1—71
size	1—74
wear	1—73
Chalk	2—7
Change speed, see Transmission	
Charging, battery, see Storage battery	
indicator	4—109
Circuit	4—51
broken	4—51
short	4—72
tester	4—70
tracing	4—72
Clicking noises	1—130
Clincher tires and rims	1—152
Clutch	1—75
band	1—78
cone	1—79
dry plate	1—82
facing	1—30
location	1—75
multiple disc	1—84
overrunning	4—48
removal	1—75
Coil, battery	5—6
bucking, see Bucking coil	
induction	3—24
master vibrator	5—7
multiple unit	5—12
single unit	5—11

INDEX

v

	SEC. PAGE
Coil	
spark	5-6, 29
step up	3-24
transformer	3-24; 5-6
vibrator	5-81
wiring, magneto	5-52
Combined unit system	4-15
Commutator, battery, see Timer	
dynamo or motor	4-16, 23, 43
segments	4-23, 26
Compound field regulation	4-121
magnet	3-19
winding	4-34, 37
Compression	1-87, 135
stroke	1-87
Concentric float	1-38
Condenser	1-13
Conductor	2-5
Cone clutch	1-79
Connecting rod	1-90
bearing adjustment	1-18
eight cylinder types	1-104
Connections, battery	3-9
lamp	3-9
Connectors, battery	5-20
Constant armature speed	4-126
driving power	4-126
Construction, see under name of parts	
Contact breaker	5-3
point care	5-15
Contracting band clutch	1-78
Control, dynamo, see Regulation	
spark and throttle	1-139
Cooling system	1-92
troubles	1-93, 94
Core, armature	4-23, 43
field	4-47
Cork, ground	2-8
Coupling, Oldham	5-35
Cracked cylinder	1-99
Cracks, see under name of part	
Crank shaft	1-97
bearings	1-97
adjustment	1-18
Cup and cone ball bearings	1-16
Current, alternating	3-8; 4-22
direct	3-9
electricity	3-4
flow	3-5, 8, 13; 4-51
indicators	4-9

	SEC. PAGE
Current	
measurement	3—12, 14; 4—9
output of dynamo	4—27, 29, 112
path	4—51
regulation, see Regulation	
sources	3—5
Cut-out	4—8, 101
adjustment	4—10
centrifugal	4—102
electro magnetic	4—105
hand operated	4—101
indicators	4—109
mercury switch	4—104
opening and closing	4—10
Cycle	1—206
four	1—206
two	1—172
Cylinder	1—98
cracked	1—99
removal and replacement	1—98
scratched	1—99
Demountable rims	1—153
Denatured alcohol	2—5
Design, see under name of part	
Differential gears	1—101
piston engine	1—177
winding, see Bucking Coil	
Direct current	3—9
Direction of flow	3—8
Disc clutch	1—84
Distribution panel	4—13
Distributor	5—23, 47, 79
-timer	5—25, 79
firing order	5—24
wiring	5—45, 47
Double ignition	5—52, 27
point ignition	5—73, 75
row annular bearings	1—14
wire system	4—61
Dressing, body	2—18
top	2—20
Drive, dynamo or motor	4—47
magneto	5—35
Driving chains	1—71
Dry Cell	3—6; 4—17
amperage	4—18, 21, 22
connecting	4—20
construction	4—17; 3—6
restoring	4—19
voltage	4—18

	SEC. PAGE
Dry plate clutch	1—82
Dual ignition	5—27, 56
magneto wiring	5—53, 56
Duplex ignition	5—28
magneto wiring	5—54
wire	5—83
Dynamo	4—7, 16, 39
action	4—16
armature, see Armature	
assembling	4—40
brushes	4—23, 45
care	4—39, 41
commutator	4—23, 43
control, see Regulation	
drive	4—47
fields	4—16, 19, 30, 47
mounting	4—39
Dynamotor	4—14, 38
Ediswan lamp base	4—58
Edison battery	3—8; 4—95
Efficiency of lamps	4—56
of storage battery	4—82
Eight cylinder engines	1—103
firing orders	1—104
Electric, see name of Part or Thing	
Electricity, kinds of	3—3
Electrolyte, battery	4—77, 79, 82
Electro-magnet	3—21
polarity	3—21, 22
strength	3—23
series connected	4—105
shunt connected	4—105
Electro-magnetic cut-out	4—105
regulators	4—113
Engine, four cycle	1—205
two cycle	1—172
eight cylinder	1—103
Exhaust manifold	1—106
stroke	1—205
Expanding band clutch	1—78
Explosion stroke	1—205
Extra air intake	1—37, 66
long spark plug	5—72
Facing, brake and clutch	1—30
Feed, fuel	1—114
Fibre grease	2—13

	SEC. PAGE
Field	3-17; 4-16, 19, 30
core	4-47
current regulation, see Regulation	
magnets	4-19
permanent magnet	4-19
winding	4-19, 30, 47
bucking coil	4-34
characteristics	4-35
compound	4-34, 37
differential	4-34
series	4-31, 35
shunt	4-32, 37
Filament, lamp	4-55
Fire point of oil	2-17
Firing orders	1-104, 107
point	5-46; 1-205
Fitting, see under name of Part	
Flash point of oil	2-16
Flax	2-19
Float	1-37
chamber	1-37
concentric	1-38
level	1-40
lever	1-37
valve	1-37
Flow, current	3-5, 13
direction of	3-8
Fly wheel	1-109
Ford carburetor adjustment	1-45, 46
clutch	1-84
magneto	5-41
ignition	5-7, 12, 77, 81
transmission	1-166, 167
valve timing	1-181, 184
Four cycle engine	1-205
magneto	5-35
Four pole electric machines	4-22
Frame, straightening	1-111
Friction transmission	1-158, 169
Front axle	1-3
Fuel, alcohol	2-3
benzol	2-5
feed	1-114
gasoline	2-8
kerosene	2-13
Full elliptic spring	1-142
floating axle	1-5, 9
Fuse	4-12, 62, 64, 73
box	4-65

INDEX

ix

	SEC. PAGE
Gap, auxiliary spark	5-67
safety spark	5-67
spark plug point	5-69
Gas burners	2-6
generators	2-5
lamps	2-6
pipes	2-6
tanks	2-3
Gasoline	2-8
feed	1-114
for cleaning	2-10
joint packing	2-10
Gear shift	1-157
electric	4-133
Gears, differential	1-101
rear axle	1-3
starter	4-48, 128
timing	1-118
transmission, see Transmission	
Generator, electric, see Dynamo	
gas	2-5
-igniter	4-15
Glycerine	2-10
Governor, cut-out	4-102
dynamo clutch	4-126
Grain alcohol	2-5
Graphite	2-10
Grating noise	1-129
Gravity fuel feed	1-114
Grease	2-11
cup	2-12
fibre	2-13
graphite	2-13
mica	2-14
non-fluid	2-13
transmission	2-12
Gredag	2-11
Grid, battery	4-77
Grinding noises	1-129
valves	1-182
Grounding wires	4-61, 66, 72
Grounds, testing for	4-72
Half elliptic spring	1-142
inch spark plug	5-71
Hand operated cut-out	4-101
Heating, carburetor	1-67
plugs	1-70

	SEC. PAGE
High tension	3-27
distributor, see Distributor	
magneto, see Magneto	
wiring	5-83
winding	3-27
Hissing noises	1-129
Holder, brush	4-26, 46
Holley carburetor	1-45
Horsepower of starting motor	3-14; 4-128
Horseshoe magnet	3-18
Hydrometer, battery testing	4-84
gasoline testing	2-9
Igniter, low tension	5-30
Ignition	5-1
Atwater Kent	5-62
battery, distributor	5-23
master vibrator	5-7
multiple unit coil	5-12
requirements	4-81
single coil	5-11
timer	5-77
timer-distributor	5-79
vibrator	5-81
double	5-27, 52
dual	5-27, 53, 56
duplex	5-28, 54
low tension	5-29
magneto, see Magneto	
make and break, see Make and Break	
master vibrator	5-7
set spark	5-27, 66
single	5-27, 52
single spark	5-62
transformer coil	5-28
two point	5-66, 75
variable spark	5-28
wires	5-83
Indicator, current	4-9
cut-out	4-109
Induction	2-4; 3-24
coil	3-24
Inductor magneto	5-38
Inlet manifold	1-120
stroke	1-204
Insulation	3-5
broken	4-72
brush	4-26, 46
spark plug	5-71

	SEC. PAGE
Inter brush regulation	4-126
pole regulation	4-126
Interrupted field currents	4-127
Interrupter, see Breaker and Vibrator	
Iron magnet	3-19
Joint, ball and socket	1-11
gasoline pipe	2-10
universal, see Universal	1-179
wire	4-41; 5-84
Junction box	4-12
Keepers, magnet	3-19
Kerosene	2-13
cleaning	2-14
cooling	2-14
decarbonizing	2-14
fuel	2-13
loosening parts	2-14
Kingston carburetor	1-46
Knife switches	4-69
Knight engine valve timing.....	1-181, 189
Knocking	1-128
K-W master vibrator	5-7
Lag in coils	5-65
Lamps	4-53
amperage	4-57
bases	4-58
candlepower	4-53
carbon	4-57
connections	4-57, 60
efficiency	4-56
filament	4-55
fuses	4-12, 62, 64, 73
gas	2-6
life	4-56
pilot	4-110
size	4-54
tantalum	4-57
tester	4-70
tungsten	4-57
voltage	4-56, 58
wiring	4-12, 51, 60, 66
Lapping cylinder	1-99
shaft bearings	1-24
Lava spark plugs	5-71
Law of Ohm	3-15
Laying up a battery	4-90

	SEC. PAGE
Leak, compression	1—87
inlet piping	1—120
oil or grease	1—15, 23, 27
radiator	2—19
Life of lamps	4—56
Lighting	4—3, 51
and starting	4—3
batteries, see Storage batteries	
switches	4—67
wires	4—12, 51, 66
Lines of force	3—17
Lining brakes and clutches	1—30
Liquid, battery	4—79, 82
Litharge and glycerine	2—10
Live axles	1—7
Location of clutch	1—75
spark plug	5—72
Long spark plugs	5—72
Loose cams	1—33
wires	4—71
Low tension	3—27
ignition	5—27, 29
magneto	5—31, 56
Ford	5—41
wiring	5—56
make and break, see Make and Break	
Lubricating oil	2—15
Lubrication	1—122
ball bearing	1—14, 17
chain	1—72
clutch, band	1—78
cone	1—79
dry plate	1—82
multiple disc	1—84, 86
daily, weekly, etc.	1—124
friction transmission	1—170
plain bearing	1—18
planetary transmission	1—166
roller bearing	1—26
sliding gear	1—158
steering gear	1—149
universal joint	1—179
Machine oil	2—14
Magnet	3—17
armature	3—19; 4—105
compound	3—19
electro—see Electro magnet	
field, see Field	
forms of	3—18

	SEC. PAGE
Magnet	
keepers	3—19
permanent	3—19; 4—106
placing on magneto	5—38
poles	3—18, 20, 21; 4—106
Magnetic attraction	3—18
cut-out	4—105
electricity	3—3, 17
field, see Field	
force, lines of	3—17, 20
pole finding	3—20
poles	3—18
Magnetism	3—3, 17
Magnetizing	3—19
Magneto	5—34
action	5—34
armature	5—34, 43
breaker timing	5—46
coil wiring	5—51
direction of turning	5—45
distributor, see Distributor	
drive	5—35
Ford	5—41
four cylinder	5—38
high tension	5—34
inductor	5—38
low tension	5—31, 56
lubrication	5—42
make and break, see Make and Break	
mounting	5—42
one cylinder	5—35
safety gap	5—67
six cylinder	5—38
speed of rotation	5—35
terminal finding	5—48, 56
three cylinder	5—35
timing, armature	5—43
breaker	5—45, 46
distributor	5—45, 47
troubles	5—42, 43
two cylinder	5—35
cycle	5—38
spark	5—73, 75
wiring, dual	5—56
distributor	5—45, 47
duplex	5—54
high tension	5—52, 54
low tension	5—31, 56
transformer coil	5—54, 56

	SEC. PAGE
Make and Break	5—29
advance and retard.....	5—30, 31
care and use.....	5—31
change to high.....	5—33
igniters	5—30
timing	5—32
troubles	5—32
Manifold, exhaust	1—106
heating	1—67
inlet	1—120
Master vibrator	5—7
Measurement of current.....	3—12, 14; 4—9
Mercury switch cut-out	4—104
Metal polish	2—18
Metric spark plug	5—72
Mica, flake	2—14
spark plug	5—71
Miniature lamp bases.....	4—59
Mixing chamber	1—37
Mixture, see Carburetor Adjustment and Troubles	
Motor-generator	4—14, 38
Motor, starting (see Dynamo also).....	4—13
care and handling	4—39
compound wound	4—34, 37
drive	4—47, 128
clutch	4—48
power	3—14; 4—128
requirements	4—128
series wound	4—31, 35
shunt wound	4—32, 37
Mounting, dynamo or motor.....	4—39
magneto	5—42
Multiple connection	3—11
of cells	3—11
of lamps	3—11; 4—60
disc clutch	1—84
series connection	3—12; 5—22
unit coil	5—12
wires	5—83
Neatsfoot oil	2—15
Negative	3—9
pole	3—18
terminal finding	3—9
wire finding	3—9
Noisy operation	1—128
North pole	3—18
Nozzle, carburetor	1—36
Ohm	3—14
Ohm's law	3—15

INDEX

xv

	SEC. PAGE
Oil, castor	2-7
kerosene	2-13
lubricating	2-15
machine	2-14
neatsfoot	2-15
non-fluid	2-13
soap	2-19
Oildag	2-10
Oiling, see Lubrication	
Oldham coupling	5-35
One cylinder magneto	5-35
unit system	4-14
wire system	4-61
Order of firing	1-104, 107
Output of dynamo, see Dynamo	
regulation, see Regulation	
Overcharge, battery	4-90
Overrunning clutch	4-48
Paint, tire	2-20
Panel, distribution	4-13
Parallel connection	3-11
cells	3-11
lamps	3-11
Path of current	4-51
Permanent magnet	3-19; 4-106
Pet cock spark plug	5-73
Pig tails, brush	4-26
Pilot lamp	4-110
Pins, wrist	1-201
Pipes, gas	2-6
Piston pins	1-201
ring fitting	1-131
removal and replacement	1-133
Plain bearings	1-17
adjustment	1-18
Planetary transmission	1-157, 164
adjustment	1-166
removal	1-167
Plate clutch	1-82
Platinum point care	5-15
Play in steering gear	1-149
Plug, electric heating	1-70
spark, see Spark Plug	
Points, breaker or vibrator	5-15
Polarity	3-9
magnetic	3-17, 20
wires	3-9; 4-73
Pole, magnetic	3-18, 20
pieces	4-20

	SEC. PAGE
Polish, body	2—18
metal	2—18
Poppet valve timing	1—181, 184
Popping noises	1—130
Porcelain spark plugs	5—71
Positive	3—9
pole	3—18
wire	3—9; 4—73
Pounding noises	1—128
Power, electrical	3—14; 4—128
loss of	1—135
stroke	1—205
Pressure, electrical	3—12
fuel feed	1—114
tire	1—154
Prest-O-Lite	2—3
Primary	3—27
air intake	1—37
coil	3—24
current	3—27
winding	3—27
wiring	5—51, 56
Priming spark plug	5—73
Progressive transmission	1—157
Protection of wires	4—66
Pump, water	1—93, 94
Push button switches	4—67
rod adjustment	1—188
Quantity of electricity	3—13
Quarter elliptic spring	1—142
Quick detachable tires and rims.....	1—152
Radiant electricity	3—4
Radiator	1—92
compound	2—19
Radius rods	1—138
Rate of flow	3—13
Rattling noises	1—130
Rayfield carburetor	1—47
Reading the ammeter	4—135
Rear axle	1—5
bent	1—10
leaks	1—8
loose dogs	1—9
lubrication	1—7
noisy	1—7
Reduction gear, starter	4—128
Regulation	4—7, 28, 112
armature position	4—121

	SEC. PAGE
Regulation	
bucking coil	4—121
common systems	4—127
compound field winding	4—37, 121
constant speed	4—126
constant power	4—126
current output	4—112
cut-out	4—110
differential field	4—121
dynamo output	4—28, 113
electro-magnetic	4—113
extra brush	4—126
extra pole	4—126
large field	4—125
pole piece movable	4—121
reversed field	4—127
rotating field	4—126
saturated field	4—125
shunt field	4—35, 115
voltage	4—7, 27, 112
Removal, see under name of Part	
Repairs, see under name of Part	
Replacing, see under name of Part	
Relay, cut-out	4—8, 101
Residual magnetism	4—31
Resistance, electrical	3—5, 12, 14
Retard of spark	5—4, 65
Reverse current cut-out	4—8, 101
Reversed field regulation	4—127
wiring connections	4—73
Rims, clincher	1—152
demountable	1—153
quick detachable	1—152
straight side	1—153
Ring, piston	1—131
Rod, connecting	1—90
radius	1—138
torsion	1—156
Roller bearing adjustment	1—26
lubrication	1—26
troubles	1—27
chains	1—71
Rotary switches	4—67
valve timing	1—182, 194
Rotating field regulation	4—126
Safety spark gap	5—67
Saturated field regulation	4—125
Schebler carburetor	1—51
Scraping bearings	1—21
noises	1—129

	SEC. PAGE
Screw lamp bases	4—59
Searchlight gas	2—3
Secondary, see High tension	
Segments, commutator	4—23, 26
Selective transmission	1—157
Self-aligning bearings	1—14
Semi-elliptic springs	1—142
floating axles	1—5
Separate coil ignition	5—6
unit systems	4—15
Series connection	3—11
cells	3—11
lamps	3—11; 4—60
electro magnet	4—105
-multiple	3—12
of cells	3—12
winding	4—31, 35
Set spark ignition	5—27, 66
Seven-eighths elliptic springs	1—142
Shaft, armature	4—43
bearing truing	1—24
cam	1—34
crank	1—97
Shims, bearing	1—19
Short circuit finding	4—72
tester	4—70
Shunt	3—11
electro-magnet	4—105
field regulation, see Regulation	
winding	4—32, 37
Silent chains	1—71
Single ignition	5—27, 52, 66
row annular bearing	1—14
spark ignition	5—62
unit coil	5—11
unit system	4—14, 15
wire system	4—61
Six cylinder magneto	5—38
pole electric machines	4—22
Size of lamp bulbs	4—54
Sleeve valve timing	1—181, 189
Slapping noises	1—129
Sliding gear transmission	1—157
Snap switch	4—69
Soap, oil	2—19
Soapstone	2—7
Solenoid	3—23; 4—119
Sources of current	3—5
South pole	3—18

	SEC. PAGE
Spark advance and retard	5-4, 65
and throttle control	1-139
coil	5-6, 29
gap, auxiliary	5-67
safety	5-67
plug	5-69
A. L. A. M.	5-72
cleaning	5-69
gap	5-69
gaskets	5-70
half inch	5-71
insulation	5-71
lengths	5-72
location	5-72
metric	5-72
priming cup	5-73
sizes	5-71
threads	5-71
troubles	5-74
two point	5-73
wiring	5-45, 47
set	5-27
timing, see Breaker and Timer	
Sparker, single	5-62
Specific gravity, battery	4-84, 89
gasoline	2-9
Speed of electric current	3-13
Spitting noises	1-130
Split bearing, see Plain Bearings	
Spring	1-142
auxiliary	1-144
bolt	1-144
bracket	1-144
brush	4-27, 46
clips	1-144
eyes	1-144
seats	1-144
shackles	1-144
size	1-145
type	1-142
Squeaking noises	1-130
Starting	4-4, 13
battery	4-81
motor, see Motor and Dynamo	
switches	4-67
Static electricity	3-3
Steering gear	1-5, 147
joints	1-149
looseness	1-11, 149
lubrication	1-149
wheel adjustment	1-149

	SEC. PAGE
Step up coil	2-24; 5-6
Storage battery	3-6; 4-7, 77
acid	4-79, 82
capacity	4-29, 81
care	4-87
charging	3-7, 29; 4-7, 64, 88, 109, 115
charge indicator	4-109
construction	3-7; 4-77
Edison	3-8; 4-95
efficiency	4-82
electrolyte	4-79, 82, 87
hydrometer	4-84
laying up	4-90
liquid	4-79, 82
size	4-27
sulphated	4-90
testing	4-85, 91
types	4-81
voltage	4-82, 96
Straight side tires and rims	1-153
Strength of electro magnet	3-23
Stroke, compression	1-204
exhaust	1-205
explosion	1-205
inlet	1-204
power	1-205
suction	1-204
Stromberg carburetor	1-56
Suction stroke	1-204
Sulphated storage battery	4-90
Sulphuric acid	4-82
Switches	4-11, 66
lighting	4-67
starting	4-66
Talc, tire	2-7
Tanks, acetylene gas	2-3
Tantalum lamp bulbs	4-57
Tension, high and low	3-27
Terminal finding	3-9
magneto	5-48
Tester, circuit	4-70; 5-53
Testing, ammeter	3-15; 4-9
dry cells	5-18
storage battery	3-15; 4-82, 92
Thread, spark plug	5-71
Three cylinder magneto	5-35
port, two cycle engine	1-176
quarter elliptic spring	1-142
floating axle	1-5

Three cylinder magneto	
unit system	4-15
wire system	4-62
Threshing noises	1-129
Throttle and spark control	1-139
carburetor	1-37
stops	1-63
Timer	5-77
action	5-78
and coil ignition	5-78
-distributor	5-29, 79
Timing, distributor	5-45, 47
firing orders	1-104, 107
gears	1-118
Knight engine	1-181, 189
magneto armature	5-43
breaker	5-45, 46
distributor	5-45, 47
make and break magneto	5-32
poppet valves	1-181, 184
rotary valves	1-182, 194
sleeve valves	1-181, 189
spark, see Breaker and Timer	
timer	5-78
valves	1-184, 189, 194
Tire, clincher	1-152
quick detachable	1-152
paint	2-20
powder	2-7, 14
pressure	1-154
straight side	1-152
talc	2-7
vulcanizing	1-195
Top dressing	2-20
Torsion rod	1-156
Tracing circuits	4-72
Transformer coil	3-24; 5-6
ignition, see Ignition	
wiring	5-53, 56
Transmission	1-157
electric gear shift	4-133
friction	1-158, 169
leaky	1-15, 27
lubrication	1-158, 166, 170
planetary	1-157, 164
sliding gear	1-157, 158
Trembler, see Vibrator	
Triple wire system	4-62

	SEC. PAGE
Troubles, axle	1—38
battery	4—87
bearing, cup and cone	1—17
plain	1—24
roller	1—27
cams	1—34
carburetor	1—41, 64
chains	1—73
clutch, band	1—78
cone	1—80
dry plate	1—83
multiple disc	1—85
connecting rod	1—90
cooling system	1—93, 94
crank shaft	1—97
cylinder	1—99
engine	1—128, 135
exhaust manifold	1—106
finding with ammeter	4—28, 135
tester	4—70
frame	1—111
friction transmission	1—171
ignition, see under name of Part	
inlet manifold	1—121
magneto	5—43
noisy operation	1—128
oiling	1—126
planetary transmission	1—168
power, loss of	1—135
sliding gear transmissions	1—163
spark plug	5—74
spring	1—145
timing gears	1—118
tire	1—154
two cycle	1—175
valve	1—135, 182
wheels	1—199
wiring	5—84
wrst pin	1—202
True high tension magneto	5—52, 53
Truing shaft bearings	1—24
Tungsten lamp bulbs	4—57
Tunnel, armature	4—21
Two cycle engine	1—172
magneto	5—38
cylinder magneto	5—35
diameter piston engine	1—177
pole electric machines	4—22
port, two cycle engine	1—172

Two cycle engine	
spark ignition	5-73, 75
plug	5-73
unit system	4-15
wire system	4-61
Types, see under name of Part	
Unisparker	5-52
Units, lighting and starting	4-14
Universal joint	1-179
lubrication	1-179
Uses, see under name of Part	
U shaped magnets	3-18
Vacuum fuel feed	1-115
Valve	1-181
grinding	1-182
removal	1-182
rod adjustment	1-188
timing	1-184, 189, 194
Knight engine	1-181, 189
poppet type	1-181, 184
rotary type	1-182, 194
sleeve type	1-181, 189
Variable spark ignition	5-28
Vaseline	2-20
Verdigris removal	4-87
Vibrator	5-81
adjustment	5-82
master	5-7
point care	5-15
Voltage	3-12
dry cells	5-18, 21
lamp	4-56
regulation	4-27
storage battery	4-82, 96
Voltaic electricity	3-4
Voltammeter	3-15
Voltmeter	3-14; 4-9
connecting	4-73
Vulcanizing	1-195
Water, battery	4-85
system, see Cooling	
Watts	3-14; 4-128
Wheels	1-199
fly	1-109
lining up	1-149
removing	1-199
Wheezing noises	1-129

	SEC. PAGE
Winding, armature	4—21, 42
bucking coil, see Bucking Coil	
electro magnet	4—105
field, see Field Winding	
primary	3—27
secondary	3—27
Wire wheels	1—199
Wires	4—66; 5—83
bared	4—72
broken or loose	4—71
duplex	5—83
high tension	5—83
ignition, see Ignition	
lighting	4—53
low tension	5—83
multiple	5—83
polarity	4—73
protection	4—66
Wiring	4—51; 5—83
care	5—84
connections	3—9; 4—73
distributor	5—47
double ignition	5—52
dry cell	4—20
dual ignition	5—53, 56
fuses	4—12, 62, 64, 73
high tension magneto	5—83
ignition, see Ignition	
lighting	4—12, 51, 60, 61, 66
low tension magneto	5—56
magneto	5—31, 52
master vibrator	5—7
multiple	3—11
series	3—12
one wire system	4—61
separate coil magneto	5—6
single wire system	4—61
series connection	3—11
spark plug	5—45, 47
tester	4—70
three wire system	4—62
troubles	5—84
two wire system	4—61
Wood alcohol	2—3
Wrist pins	1—201
Zenith carburetor	1—62

89090514951



b89090514951a

STQ
M31

KURT F. WENDT LIBRARY
COLLEGE OF ENGINEERING
UNIVERSITY OF WISCONSIN
MADISON, WISCONSIN

89090514951



B89090514951A