



Safety Recall: 2003–07 Accord Power Steering Feed Hose Leak

(Supersedes 13-012, dated January 26, 2013, to revise the information marked by the black bars)

REVISION SUMMARY

Under REPAIR PROCEDURE, a step was changed.

BACKGROUND

Prolonged high under-hood temperature and high power steering fluid temperatures may cause the power steering hose to deteriorate prematurely and may cause the hose to crack and leak power steering fluid. Power steering fluid leaking onto a hot catalytic converter will generate smoke and could lead to an under-hood fire.

NOTE: Vehicles that were repaired under Service Bulletin 12-066, *Safety Recall: 2003–07 Accord Power Steering Feed Hose Leak*, must still be repaired under this bulletin to make sure the updated power steering hose is installed. If you need a copy of 12-066, please send a feedback requesting it.

CUSTOMER NOTIFICATION

Owners of affected vehicles will be sent a notification of this campaign in February 2013.

Do an **iN VIN status inquiry** to make sure the vehicle is shown as eligible.

Some vehicles affected by this campaign may be in your used vehicle inventory. These vehicles must be repaired before they are sold.

Should a dealership sell an unrepaired vehicle that subsequently causes an injury or damage because of the recalled item, the dealership will be solely responsible to the damaged party, and will be required to defend and indemnify American Honda for any resulting claims. To see if a vehicle in inventory is affected by this campaign, do a VIN status inquiry before selling it.

CORRECTIVE ACTION

Install an updated power steering feed hose kit.

PARTS INFORMATION

P/S Feed Hose Kit: P/N 06530-SDB-315

Included parts:

- Exhaust Pipe Gasket (x2)
- Feed Line Holder (x1)
- Feed Line Holder Insulator (x1)
- Flange Bolt (10 x 40 mm) (x1)
- Flange Bolt (10 x 68 mm) (x1)
- Flange Bolt (10 x 70 mm) (x2)
- Nut (10 mm) (x9)
- O-ring (x1)
- Power Steering Hose (x1)
- Rear Gasket (x1)

NOTE:

- Use only the countermeasured part for this repair because the precountermeasured hoses have not been updated and could deteriorate over time.
- You may receive P/N 06530-SDB-306, instead of 06530-SDB-315; the parts are the same.

REQUIRED MATERIALS

Honda Genuine Power Steering Fluid:
P/N 08206-9002

(Each vehicle may need up to three 12 oz. bottles.)

WARRANTY CLAIM INFORMATION

Operation Number: 5121G8

Flat Rate Time: 1.2 hours

Failed Part: P/N 53713-SDB-A01

Defect Code: 5NP00

Symptom Code: S6000

Skill Level: Repair Technician



REPAIR PROCEDURE

1. Drain the P/S fluid.

- Raise the reservoir, then disconnect the return hose to drain the reservoir. Take care not to spill the fluid. Rinse off any spilled fluid immediately with water.
- Connect a properly sized hose to the disconnected return hose, and put the hose in a container large enough to hold the fluid.
- Start the engine, let it idle, then turn the steering wheel from lock to lock several times. When the fluid stops running out of the hose, turn off the engine. Appropriately discard the fluid.
- Reinstall the return hose on the reservoir.

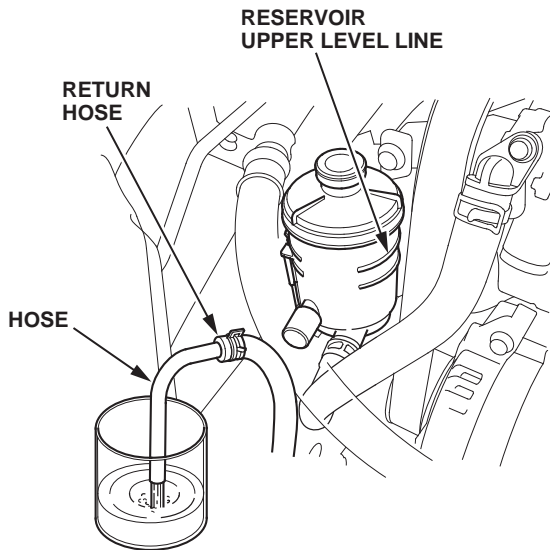

2. Remove the P/S pump outlet hose from the P/S pump, then plug the outlet hose and the P/S pump. Remove the P/S feed hose from the clamp.

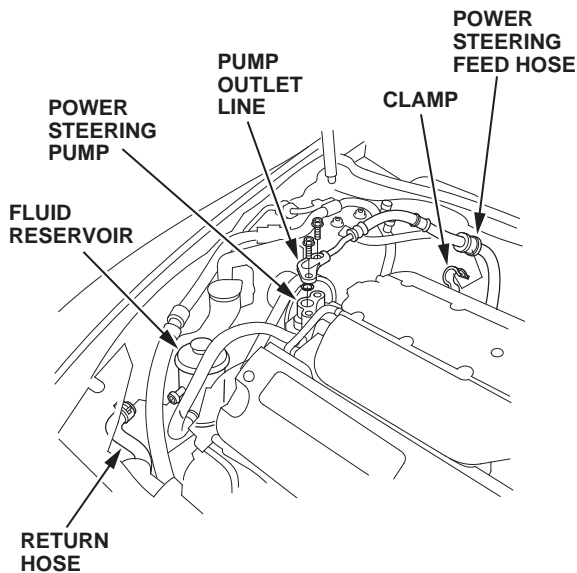

3. Disconnect the P/S pressure switch connector.

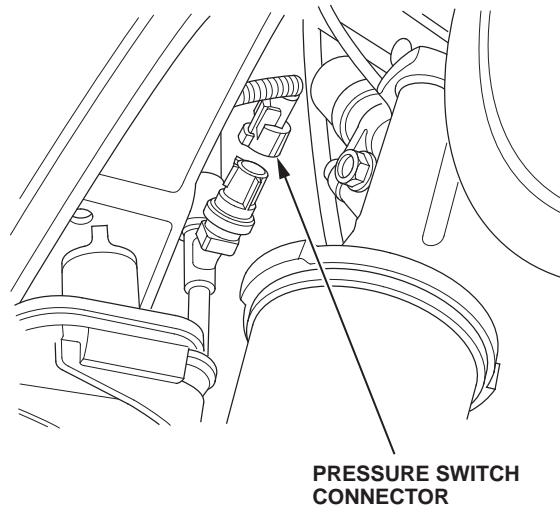

4. Remove the bolts securing the feed line holders.

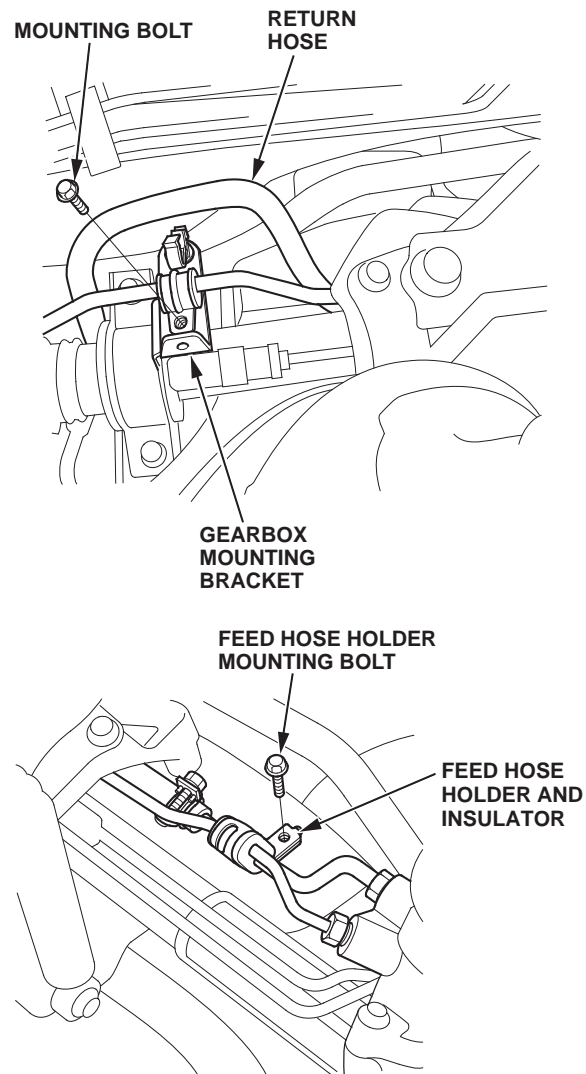

5. Raise the vehicle on a lift.

6. Remove exhaust pipe A:
 - Remove the rubber exhaust hanger from the subframe.
 - Remove exhaust pipe A (nine self-locking nuts). Leave the three way catalytic converter (TWC) on the vehicle.
 - Support exhaust pipe B with a wire.

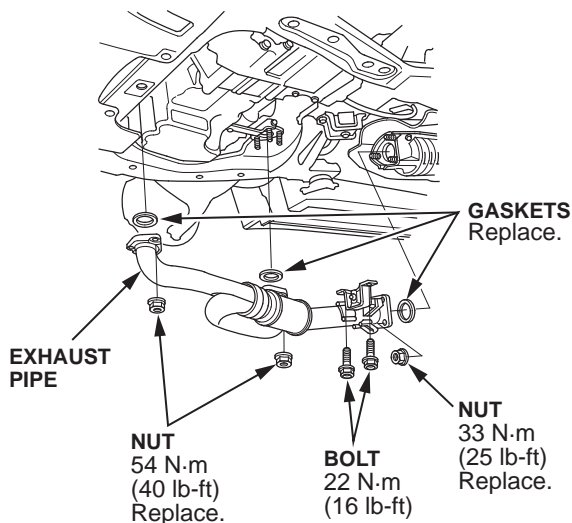

7. Remove the P/S heat baffle plate.

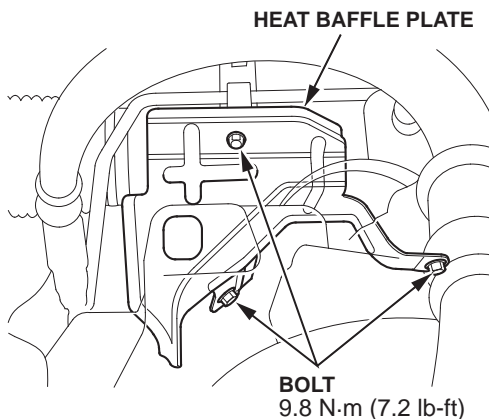

8. Disconnect the P/S feed line from the steering gearbox by loosening its flare nut.

NOTE: To prevent fluid from dripping, place several shop towels under the feed line connection, and wrap a towel around the exposed joint end.

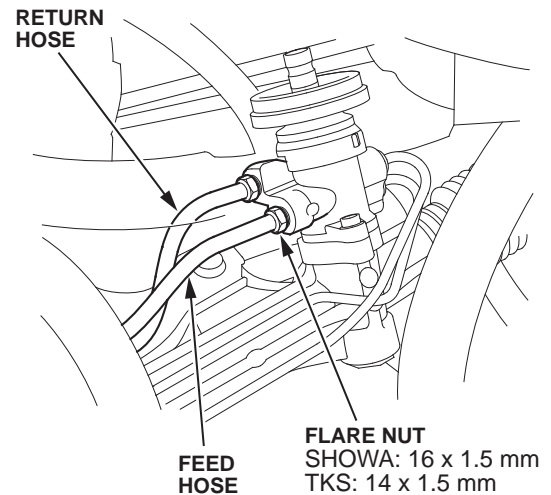

9. Remove the four rear engine mount bracket bolts from the subframe.

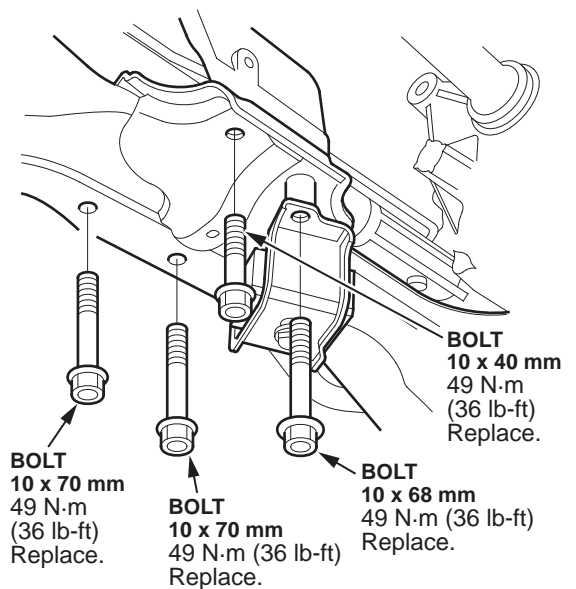

10. Using a transmission jack, carefully lift the engine until the rear engine bracket lifts off the rear part of the subframe.

NOTE: To minimize the stress damage on the other engine/transmission mounts, do not lift the assembly more than an inch.

11. Push up on the rear engine mount bracket and remove the P/S feed hose. Wipe up any P/S fluid that may have spilled.
12. Lower the transmission jack, then lower the vehicle.

13. Remove the P/S feed hose from the top of the engine. Make sure you don't damage the high pressure switch because it will be reused.

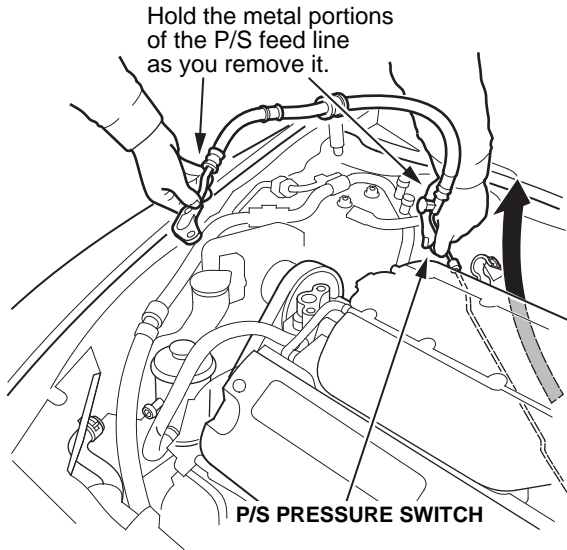

14. Transfer the P/S pressure switch from the old feed hose and install it on the new one with a new O-ring. Torque the switch to **12 N·m (8.7 lb-ft)**.
- > Power steering hose
 - > O-ring
15. Install the replacement P/S hose and install the new feed line holder and insulator.
- > Feed line holder
 - > Feed line holder insulator
16. Raise the vehicle.
17. Reconnect the P/S feed hose, and torque the flare nut to **28 N·m (21 lb-ft)**.
18. Install, and torque the four new rear engine mount bracket bolts to **49 N·m (36 lb-ft)**.
- > Flange bolt (10x40)
 - > Flange bolt (10x68)
 - > Flange bolt (10x70) (x2)
19. Reinstall the P/S heat baffle plate, and torque the bolts to **9.8 N·m (7.2 lb-ft)**.
20. Reinstall the feed hose holder at the gearbox mounting bracket, and torque the bolt to **9.8 N·m (7.2 lb-ft)**.
21. Reinstall exhaust pipe A using new gaskets and new self-locking nuts. Use the torque specs in step 6.
- > Rear gasket
 - > Exhaust pipe gasket (x2)
 - > Nut (10 mm) (x9)
22. Lower the vehicle.

23. Connect the P/S pressure switch connector.
24. Install the P/S hose to the pump and torque the bolts to **11 N·m (8 lb-ft)**, then install the hose in the clamp.
25. Fill the P/S reservoir to the upper level line.
- NOTE:
- Use Honda Genuine Power Steering Fluid.
 - The system capacity is **1.1 L (37.2 oz.)**.
 - The reservoir capacity is **0.32 L (10.8 oz.)**.
26. Start the engine, run it at a fast idle, and turn the steering wheel from lock to lock several times. This will bleed any air from the P/S system.
27. Recheck the fluid level, and add more if needed. Do not fill the reservoir above the upper level line.
- NOTE:
- Make sure you remove all shop towels used during the procedure.
 - Rinse off any spilled P/S fluid with water.

Example of Customer Letter

February 2013

Safety Recall: 2003–07 Accord Power Steering Feed Hose Leak - NHTSA Recall 12V-222

Dear Honda Accord Owner:

This notice is sent to you in accordance with the requirements of the National Traffic and Motor Vehicle Safety Act. You were notified about this issue last year. We are contacting you now to schedule an appointment to repair your vehicle, free of charge.

What is the reason for this notice?

Honda has decided that a defect which relates to motor vehicle safety exists in certain 2003-2007 model year Accord V6 vehicles. Prolonged high under-hood temperatures and high power steering fluid temperatures may cause the power steering hose to deteriorate prematurely and may cause the hose to crack and leak power steering fluid. Fluid leaking onto a hot catalytic converter will generate smoke, a burning smell and possibly lead to an under-hood fire.

What should you do?

Call any authorized Honda dealer and make an appointment to have your vehicle repaired at no cost to you. The dealer will replace the power steering hose even if the hose was previously replaced. The complete replacement process may take approximately 72 minutes; however, your vehicle will need to be at the dealer for a longer period of time. We recommend that you plan to leave your vehicle for half a day to allow the dealer flexibility in scheduling.

Who to contact if you experience problems?

If you are not satisfied with the service you receive from your Honda dealer, you may write to:

American Honda Motor Co., Inc.
Honda Automobile Customer Service
Mail Stop 500-2N-7A
1919 Torrance Blvd.
Torrance, CA 90501-2746

If you believe that American Honda or the dealer has failed or is unable to remedy the defect in your vehicle, without charge, within a reasonable period of time (60 days from the date you first contact the dealer for a repair appointment), you may submit a complaint to:

Administrator
National Highway Traffic Safety Administration
1200 New Jersey Ave., SE
Washington, DC 20590

Or call the toll-free Safety Hotline at 1-888-327-4236 (TTY 1-800-424-9153), or go to <http://www.safercar.gov>.

What to do if you feel this notice is in error

Registration records indicate that you are the current owner or lessee of a 2003-2007 Honda Accord V6 involved in this campaign. If this is not the case, or the name/address information is not correct, please complete and sign the Information Change Card and return it in the enclosed postage-paid envelope. We will then update our records.

What if you already had your vehicle repaired for this issue?

If you previously paid to have the power steering hose replaced, you may be eligible for reimbursement. Refer to the attached Instructions for Reimbursement for eligibility requirements and the reimbursement procedure.

Lessor Information

Federal law requires that any vehicle lessor receiving this recall notice must forward a copy of this notice to the lessee within 10 days.

If you have questions

If you have any questions about this notice or any concerns or questions about your vehicle, please call Honda Automobile Customer Service at 800-999-1009, and select option 4. U.S. customers can also locate a dealer online at Honda.com. Customers in U.S. territories, please contact your local dealer/distributor.

We apologize for any inconvenience this campaign may cause you.

Sincerely,

American Honda Motor Co., Inc.
Honda Automobile Division