



Kawasaki Motors Corp., U.S.A.

July 31, 2012

Mr. Daniel Smith
Associate Administrator for Enforcement
National Highway Traffic Safety Administration
1200 New Jersey Avenue, SE
Washington, D.C. 20590

Re: Recall No. 12V-343 Supplemental Information

Dear Mr. Smith:

Kawasaki Motors Corp., U.S.A. ("KMC") hereby provides additional information needed to fully comply with the reporting requirements of 49CFR 573.5 (c). This correspondence supplements the previous Defect Report dated July 18, 2012.

- 9) A representative copy of all notices, bulletins and other communications that relate directly to the defect or noncompliance: Copies of the first issued service bulletin and customer letter are attached. The service bulletin was mailed to dealers on July 27, 2012 and the customer letter began mailing on July 27, 2012 .

Please contact the undersigned if there are any questions regarding information in this submission, or if additional information is required.

Sincerely,
KAWASAKI MOTORS CORP., U.S.A.

Russel Brenan
Senior Advisor, Government Relations and Public Affairs

Enclosure

P . O . B o x 2 5 2 5 2
Santa Ana, California
9 2 7 9 9 - 5 2 5 2

9 4 9 / 7 7 0 - 0 4 0 0
F a x 9 4 9 / 4 6 0 - 5 6 0 0
w w w . k a w a s a k i . c o m

9950 Jeronimo Road
Irvine, California
9 2 6 1 8 - 2 0 8 4

REPLACES: This Recall campaign replaces Recall MC 09-01 issued January 6, 2009, for eligible ZG1400A8F/L, B8F/L, A9F/L, B9F/L models only.

MODEL: 2008 ~ 2012 Concours™14 & 14 ABS (ZG1400A8F/L, B8F/L, A9F/L, B9F/L, CAF/L, CBF/L, CCF/L, DAF/L)

TITLE: REAR MASTER CYLINDER ROD END REPLACEMENT

RECALL

THIS BULLETIN IS OF THE HIGHEST PRIORITY AND MUST BE ACTED UPON IMMEDIATELY TO ENSURE CUSTOMER SAFETY.

Eligibility

Eligible Units

Model	Vehicle Identification Number Eligibility
ZG1400A8F/L, A9F/L, ZG1400B8F/L, B9F/L, ZG1400CAF/L, CBF/L, CCF/L, ZG1400DAF/L	Check VIP in K-Dealer

Verify eligibility using VIP in K-Dealer before starting the repair.

Please check VIP (Vehicle Information Portal) in K-Dealer for other possible repair campaigns for eligible units.

Subject

On eligible units, small stones and other road debris can become trapped between the brake pedal and the brake pedal cover. This can cause the rear (and ZG1400C model front) brakes to drag and overheat, potentially leading to brake damage, lock-up, or failure, creating the potential for a crash resulting in injury or death.

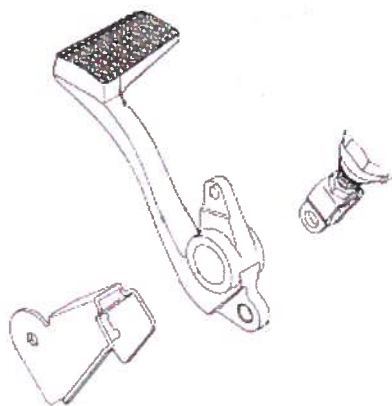

Kawasaki Action

Initiate Campaign:

Kawasaki has initiated a Recall campaign to repair all eligible units. The repair consists of removing the brake guard (if installed) and replacing the rear master cylinder rod end.

Notify Registered Owners:

Kawasaki is sending a Recall letter to all registered owners of eligible units. A copy of the letter is printed on page 5 of this bulletin.

Dealer Action

Repair Eligible Units:

Repair all eligible units including sold units in the field and unsold units in your dealership inventory prior to delivery to the retail purchaser. It is the obligation of authorized Kawasaki retail Dealers to repair eligible units in Dealer's possession prior to retail sale. Failure to comply with this obligation to repair all units eligible for Recall or FDM campaigns by the Dealer constitutes a breach of the Dealer Sales and Service Agreement. Refer to Service Policies bulletin SP 08-01. Refer to the Repair Procedure section of this bulletin for details.

IMPORTANT NOTE:

- o *It's the law! Under the U.S. National Highway Traffic Safety Administration (NHTSA), Federal Law 49 U.S.C. Section 30120(i) requires dealers to perform Recall repairs before delivering any vehicle affected by the Recall to a purchaser.*

File behind the "MC" tab in your Kawasaki "Service and Warranty" binder

©2012, Kawasaki Motors Corp., U.S.A.

Kawasaki
Let the good times roll.™

Document Completed Repairs:

Federal law requires manufacturers to maintain accurate follow-up records on repairs performed on eligible units. Dealers MUST submit a Warranty Claim for each repair. Refer to the Warranty Information section of this bulletin for details.

NOTE:

- o If you fail to submit a Warranty Claim for a new unit that is subsequently sold and registered, the new owner will receive the Recall letter requesting the return of the vehicle to you for repair.

Submit Product Registration:

Submit the product registration to Kawasaki via K-Dealer immediately after retail sale of any eligible unit. Be sure to supply the correct customer name and mailing address. Kawasaki uses the product registration information for customer notification. Also, if you know that the customer has moved, please submit a Customer Update via K-Dealer.

Repair Procedure

Refer to the appropriate sections of Service Manual for information and procedures related to parts removal and installation.

Service Manual

Model	Service Manual
ZG1400A8F/A9F/B8F/B9F	99924-1379-02
ZG1400CAF/CBF/CCF/DAF	99924-1431-03

- Remove and retain the master cylinder mounting bolts.
- Remove and retain the right footpeg bracket bolts.

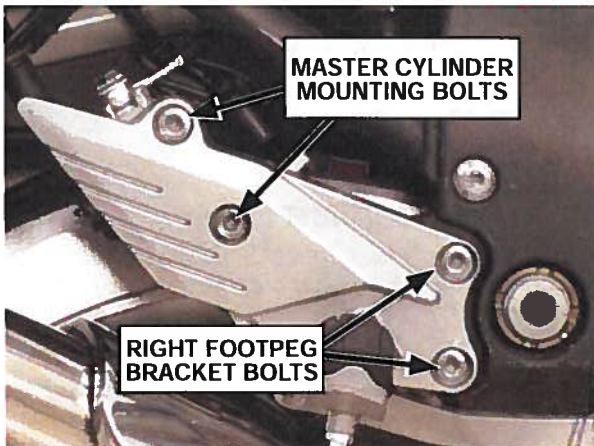

- Remove and discard the brake pedal bolt and washer.
- Remove and discard the brake pedal guard.

NOTE:

- o Vehicles that did not have recall MC09-01 completed will not have a brake pedal guard installed.



- Temporarily install the rear brake pedal assembly on the footpeg bracket.
- Loosen the master cylinder rod end lock nut.

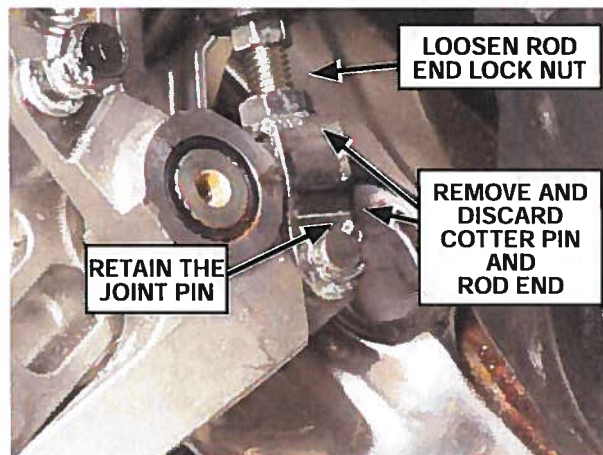

- Remove and discard the cotter pin.
- Remove and retain the joint pin.
- Remove and discard the rod end.

- Install the new rod end from the repair kit
- Install the joint pin.
- Install the new cotter pin from the repair kit.
- Install the new brake pedal washer and bolt from the repair kit and tighten the bolt to 8.8N·m(0.90 kgf-m, 78in-lb).

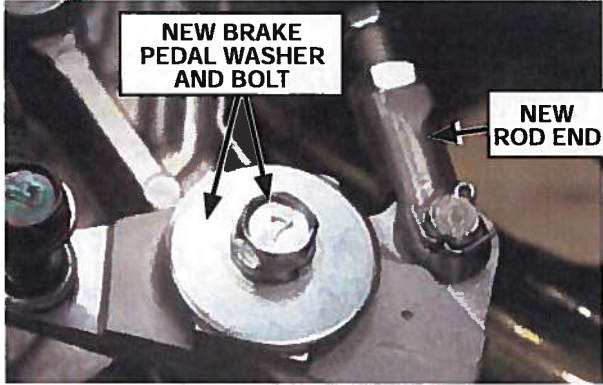

- Install the right footpeg bracket and tighten the bolts to 25N·m(2.5 kgf-m, 18ft-lb).

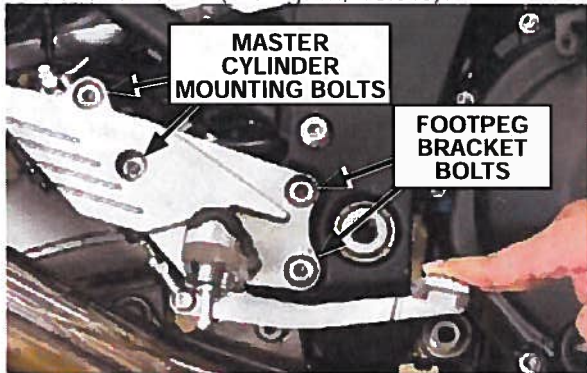

- Depress the brake pedal to align the master cylinder bolt holes, install the bolts, and tighten the bolts to 25N·m(2.5 kgf-m, 18ft-lb).

Adjust Brake Pedal Height:

ZG1400A8F/B8F Brake Pedal Height Adjustment



- Adjust the rear master cylinder push rod to a length of 7mm (.27in) measured between the two nuts and tighten temporarily.

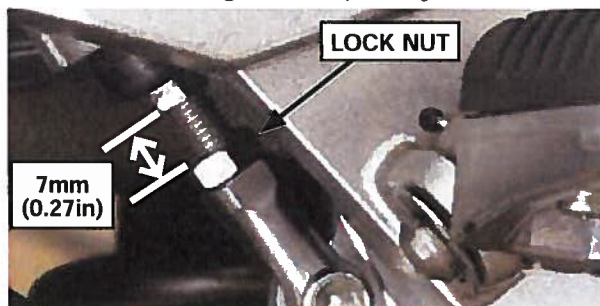

- Check for clearance between the rod end and the top of the brake pedal.

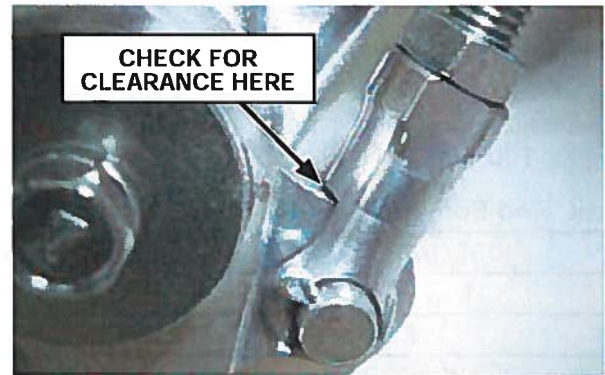

- Adjust (lengthen) the rear master cylinder push rod to achieve the least amount of clearance possible without binding the rod end, brake pedal, or master cylinder push rod. Do not exceed 9mm measured between the two nuts.
- Tighten the lock nut to 17.2N·m(1.8 kgf-m, 13ft-lb).

ZG1400A9F/B9F/CAF/CBF/CCF/DAF Brake Pedal Height Adjustment



- Adjust the rear master cylinder push rod to a length of 9mm (0.35 in) measured between the two nuts and tighten the lock nut to 17.2N·m (1.8 kgf-m, 13ft-lb).

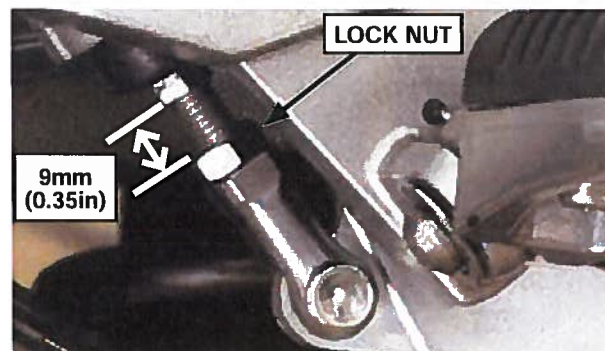

Parts Information

A rod end kit must be installed on all eligible units.

Order parts to complete the Recall through K-Dealer as outlined in Service Bulletin SP12-02 issued July 24, 2012.

Kit, Rod End, P/N 99999-0389

KIT CONTENTS	QTY
Rod End	1
Bolt	1
Washer	1
Cotter Pin	1

NOTE:

- o Use VIP in K-Dealer to identify affected units in your dealership inventory to order repair kits for unsold units

Warranty Information

This is a safety Recall campaign. Repair is authorized regardless of ownership or warranty status.

Repairs **MUST BE PERFORMED IMMEDIATELY ON ALL ELIGIBLE UNITS** in the field and during initial assembly and preparation.

See the Warranty Policies and Procedures Manual (claim type 3 information) for detailed instructions when submitting the Warranty Claim.

Warranty Information

Job Code	22394
Flat Rate Time	0.3 hr.
Failure Date	Same as Repair Date
Claim Type	3
Problem Part Number	99999-0389
Description	Kit, Rod End
Qty	1

Repair Verification

Installation of the replacement rod end will serve as repair verification.

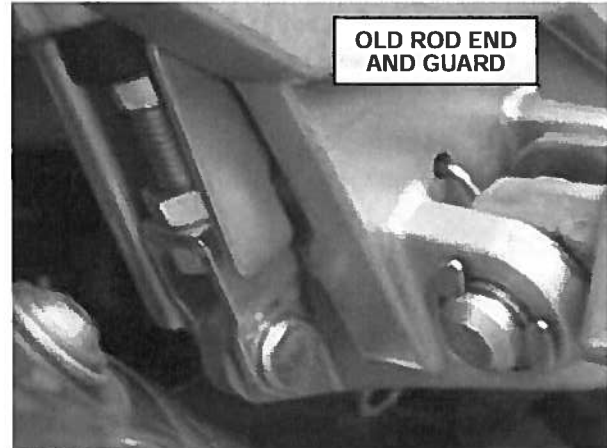

NOTE:

- o Repair verification is an essential part of the repair procedure. Along with the physical repair verification mark, check VIP (Vehicle Information Portal) in K-Dealer for other possible repair campaigns for eligible units.

**2008 ~ 2012 CONCOURS™14 & 14 ABS
REAR MASTER CYLINDER ROD END REPLACEMENT
WARNING AND RECALL NOTICE**

Dear Kawasaki Motorcycle Owner:

This notice has been sent to you in accordance with requirements of the National Traffic and Motor Vehicle Safety Act.

The reason for this notice:

Kawasaki Motors Corp., U.S.A. has decided that a defect which relates to motor vehicle safety exists in 2008 ~ 2012 Concours14 & 14 ABS (ZG1400A8F/L, A9F/L, B8F/L, B9F/L, CAF/L, CBF/L, CCF/L, DAFL) models. On eligible units, small stones and other road debris can become trapped between the brake pedal and the brake pedal cover. This can cause the rear (and ZG1400C model front) brakes to drag and overheat, potentially leading to brake damage, lock-up, or failure, creating the potential for a crash resulting in injury or death. Our records indicate that you have purchased one of these units. This recall campaign supersedes recall MC09-01 that was issued on January 6, 2009, for all eligible ZG1400A8F/L, B8F/L, A9F/L, B9F/L models.

What Kawasaki and your dealer will do:

Your Kawasaki dealer will correct this problem for you at no charge. The correction will consist of removing the brake guard (if installed) and replacing the rear master cylinder rod end. The actual repair will take up to 30 minutes but may take longer due to scheduling at the dealership and the time needed to obtain required parts.

What you must to do to ensure your safety:

Please call your authorized Kawasaki motorcycle dealer to schedule an appointment and take this letter with you at the time of your appointment.

If you need help:

If you have questions or concerns that your dealer is not able to resolve, please contact Kawasaki's Consumer Services Department at (866) 802-9381 (toll-free) between 8:00 a.m. and 5:00 p.m. PT Monday through Friday. Please have your Vehicle Identification Number ready when calling.

If your dealer fails or is unable to remedy this defect without charge within a reasonable amount of time (60 days after your first attempt to obtain remedy), you may submit a written complaint to the Administrator, National Highway Traffic Safety Administration, 1200 New Jersey Ave. S.E., Washington, D.C. 20590, or call the toll-free Vehicle Safety Hotline at 1(888) 327-4236 (TTY: 1-800-424-9153); or go to <http://www.safercar.gov>.

If you received this notice in error:

Our records indicate you are the current owner of the 2008 ~ 2012 Concours14 & 14 ABS described in this letter. If you no longer have the vehicle described in this letter, please help us to update our records at www.kawasaki.com by clicking on the "OWNER INFO" link or by calling Kawasaki toll free at (866) 802-9381. Federal regulation requires that any vehicle lessor receiving this recall notice must forward a copy of this notice to the lessee within ten days.

Reimbursement:

If you have experienced the failure described above prior to receiving this letter and have paid to have it corrected, you may be eligible for full or partial reimbursement for your documented cost of repair(s). To apply for reimbursement, please send copies of current owner and VIN information along with copies of repair orders and payment confirmation to the following address:

Kawasaki Motors Corp., U.S.A.
ATTN: Consumer Services Department
P.O. Box 25252
Santa Ana, California 92799-5252

Please note the following conditions for reimbursement:

- Only repairs specifically related to this recall are eligible for reimbursement. Other expenses such as towing, rental, and accommodations will not be refunded.
- Claims may be excluded if proper documentation is not included. Current owner and VIN information along with copies of repair orders and payment confirmation must be provided.

We are sorry for any inconvenience this may cause, but we have taken this action in the interest of your safety and your continued satisfaction with your Kawasaki motorcycle.

Sincerely,

Kawasaki Motors Corp., U.S.A.

