

(No Model.)

W. J. LAPWORTH.
ADJUSTABLE BOXING FOR VEHICLE WHEELS.

No. 549,646.

Patented Nov. 12, 1895.

Fig. 3.

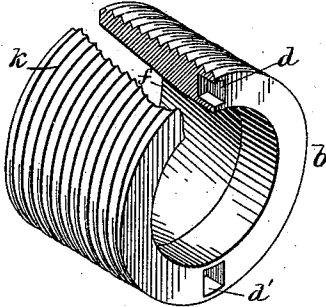

Fig. 4.

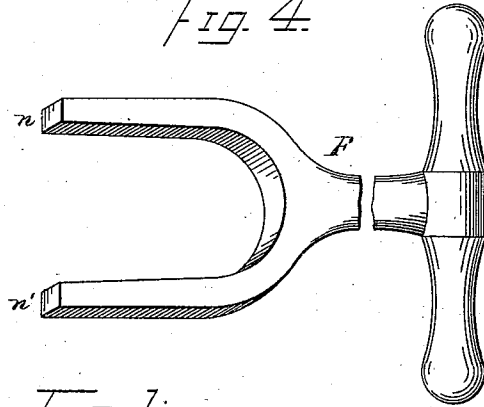

Fig. 1.

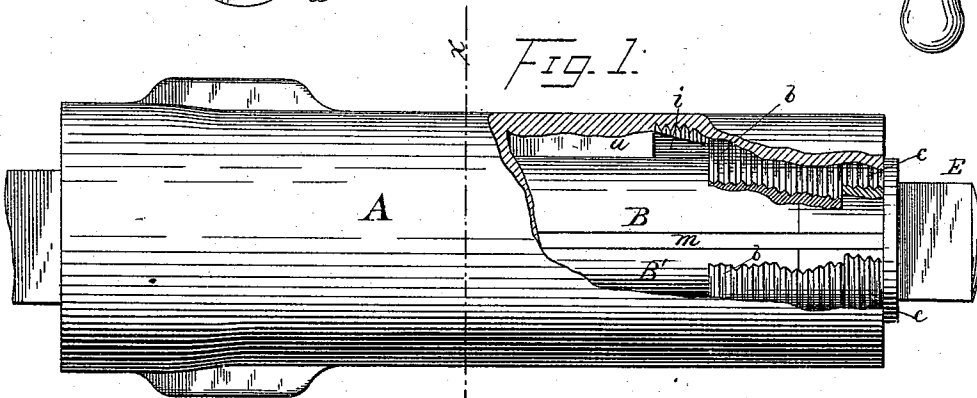

Fig. 2.

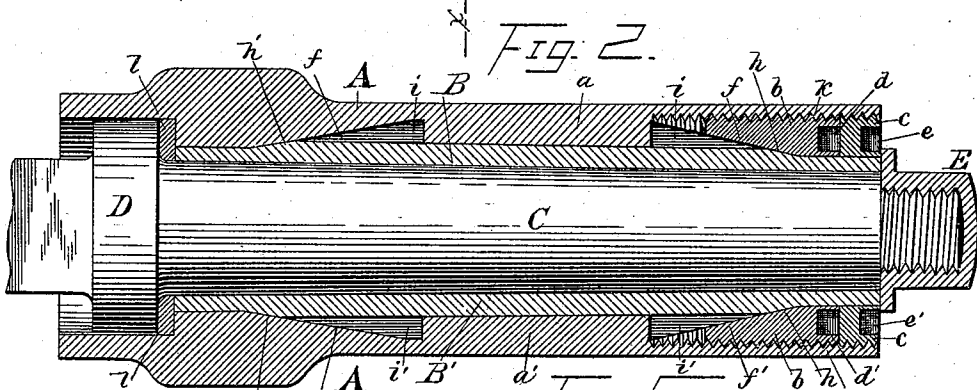
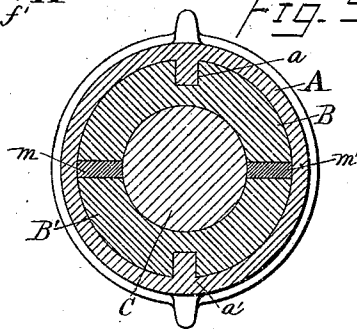

Fig. 5.



Witnesses:

M. H. Barringer.
A. C. Miller.

Inventor:

William J. Lapworth.

UNITED STATES PATENT OFFICE.

WILLIAM J. LAPWORTH, OF BEATRICE, NEBRASKA.

ADJUSTABLE BOXING FOR VEHICLE-WHEELS.

SPECIFICATION forming part of Letters Patent No. 549,646, dated November 12, 1895.

Application filed July 6, 1895. Serial No. 555,138. (No model.)

To all whom it may concern:

Be it known that I, WILLIAM J. LAPWORTH, a citizen of the United States, residing at Beatrice, in the county of Gage and State of Nebraska, have invented a new and useful Adjustable Boxing for a Vehicle-Wheel, of which the following is a specification.

My invention relates to the improvement over the old non-adjustable box; and the objects of my improvements are, first, to provide an adjustable boxing that will at all times be as firm as a solid box; second, one that will keep the wheel firm and true and have a much longer life than the solid box; third, one that can be adjusted by any person. I attain these objects by methods shown in the accompanying drawings, in which—

Figure 1 is a side elevation of the solid box with the upper right-hand corner broken away, so as to show the outside of box B B'. *m* is the metallic distance pieces or liners; *b*, wedge-nut for setting up the boxing; *c*, lock-nut to secure wedge-nut *b*; *i*, key-seat in boxing B. *a* is a key on box A to prevent boxing B B' from revolving. E is a nut on axle.

Fig. 2 is a longitudinal section of Fig. 1. A A is the solid box; B B', the adjustable boxing; *a a'*, keys; *i i*, key-seats; *f f'*, angle of wedge on boxing B B'; *h*, angle on wedge-nut *b*; *k*, threads; *d d'*, wrench-slots; *c*, lock-nut; *e e'*, wrench-slots. C is the axle; D, collar; *l*, leather washer; E, nut on end of axle.

Fig. 3 is a perspective view of wedge-nut *b*, broken away to show angle of wedge; *d d'*, wrench-slots; *k*, threads.

Fig. 4 is the wrench for adjusting nuts *b* and *c*.

Fig. 5 is a transverse section of Fig. 1 on line *x x*. *a a'* are the fixed keys; A, solid box; B B', adjustable boxing; *m m'*, metallic liners; C, axle.

To adjust boxing, take out lock-nut *c*, slack back wedge-nut *b*, reduce liners *m m'* to proper thickness, set up wedge-nut *b*, and lock with nut *c*, which will leave the boxing solid and firm, as when new.

What I claim as my invention, and desire to secure by Letters Patent, is—

In a boxing for a vehicle wheel, the combination, with the box A provided with a conical portion at one end, a screw-threaded chamber at the other end, and a cylindrical middle portion provided with keys; of two half bearings B B' for the axle, provided with conical ends and a cylindrical middle portion having slots engaging with the said keys, removable liners *m* interposed between the said half bearings, and a nut screwed into the said chamber and provided with a conical portion encircling one end of the said half bearings, and operating when screwed up to tighten the said half bearings upon the said liners, thereby forming a substantially solid cylindrical bearing for the axle, substantially as set forth.

WILLIAM J. LAPWORTH.

Witnesses:

J. S. RUTHERFORD,
M. H. WATTS.