

(No Model.)

T. LO CASTO.
AXLE BOX.

No. 549,926.

Patented Nov. 19, 1895.

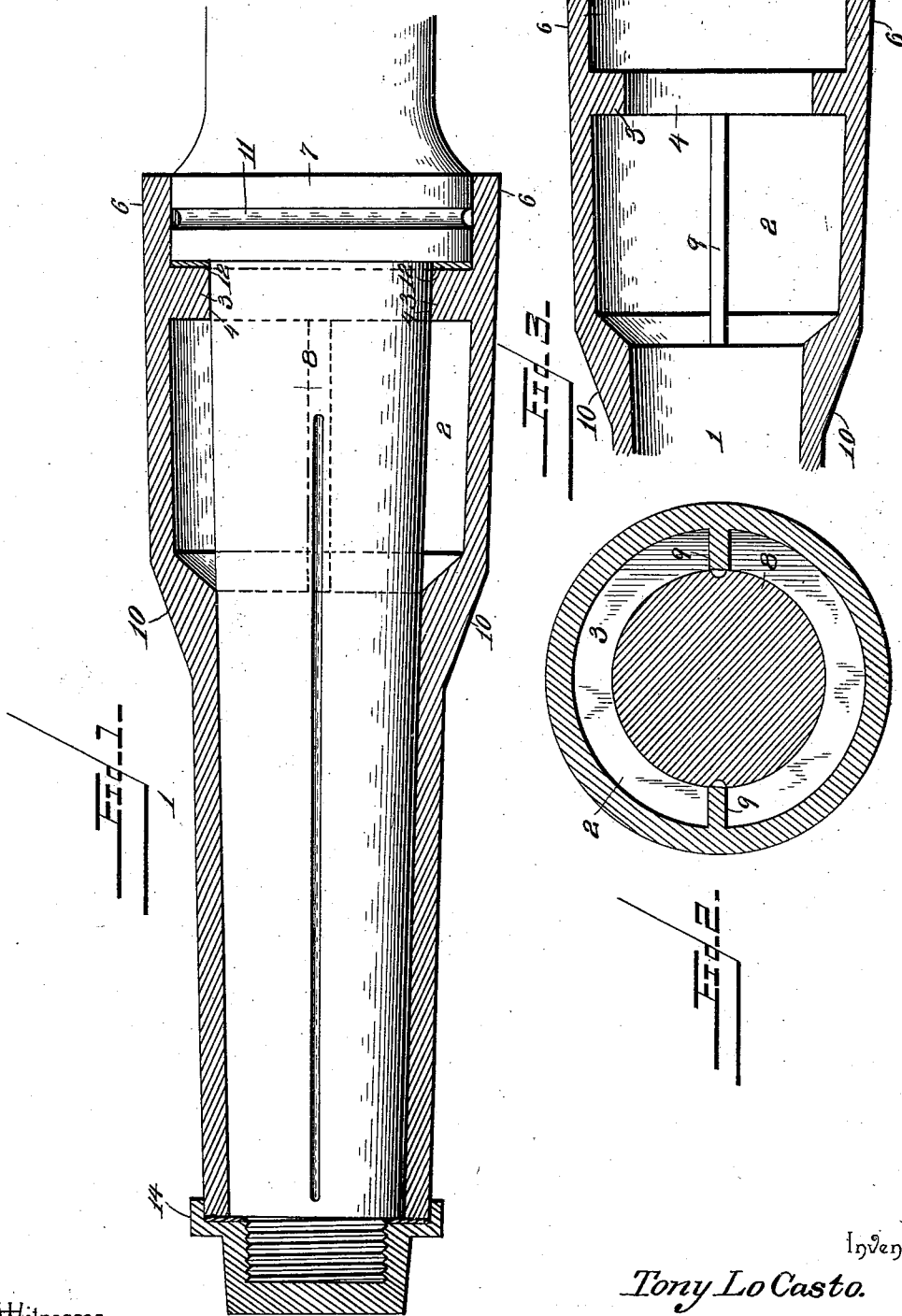

Inventor

Tony Lo Casto.

Witnesses

Thos W Riley
[Signature]

By his Attorneys.

[Signature]

UNITED STATES PATENT OFFICE.

TONY LO CASTO, OF MARSHALL, TEXAS.

AXLE-BOX.

SPECIFICATION forming part of Letters Patent No. 549,926, dated November 19, 1895.

Application filed March 14, 1895. Serial No. 541,766. (No model.)

To all whom it may concern:

Be it known that I, TONY LO CASTO, a citizen of the United States, residing at Marshall, in the county of Harrison and State of Texas, have invented a new and useful Axle-Box, of which the following is a specification.

My invention relates to a wheel-axle box; and the object in view is to provide a simple, inexpensive, and durable box adapted to contain a supply of lubricating material and constructed to feed the same continuously to the axle-spindle to prevent overheating, and, furthermore, to provide means for preventing ingress of dust.

Further objects and advantages of the invention will appear in the following description, and the novel features thereof will be particularly pointed out in the appended claims.

In the drawings, Figure 1 is a longitudinal section of an axle-box constructed in accordance with my invention. Fig. 2 is a transverse section through the lubricating-chamber. Fig. 3 is a detail longitudinal section with the spindle omitted.

Similar numerals of reference indicate corresponding parts in all the figures of the drawings.

1 designates the tubular body portion of the box, and 2 an enlarged portion communicating with said tubular portion and forming a lubricating-chamber, which is closed at the inner end by an abrupt wall 3, having an opening 4, which corresponds in diameter with the bore of the body portion of the box. The enlarged portion of the box is extended beyond said wall to form a dust-guard or flange 6, within which fits the collar 7 of the axle-spindle 8, said collar bearing against the inner surface of the wall 3. Extending from the outer surface of the wall to the outer end of the lubricating-chamber is a web 9, the edge of which is approximately flush with the surface of the bore of the box, said web serving to strengthen the enlarged portion of the box and also as a conveyer for the lubricating material to feed the same to the surface of the axle-spindle. One or more webs 9 may be employed, two being shown in the drawings. The box is also provided with an exterior ear or wing 10, whereby it may be

secured firmly in the hub of a wheel. The collar of the axle-spindle is provided with a circumferential groove 11 to serve as a dust-receptacle or stop, and a washer 12 is interposed between said collar and the inner surface of the wall 3. A similar washer is arranged between the outer end of the box and the cap-nut 13, which is provided with a flange 14 to overlap the outer extremity of the box, and thereby exclude dust at that point. The spindle is provided with a longitudinal oil-conducting groove of the usual construction.

Various changes in the form, proportion, and the minor details of construction may be resorted to without departing from the spirit or sacrificing any of the advantages of this invention.

Having described my invention, I claim—

1. An axle-box provided with an enlarged portion forming a lubricating chamber in communication with its bore and closed at its inner end by a wall beyond which the enlarged portion of the box extends to form a dust-guard or flange, and a longitudinally disposed web connecting the wall with the shoulder between the enlarged and body-portions of the box, and serving to strengthen said enlarged portion and convey lubricating material to the surface of an axle-spindle, substantially as specified.

2. The combination with an axle-spindle having a collar provided with a circumferential groove, of a box having a bore to receive said spindle, an enlarged portion forming a lubricating chamber and terminated at its inner end by a wall having an opening in registration with the bore of the body-portion of the axle-box, a dust-guard or flange to receive the collar of the axle, and a longitudinally disposed web arranged in the lubricating chamber and projecting approximately to the surface of the spindle, substantially as specified.

In testimony that I claim the foregoing as my own I have hereto affixed my signature in the presence of two witnesses.

TONY LO CASTO.

Witnesses:

HENRY R. STEPHENS,
HENRY YAKOL.