

(No Model.)

J. L. COOK.  
WHEEL AND AXLE.

No. 556,808.

Patented Mar. 24, 1896.

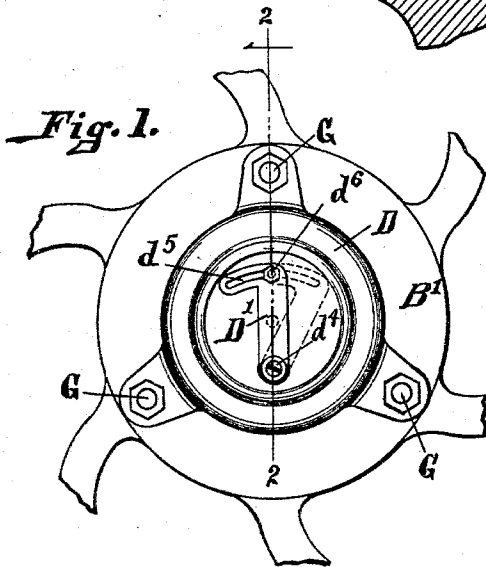
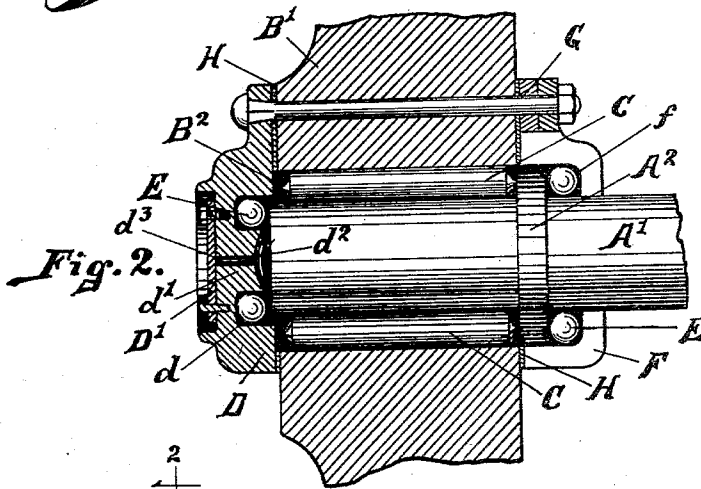
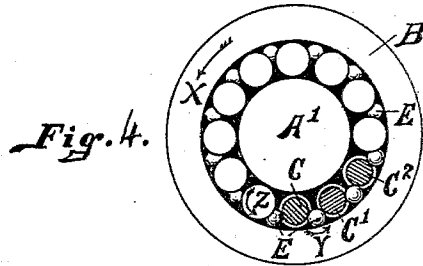
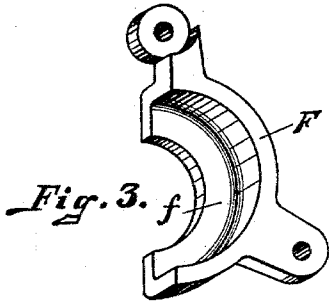

Witnesses,

Will Q. Olden  
Frank Henney.

Inventor,

James L. Cook  
By N. Dubois's Atty.

# UNITED STATES PATENT OFFICE.

JAMES L. COOK, OF SPRINGFIELD, ILLINOIS.

## WHEEL AND AXLE.

SPECIFICATION forming part of Letters Patent No. 556,808, dated March 24, 1896.

Application filed March 26, 1895. Serial No. 543,209. (No model.)

*To all whom it may concern:*

Be it known that I, JAMES L. COOK, a citizen of the United States, residing at Springfield, in the county of Sangamon and State of Illinois, have invented certain new and useful Improvements in Wheels and Axles for Vehicles; and I do hereby declare the following to be a full, clear, and exact description of the invention, such as will enable others skilled in the art to which it appertains to make and use the same.

My invention is especially applicable to mine-cars, but it may obviously be applied to any vehicle having a fixed axle on which the wheels turn.

The purposes of my invention are to provide a wheel having a box so constructed and arranged as to accommodate antifriction-rollers surrounding the axle, said rollers being in contact with the spindle on which the wheel turns along the whole length of said spindle, and also having channels adapted to accommodate balls arranged in such manner that as the wheel turns the balls will receive any end-thrust due to longitudinal movement of the wheel on the axle; to provide a cap for the wheel made in two separable parts, and provided with a channel adapted to accommodate balls; to provide an oil cup or cavity adapted to accommodate oil or other suitable lubricant; to provide a cover of novel and improved construction adapted to exclude dirt or grit from the oil-cavity and at the same time conveniently arranged for supplying oil to the oil-cavity, and to provide simple and effective means for connecting the caps with the wheels in such manner as to permit the adjustment of the caps relative to the ends of the rollers.

With these ends in view my invention consists of certain novel features of construction and combinations of parts shown in the annexed drawings, to which reference is hereby made, and hereinafter particularly described and specifically claimed.

In the drawings I have illustrated my improvement as applied to a mine-car. I have shown the improvement in its preferable form as applied to a wide-gage car.

In the drawings, Figure 1 is a partial side elevation of my improved wheel and axle. Fig. 2 is a vertical transverse section on the

line 2 of Fig. 1. Fig. 3 is an enlarged inside perspective view of one-half of one of the inside caps. Fig. 4 is a diagram showing a common form of the arrangement of balls interposed between rollers and running in grooves in the rollers. This view is intended to illustrate by comparison the practical advantage of my arrangement of the balls independently of the rollers.

Similar letters of reference indicate like parts in all of the views.

The mine-car may be of any usual and well-known form. The axle A', which is of rolled steel, is secured to the car in any suitable manner. In the drawings I have illustrated only one wheel-box and one end of the axle. Both wheel-boxes and both ends of the axle being identically alike, there is no occasion to illustrate more than one. The axle A' is rolled true to the required diameter, so that no finishing or tool-work is required on the axle. This is of obvious practical advantage, inasmuch as it is well known that a considerable part of the cost of construction of wheels and axles for mine-cars consists in the wages of labor employed in turning and fitting the spindle of the axle. The collars A<sup>2</sup> are shrunk on or otherwise suitably secured to the axle.

The body of the wheel B may be of any usual or well-known form; but I prefer to use a wheel in which the hub B' is integral with the spokes of the wheel. In the hub B' is a central bore B<sup>2</sup> of such diameter as to accommodate the axle B' and the surrounding rollers C, so that the rollers will be in contact with the axle along their whole length and also in contact with the inner surface of the bore.

The rollers C have cone-pointed ends, as clearly shown in Fig. 2. The front cap D has in its inner face an annular recess *d* concentric with the axis of the spindle and adapted to accommodate balls E. On the cap D is an internally-projecting boss *d'*. The height of this boss is somewhat less than the depth of the recess *d* in order that when the balls are in position in the recess the periphery of the balls may project beyond the face of the boss, so as to afford a bearing on the balls for the end of the axle. The inner face of the boss *d'* is concaved, as shown, so as to form with

the end of the axle a cavity  $d^2$ , adapted to receive oil, as clearly shown in Fig. 2. An oil-hole  $d^3$  extends through the cap and communicates with the cavity  $d^2$ . The slide  $D'$  is  
 5 connected with the front of the cap by a screw  $d^4$  or other suitable means, and the slide turns on the screw. The slide  $D'$  is L-shaped in form and has at one end a slot  $d^5$ , adapted to accommodate a set-screw  $d^6$ .

10 It is obvious that by loosening the set-screw  $d^6$  and turning the slide  $D'$  to the position indicated by dotted lines in Fig. 1 access may be readily had to the oil-hole  $d^3$ . After supplying the box with oil the slide may be  
 15 pushed back and clamped in its original position by the nut  $d^6$  and will serve to exclude dirt or grit from the box.

The inner cap  $F$  is made in two parts having a hinged connection with each other, as  
 20 shown in Fig. 2, the purpose of which I will hereinafter explain. The cap  $F$  has an internal central cavity  $f$ , corresponding in depth to the thickness of the collar  $A^2$  plus the diameter of the ball  $E$  and of the same diameter as the diameter of the bore  $B^2$ . Bolts  $G$   
 25 extend through both caps and through the hub and serve to connect the caps with the hub. The two members of the cap  $F$  turn on one of the bolts, so that the members may be  
 30 thrown apart in such manner as to enlarge the opening between the members, so that the axle with the collars attached may be inserted through the opening.

Gaskets  $H$  are interposed between the caps  
 35  $D$   $F$  and the ends of the hub. These gaskets afford simple and effective means for accurate adjustment of the caps on the hub, so that by using a gasket of greater or less thickness the length of the bore  $B^2$  plus the depth  
 40 of the cavity  $f$  may be accurately gaged to compensate for wear or for any inaccuracy in setting the collars on the axle. The rollers  $C$  are slightly shorter than the length of the bore  $B^2$ , so that normally the ends of the rollers are not in contact either with the cap  $D$   
 45 or the collar  $A^2$ .

The construction and arrangement of the parts is such that when the wheels slide inward the ends of the axle engage with the  
 50 balls  $E$  in the outer cap  $D$  and the balls receive the end-thrust of the axle. When the wheels slide in the opposite direction the collar  $A^2$  abuts against the balls  $E$  in the cap  $F$  and the balls receive the end-thrust of the  
 55 axle. An obvious practical advantage of this construction and arrangement is that the balls and the rollers are entirely independent of each other. By making the rollers  $C$  cone-pointed at both ends I reduce to the minimum  
 60 the friction arising from the contact of the ends of the rollers with the inner face of the cap  $D$  and the face of the collar  $A^2$ , thereby obviating lateral displacement of the rollers.

I am aware that cone-pointed rollers adapted to receive end-thrust have heretofore been  
 65 used; but such rollers are objectionable for that use for the reason that if there is any

considerable pressure on the ends of the rollers the cone-points either become blunted or else grind into the surface with which they  
 70 are in contact. This objection is obviated by my improvement. It will be seen that no part of the end-thrust is received by the cone-point of the rollers, except the thrust of the rollers themselves, and this is so slight that  
 75 by making the rollers with double cone-points, as shown, there will be no displacement of the rollers, nor will there be any appreciable wear on the cone-points. I am also aware that rollers have been used having grooved ends  
 80 adapted to accommodate balls interposed between the rollers. I therefore do not broadly claim the use of balls and rollers, but restrict my claims to the particular construction and arrangement of parts herein set forth. 85

The use of balls in conjunction with rollers having grooved ends or of balls interposed between rotating rollers is open to a practical objection, which I will now explain, reference being had to the diagram, Fig. 4, of the drawings. The axle  $A'$  is stationary. The wheel  
 90  $B$  revolves in the direction  $X$ . The rollers  $C$   $C^2$ , &c., being in contact with the axle  $A'$  and the bore of the wheel  $B$  all revolve in the direction  $Z$ . The balls  $E$  are interposed between and separate the rollers and run in  
 95 grooves in the rollers. The contact of the hub of the wheel  $B$  with the balls  $E$  tends to revolve the balls in the direction  $Y$ , while the contact of the rollers  $C$   $C'$  with the balls  $E$   
 100 tends to drive the balls in the opposite direction. Hence I have the force exerted by the wheel against the balls  $E$  acting against the forces exerted by both of the rollers  $C$  and  $C'$ . The result must be that the two rotative  
 105 forces of the rollers acting against the single rotative force of the wheel on the balls will drive the balls in a direction contrary to the rotative direction of the wheel, thus causing the balls to grind on the bore of the wheel,  
 110 thereby grinding grooves in the hub of the wheel, or else grinding away the balls to such extent as to permit the rollers to come together. In either case the balls cease to serve  
 115 any useful purpose.

It will be seen that with my improved construction all of the balls and all of the rollers revolve in the same direction, thereby reducing friction to the minimum, and there is no contact between the balls and the rollers  
 120 which would serve to displace either the balls or the rollers.

Another practical advantage of my improvement is this—that the rotation of the wheel in connection with gravity and the cen-  
 125 trifugal force of the wheel serves to rotate the balls in the vertical axial plane of the balls, while the engagement of the balls with the end of the axle or the face of the collar  $A^2$  serves to rotate the balls in a diametrically-  
 130 opposite direction, so that the position of the balls is constantly changing, thereby distributing the wear on the whole surface of the balls and preventing the balls from wear-

ing flat, as would be the case if they revolved always in the same direction.

I am also aware that movable slides of various forms have heretofore been employed to cover oil-holes. I therefore do not broadly claim the use of a slide for that purpose, but restrict my claims to a slide constructed and arranged substantially as herein set forth.

I am also aware that two-part caps have heretofore been used. I therefore do not broadly claim that feature, but restrict my claims to a two-part cap so constructed and arranged as to be readily attached to the hub of a wheel and adapted to accommodate rollers and a collar, as herein set forth.

Having fully described my invention, what I claim as new, and desire to secure by Letters Patent, is—

1. A wheel and an axle for vehicles, consisting of a wheel having a hub provided with a central bore; an axle in said bore; a collar secured to said axle and having opposite flat faces; cone-pointed rollers and balls bearing against opposite sides of said collar, respectively, said cone-pointed rollers surrounding said axle throughout the length of said bore; an outer cap attachable to the hub of said wheel and having an annular recess, said cap also having a face adapted to receive the end-thrust of said rollers; balls in the annular recess of said outer cap and in contact with the end of said axle; an inner cap detachably connected with the hub of said wheel, said inner cap consisting of two members having a hinge connection with each other, and also

having an internal central cavity inclosing balls in slight rolling contact with said collar; as set forth.

2. In a wheel and axle for vehicles the combination of an axle; a wheel having a central bore; rollers in said bore and surrounding the axle; an outer cap attached to the hub of the wheel and having an annular recess; balls in said annular recess; an inner cap detachably connected with the hub of the wheel and having a central cavity; said inner cap consisting of two members having a hinge connection with each other; a collar and balls in the central cavity of said inner cap; gaskets interposed between said caps and the hub of said wheel; and bolts passing through said hub, caps, and gaskets; as set forth.

3. In a wheel and axle for vehicles, a cap having a central boss concaved so as to form in conjunction with the end of the shaft an oil-cavity, and provided with an oil-hole communicating with said cavity; a slide turning on a pivot on said cap and provided with a slot; and a set-screw passing through said slot and controlling the adjustment of said slide; in combination with a wheel to which said cap is secured and an axle on which said wheel turns; as set forth.

In witness whereof I have hereunto subscribed my name, at Springfield, Illinois, this 22d day of March, 1895.

JAMES L. COOK.

Witnesses:

HENRY BUNN,  
S. C. DORWIN.