

(No Model.)

3 Sheets—Sheet 1.

W. A. McGUIRE & H. M. PERRY.
STREET SWEEPER.

No. 557,416.

Patented Mar. 31, 1896.

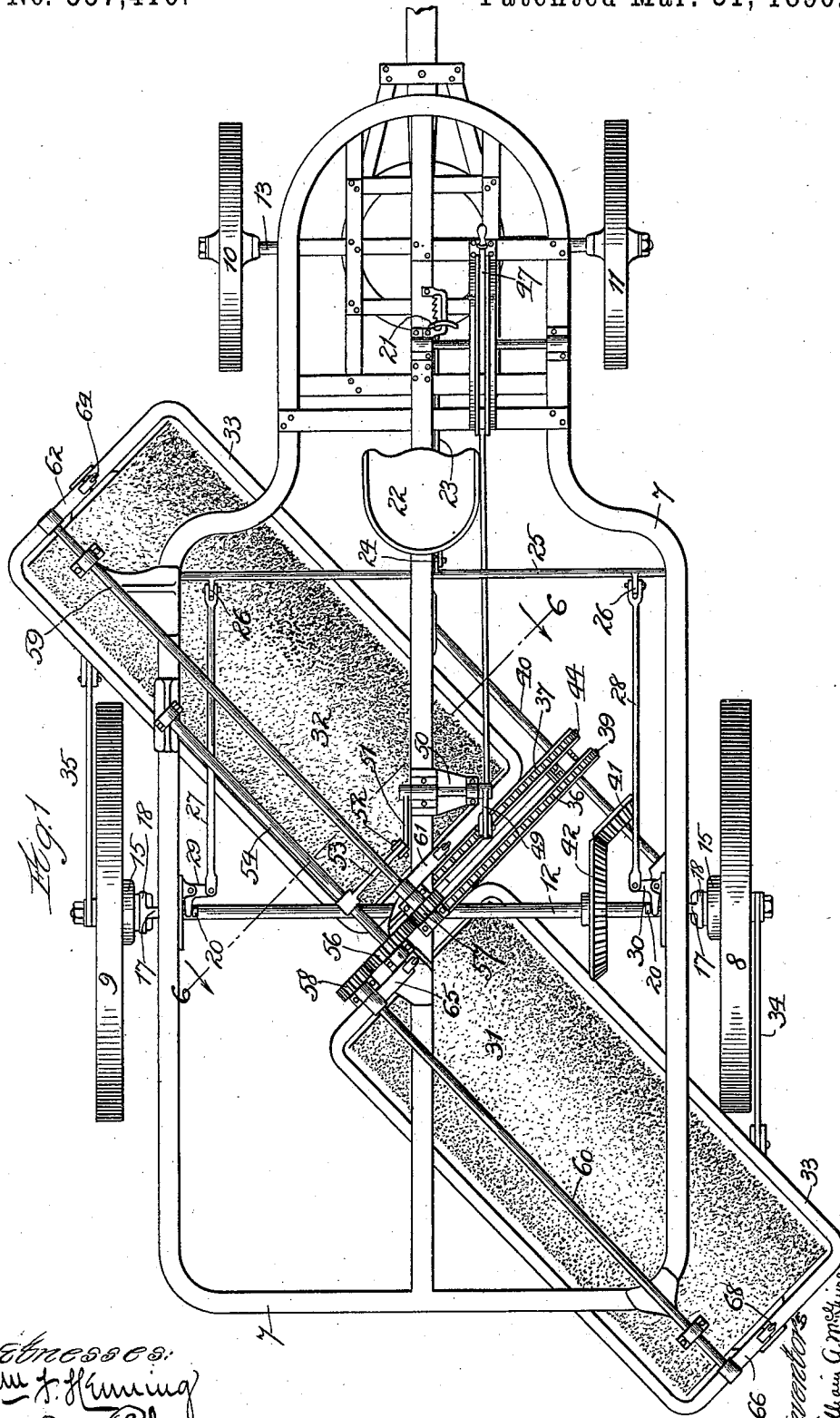

Witnesses:
Wm. J. Fleming
St. N. P. P. P.

Inventors
William A. McGuire
Hubert M. Perry
by Bond, Adams & Pleasant-Johnson, their Attys.

(No Model.)

3 Sheets—Sheet 2.

W. A. McGUIRE & H. M. PERRY.
STREET SWEEPER.

No. 557,416.

Patented Mar. 31, 1896.

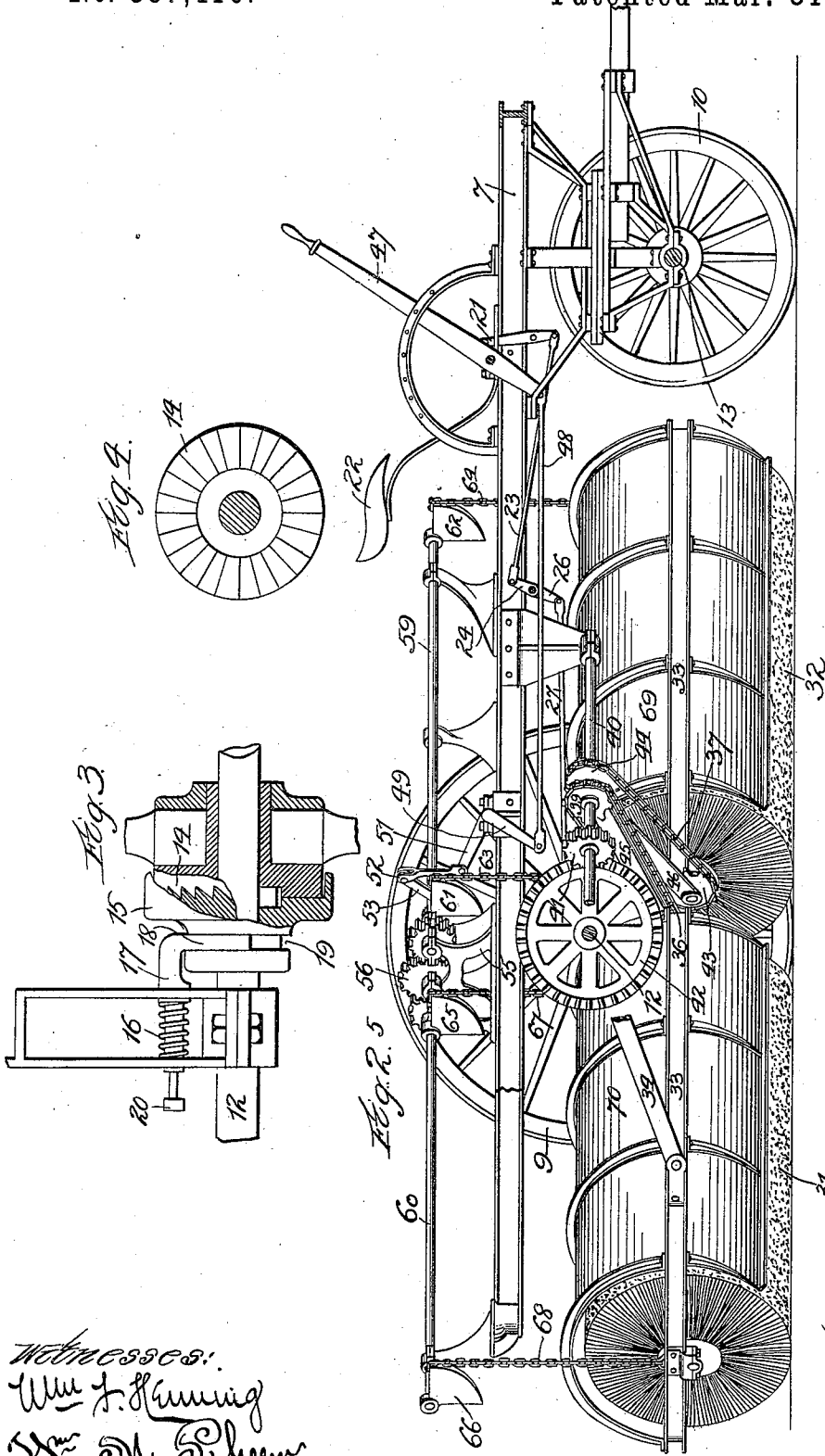

Witnesses:
Wm. L. Fleming
Geo. M. Scheer

Inventors
William A. McGuire,
Hubert M. Perry,
By George A. Richardson, Attorney

(No Model.)

3 Sheets—Sheet 3.

W. A. MCGUIRE & H. M. PERRY.
STREET SWEEPER.

No. 557,416.

Patented Mar. 31, 1896.

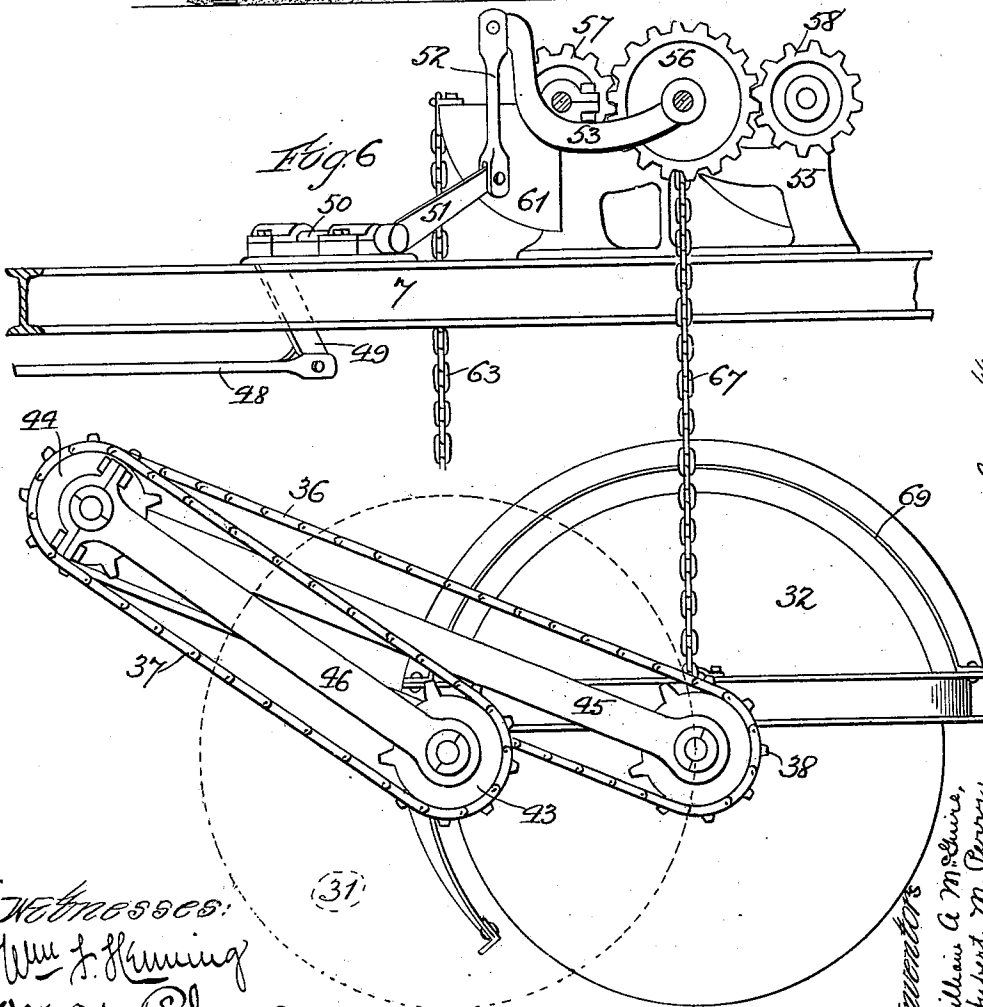
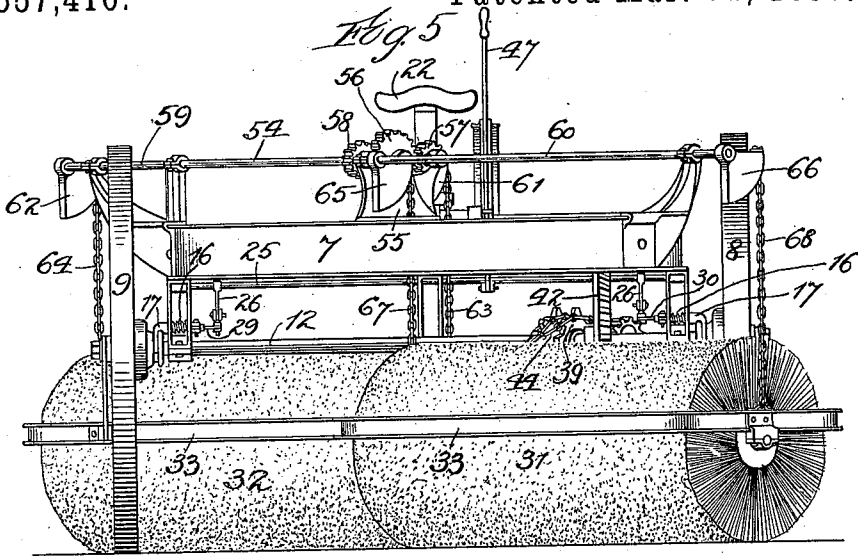

Thos. Coffey, Jr.

Inventors
William A. McGuire,
Hubert M. Perry,
by Bond, Hunsicker & Jackson.

Witnesses:
Wm. J. Fleming
H. M. PERRY

UNITED STATES PATENT OFFICE.

WILLIAM A. MCGUIRE AND HUBERT M. PERRY, OF CHICAGO, ILLINOIS, ASSIGNORS TO THE MCGUIRE MANUFACTURING COMPANY, OF SAME PLACE.

STREET-SWEEPER.

SPECIFICATION forming part of Letters Patent No. 557,416, dated March 31, 1896.

Application filed July 9, 1894. Serial No. 516,972. (No model.)

To all whom it may concern:

Be it known that we, WILLIAM A. MCGUIRE and HUBERT M. PERRY, citizens of the United States, residing at Chicago, in the county of Cook and State of Illinois, have invented certain new and useful Improvements in Street-Sweeping Machines, of which the following is a specification, reference being had to the accompanying drawings, in which—

Figure 1 is a plan view. Fig. 2 is a side elevation with parts broken away. Fig. 3 is an enlarged detail, being a partial sectional view, showing the clutch mechanism by means of which the driving-axle is operated by the drive-wheels. Fig. 4 is a face view of one of the clutch-sections. Fig. 5 is a rear elevation of the machine. Fig. 6 is an enlarged detail, being a section on line 6 6 of Fig. 1.

This invention relates to street-sweeping machines of that class in which a rotating broom or brooms are supported by a carriage and caused to rotate by the forward movement of said carriage; and it consists in certain novel improvements and combinations of parts, as hereinafter described and claimed.

In the drawings, 7 indicates the frame of the carriage, which is mounted upon rear wheels 8 9 and front wheels 10 11.

12 indicates the rear axle, and 13 indicates the front axle. The rear wheels 8 9 are journaled upon the axle 12, and have upon the inner faces of their hubs clutch-sections 14, which are adapted to be engaged by clutch-sections 15 mounted upon feathers in the axle 12 and movable longitudinally thereof. The clutch-sections 15 are normally held in engagement with the clutch-sections 14 by springs 16 mounted upon rods 17 which engage the clutch-sections 15, as shown in Fig. 3. Such engagement is preferably effected by means of yokes 18 fitting in recesses 19 in the clutch-sections 15, as shown in Fig. 3. Each rod 17 carries a collar or nut 20, as shown in Figs. 1 and 3. The clutch-sections 15 are moved out of engagement with the clutch-sections 14 by means of a foot-lever 21 mounted in the forward portion of the frame near the driver's seat 22, which lever is connected by a rod 23 to the arm 24 carried by a rock-shaft 25, as shown in Fig. 2. At each end of

the rock-shaft is an arm 26, which arms are connected by rods 27 28 to bell-crank levers 29 30, pivoted to suitable supports near the ends of the rods 17, as shown in Fig. 1. The free arms of the bell-crank levers 29 30 are adapted to engage the collars 20 when such bell-crank levers are rocked, thereby moving the rods 17 inward, and consequently moving the clutch-sections 15 out of engagement with the clutch-sections 14. By this construction the rotation of either of the brooms can be stopped or started at will, and at the same time either wheel is permitted to turn backward on the shaft independently of the other wheel.

31 32 indicate brooms which are arranged in a diagonal position under the frame 7, the axes of the brooms being parallel, and one of said brooms being arranged slightly in advance of the other, as shown in Fig. 1. The inner ends of the axes of said brooms lie in substantially the same longitudinal line, so that said brooms overlap, as best shown in Fig. 1, by which arrangement the danger of leaving an unswept strip is avoided. Each of said brooms is provided with an encircling guard-frame 33 arranged in a horizontal position, which frames carry the bearings for the axes of the brooms, as shown in Figs. 2 and 6. The frames 33 are connected to the outer ends of the spindles of the rear wheels by bars 34 35, as shown in Fig. 1.

The brooms 31 32 are rotated by the forward movement of the machine through the instrumentality of link-belts 36 37, the belt 36 passing around a sprocket-wheel 38 on the inner end of the axle of the broom 31 and around a sprocket-wheel 39 mounted on a counter-shaft 40 journaled in the frame 7, which counter-shaft is driven by means of a bevel-gear 41 from a drive-gear 42 mounted on the rear axle 12, as shown in Fig. 1. The belt 37 passes around a sprocket-wheel 43 mounted on the inner end of the axle of the broom 32 and around a sprocket-wheel 44, also mounted on the counter-shaft 40, as shown in Fig. 1. The belts 36 37 are maintained at the proper tension by bars 45 46, as shown in Fig. 6, the bar 45 extending between the sprocket-wheels 38 39 and the bar 46 extending

between the sprocket-wheels 43 44, said bars serving to prevent the respective sprocket-wheels from moving toward each other.

The brooms may be raised or lowered, as desired, by means of a lever 47 mounted in the forward portion of the frame of the machine, which lever is connected by a rod 48 to a crank-arm 49, carried by a shaft 50 suitably mounted on the frame 7. An arm 51, also connected to the shaft 50, is connected by a rod 52 to an arm 53 secured to a counter-shaft 54 journaled in suitable supports 55 rising from the frame of the machine, as shown in Fig. 6. The counter-shaft 54 carries an intermediate gear 56, which meshes with gears 57 58 arranged at opposite sides of the gear 56, as shown in Figs. 1 and 6. The gear 57 is mounted upon the inner end of a shaft 59 extending over the broom 32, which shaft 59 is mounted in suitable supports rising from the frame 7. The gear 58 is mounted on the inner end of a shaft 60 extending over the broom 31, which shaft is also mounted in suitable supports rising from the frame 7.

61 62 indicate segments which are mounted upon the shaft 59 near its opposite ends, as shown in Fig. 2.

63 64 indicate chains, the upper ends of which are attached to the upper portions of the segments 62 63, respectively, and their lower ends are connected to opposite ends of the frame 33 of the broom 32.

65 66 indicate segments which are mounted upon the shaft 60 near its opposite ends, and are connected by chains 67 68 to the opposite ends of the frame 33 of the broom 31. By this construction when the lever 47 is operated the motion will be transmitted through the gears 56 57 58 to the shafts 59 60, and the brooms will thereby be raised or lowered, depending on the direction in which the lever 47 is moved.

69 70 indicate dust-guards which are mounted on the frames 33 of the different brooms and extend partially around the

brooms, as shown in Fig. 2. The dust-guards may be made of any suitable material.

By making use of two brooms and arranging them diagonally, as described, they may be extended laterally to any desired extent for the purpose of increasing the sweep of the machine without disarranging the driving mechanism and without leaving an unswept strip at the point where the brooms meet.

That which we claim as our invention, and desire to secure by Letters Patent, is—

1. In a street-sweeping machine, the combination with a frame, and front and rear wheels thereunder, of the rear axle 12, clutch-sections 15 carried thereby, clutch-sections 14 on the inner faces of the rear-wheel hubs, springs 16 for holding said clutch-sections 15 normally in engagement with the clutch-sections 14, rods 17 having the said springs mounted thereon and provided with yokes 18 and collars 20, bell-crank levers 29 30, rock-shaft 25, connecting-rods 27 28, lever 21, and connecting-rod 23 connecting said lever to said rock-shaft, substantially as described.

2. In a street-sweeping machine, the combination with a carriage, and a broom arranged thereunder, of a shaft 59, segments 61 62 mounted on said shaft, flexible connections connecting said segments with the ends of said broom, pinion mounted upon said shaft, a counter-shaft also mounted in the frame of the machine, a pinion mounted upon said counter-shaft and meshing with the pinion mounted on the shaft 59, a lever, arm 53 carried by said counter-shaft, a shaft 50, arm 51 connected to said arm 53, arm 49 connected to said shaft 50, lever 47, and connecting-rod 48 connecting said lever to said arm 49, substantially as described.

WILLIAM A. MCGUIRE.
HUBERT M. PERRY.

Witnesses:

JOHN L. JACKSON,
A. H. ADAMS.