

(No Model.)

E. F. HILL.
BOW FOR VEHICLE TOPS.

No. 557,581.

Patented Apr. 7, 1896.

Fig. 1.

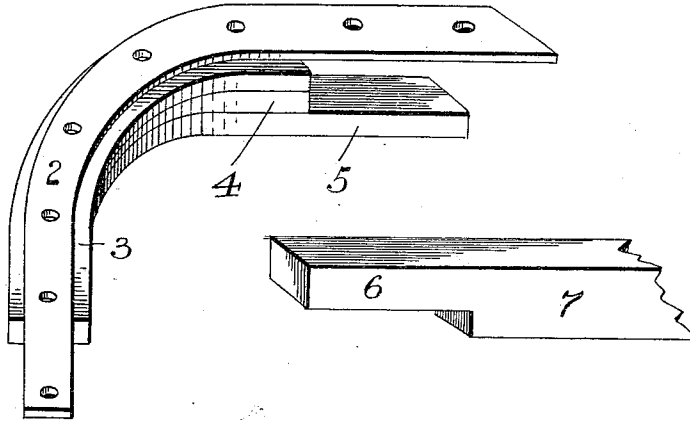

Fig. 2.

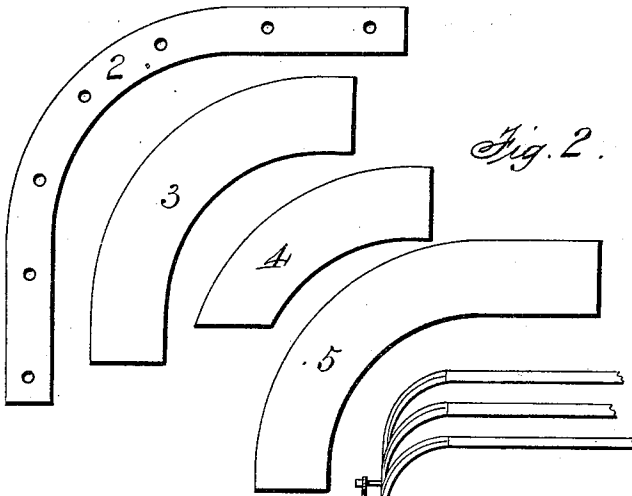
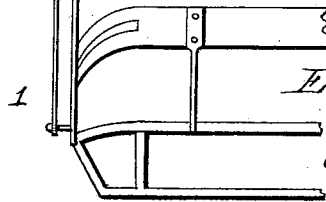

Fig. 3.



Witnesses
F. L. Curand.
A. J. Smith

Inventor
Eugene F. Hill
By *J. A. Swellson*
Attorney

UNITED STATES PATENT OFFICE.

EUGENE F. HILL, OF AUBURN, NEW YORK.

BOW FOR VEHICLE-TOPS.

SPECIFICATION forming part of Letters Patent No. 557,581, dated April 7, 1896.

Application filed November 5, 1895. Serial No. 567,988. (No model.)

To all whom it may concern:

Be it known that I, EUGENE F. HILL, a citizen of the United States, residing at Auburn, in the county of Cayuga and State of New York, have invented certain new and useful Improvements in Bows for Vehicle-Tops; and I do declare the following to be a full, clear, and exact description of the invention, such as will enable others skilled in the art to which it appertains to make and use the same.

My invention relates to improvements in the bows for buggy and other vehicle tops, and its object is to provide an improved device of this character by which I secure important advantages with respect to simplicity, economy and strength of construction, and durability and efficiency in use.

The invention consists in the novel construction and combination of parts hereinafter fully described and claimed.

In the accompanying drawings, Figure 1 is a detail perspective view of a bow for a vehicle-top constructed in accordance with my invention. Fig. 2 is an elevation showing the parts comprising the bow detached and ready to be assembled. Fig. 3 is a detail end view of a buggy-top bow extending in accordance with my invention.

In the said drawings the reference-numeral 1 designates the top-props secured to the vehicle-body and to which the bow is secured. This bow consists of a number of sections secured or connected together as follows: The numeral 2 designates a curved metal bar formed with a series of apertures. Secured to this plate is a curved wooden bar 3, having

its outer end sawed into requisite shape, the similarly-formed but shorter bar 4, and the curved outer bar 5, extending beyond the inner ends of the bars 3 and 4, forming a space to receive the reduced end 6 of a straight cross-bar 7. All of these bars are connected together by bolts or other fastening devices passing through the apertures in the metal plate 2.

By the above construction I form a sectional corner-piece which possesses many advantages over the corner-pieces in ordinary use.

Instead of making the said wooden bars 3, 4, and 5 separate and securing them together, the corner-piece may be sawed from a single block of wood having the inner end cut away to receive the reduced end of the cross-bar.

Having thus fully described my invention, what I claim is—

The combination with the metal plate having curved ends and provided with a series of apertures, of the intermediate short bars 3 and 4 having curved ends, and the outer curved bars 5, the inner ends of which extend beyond said bars 3 and 4, and the center bar 7 having reduced ends abutting against the inner ends of bars 3 and 4 and said bar located between the bar 1 and the inner ends of bar 5, substantially as described.

In testimony whereof I affix my signature in presence of two witnesses.

EUGENE F. HILL.

Witnesses:

BRADFORD COOK,
CURTIS R. MYERS.