



US00D671061S

(12) **United States Design Patent**  
**Dilber et al.**

(10) **Patent No.:** **US D671,061 S**

(45) **Date of Patent:** **\*\* Nov. 20, 2012**

(54) **WHEEL OR WHEEL COVER**

(75) Inventors: **Cengiz Dilber**, Affalterbach (DE);  
**Marian Hrabcak**, Affalterbach (DE)

(73) Assignee: **Daimler AG**, Stuttgart (DE)

(\*\*) Term: **14 Years**

(21) Appl. No.: **29/371,515**

(22) Filed: **Mar. 31, 2011**

(30) **Foreign Application Priority Data**

Oct. 1, 2010 (EM) ..... 001762436-0001

(51) **LOC (9) Cl.** ..... **12-16**

(52) **U.S. Cl.** ..... **D12/211**

(58) **Field of Classification Search** ..... D12/204–213;  
301/37.101, 64.101, 65, 64.201

See application file for complete search history.

(56) **References Cited**

**U.S. PATENT DOCUMENTS**

D375,073 S *	10/1996	Theiss	.....	D12/209
D412,479 S *	8/1999	Sacco et al.	.....	D12/209
D419,512 S *	1/2000	Sacco et al.	.....	D12/209
D419,940 S *	2/2000	Sacco et al.	.....	D12/209
D430,523 S *	9/2000	Pfeiffer	.....	D12/209
D451,458 S *	12/2001	Sacco et al.	.....	D12/209

D452,838 S *	1/2002	Hieke	.....	D12/209
D458,208 S *	6/2002	Hartl	.....	D12/211
D462,309 S *	9/2002	Hieke	.....	D12/211
D480,037 S *	9/2003	Takechi	.....	D12/211
D514,495 S *	2/2006	Hieke	.....	D12/211
D515,996 S *	2/2006	Baumgartner	.....	D12/209
D528,059 S *	9/2006	Hieke	.....	D12/209
D532,733 S *	11/2006	Hieke	.....	D12/209
D532,734 S *	11/2006	Hieke	.....	D12/209
D537,027 S *	2/2007	Hieke	.....	D12/211
D582,329 S *	12/2008	Hieke	.....	D12/209
D585,351 S *	1/2009	Hieke	.....	D12/209
D638,762 S *	5/2011	Hilpert	.....	D12/209

\* cited by examiner

*Primary Examiner* — Stacia Cadmus

(74) *Attorney, Agent, or Firm* — Crowell & Moring LLP

(57) **CLAIM**

The ornamental design for a wheel or wheel cover, as shown and described.

**DESCRIPTION**

FIG. 1 is a front view of a wheel or wheel cover according to our design; and,

FIG. 2 is a perspective view thereof.

The broken line showing of the rear of the wheel, and the bolt holes and center opening in the central hub area is included for the purpose of illustrating environment and forms no part of the claimed design.

**1 Claim, 1 Drawing Sheet**

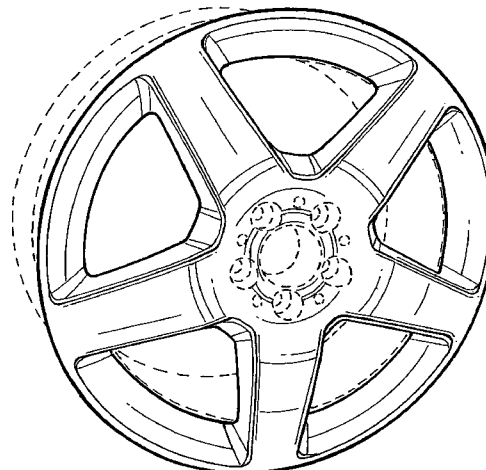
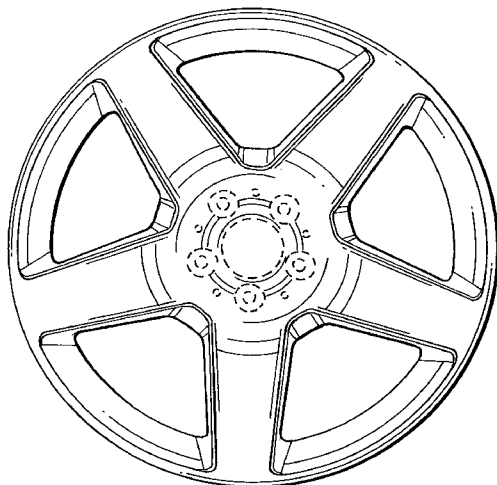

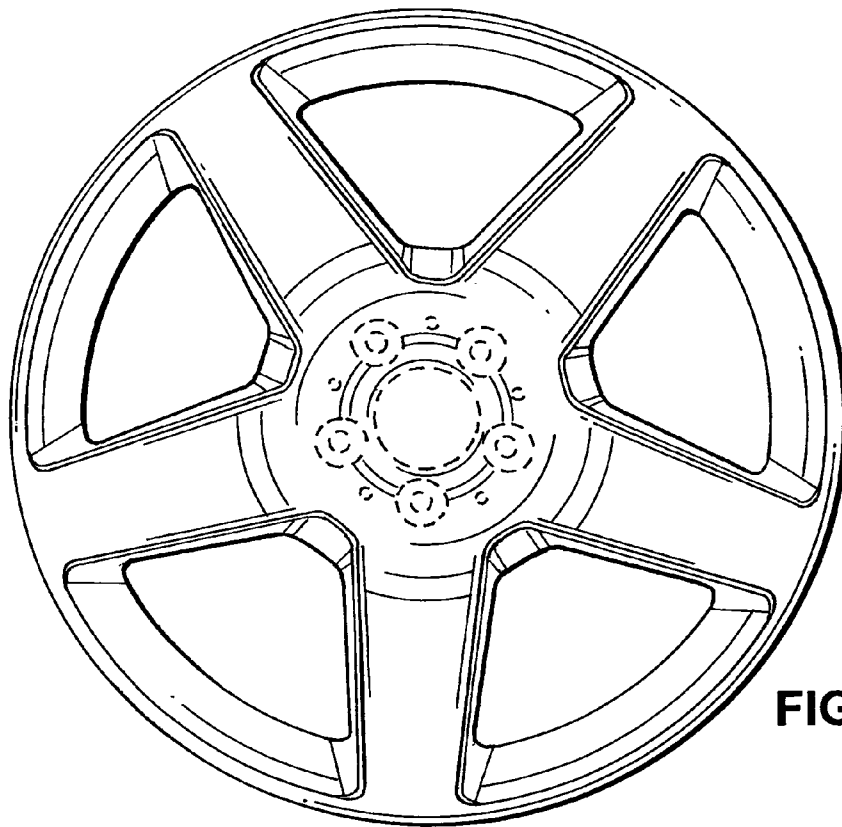

FIG. 1

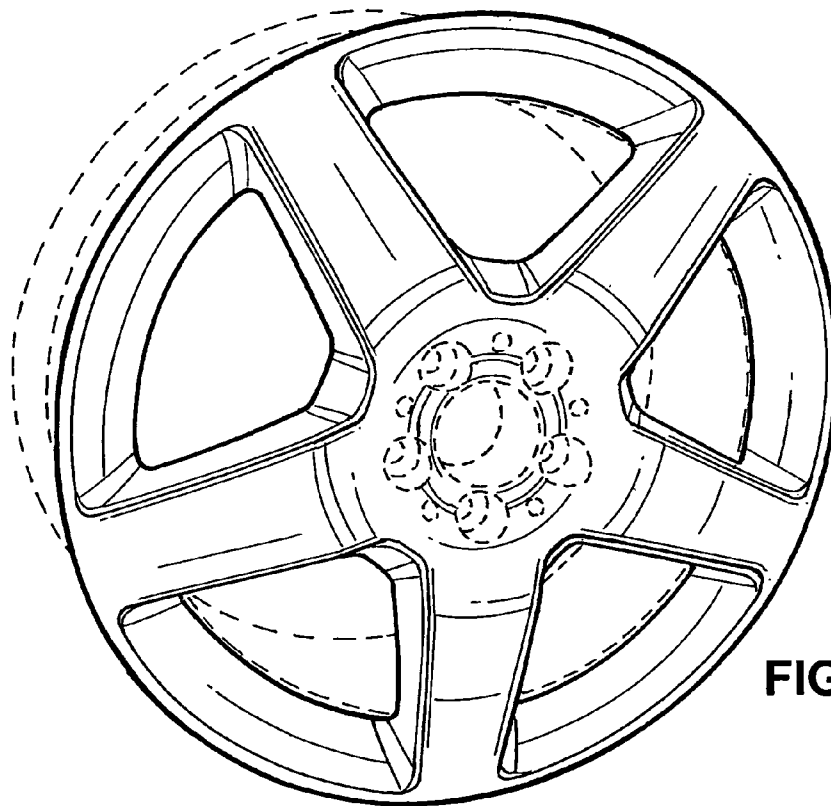

FIG. 2