

Case 438 : Narrative

Case Vehicle (A): 2000 Oldsmobile	Vehicle (B): 2002 Chevrolet
Type: Bravada, 4-door SUV	Type: Suburban, 4-door SUV
Driver: 53-year-old female	Driver: 44-year-old male
CDC: 12-FZEW-2	CDC: 99-0000-0

SITUATION

[1](#) [2](#) [3](#) On a clear night, case vehicle (A) was traveling north at a driver-estimated speed of 40 mph (64 kph) in the northbound lane of a two-lane, two-way, asphalt road, in a rural area. The road surface was dry, it was dark and unlighted, and the speed limit was 40 mph (64 kph). [4](#) Vehicle (B) was traveling south at an unknown speed in the southbound lane of the same road. As the vehicles approached each other, vehicle (B) crossed the centerline and entered the northbound lane, where the vehicles collided head-on in an offset mode. [5](#) After the impact, case vehicle (A) rotated clockwise about twenty degrees and came to rest partially off the west edge of the road, facing northeast. [6](#) [7](#) Vehicle (B) exited the east edge of the road and came to rest on the grass, facing southwest. Both vehicles were towed from the scene.

The police accident report (PAR) indicates B-level injuries for the driver and C-level injuries for the center-rear passenger of case vehicle (A), and both were transported to a local hospital where they were treated and released. The PAR indicates C-level injuries for the driver of vehicle (B) who was treated at the scene.

GENERAL VEHICLE DAMAGE AND ESTIMATED CRASH SEVERITIES

[8](#) Direct damage to case vehicle (A) began at the right-front bumper corner and extended 65-cm across the front, resulting in a 47-percent vehicle overlap (% VOL). The maximum crush was 42 cm and it occurred at the right-front bumper corner.

Vehicle (B) was not available for inspection.

[9](#) [10](#) [11](#) [12](#) [13](#) Using the missing-vehicle algorithm of the WinSMASH crash-reconstruction program and crush profiles for case vehicle (A), the following impact severities were estimated for the offset-frontal impact:

Vehicle	Variable	Estimated Velocity Change - kph (mph)		
		Total	Longitudinal	Latitudinal
Case Vehicle (A)	delta V	24 (15)	-24 (-15)	6 (4)
Vehicle (B)	delta V	21 (13)	-21 (-13)	-6 (-3)

DESCRIPTION OF DAMAGE TO CASE VEHICLE (A)

Exterior

[14](#) In the front, the majority of the rearward crush was to the right and center sections. [15](#) The bumper cover was completely separated from its attachments, [16](#) the grille and the engine components were crushed rearward, and both headlight assemblies were broken. [17](#) The hood was crushed up and to the rear and the hood latch was damaged and jammed. [18](#) The right hood hinge was bent up and to the rear, allowing the right-rear edge of the hood to contact the cowl, [20](#) which contacted and cracked the lower-right corner of the windshield. [19](#) There was no damage to the left hood hinge but the left-rear edge of the hood was elevated. [21](#) The center and left sections of the windshield were not cracked.

[22](#) On the right side, the fender was severely crumpled, pushed to the rear and bent out, and it was partially separated from its front attachments. [23](#) The front wheel was pushed rearward into the wheelwell and the lower section of the A-pillar, and the right wheelbase was reduced by 22 cm. The sidewall of the right-front tire was cut and the tire was deboned from the rim and deflated. [24](#) [25](#) There was no damage to the right-side pillars, both doors were undamaged and operational, and the right-side glazing was intact. [26](#) There was no damage to the quarter panel or [27](#) to the right-rear wheel.

[28](#) On the left side, the fender was pulled slightly to the right and buckled. [29](#) [30](#) There was no damage to the wheels and no change in the left wheelbase. [31](#) [32](#) Both doors were undamaged and operational, the left-side glazing was intact, [33](#) and the left quarter panel was undamaged. [34](#) [35](#) There was no damage to the rear of the vehicle.

Interior

[36](#) This vehicle was equipped with steering-wheel and dash-mounted frontal-impact airbags and both deployed during the frontal impact. [37](#) [38](#) The vehicle was also equipped with seatback-mounted side-impact airbags in the front seats, but they did not deploy.

In the driver area, [39](#) there was no damage to the deployed steering-wheel airbag [40](#) or to the airbag module cover. There was a [45](#) 2-cm scuffmark on the center section of the driver knee bolster and [46](#) [47](#) a 9-cm scuffmark on the right section, [40](#) [41](#) [42](#) [43](#) [44](#) [48](#) [49](#) [50](#) [51](#) but there was no other damage or contact marks in the driver area.

[52](#) [53](#) There was no damage in the center-front area and the only [54](#) [55](#) [56](#) [57](#) damage in the right-front seating area was cracks in the lower-right corner of the windshield due to contact by the cowl.

[58](#) [59](#) [60](#) [61](#) In the rear seating area, there was a scuffmark and dirt on the rear section of the center floor console between the seats, and the console cover was slightly displaced from its rear attachment.

There were no interior intrusions of interior components into the occupant space of the case vehicle.

OCCUPANT KINEMATICS AND INJURIES

[62](#) The 165-cm, 54-kg (5-ft 5-in, 118-lb) 53-year-old female driver was using [63](#) the seat-integrated three-point belt, [64](#) [65](#) but there was no evidence of belt use on the webbing or on the continuous loop, [39](#) and the steering-wheel airbag deployed. During the frontal impact, she moved forward relative to the vehicle interior, into the belt restraints, airbag, and knee bolster. She sustained a sprain to the left wrist and contusions across the left knuckles, [40](#) [43](#) possibly due to contact by the airbag and/or airbag-module cover during airbag deployment, as she was reportedly using her left hand to honk the horn just

prior to the collision. She sustained a contusion to the right knee from contact with the knee bolster, [44 45 46 47](#) as evidenced by scuffmarks on the knee bolster.

[66 67](#) The 122-cm, 23-kg (4-ft, 50-lb) 6-year-old female center-rear passenger was [68](#) using the seat-integrated 3-point belt, [69 70](#) but there was no evidence of belt use on the continuous loop. During the frontal impact, she moved forward relative to the vehicle interior into the belt restraints. She sustained an abrasion to the right side of the neck from loading by the shoulder belt.

The following tables and attached drawings [71 72](#) summarize the injuries for the two passengers.

Occupant: Driver	Age: 53 years	Gender: Female		
Restraints: Seat-integrated 3-point belt;steering-wheel airbag	Stature: 165 cm (5 ft, 5 in)	Mass: 54 kg (118 lb)		
Injury Description	A.I.S.	Injury Source		
		Definite	Probable	Possible
—	—	—	—	—
Sprain, left wrist	1	—	—	Airbag/airbag-module cover
Contusions, across left knuckles	1	—	—	Airbag/airbag-module cover
Contusion, right knee	1	Knee bolster	—	—
Maximum A.I.S. Level	1	—	—	—
Injury Severity Score	2	—	—	—

Occupant: Center rear	Age: 6 years	Gender: Female		
Restraints: Seat-integrated 3-point belt	Stature: 122 cm (4 ft)	Mass: 23 kg (50 lb)		
Injury Description	A.I.S.	Injury Source		
		Definite	Probable	Possible
—	—	—	—	—
Abrasion, right side of neck	1	Shoulder belt	—	—
Maximum A.I.S. Level	1	—	—	—
Injury Severity Score	1	—	—	—

CASE NO.: 438

CASE VEHICLE: 2000 Oldsmobile

TYPE: Bravada, 4-door SUV

OCCUPANT: (Driver) 53-year-old female

STATURE: 165 cm (5 ft, 5 in) MASS: 54 kg (118 lb)

RESTRAINTS: Seat-integrated 3-point belt;
steering-wheel airbag

SEVERITY: MAIS - 1 ISS - 2

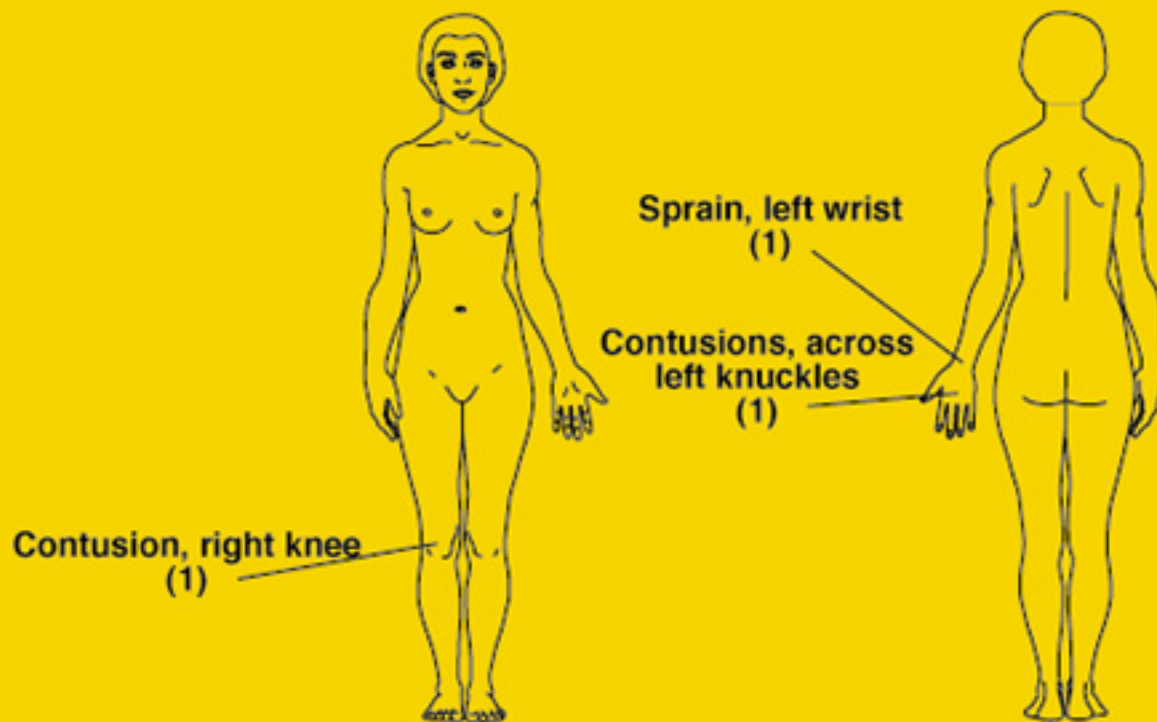

CASE NO.: 438

CASE VEHICLE: 2000 Oldsmobile

TYPE: Bravada, 4-door SUV

OCCUPANT: (Center rear) 6-year-old female

STATURE: 122 cm (4 ft) MASS: 23 kg (50 lb)

RESTRAINTS: Seat-integrated 3-point belt

SEVERITY: MAIS - 1 ISS - 1

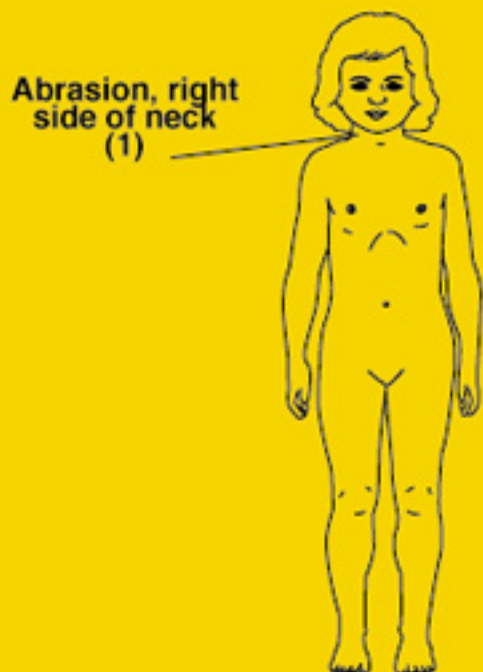

Case No.: 438
Case Veh. (A): 2000 Oldsmobile
Type: Bravada, 4-door SUV
Driver: 53-year-old female
Vehicle (B): 2002 Chevrolet Suburban, 4-door SUV

Weather: Clear
Road Surface: Dry
Road Construction: Asphalt
Light Condition: Dark/unlighted

NORTH →

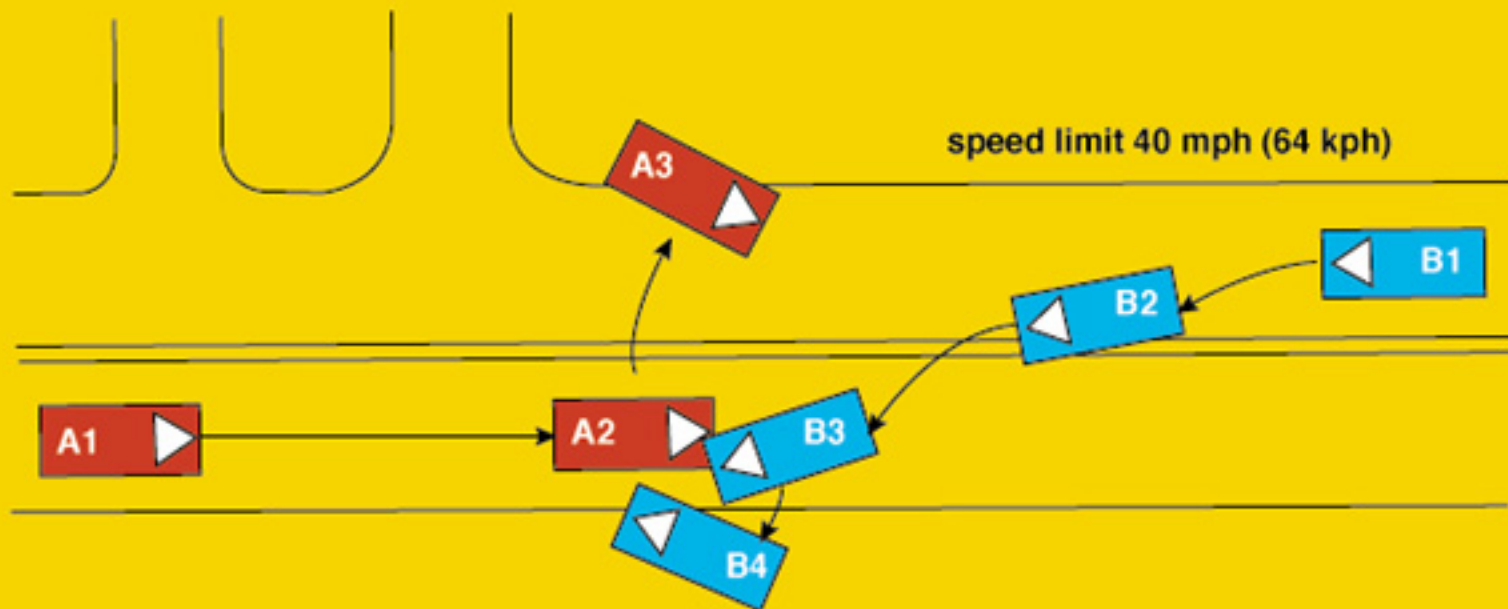

UM-4249: Vehicle Report

Click on Section Name to jump directly to that Section —

- [General Information](#)
 - [Other Vehicle](#)
 - [Case Vehicle General](#)
 - [Case Vehicle Damage Description](#)
 - [Crash Reconstruction](#)
 - [Case Vehicle Tires & Rims](#)
 - [Case Vehicle Fuel Tank](#)
 - [Case Vehicle Fuel Leakage](#)
 - [Case Vehicle Fire](#)
 - [Case Vehicle Exterior](#)
 - [Case Vehicle Steering Column/Rim](#)
 - [Case Vehicle Intrusion](#)
 - [Case Vehicle Airbag\(s\)](#)
 - [Case Vehicle Interior](#)
 - [Case Vehicle Seats](#)
 - [Case Vehicle Side Airbag\(s\)](#)
 - [EDR -- Event Data Recorder](#)
-

General Information

[Back to Top](#)

Variable Number	Variable Name	Code Value	Code Description	Other Options
V0204	Collision Hour	1810	Time of day (24 hour clock)	more
V0205	State Fips Code	26	Michigan	more
V0206	Urban/rural Area	2	Rural	more
V0207	Limited Access Highway	0	No	more
V0208	Road Total Lanes	2	2 lanes	more
V0209	Intersect Road Total Lanes	8	Not applicable	more
V0210	Trafficway Flow	0	Not physically divided - two way traffic	more
V0211	Road Surface Type	1	Asphalt	more
V0212	Road Defects	0	No	more
V0213	Construction Zone	0	No	more
	Road Alignment Vertical			

V0214	Plane	1	Level	more
V0215	Road Alignment Horizontal Plane	1	Straight	more
V0216	Surface Covering	10	Dry	more
V0217	Visibility Limitation	0	None	more
V0218	Visibility Obstruction	0	None	more
V0219	Speed Limit	3	61-70 km/h .. 40 mph	more
V0220	Precipitation Type	0	None	more
V0221	Precipitation Rate	8	Not applicable	more
V0222	Temperature	9	Unknown	more
V0223	Crosswind	9	Unknown	more
V0224	Light Conditions	5	Dark, unlighted	more
V0225	Mechanical Malfunction Mention	0	No	more
V0226	Case Vehicle And Object	0	No	more
V0227	Case Vehicle Rollover	0	No	more
V0228	Rollover Location	0	No rollover	more
V0229	Roll Direction	0	No rollover	more
V0230	Rollover Initiation Type	0	No rollover	more
V0231	Rollover Number Of Turns	0	No rollover	more
V0232	Case Vehicle Preimpact Braking	0	No	more
V0233	Case Vehicle Preimpact Stability	1	Case vehicle tracking before impact	more
V0234	Case Vehicle Ran Off Roadway	0	No	more
V0235	Moving Case Vehicle Contacted Moving Vehicle	1	Yes	more
V0236	Case Vehicle Contacted Stopped Vehicle	0	No	more
V0237	Stopped Case Vehicle Contacted Vehicle	0	No	more
V0238	Total Vehicles Hit By Case Vehicle	1	1 vehicle	more
V0239	Any Fire In Crash?	0	No	more
V0240	Maximum Police Severity-acc	2	B - Non-Incapacitating Injury	more
V0241	Driver Alcohol Involvmnt	0	Had not been drinking	more
V0242	Driver Alcohol BAC (Case Vehicle)	80	No test	more
V0243	Driver Impairment Mention	0	No	more

V0244	Driver Distraction	01	Attentive or not distracted	more
V0245	Driver Drug Involvement	0	None	more
V0246	Driver Drug Type	0	No drug use	more
V0247	Driven/towed From Scene	2	Towed Due to Damage	more

Other Vehicle

[Back to Top](#)

Variable Number	Variable Name	Code Value	Code Description	Other Options
V0301	Other Vehicle VIN	3GNFK16Z02XXXXXX	Click for Contacted Vehicle figure	more
V0302	Other Vehicle Manufacturer/Body Code	94115	—	—
V0303	Other Vehicle Manufacturer	941	General Motors	more
V0304	Other Vehicle Body Code	15	Long wheelbase utility vehicle (Carryall, Suburb	more
V0305	Other Vehicle Make/model	2903	Suburban Carryall 1/2 ton	more
V0306	Other Vehicle Model Year	2002	Year	more
V0307	Other Vehicle Mass	002424 kg	Mass (Kg.)	more
V0308	Other Vehicle Number	0	No separate report	more
V0309	Other Vehicle Number of Occupants	01	number of occupants	more
V0310	Other Vehicle Traveling Speed	999	Unknown	more
V0311	Highest Police Injury Severity	1	C - Possible Injury	more
V0312	Other Vehicle Type	15	Large utility (wheelbase >107", e.g. Suburban)	more
V0313	Other Vehicle Wheelbase in Centimeters	330 cm	Actual Wheelbase (cm)	more
V0314	Other Vehicle Average Track Width	167 cm	actual measurement (cm)	more
V0315	Other Vehicle Overall Length	559 cm	actual measurement (cm)	more
V0316	Other Vehicle Overall Width (OAW)	200 cm	actual measurement (cm)	more
	Other Vehicle Front			

V0317	Overhang	096 cm	actual measurement (cm)	more
V0318	Other Vehicle Rear Overhang	133 cm	actual measurement (cm)	more
V0319	Other Vehicle Undeformed End Width (UEW)	170 cm	actual measurement (cm)	more
V0320	Other Vehicle Engine Displacement	5.3 l	Liters	more
V0321	Other Vehicle Engine: Number of Cylinders	08	number of cylinders	more
V0322	Other Vehicle Direct Damage Length (DDL)	999	Unknown	more
V0323	Other Vehicle Front-End Overlap	99	Missing or Not applicable	more
V0324	Other Vehicle - Vehicle Overlap	99	Missing or Not applicable	more

Case Vehicle General

[Back to Top](#)

Variable Number	Variable Name	Code Value	Code Description	Other Options
V0401	VIN	1GHDT13S52XXXXXXX	Click for Case Vehicle figure	more
V0402	Manufacturer/Body Code	11415	—	—
V0403	Vehicle Manufacturer	114	Oldsmobile	more
V0404	Vehicle Body Code	15	Long wheelbase utility vehicle (Carryall, Suburb	more
V0405	Make/model Code	0668	Bravada SUV	more
V0406	Model Year	2000	Model year	more
V0407	Vehicle Mass	002099 kg	Mass (Kg)	more
V0408	Odometer Reading	888888	—	—
V0409	Number of Occupants	02	2 occupants	more
V0410	Traveling Speed	064 kph	Speed (km/h)	more
V0411	Body Type	22	Large utility (e.g. Suburban)	more
V0412	Stolen Vehicle	8	Not currently collected	more
V0413	Body Structure	2	Unitized	more
V0414	Transmission Type	2	Manual	more
V0415	Transmission Lever Location	2	Console	more
V0416	Steering	1	Power	more

V0417	Brakes	1	Power	more
V0418	Brake Type	3	Disc - all wheels	more
V0419	Adjustable Pedals?	0	No	more
V0420	Brake Anti-lock Device	2	Four-wheel	more
V0421	Air Conditioning in Vehicle	8	Not currently collected	more
V0422	Drive Type	4	All wheel drive	more
V0423	Dual Rear Wheels	0	No	more
V0424	Original Restraint System Type	3	Air bag	more
V0425	Equipped With Roll Bar	0	No	more
V0426	Roof Type	1	Solid	more
V0427	Case Vehicle Wheelbase in Centimeters	287 cm	Actual Wheelbase	more
V0428	Anti-lacerative Glass	8	Not Collected	more
V0429	Case Vehicle average track Width	158 cm	actual measurement (cm)	more
V0430	Case Vehicle Overall Length	487 cm	actual measurement (cm)	more
V0431	Case Vehicle Overall Width (OAW)	192	actual measurement (cm)	more
V0432	Case Vehicle Front Overhang	090 cm	actual measurement (cm)	more
V0433	Case Vehicle Rear Overhang	110 cm	actual measurement (cm)	more
V0434	Case Vehicle Undeformed End Width (UEW)	140 cm	actual measurement (cm)	more
V0435	Case Vehicle Engine Displacement	4.2 l	Liters	more
V0436	Case Vehicle Engine: Number of Cylinders	06	number of cylinders	more
V0437	Case Vehicle Direct Damage Length (DDL)	065 cm	actual measurement (cm)	more
V0438	Case Vehicle Front-end Overlap	46	percentage (%)	more
V0439	Case Vehicle - Vehicle Overlap	47	percentage (%)	more

Case Vehicle Damage Description

[Back to Top](#)

Variable Number	Variable Name	Code Value	Code Description	Other Options
V0501	Maximum Sheet Metal Crush - Front	042 cm	Depth of Crush (cm)	more
V0502	Maximum Sheet Metal Crush - Rear	000 cm	No Crush (or less than 1 cm.)	more
V0503	Maximum Sheet Metal Crush - Roof	000 cm	No Crush (or less than 1 cm.)	more
V0504	Maximum Sheet Metal Crush - Right Side	000 cm	No Crush (or less than 1 cm.)	more
V0505	Maximum Sheet Metal Crush - Left Side	000 cm	No Crush (or less than 1 cm.)	more
V0506	Maximum Sheet Metal Crush - Other	000 cm	No Crush (or less than 1 cm.)	more
V0507	Seq In Chronological Ord	1	Yes	more
V0508	Event 1 -impact Location	1	On Roadway	more
V0509	Event 1 -Impact Configuration	11	FRONT of case veh - FRONT of contacted veh	more
V0510	Event 1 -Object/Vehicle Contactd	15	Large utility (wheelbase >107", e.g. Suburban)	more
V0511	Event 2 -impact Location	8	No 2nd event	more
V0512	Event 2 -Impact Configuration	88	No 2nd event	more
V0513	Event 2 -Object/Vehicle Contactd	00	No object/vehicle contacted	more
V0514	Event 3 -impact Location	8	No 3rd event	more
V0515	Event 3 -Impact Configuration	88	No 3rd event	more
V0516	Event 3 -Object/Vehicle Contactd	00	No object/vehicle contacted	more
V0517	Event 4 -impact Location	8	No 4th event	more
V0518	Event 4 -Impact Configuration	88	No 4th event	more
V0519	Event 4 -Object/Vehicle Contactd	00	No object/vehicle contacted	more
V0520	Event 5 -impact Location	8	No 5th event	more
V0521	Event 5 -Impact Configuration	88	No 5th event	more
V0522	Event 5 -Object/Vehicle Contactd	00	No object/vehicle contacted	more

V0523	Event 6 -impact Location	8	No 6th event	more
V0524	Event 6 -Impact Configuration	88	No 6th event	more
V0525	Event 6 -Object/Vehicle Contactd	00	No object/vehicle contacted	more
V0526	Event 7 -impact Location	8	No 7th event	more
V0527	Event 7 -Impact Configuration	88	No 7th event	more
V0528	Event 7 -Object/Vehicle Contactd	00	No object/vehicle contacted	more
V0529	Primary CDC Case Vehicle - event Number	1	Event 1	more
V0530	Primary CDC Case Vehicle - Impact Speed (kph)	999	Unknown	more
V0531	Primary CDC Case Vehicle- estimatr	1	Investigator	more
V0532	Primary CDC Case Vehicle - Crush (CM)	042	Crush measurements in cm	more
V0533	Primary CDC Case Vehicle- clock #1	12	12 o'clock	more
V0534	Primary CDC Case Vehicle- Letter 1 #1	06	F - Front	more
V0535	Primary CDC Case Vehicle- Letter 2 #1	26	Z - Side or end (B + P or R + C)	more
V0536	Primary CDC Case Vehicle- Letter 3 #1	05	E - Everything below belt line	more
V0537	Primary CDC Case Vehicle- Letter 4 #1	23	W - Wide impact area	more
V0538	Primary CDC Case Vehicle - Extent #1	2	—	—
V0539	Primary CDC - Contacted Vehicles Assoc CDC - CDC #1	12FZEW2	—	—
V0540	Primary CDC Case Vehicle- clock #2	98	Not Applicable	more
V0541	Primary CDC Case Vehicle- Letter 1 #2	00	Missing Data/Not applicable	more
V0542	Primary CDC Case Vehicle- Letter 2 #2	00	Missing Data/Not applicable	more
V0543	Primary CDC Case Vehicle- Letter 3 #2	00	Missing Data/Not applicable	more
V0544	Primary CDC Case Vehicle- Letter 4 #2	00	Missing Data/Not applicable	more

V0545	Primary CDC Case Vehicle - Extent #2	0	—	—
V0546	Primary CDC - Case Vehicle Assoc CDC - CDC #2	9800000	—	—
V0547	Primary CDC Contacted Vehicle - Impact Speed (kph)	999	Unknown	more
V0548	Primary CDC Contacted Vehicle-estimator	1	Investigator	more
V0549	Primary CDC Contacted Vehicle - Crush (CM)	999	Unknown	more
V0550	Primary CDC Contacted Vehicle-clock #1	99	Unknown or no damage	more
V0551	Primary CDC Contacted Vehicle-Letter 1 #1	00	Missing Data/Not applicable	more
V0552	Primary CDC Contacted Vehicle-Letter 2 #1	00	Missing Data/Not applicable	more
V0553	Primary CDC Contacted Vehicle-Letter 3 #1	00	Missing Data/Not applicable	more
V0554	Primary CDC Contacted Vehicle-Letter 4 #1	00	Missing Data/Not applicable	more
V0555	Primary CDC Contacted Vehicle - Extent #1	0	—	—
V0556	primary CDC - Contacted Vehicles Assoc CDC - CDC #1	9900000	—	—
V0557	Primary CDC Contacted Vehicle-clock #2	99	Unknown or no damage	more
V0558	Primary CDC Contacted Vehicle-Letter 1 #2	00	Missing Data/Not applicable	more
V0559	Primary CDC Contacted Vehicle-Letter 2 #2	00	Missing Data/Not applicable	more
V0560	Primary CDC Contacted Vehicle-Letter 3 #2	00	Missing Data/Not applicable	more
V0561	Primary CDC Contacted Vehicle-Letter 4 #2	00	Missing Data/Not applicable	more
V0562	Primary CDC Contacted Vehicle - Extent #2	0	—	—
V0563	Primary CDC - Contacted Vehicles Assoc CDC - CDC #2	9900000	—	—
V0564	Secondary CDC Case Vehicle-event No	8	Not applicable	more

V0565	Secondary CDC Case Vehicle - Impact Speed (kph)	998	Not Applicable	more
V0566	Secondary CDC Case Vehicle-estimator	8	Not applicable (no vehicle/no impact)	more
V0567	Secondary CDC Case Vehicle - Crush (CM)	998	Not Applicable	more
V0568	Secondary CDC Case Vehicle-clock #1	98	Not Applicable	more
V0569	Secondary CDC Case Vehicle-Letter 1 #1	00	Missing Data/Not applicable	more
V0570	Secondary CDC Case Vehicle-Letter 2 #1	00	Missing Data/Not applicable	more
V0571	Secondary CDC Case Vehicle-Letter 3 #1	00	Missing Data/Not applicable	more
V0572	Secondary CDC Case Vehicle-Letter 4 #1	00	Missing Data/Not applicable	more
V0573	SECONDARY CDC CASE VEHICLE - EXTENT #1	0	—	—
V0574	Secondary CDC - Case Vehicle Assoc CDC - CDC #1	9800000	—	—
V0575	Secondary CDC Case Vehicle-clock #2	98	Not Applicable	more
V0576	Secondary CDC Case Vehicle-Letter 1 #2	00	Missing Data/Not applicable	more
V0577	Secondary CDC Case Vehicle-Letter 2 #2	00	Missing Data/Not applicable	more
V0578	Secondary CDC Case Vehicle-Letter 3 #2	00	Missing Data/Not applicable	more
V0579	Secondary CDC Case Vehicle-Letter 4 #2	00	Missing Data/Not applicable	more
V0580	SECONDARY CDC CASE VEHICLE - EXTENT #2	0	—	—
V0581	Secondary CDC - Case Vehicle Assoc CDC - CDC #2	9800000	—	—
V0582	Secondary CDC Contacted Vehicle - Impact Speed (kph)	998	Not Applicable	more
V0583	Secondary CDC Contacted Vehicle-estimator	8	Not applicable (no vehicle/no impact)	more
V0584	Secondary CDC Contacted Vehicle - Crush (CM)	998	Not Applicable	more
	Secondary CDC Contacted			

V0585	Vehicle-clock #1	98	Not Applicable	more
V0586	Secondary CDC Contacted Vehicle-Letter 1 #1	00	Missing Data/Not applicable	more
V0587	Secondary CDC Contacted Vehicle-Letter 2 #1	00	Missing Data/Not applicable	more
V0588	Secondary CDC Contacted Vehicle-Letter 3 #1	00	Missing Data/Not applicable	more
V0589	Secondary CDC Contacted Vehicle-Letter 4 #1	00	Missing Data/Not applicable	more
V0590	Secondary CDC Contacted Vehicle - Extent #1	0	—	—
V0591	Secondary CDC - Contacted Vehicle Assoc CDC - CDC #1	9800000	—	—
V0592	Secondary CDC Contacted Vehicle-clock #2	98	Not Applicable	more
V0593	Secondary CDC Contacted Vehicle-Letter 1 #2	00	Missing Data/Not applicable	more
V0594	Secondary CDC Contacted Vehicle-Letter 2 #2	00	Missing Data/Not applicable	more
V0595	Secondary CDC Contacted Vehicle-Letter 3 #2	00	Missing Data/Not applicable	more
V0596	Secondary CDC Contacted Vehicle-Letter 4 #2	00	Missing Data/Not applicable	more
V0597	Secondary CDC Contacted Vehicle - Extent #2	0	—	—
V0598	Secondary CDC - Contacted Vehicle Assoc CDC - CDC #2	9800000	—	—

Crash Reconstruction

[Back to Top](#)

Variable Number	Variable Name	Code Value	Code Description	Other Options
V0601	Primary Delta-V Case Vehicle-event #	1	Event number 1	more
V0602	Primary Delta V Case Vehicle - Total Delta V	024 kph	kph	more
V0603	Primary delta-V Case Vehicle -LONGITUD	-024	—	—
V0604	Primary delta-V Case Vehicle-Lateral	0006	—	—

V0605	Primary Delta V Case Vehicle - Energy Dissipated by Crush (k	0062	—	—
V0606	Primary Delta-V Case Vehicle-Reconstruction	22	Reconstructed, moderate confidence level	more
V0607	Primary Delta-V Case Vehicle- Mode	2	CDC & detailed damage	more
V0608	Primary Delta V Contacted Vehicle - Total Delta V	021 kph	kph	more
V0609	Primary delta-V Contacted Vehicle-LONGITUD	-021	—	—
V0610	Primary delta-V Contacted Vehicle-Lateral	-006	—	—
V0611	Primary delta-V Contacted Vehicle - Energy Dissipated by Cru	0053	—	—
V0612	Secondary Delta-V Case Vehicle-event #	8	Not applicable	more
V0613	Secondary Delta V Case Vehicle - Total Delta V	888	Not applicable	more
V0614	Secondarydelta-V Case Vehicle -LONGITUD	8888	—	—
V0615	Secondary delta-V Case Vehicle-Lateral	8888	—	—
V0616	Secondary delta-V Case Vehicle - Energy Dissipated by Crush	8888	—	—
V0617	Secondary Delta-V Case Vehicle-Reconstruction	88	Not applicable	more
V0618	Secondary Delta-V Case Vehicle- Mode	8	Not applicable	more
V0619	Secondary Delta V Contacted Vehicle - Total Delta V	888	Not applicable	more
V0620	Secondary delta-V Contacted Vehicle-LONGITUD	8888	—	—
V0621	Secondary delta-V Contacted Vehicle-Lateral	8888	—	—
V0622	Secondary delta-V Contacted Vehicle - Energy Dissipated By C	8888	—	—
	Primary EBS Case Vehicle-			

V0623	event #	1	Event number 1	more
V0624	Primary EBS Case Vehicle - Total EBS	024 kph	kph	more
V0625	Primary EBS Case Vehicle - LONGITUD	-024	—	—
V0626	Primary EBS Case Vehicle-Lateral	0006	—	—
V0627	Primary EBS Case Vehicle - Energy Dissipated by Crush (kj)	0062	—	—
V0628	Primary EBS Case Vehicle-Reconstruction	22	Reconstructed, moderate confidence level	more
V0629	Primary EBS Case Vehicle-Mode	2	CDC & detailed damage	more
V0630	Primary EBS Contacted Vehicle - Total EBS	021 kph	kph	more
V0631	Primary EBS Contacted Vehicle-LONGITUD	-021	—	—
V0632	Primary EBS Contacted Vehicle-Lateral	-006	—	—
V0633	Primary EBS Contact Vehicle - Energy Dissipated by Crush (kj)	0053	—	—
V0634	Secondary EBS Case Vehicle-event #	8	Not applicable	more
V0635	Secondary EBS Case Vehicle - Total EBS	888	Not Applicable	more
V0636	Secondary EBS Case Vehicle -LONGITUD	8888	—	—
V0637	Secondary EBS Case Vehicle-Lateral	8888	—	—
V0638	Secondary EBS Case Vehicle - Energy Dissipated by Crush (kj)	8888	—	—
V0639	Secondary EBS Case Vehicle-Reconstruction	88	Not applicable	more
V0640	Secondary EBS Case Vehicle- Mode	8	Not applicable	more
V0641	Secondary EBS Contacted Vehicle - Total EBS	888	Not Applicable	more
V0642	Secondary EBS Contacted Vehicle-LONGITUD	8888	—	—

V0643	Secondary EBS Contacted Vehicle-Lateral	8888	—	—
V0644	Secondary EBS Contact Vehicle - Energy Dissipated by Crush (8888	—	—
V0645	Specific Event # Case(1)	1	Event number 1	more
V0646	Plane of Impact Case Vehicle (1)	1	Bumper	more
V0647	Direct Damage Length (DDL) - Case Vehicle (1)	065 cm	cm	more
V0648	Direct Damage Maximum Crush - Case Vehicle (1)	042 cm	cm	more
V0649	Direct and Induced Damage Length in CM	133 cm	cm	more
V0650	Field C1 - Case Vehicle (1)	000 cm	No Crush	more
V0651	Field C2 - Case Vehicle (1)	000 cm	No Crush	more
V0652	Field C3 - Case Vehicle (1)	014 cm	cm	more
V0653	Field C4 - Case Vehicle (1)	026 cm	cm	more
V0654	Field C5 - Case Vehicle (1)	033 cm	cm	more
V0655	Field C6 - Case Vehicle (1)	042 cm	cm	more
V0656	Direct Damage D Value = The Center of Direct Damage Offset t	+034 cm	Offset (cm)	more
V0657	Specific Event # Case(2)	1	Event number 1	more
V0658	Plane of Impact Case Vehicle(2)	1	Bumper	more
V0659	Direct Damage Length (DDL) - Case Vehicle (2)	065 cm	cm	more
V0660	Direct Damage MaximumCrush - Case Vehicle (2)	042 cm	cm	more
V0661	Direct and Induced Damage Length in CM	133 cm	cm	more
V0662	Field C1 - Case Vehicle (2)	000 cm	No Crush	more
V0663	Field C2 - Case Vehicle (2)	000 cm	No Crush	more
V0664	Field C3 - Case Vehicle (2)	014 cm	cm	more
V0665	Field C4 - Case Vehicle (2)	026 cm	cm	more
V0666	Field C5 - Case Vehicle (2)	033 cm	cm	more
V0667	Field C6 - Case Vehicle (2)	042 cm	cm	more
V0668	Direct Damage D Value = The Center of Direct	+034 cm	cm	more

	Damage Offset t			
V0669	Specific Event # Cont(1)	1	Event number 1	more
V0670	Plane of Impact Contacted Vehicle(1)	9	Unknown	more
V0671	Direct Damage Length (DDL) - Contacted Vehicle (1)	999	Unknown	more
V0672	Direct Damage Maximum Crush - Contacted Vehicle (1)	999	Unknown	more
V0673	Field L - Contacted Vehicle (1)	999	Unknown	more
V0674	Field C1 - Contacted Vehicle (1)	999	Unknown	more
V0675	Field C2 - Contacted Vehicle (1)	999	Unknown	more
V0676	Field C3 - Contacted Vehicle (1)	999	Unknown	more
V0677	Field C4 - Contacted Vehicle (1)	999	Unknown	more
V0678	Field C5 - Contacted Vehicle (1)	999	Unknown	more
V0679	Field C6 - Contacted Vehicle (1)	999	Unknown	more
V0680	Direct Damage D Value = The Center of Direct Damage Offset t	+999 cm	offset (cm)	more
V0681	Specific Event # Contacted Vehicle (2)	1	Event number	more
V0682	Plane of Impact Contacted Vehicle(2)	9	Unknown	more
V0683	Direct Damage Length (DDL) - Contacted Vehicle (2)	999	Unknown	more
V0684	Direct Damage Maximum Crush - Contacted Vehicle (2)	999	Unknown	more
V0685	Direct and Induced Damage Length in CM	999	Unknown	more
V0686	Field C1 - Contacted Vehicle (2)	999	Unknown	more
V0687	Field C2 - Contacted Vehicle (2)	999	Unknown	more
	Field C3 - Contacted Vehicle			

V0688	(2)	999	Unknown	more
V0689	Field C4 - Contacted Vehicle (2)	999	Unknown	more
V0690	Field C5 - Contacted Vehicle (2)	999	Unknown	more
V0691	Field C6 - Contacted Vehicle (2)	999	Unknown	more
V0692	Direct Damage D Value = The Center of Direct Damage Offset t	+999 cm	Offset (cm)	more

Case Vehicle Tires & Rims

[Back to Top](#)

Variable Number	Variable Name	Code Value	Code Description	Other Options
V0701	Left Front Wheel Damaged	0	No	more
V0702	Right Front Wheel Damaged	1	Yes	more
V0703	Right Rear Wheel Damaged	0	No	more
V0704	Left Rear Wheel Damaged	0	No	more
V0705	Left Front Tire Tread Type	4	All Weather	more
V0706	Right Front Tire Tread Type	4	All Weather	more
V0707	Right Rear Tire Tread Type	4	All Weather	more
V0708	Left Rear Tire Tread Type	4	All Weather	more
V0709	Left Front Carcass Construction	3	Radial	more
V0710	Right Front Carcass Construction	3	Radial	more
V0711	Right Rear Carcass Construction	3	Radial	more
V0712	Left Rear Carcass Construction	3	Radial	more
V0713	Left Front Tire Condition Precrash	0	Normal - no pre-crash problems	more
V0714	Right Front Tire Condition Precrash	0	Normal - no pre-crash problems	more
V0715	Right Rear Tire Condition Precrash	0	Normal - no pre-crash problems	more
V0716	Left Rear Tire Condition Precrash	0	Normal - no pre-crash problems	more
	Left Front Tire Condition			

V0717	Postcrash	0	Normal - no damage to tire	more
V0718	Right Front Tire Condition Postcrash	0	Normal - no damage to tire	more
V0719	Right Rear Tire Condition Postcrash	0	Normal - no damage to tire	more
V0720	Left Rear Tire Condition Postcrash	0	Normal - no damage to tire	more
V0721	Left Front Tire Involvement	0	No	more
V0722	Right Front Tire Involvement	0	No	more
V0723	Right Rear Tire Involvement	0	No	more
V0724	Left Rear Tire Involvement	0	No	more
V0725	Left Front Tire Size	P25560R17	—	—
V0726	Right Front Tire Size	P25506R17	—	—
V0727	Right Rear Tire Size	P25560R17	—	—
V0728	Left Rear Tire Size	P25560R17	—	—
V0729	Left Front Tire Pressure (recorded in psi)	33.0 psi	Actual tire pressure in psi	more
V0730	Right Front Tire Pressure (recorded in psi)	00.0 psi	Actual tire pressure in psi	more
V0731	Right Rear Tire Pressure (recorded in psi)	32.0 psi	Actual tire pressure in psi	more
V0732	Left Rear Tire Pressure (recorded in psi)	33.0 psi	Actual tire pressure in psi	more
V0733	Left Front Tread Depth	09	09/32"	more
V0734	Right Front Tread Depth	09	09/32"	more
V0735	Right Rear Tread Depth	09	09/32"	more
V0736	Left Rear Tread Depth	09	09/32"	more

Case Vehicle Fuel Tank

[Back to Top](#)

Variable Number	Variable Name	Code Value	Code Description	Other Options
V0801	Propulsive Fuel Type	1	Gasoline	more
V0802	Main Tank Location	322	Within frame/centered laterally - within vertical	more
V0803	Main Filler Cap Location	113	Left of frame laterally - above vertically	more
V0804	Main Tank Material	9	Unknown	more

V0805	Aux Tank Type	8	Not applicable (not equipped)	more
V0806	Aux Tank Location	888	Not applicable (not equipped)	more
V0807	Aux Filler Cap Location	888	Not applicable (not equipped)	more
V0808	Aux Tank Material	8	Not applicable	more

Case Vehicle Fuel Leakage

[Back to Top](#)

Variable Number	Variable Name	Code Value	Code Description	Other Options
V0901	Fuel Leakage From Crash	0	No	more

Case Vehicle Fire

[Back to Top](#)

Variable Number	Variable Name	Code Value	Code Description	Other Options
V1001	Fire In Or On Case Vehicle	0	No	more

Case Vehicle Exterior

[Back to Top](#)

Variable Number	Variable Name	Code Value	Code Description	Other Options
V1101	Hood Latch Released	0	No	more
V1102	Hood Latch Damaged	1	Yes	more
V1103	Hood Latch Jammed	1	Yes	more
V1104	Left Hood Hinge Damaged	0	No	more
V1105	Left Hood Hinge Separated	8	Not applicable	more
V1106	Right Hood Hinge Damaged	1	Yes	more
V1107	Right Hood Hinge Separated	0	No	more
V1108	Hood Remained On Vehicle	1	Yes	more
V1109	Rear Hood Edge Elevated	1	Yes	more
V1110	Edge Contacted Windshield	0	No	more
V1111	Edge Penetrated Windshield	8	Not applicable	more
V1112	Hood Latch Location	1	Front of Vehicle	more
V1113	Eng/transmissn Mount Separated	0	No	more
V1114	Steering Column Flex Couplng	9	Unknown if equipped	more
V1115	Steering Column Coupling Dam	9	Unknown	more

V1116	Steering Column Coupling Separated	9	Unknown	more
V1117	Eng Comp Telescopng Unit	88	Not currently collected	more
V1118	Compartment Unit's Original/telescoped Length Difference	888	Not currently collected	more
V1119	Left Side Body Mount Separated	8	Not applicable (unitized)	more
V1120	Upper Left A-pillar Sep	0	No	more
V1121	Lower Left A-pillar Sep	0	No	more
V1122	Upper Left B-pillar Sep	0	No	more
V1123	Lower Left B-pillar Sep	0	No	more
V1124	Upper Left C-pillar Sep	0	No	more
V1125	Lower Left C-pillar Sep	0	No	more
V1126	Upper Left D-pillar Sep	0	No	more
V1127	Lower Left D-pillar Sep	0	No	more
V1128	Left Front Door Opening Cause	00	Door did not open	more
V1129	Left Rear Door Opening Cause	00	Door did not open	more
V1130	Left Front Door Jammed Closed	0	No	more
V1131	Left Rear Door Jammed Closed	0	No	more
V1132	Van Left Rear Door Type	8	Not applicable (not a van)	more
V1133	Left Front Glazing Availability	2	Closed	more
V1134	Left Rear Glazing Availability	2	Closed	more
V1135	Lr2 Glazing Availability	1	Fixed	more
V1136	Left Front Glazing Damage	0	No damage	more
V1137	Left Rear Glazing Damage	0	No damage	more
V1138	Lr2 Glazing Damage	0	No damage	more
V1139	Rear Door Type	2	One-way tailgate	more
V1140	Rear Door Opening Cause	0	Door did not open	more
V1141	Rear Door Jammed Closed	0	No	more
V1142	Rear Glazng Availability	1	Fixed	more
V1143	Rear Glazing Damage	0	No damage	more
V1144	Luggage Partition Damaged	8	Not applicable	more
V1145	Spare Tire Status	8	Not collected	more

V1146	Trailer Hitch Type	3	Bumper and frame (but non-equalizing)	more
V1147	Trailer Type	0	No trailer	more
V1148	Rght Side Body Mount Separated	8	Not applicable (unitized)	more
V1149	Upper Right A-pillar Separated	0	No	more
V1150	Lower Right A-pillar Separated	0	No	more
V1151	Upper Right B-pillar Separated	0	No	more
V1152	Lower Right B-pillar Separated	0	No	more
V1153	Upper Right C-pillar Separated	0	No	more
V1154	Lower Right C-pillar Separated	0	No	more
V1155	Upper Right D-pillar Separated	0	No	more
V1156	Lower Right D-pillar Separated	0	No	more
V1157	Right Front Door Opening Cause	00	Door did not open	more
V1158	Right Rear Door Opening Cause	00	Door did not open	more
V1159	Right Front Door Jammed Closed	0	No	more
V1160	Right Rear Door Jammed Closed	0	No	more
V1161	Van Right-rear Door Type	8	Not applicable (not a van)	more
V1162	Right Front Glazing Availability	2	Closed	more
V1163	Right Rear Glazing Availability	2	Closed	more
V1164	Rr2 Glazing Availability	1	Fixed	more
V1165	Right Front Glazing Damage	0	No damage	more
V1166	Right Rear Glazing Damage	0	No damage	more
V1167	Rr2 Glazing Damage	0	No damage	more
V1168	Windshield Cracked	1	Yes	more
V1169	Windshield Broken	0	No Click for Windshield Damage figure	more
V1170	Occupant Cracked/Broke Wndshld	0	No	more

V1171	Bond Separation Extent	0	None	more
V1172	Windshield Code	97	Click for Windshield Mark figure	more
V1173	Did Sun Roof/T-Roof Open	8	Not Applicable	more

Case Vehicle Steering Column/Rim

[Back to Top](#)

Variable Number	Variable Name	Code Value	Code Description	Other Options
V1201	Steering Wheel Rim Damage	0	None	more
V1202	Number of Steering Wheel Spokes	4	4 spokes	more
V1203	Steering Wheel Spoke Damage	0	None	more
V1204	Steering Wheel Hub Damage	0	None	more
V1205	Steering Wheel Location of Rim Damage	0	No damage	more
V1206	Aftermarket Add-on Device	0	None	more
V1207	Column Tilt Feature	3	Middle	more
V1208	Column Swing-away Feature	0	Not equipped	more
V1209	Column Telescoping Feature	0	Not equipped	more
V1210	Wheel Energy Absorb Device	8	Not currently collected	more
V1211	Wheel EA Device's original/damage Dimension Difference	888	Not collected	more
V1212	Column Energy Absorb Device	88	Not collected	more
V1213	Col EA Device's Orig/compressed (or Extruded) Length Diff	888	Not collected	more
V1214	Shear Capsule Separation	888	Not collected	more
V1215	Column Vertical Rotation	0	No apparent rotation	more
V1216	Column Lateral Rotation	0	No apparent rotation	more

Case Vehicle Intrusion

[Back to Top](#)

Variable Number	Variable Name	Code Value	Code Description	Other Options
V1301	Was Occupant Compartment Intruded	0	No Click for Intrusion Worksheet figure Click for Intrusion figure	more

V1302	Was Intrusn Catastrophic	8	Not applicable	more
V1303	Intrusion Number #1	99	Unknown or data not collected	more
V1304	Occupant Space Number(1)	99	Unknown or data not collected	more
V1305	Intrud Component/obj (1)	99	Unknown or data not collected	more
V1306	Associate Event Numb (1)	9	Unknown or data not collected	more
V1307	Maximum Intrusion X Axis	99	Unknown or data not collected	more
V1308	Maximum Intrusion Y Axis	99	Unknown or data not collected	more
V1309	Maximum Intrusion Z Axis	99	Unknown or data not collected	more
V1310	Occupant Number #1 (1)	99	Unknown or data not collected	more
V1311	Injury Number #1 (1)	99	Contact, injury unknown or data not collected	more
V1312	Occupant Number #2 (1)	99	Unknown or data not collected	more
V1313	Injury Number #2 (1)	99	Contact, injury unknown or data not collected	more
V1314	Intrusion Number #2	99	Unknown or data not collected	more
V1315	Occupant Space Number(2)	99	Unknown or data not collected	more
V1316	Intrud Component/obj (2)	99	Unknown or data not collected	more
V1317	Associate Event Numb (2)	9	Unknown or data not collected	more
V1318	Maximum Intrusion X Axis	99	Unknown or data not collected	more
V1319	Maximum Intrusion Y Axis	99	Unknown or data not collected	more
V1320	Maximum Intrusion Z Axis	99	Unknown or data not collected	more
V1321	Occupant Number #1 (2)	99	Unknown or data not collected	more
V1322	Injury Number #1 (2)	99	Contact, injury unknown or data not collected	more
V1323	Occupant Number #2 (2)	99	Unknown or data not collected	more
V1324	Injury Number #2 (2)	99	Contact, injury unknown or data not collected	more
V1325	Intrusion Number #3	99	Unknown or data not collected	more
V1326	Occupant Space Number(3)	99	Unknown or data not collected	more
V1327	Intrud Compnent/obj (3)	99	Unknown or data not collected	more
V1328	Associate Event Numb (3)	9	Unknown or data not collected	more
V1329	Maximum Intrusion X Axis	99	Unknown or data not collected	more
V1330	Maximum Intrusion Y Axis	99	Unknown or data not collected	more
V1331	Maximum Intrusion Z Axis	99	Unknown or data not collected	more
V1332	Occupant Number #1 (3)	99	Unknown or data not collected	more
V1333	Injury Number #1 (3)	99	Contact, injury unknown or data not collected	more
V1334	Occupant Number #2 (3)	99	Unknown or data not collected	more
V1335	Injury Number #2 (3)	99	Contact, injury unknown or data not	more

			collected	
V1336	Intrusion Number #4	99	Unknown or data not collected	more
V1337	Occupant Space Number(4)	99	Unknown or data not collected	more
V1338	Intrud Component/obj (4)	99	Unknown or data not collected	more
V1339	Associate Event Numb (4)	9	Unknown or data not collected	more
V1340	Maximum Intrusion X Axis	99	Unknown or data not collected	more
V1341	Maximum Intrusion Y Axis	99	Unknown or data not collected	more
V1342	Maximum Intrusion Z Axis	99	Unknown or data not collected	more
V1343	Occupant Number #1 (4)	99	Unknown or data not collected	more
V1344	Injury Number #1 (4)	99	Contact, injury unknown or data not collected	more
V1345	Occupant Number #2 (4)	99	Unknown or data not collected	more
V1346	Injury Number #2 (4)	99	Contact, injury unknown or data not collected	more
V1347	Intrusion Number #5	99	Unknown or data not collected	more
V1348	Occupant Space Number(5)	99	Unknown or data not collected	more
V1349	Intrud Component/obj (5)	99	Unknown or data not collected	more
V1350	Associate Event Numb (5)	9	Unknown or data not collected	more
V1351	Maximum Intrusion X Axis	99	Unknown or data not collected	more
V1352	Maximum Intrusion Y Axis	99	Unknown or data not collected	more
V1353	Maximum Intrusion Z Axis	99	Unknown or data not collected	more
V1354	Occupant Number #1 (5)	99	Unknown or data not collected	more
V1355	Injury Number #1 (5)	99	Contact, injury unknown or data not collected	more
V1356	Occupant Number #2 (5)	99	Unknown or data not collected	more
V1357	Injury Number #2 (5)	99	Contact, injury unknown or data not collected	more
V1358	Intrusion Number #6	99	Unknown or data not collected	more
V1359	Occupant Space Number(6)	99	Unknown or data not collected	more
V1360	Intrud Component/obj (6)	99	Unknown or data not collected	more
V1361	Associate Event Numb (6)	9	Unknown or data not collected	more
V1362	Maximum Intrusion X Axis	99	Unknown or data not collected	more
V1363	Maximum Intrusion Y Axis	99	Unknown or data not collected	more
V1364	Maximum Intrusion Z Axis	99	Unknown or data not collected	more
V1365	Occupant Number #1 (6)	99	Unknown or data not collected	more
V1366	Injury Number #1 (6)	99	Contact, injury unknown or data not collected	more
V1367	Occupant Number #2 (6)	99	Unknown or data not collected	more
V1368	Injury Number #2 (6)	99	Contact, injury unknown or data not	more

			collected	
V1369	Intrusion Number #7	99	Unknown or data not collected	more
V1370	Occupant Space Number(7)	99	Unknown or data not collected	more
V1371	Intrud Component/obj (7)	99	Unknown or data not collected	more
V1372	Associate Event Numb (7)	9	Unknown or data not collected	more
V1373	Maximum Intrusion X Axis	99	Unknown or data not collected	more
V1374	Maximum Intrusion Y Axis	99	Unknown or data not collected	more
V1375	Maximum Intrusion Z Axis	99	Unknown or data not collected	more
V1376	Occupant Number #1 (7)	99	Unknown or data not collected	more
V1377	Injury Number #1 (7)	99	Contact, injury unknown or data not collected	more
V1378	Occupant Number #2 (7)	99	Unknown or data not collected	more
V1379	Injury Number #2 (7)	99	Contact, injury unknown or data not collected	more
V1380	Intrusion Number #8	99	Unknown or data not collected	more
V1381	Occupant Space Number(8)	99	Unknown or data not collected	more
V1382	Intrud Component/obj (8)	99	Unknown or data not collected	more
V1383	Associate Event Numb (8)	9	Unknown or data not collected	more
V1384	Maximum Intrusion X Axis	99	Unknown or data not collected	more
V1385	Maximum Intrusion Y Axis	99	Unknown or data not collected	more
V1386	Maximum Intrusion Z Axis	99	Unknown or data not collected	more
V1387	Occupant Number #1 (8)	99	Unknown or data not collected	more
V1388	Injury Number #1 (8)	99	Contact, injury unknown or data not collected	more
V1389	Occupant Number #2 (8)	99	Unknown or data not collected	more
V1390	Injury Number #2 (8)	99	Contact, injury unknown or data not collected	more
V1391	Intrusion Number #9	99	Unknown or data not collected	more
V1392	Occupant Space Number(9)	99	Unknown or data not collected	more
V1393	Intrud Component/obj (9)	99	Unknown or data not collected	more
V1394	Associate Event Numb (9)	9	Unknown or data not collected	more
V1395	Maximum Intrusion X Axis	99	Unknown or data not collected	more
V1396	Maximum Intrusion Y Axis	99	Unknown or data not collected	more
V1397	Maximum Intrusion Z Axis	99	Unknown or data not collected	more
V1398	Occupant Number #1 (9)	99	Unknown or data not collected	more
V1399	Injury Number #1 (9)	99	Contact, injury unknown or data not collected	more
V1400	Occupant Number #2 (9)	99	Unknown or data not collected	more
V1401	Injury Number #2 (9)	99	Contact, injury unknown or data not	more

			collected	
V1402	Intrusion Number #10	99	Unknown or data not collected	more
V1403	Occupant Space Number (10)	99	Unknown or data not collected	more
V1404	Intrud Component/obj(10)	99	Unknown or data not collected	more
V1405	Associate Event Numb(10)	9	Unknown or data not collected	more
V1406	Maximum Intrusion X Axis	99	Unknown or data not collected	more
V1407	Maximum Intrusion Y Axis	99	Unknown or data not collected	more
V1408	Maximum Intrusion Z Axis	99	Unknown or data not collected	more
V1409	Occupant Number #1 (10)	99	Unknown or data not collected	more
V1410	Injury Number #1 (10)	99	Contact, injury unknown or data not collected	more
V1411	Occupant Number #2 (10)	99	Unknown or data not collected	more
V1412	Injury Number #2 (10)	99	Contact, injury unknown or data not collected	more
V1413	Intrusion Number (a)	88	Not Applicable	more
V1414	Cause Of Intrusion (a)	8	Not applicable	more
V1415	Intrusion Number (b)	88	Not Applicable	more
V1416	Cause Of Intrusion (b)	8	Not applicable	more
V1417	Intrusion Number (c)	88	Not Applicable	more
V1418	Cause Of Intrusion (c)	8	Not applicable	more
V1419	Intrusion Number (a)	88	Not Applicable	more
V1420	Damaged Component 1 (a)	8	Not Applicable	more
V1421	Damaged Component 2 (a)	8	Not Applicable	more
V1422	Intrusion Number (b)	88	Not Applicable	more
V1423	Damaged Component 1 (b)	8	Not Applicable	more
V1424	Damaged Component 2 (b)	8	Not Applicable	more
V1425	Intrusion Number (c)	88	Not Applicable	more
V1426	Damaged Component 1 (c)	8	Not Applicable	more
V1427	Damaged Component 2 (c)	8	Not Applicable	more
V1428	Intrusion Number (d)	88	Not Applicable	more
V1429	Damaged Component 1 (d)	8	Not Applicable	more
V1430	Damaged Component 2 (d)	8	Not Applicable	more

Case Vehicle Airbag(s)

[Back to Top](#)

Variable Number	Variable Name	Code Value	Code Description	Other Options
V1501	Driver Airbag Equipped	1	Yes Click for Driver Airbag figure	more

V1502	Right Front Airbag Equip	1	Yes Click for Passenger Airbag figure	more
V1503	Left Rear Airbag Equipped	0	No	more
V1504	Right Rear Airbag Equipped	0	No	more
V1505	Driver Airbag Deployed	1	Yes	more
V1506	Rght Front Airbag Deploy	1	Yes	more
V1507	Left Rear Airbag Deploy	8	Not applicable (no airbag)	more
V1508	Rught Rear Airbag Deploy	8	Not applicable (no airbag)	more
V1509	Driver On/off Switch	0	Not equipped (no switch)	more
V1510	Rght Front On/off Switch	0	Not equipped (no switch)	more
V1511	Left Rear On/off Switch	8	Not applicable (no airbag)	more
V1512	Right Rear On/off Switch	8	Not applicable (no airbag)	more
V1513	Driver Airbag Location	1	Steering wheel	more
V1514	Right Front Airbag Location	3	Mid instrument panel	more
V1515	Left Rear Airbag Location	0	No airbag	more
V1516	Right Rear Airbag Location	0	No airbag	more
V1517	Driver Airbag Condition	0	No damage	more
V1518	Right Front Airbag Condition	0	No damage	more
V1519	Left Rear Airbag Condition	8	Not applicable (not equipped / not deployed)	more
V1520	Right Rear Airbag Condition	8	Not applicable (not equipped / not deployed)	more
V1521	Driver Airbag Tether	1	Yes	more
V1522	Right Front Airbag Tether	0	No	more
V1523	Left Rear Airbag Tether	8	Not applicable	more
V1524	Right Rear Airbag Tether	8	Not applicable	more
V1525	Driver Marked By Contact	0	No	more
V1526	Right Front Marked By Contact	0	No	more
V1527	Left Rear Marked By Contact	8	Not applicable (no airbag / not deployed)	more
V1528	Right Rear Marked By Contact	8	Not applicable (no airbag / not deployed)	more
V1529	Driver Module Type	1	H-pattern flaps	more
V1530	Right Front Module Type	3	U-pattern flaps	more
V1531	Left Rear Module Type	0	No airbag present	more
V1532	Right Rear Module Type	0	No airbag present	more
V1533	Driver Module Cover Dam.	1	Flaps not damaged / marked	more
V1534	Right Front Module Cover	1	Flaps not damaged / marked	more

	Dam.			
V1535	Left Rear Module Cover Dam.	0	No airbag	more
V1536	Right Rear Module Cover Dam.	0	No airbag	more
V1537	Driver Airbag Type	1	Original equipment	more
V1538	Right Front Airbag Type	1	Original equipment	more
V1539	Left Rear Airbag Type	0	No airbag	more
V1540	Right Rear Airbag Type	0	No airbag	more
V1541	Driver Airbag Vents	2	Vents present	more
V1542	Right Front Airbag Vents	2	Vents present	more
V1543	Left Rear Airbag Vents	0	No airbag	more
V1544	Right Rear Airbag Vents	0	No airbag	more
V1545	Driver Knee Bolster Equipped	0	No	more
V1546	Right Front Knee Bolster Equipped	0	No	more
V1547	Left Rear Knee Bolster Equipped	0	No	more
V1548	Right Rear Knee Bolster Equipped	0	No	more
V1549	Driver Knee Bolster Deploy	8	Not applicable (no airbag)	more
V1550	Right Front Knee Bolster Deploy	8	Not applicable (no airbag)	more
V1551	Left Rear Knee Bolster Deploy	8	Not applicable (no airbag)	more
V1552	Right Rear Knee Bolster Deploy	8	Not applicable (no airbag)	more
V1553	Left Front Number of Tethers	2	Tethers	more
V1554	Left Front Number of Vents	2	Vents	more
V1555	Right Front Number of Tethers	0	None	more
V1556	Right Front Number of Vents	2	Vents	more
V1557	Left Rear Number of Tethers	8	Not applicable (no airbag)	more
V1558	Left Rear Number of Vents	8	Not applicable (no airbag)	more
V1559	Right Rear Number of Tethers	8	Not applicable (no airbag)	more
V1560	Right Rear Number of Vents	8	Not applicable (no airbag)	more

Variable Number	Variable Name	Code Value	Code Description	Other Options
V1601	Left Front Door Damaged	0	No	more
V1602	Right Front Door Damaged	0	No	more
V1603	Left Front Hardware Damaged	0	No	more
V1604	Right Front Hardware Damaged	0	No	more
V1605	Left Front Armrest Damaged	0	No	more
V1606	Right Front Armrest Damaged	0	No	more
V1607	Left Front Glass Damaged	0	No	more
V1608	Right Front Glass Damaged	0	No	more
V1609	Left Rear Door Area Damaged	0	No	more
V1610	Right Rear Door Area Damaged	0	No	more
V1611	Left Rear Hardware Damaged	0	No	more
V1612	Right Rear Hardware Damaged	0	No	more
V1613	Left Rear Armrest Damaged	0	No	more
V1614	Right Rear Armrest Damaged	0	No	more
V1615	Left Rear Glass Damaged	0	No	more
V1616	Right Rear Glass Damaged	0	No	more
V1617	Left Roof Side Rail Damaged	0	No	more
V1618	Right Roof Side Rail Damaged	0	No	more
V1619	Left B-pillar Damaged	0	No	more
V1620	Right B-pillar Damaged	0	No	more
V1621	Left C-pillar Damaged	0	No	more
V1622	Right C-pillar Damaged	0	No	more
V1623	Left D-pillar Damaged	0	No	more
V1624	Right D-pillar Damaged	0	No	more
V1625	Left Headlining Damaged	0	No	more
V1626	Right Headlining Damaged	0	No	more
V1627	Left Roof Structure Damaged	0	No	more

V1628	Right Roof Structure Damaged	0	No	more
V1629	Left T/sun Roof Damaged	8	Not applicable	more
V1630	Right T/sun Roof Damaged	8	Not applicable	more
V1631	Other Left Side Item Damagd	8	Not applicable	more
V1632	Other Right Side Item Damagd	8	Not applicable	more
V1633	Foot Controls Damaged	0	No	more
V1634	Ignition Key Damaged	0	No	more
V1635	Rear View Mirror Damaged	0	No	more
V1636	Sunvisor/fitting Damaged	0	No	more
V1637	Windshld Molding Damaged	0	No	more
V1638	Left A-pillar Damaged	0	No	more
V1639	Right A-pillar Damaged	0	No	more
V1640	Console Damaged	0	No	more
V1641	Transmissn Lever Damaged	0	No	more
V1642	Horn/spoke Shroud Damagd	0	No	more
V1643	Upper Panel Damaged	0	No	more
V1644	Mid Panel Damaged	0	No	more
V1645	Lower Panel Damaged	3	No, occupant contact	more
V1646	Ashtray Damaged	0	No	more
V1647	Control Knob/lever Damaged	0	No	more
V1648	Glove Compart Area Damaged	0	No	more
V1649	Instruments Damaged	0	No	more
V1650	Park Brake Release Damaged	0	No	more
V1651	Park Brake Pedal Damaged	0	No	more
V1652	A/c Or Upper Vent Damagd	0	No	more
V1653	Heater Or A/c Duct Damaged	0	No	more
V1654	Radio Damaged	0	No	more
V1655	Other Front Item Damaged	8	Not applicable	more
V1656	Rear Backlight Damaged	0	No	more
V1657	Backlight Header Damaged	0	No	more
V1658	Vertical Console Damaged	0	No	more
V1659	Roof Console Damaged	0	No	more

Case Vehicle Seats

[Back to Top](#)

Variable Number	Variable Name	Code Value	Code Description	Other Options
V1701	Driver Front Seat Type	05	Bucket	more
V1702	Passenger Front Seat Type	05	Bucket	more
V1703	Driver Seat Mount Type	1	Standard	more
V1704	Passenger Seat Mount Type	1	Standard	more
V1705	Driver Swivel Mech Equipped	0	No	more
V1706	Passenger Swivel Mech Equipped	0	No	more
V1707	Driver Seat Original Equipment	1	Yes	more
V1708	Passenger Seat Original Equipment	1	Yes	more
V1709	Driver Seat/rear Oc Contct	0	No	more
V1710	Passenger Seat/rear Oc Contct	0	No	more
V1711	Driver Seat Damage	0	None	more
V1712	Passenger Seat Damage	0	None	more
V1713	Cntr Frnt Armrest Damagd	0	No	more
V1714	Driver Seat-back Rotation	0	None apparent	more
V1715	Passenger Seat-back Rotation	0	None apparent	more
V1716	Driver Seat-back Type	3	Reclining	more
V1717	Passenger Seat-back Type	3	Reclining	more
V1718	Driver Seat-back Lock Type	1	Manual	more
V1719	Passenger Seat-back Lock Type	1	Manual	more
V1720	Driver Seat-back Lock Held	1	Yes	more
V1721	Passenger Seat-back Lock Held	1	Yes	more
V1722	Driver Recliner Mech Held	1	Yes	more
V1723	Passenger Recliner Mech Held.	1	Yes	more
V1724	Driver Head Restraint Type	1	Adjustable	more
V1725	Passenger Head Restraint Type	1	Adjustable	more
V1726	Driver Head Rest Removed	0	No	more

V1727	Passenger Head Rest Removed	0	No	more
V1728	Driver Head Rest Adjustmnt	1	Up	more
V1729	Passenger Head Rest Adjustmnt	1	Up	more
V1730	Driver Head Rest Damage	0	None	more
V1731	Passenger Head Rest Damage	0	None	more
V1732	Driver Rear Impact Counter	0	None	more
V1733	Passenger Rear Impact Counter	0	None	more
V1734	Driver Seat Adjustmnt Type	2	Power	more
V1735	Passenger Seat Adjustmnt Type	2	Power	more
V1736	Driver Seat Adjust Provisn	3	6-way	more
V1737	Passenger Seat Adjust Provisn	3	6-way	more
V1738	Driver Seat Adjuster Dam	0	None	more
V1739	Passenger Seat Adjuster Dam	0	None	more
V1740	Driver Seat Adjuster Sep	8	Not applicable	more
V1741	Passenger Seat Adjuster Sep	8	Not applicable	more
V1742	Driver Seat Pre-crash Pos	1	Forward	more
V1743	Passenger Seat Pre-crash Pos	1	Forward	more
V1744	Left Rear Seat Type	2	Folding	more
V1745	Rght Rear Seat Type	2	Folding	more
V1746	Left Rear Seat Damage	0	None	more
V1747	Rght Rear Seat Damage	0	None	more
V1748	Cntr Rear Armrest Damagd	8	Not applicable	more
V1749	Left Rear Seat-back Left Lock Equipped	1	Yes	more
V1750	Right Rear Seat-back Left Lock Equipped	0	No	more
V1751	Left Rear Seat-back Left Lock Held	1	Yes	more
V1752	Right Rear Seat-back Left Lock Held	8	Not applicable	more
V1753	Left Rear Seat-back Right Lock Equipped	0	No	more
V1754	Right Rear Seat-back Right Lock Equipped	1	Yes	more

V1755	Left Rear Seat-back Right Lock Held	8	Not applicable	more
V1756	Right Rear Seat-back Right Lock Held	1	Yes	more
V1757	Left 3rd Seat Equipped	8	Not applicable	more
V1758	Right 3rd Seat Equipped	8	Not applicable	more
V1759	Left 3rd Row Type Seat	0	None	more
V1760	Right 3rd Row Type Seat	0	None	more
V1761	Left 3rd Seat Damage	8	Not applicable	more
V1762	Right 3rd Seat Damage	8	Not applicable	more
V1763	Left 3rd Seat Cushion Dam	8	Not applicable	more
V1764	Right 3rd Seat Cushion Dam	8	Not applicable	more
V1765	Left 3rd Seat L/c Lock Equipped	8	Not applicable	more
V1766	Right 3rd Seat L/c Lock Equipped	8	Not applicable	more
V1767	Left 3rd Seat L/c Lock Held	8	Not applicable	more
V1768	Right 3rd Seat L/c Lock Held	8	Not applicable	more
V1769	Left 3rd Seat Right Lock Equipped	8	Not applicable	more
V1770	Right 3rd Seat Right Lock Equipped	8	Not applicable	more
V1771	Left 3rd Seat Right Lock Held	8	Not applicable	more
V1772	Right 3rd Seat Right Lock Held	8	Not applicable	more
V1773	Rear Head Restraints	1	Equipped	more

Case Vehicle Side Airbag(s)

[Back to Top](#)

Variable Number	Variable Name	Code Value	Code Description	Other Options
V1801	Side Airbag Equipped	1	Yes, equipped	more
V1802	Left Front Seatback Mount Deploy	2	Not deployed	more
V1803	Right Front Seatback Mount Deploy	2	Not deployed	more
V1804	Left Rear Seatback Mount Deploy	0	Not equipped	more
V1805	Right Rear Seatback Mount	0	Not equipped	more

	Deploy			
V1806	Left Front Seatback Module Type	3	Not deployed	more
V1807	Right Front Seatback Module Type	3	Not deployed	more
V1808	Left Rear Seatback Module Type	0	Not equipped	more
V1809	Right Rear Seatback Module Type	0	Not equipped	more
V1810	Left Front Seatback Airbag Type	5	Not deployed	more
V1811	Right Front Seatback Airbag Type	5	Not deployed	more
V1812	Left Rear Seatback Airbag Type	0	Not equipped	more
V1813	Right Rear Seatback Airbag Type	0	Not equipped	more
V1814	Left Front Seatback Airbag Cond.	8	Not deployed	more
V1815	Right Front Seatback Airbag Cond.	8	Not deployed	more
V1816	Left Rear Seatback Airbag Cond.	0	Not equipped	more
V1817	Right Rear Seatback Airbag Cond.	0	Not equipped	more
V1818	Left Front Door-mounted Deploy	0	Not equipped	more
V1819	Right Front Door-mounted Deploy	0	Not equipped	more
V1820	Left Rear Door-mounted Deploy	0	Not equipped	more
V1821	Right Rear Door-mounted Deploy	0	Not equipped	more
V1822	Left Front Door Module Type	0	Not equipped	more
V1823	Right Front Door Module Type	0	Not equipped	more
V1824	Left Rear Door Module Type	0	Not equipped	more
V1825	Right Rear Door Module Type	0	Not equipped	more
V1826	Left Front Door Airbag Type	0	Not equipped	more
V1827	Right Front Door Airbag Type	0	Not equipped	more

V1828	Left Rear Door Airbag Type	0	Not equipped	more
V1829	Right Rear Door Airbag Type	0	Not equipped	more
V1830	Left Front Door Airbag Condition	0	Not equipped	more
V1831	Right Front Door Airbag Condition	0	Not equipped	more
V1832	Left Rear Door Airbag Condition	0	Not equipped	more
V1833	Right Rear Door Airbag Condition	0	Not equipped	more
V1834	Left Front Roof Mounted Deploy	0	Not equipped	more
V1835	Right Front Roof Mounted Deploy	0	Not equipped	more
V1836	Left Rear Roof Mounted Deploy	0	Not equipped	more
V1837	Right Rear Roof Mounted Deploy	0	Not equipped	more
V1838	Left Front Roof Module Type	0	Not equipped	more
V1839	Right Front Roof Module Type	0	Not equipped	more
V1840	Left Rear Roof Module Type	0	Not equipped	more
V1841	Right Rear Roof Module Type	0	Not equipped	more
V1842	Left Front Roof Airbag Type	0	Not equipped	more
V1843	Right Front Roof Airbag Type	0	Not equipped	more
V1844	Left Rear Roof Airbag Type	0	Not equipped	more
V1845	Right Rear Roof Airbag Type	0	Not equipped	more
V1846	Left Front Roof Airbag Condition	0	Not equipped	more
V1847	Right Front Roof Airbag Condition	0	Not equipped	more
V1848	Left Rear Roof Airbag Condition	0	Not equipped	more
V1849	Right Rear Roof Airbag Condition	0	Not equipped	more

EDR -- Event Data Recorder

[Back to Top](#)

Variable	Variable Name	Code	Code Description	Other
----------	---------------	------	------------------	-------

Number		Value		Options
V1901	Case Vehicle EDR Equipped	1	Yes	more
V1902	Type Of File Recovered	1	Not downloaded	more
V1903	EDR Pre-crash Braking	1	Not downloaded	more
V1904	Event Data Recorder (EDR) Pre-impact Speed	92	Not downloaded	more
V1905	EDR Driver Belt Status	1	Not downloaded	more
V1906	EDR Right Front Belt Status	1	Not downloaded	more
V1907	Right Front Airbag Suppressed	1	Not downloaded	more
V1908	Sir Warning Lamp Status	1	Not downloaded	more
V1909	Time Between Near Deployment and Deployment (in Seconds)	6	Not downloaded	more
V1910	Time Between Algorithm Enable and Deployment (in ms)	000	Not equipped	more
V1911	Maximum Recorded Longitudinal Velocity Change (mph)	000	No time / not collected	more
V1912	Maximum Recorded Lateral Velocity Change (mph)	000	No time / not collected	more
V1913	More Than One Deploy?	1	Not downloaded	more

Side Airbags

did not deploy

Seatback Airbag

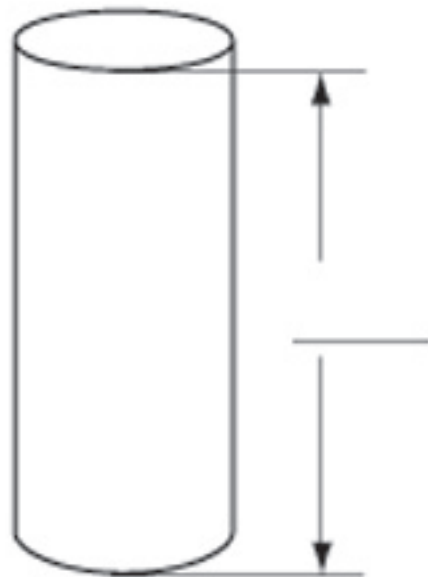

30

Diameter: _____

Vents: Y N
if yes, how many: _____

Tethers: Y N
if yes, how many: _____

module cover

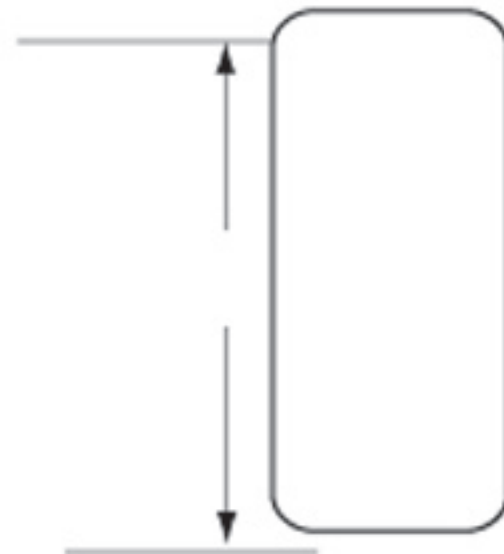

Passenger Airbag

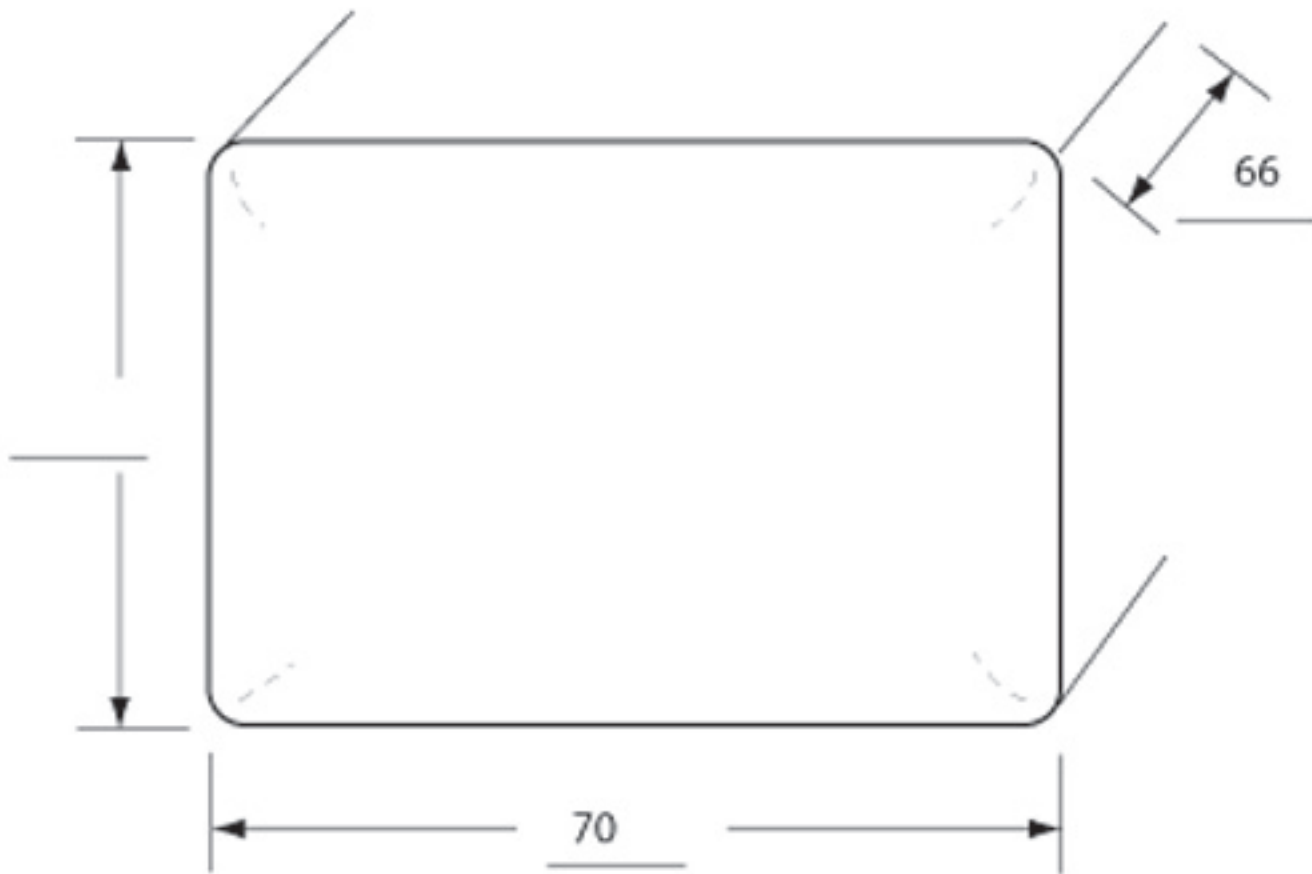

Vents: Y N
if yes, how many: 2

Tethers: Y N
if yes, how many: _____

vents at 10 and 2 o'clock

Single Door Passenger Airbag Doors



Driver Airbag

AIRBAG NUMBER ON DRIVER SIDE:

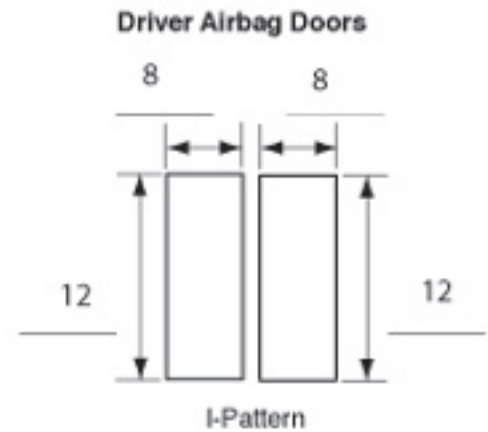
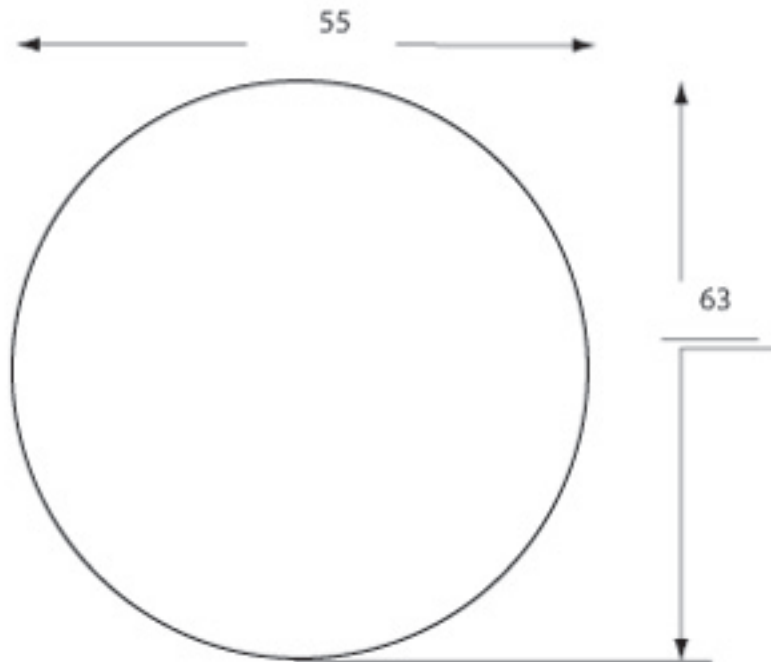

Vents: Y N
if yes, how many: 2

Tethers: Y N
if yes, how many: 2

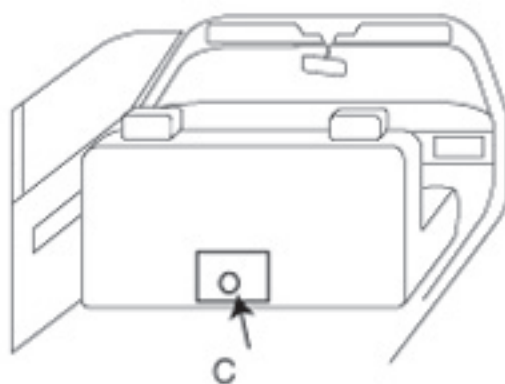
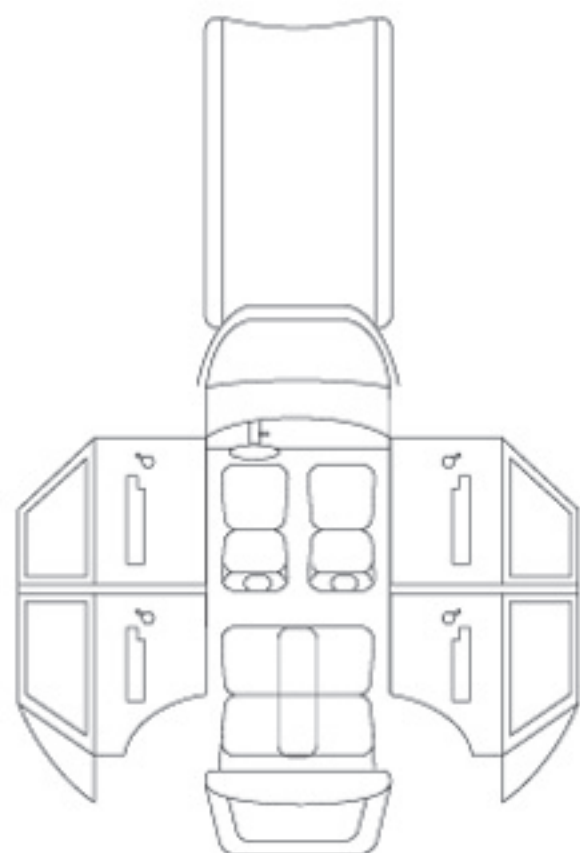

DR: Seat-Integrated belt, no evidence of use

CTR REAR: Evidence of regular use on latch

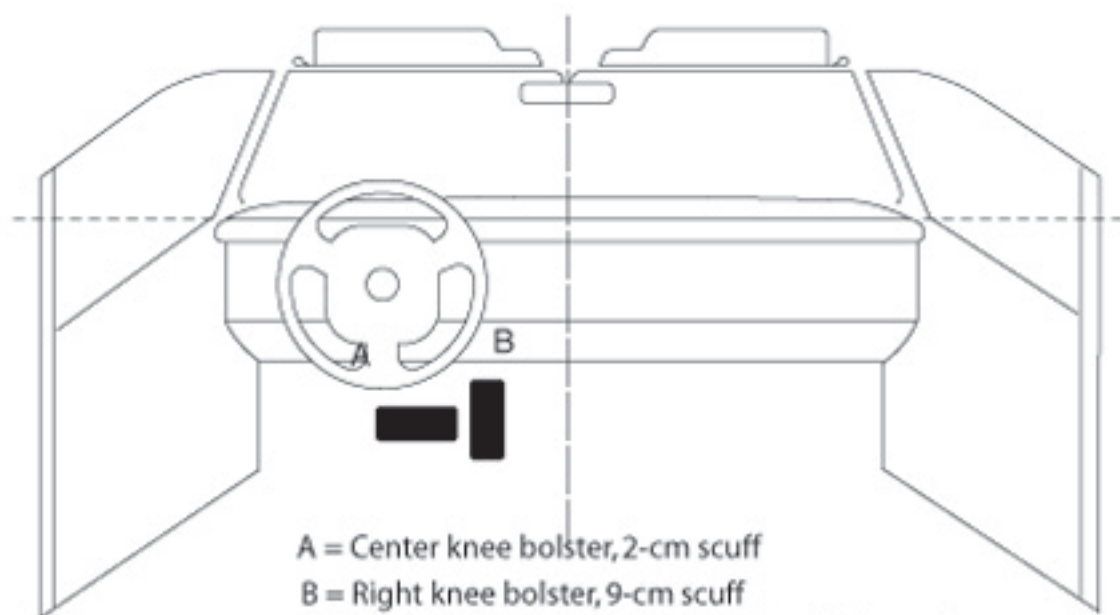

A = Center knee bolster, 2-cm scuff

B = Right knee bolster, 9-cm scuff

C = Center console, scuff on left side of lighter plug

1 = Definitely 2 = Probably 3 = Possible

INTRUSION IT-1

Location of Intrusion	Intruded Component	(All Measurements Are in Centimeters)			Dominant Crush Direction
		Comparison Value	Intruded Value	Intrusion	
none		-	=		
		-	=		
		-	=		
		-	=		
		-	=		
		-	=		
		-	=		
		-	=		
		-	=		
		-	=		
		-	=		
		-	=		
		-	=		
		-	=		

OCCUPANT CONTACT WORKSHEET

Contact	Interior Component Contacted	Occupant No. if Known	Body Region if Known	Supporting Physical Evidence	Confidence Level of Contact Point
A	Knee bolster	1	Knee	2-cm scuff to center	1
B	Knee bolster	1	Knee	9-cm scuff to right	1
C	Rear of center console	2	Feet	Scuff marks/dirt	2
D					
E					
F					
G					
H					

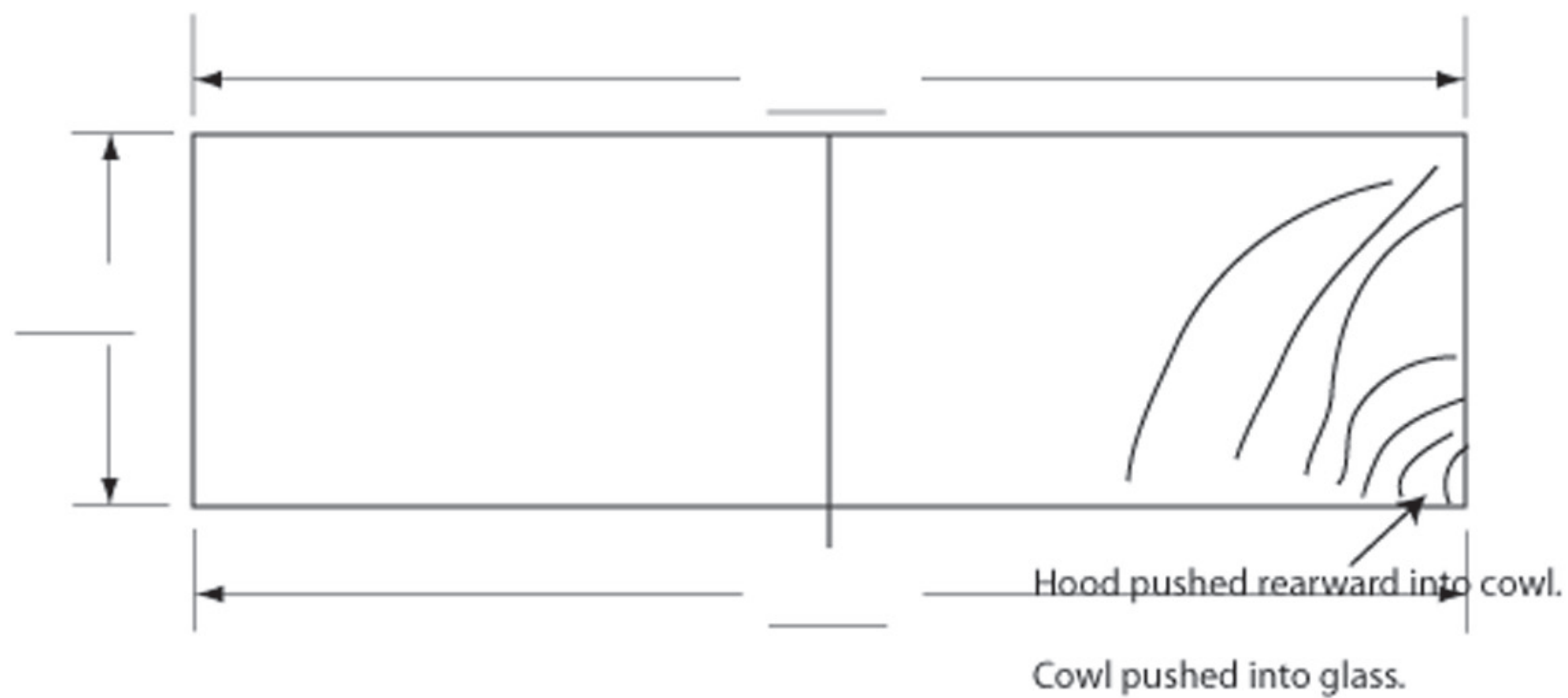

WINDSHIELD MARK ON CASE VEHICLE:



LAMINATED GS

DOT 376 AS1 M334

TRANS 70% MIN

AP TECHNOGLASS.

1.....

MEASUREMENTS IN CENTIMETERS

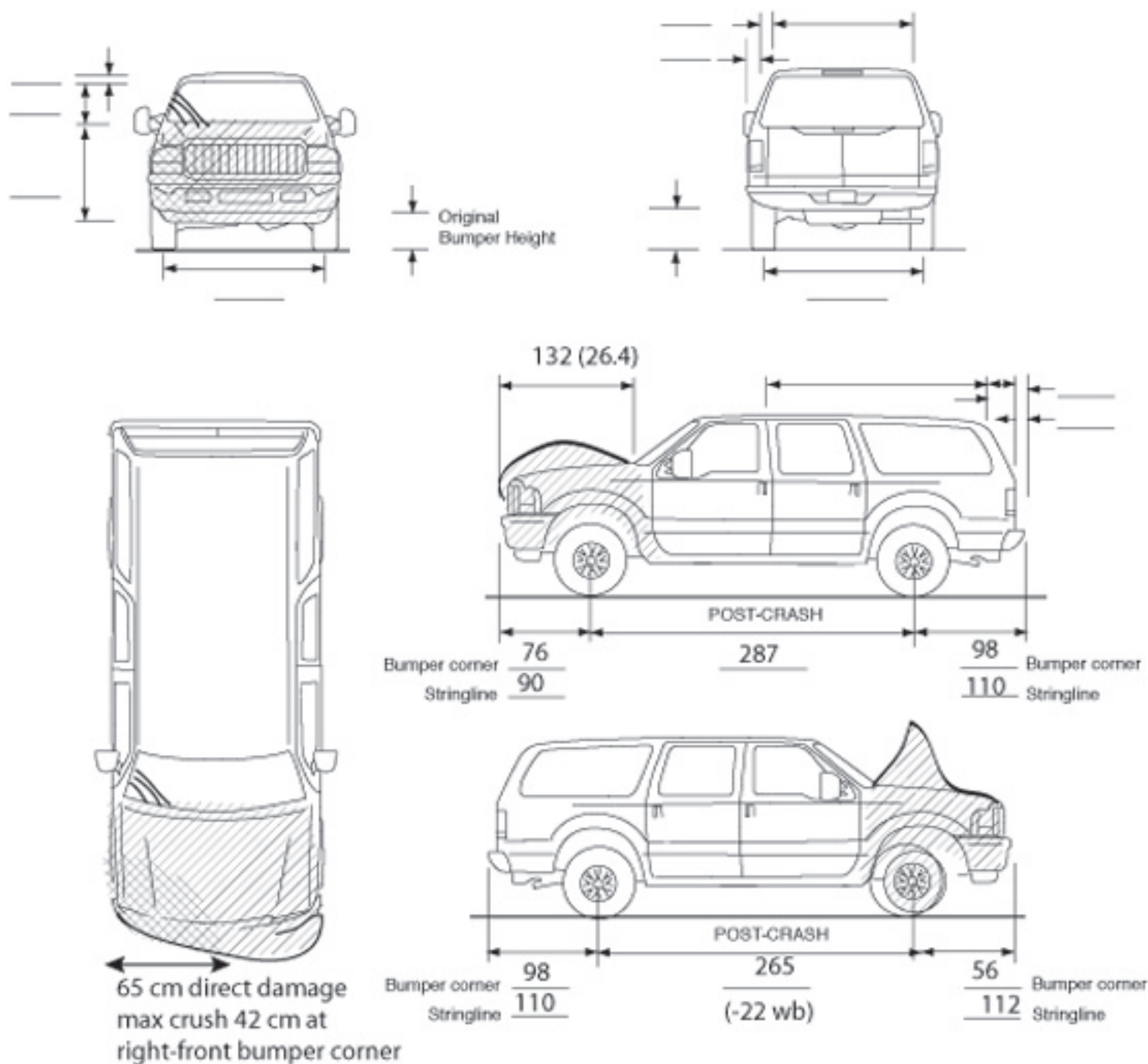

MEASUREMENTS IN CENTIMETERS

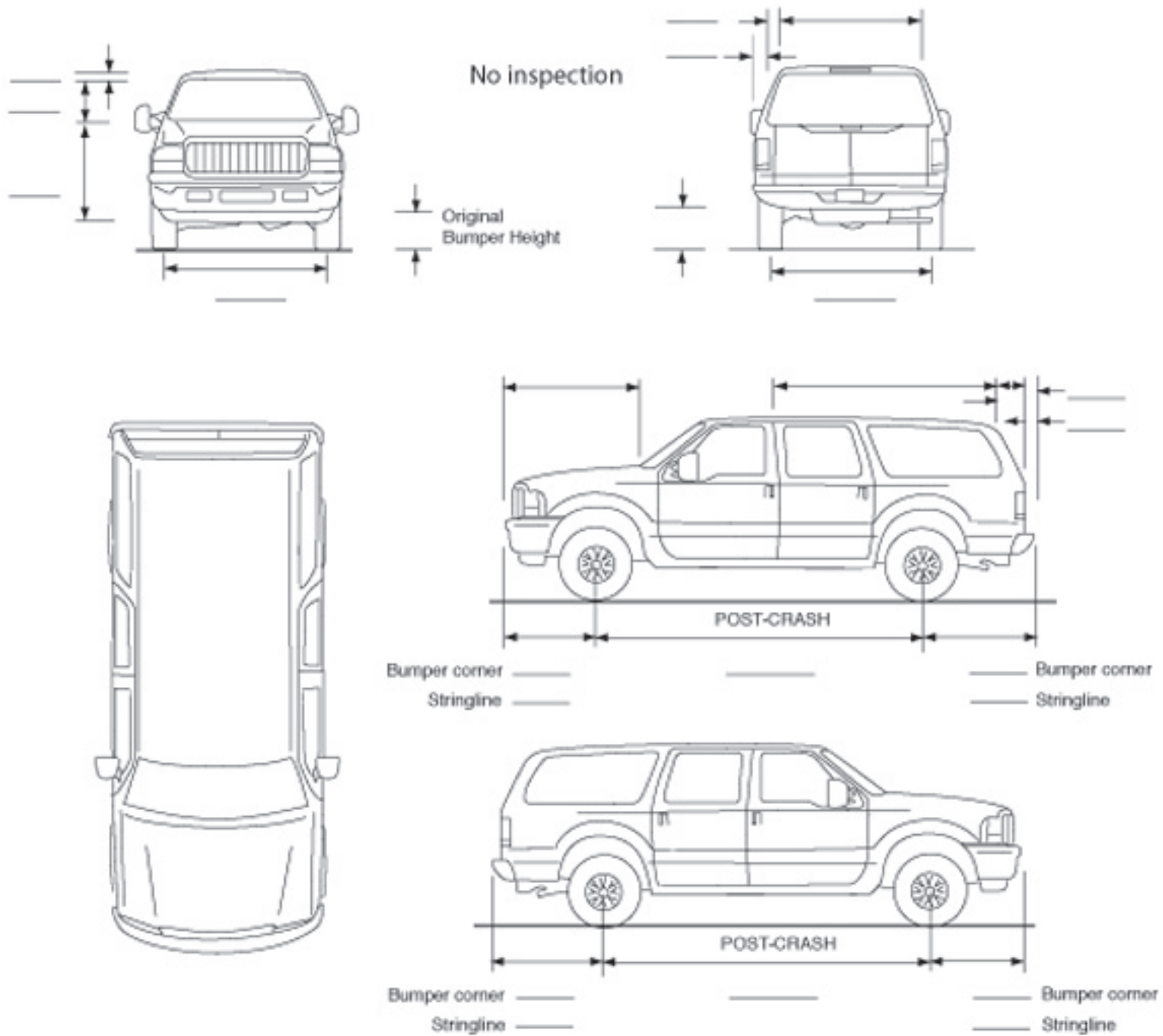

Side Airbags

did not deploy

Seatback Airbag

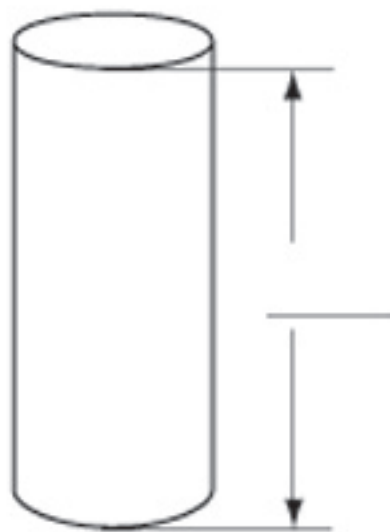

30

Diameter: _____

Vents: Y N
if yes, how many: _____

Tethers: Y N
if yes, how many: _____

module cover

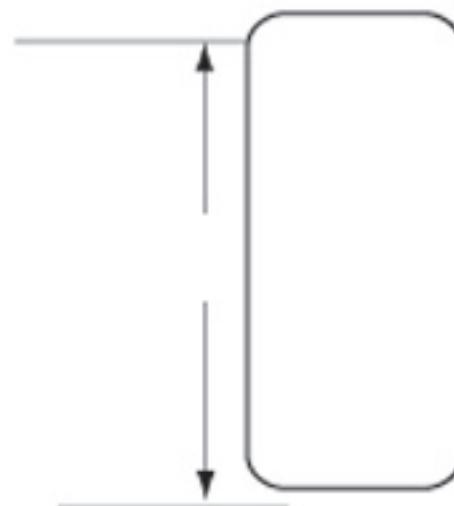



REAR
CENTER



SEAT BELT

RR







DR



DR



DR



PWR

SEEK













AIR BAG



































AIR BAG

AIR BAG

DR







Overdrive

























































40









YEAR
CENTER

