

## Case 450 : Narrative

Case Vehicle (A): 2000 Hyundai	Vehicle (B): 1998 Ford
Type: Accent GL, 4-door sedan	Type: Explorer Sport, 4x2, 2-door SUV
Driver: 59-year-old female	Driver: 38-year-old female
CDC: 01-FZEW-2	CDC: 12-FYEW-2

### SITUATION

1 It was daylight and cloudy and the road surface was wet and slippery as 2 case vehicle (A) was traveling west at an unknown speed in the westbound lane of a two-lane, east-west asphalt road. 3 Vehicle (B) was traveling east at an unknown speed in the eastbound lane of the same road. 4 As both vehicles approached a four-way intersection with a north-south road, the driver of case vehicle (A) thought vehicle (B) was going to stop and 5 began to make a left turn to travel south. The driver of vehicle (B) did not take any evasive action and the left-front corner of vehicle (B) struck and overrode the right front of case vehicle (A). Both vehicles were towed due to damage.

The Police Accident Report (PAR) indicates C-level injuries for the female driver of case vehicle (A), who was transported by ambulance to a hospital, where she was treated and released. The PAR indicates C-level injuries for the driver of vehicle (B) but it does not indicate an injury level for the right-front passenger of vehicle (B). The driver of vehicle (B) was treated at the scene and the right-front passenger refused treatment.

### GENERAL VEHICLE DAMAGE AND ESTIMATED CRASH SEVERITIES

6 Damage to the front of case vehicle (A) was moderate. 7 8 Direct damage began at the right-front bumper corner and extended 65-cm to the right, resulting in 46% vehicle overlap (%VOL). The maximum crush was 32 cm and it occurred above the bumper at the right upper radiator support. The maximum bumper crush was 17 cm and it occurred at the right-front bumper corner.

9 Damage to the front of vehicle (B) was minor. 10 Direct damage began at the left-front bumper corner and extended 69-cm to the right, resulting in 47% VOL. 11 The maximum crush was 28 cm and it occurred at the left-front bumper corner. 12 The left wheelbase was reduced by 6 cm and 13 the right wheelbase was reduced by 3 cm.

Using the WinSMASH crash-reconstruction program and crush profiles measured for 14 15 16 case vehicle (A) and 17 18 19 vehicle (B), the following impact severities were estimated:

		Estimated Velocity Change - kph (mph)		
Vehicle	Variable	Total	Longitudinal	Latitudinal
Case vehicle (A)	delta V	29 (18)	-22 (-14)	-18 (-12)
Vehicle (B)	delta V	17 (11)	-17 (-10)	-3 (-2)

## DESCRIPTION OF DAMAGE TO CASE VEHICLE (A)

### Exterior

In the front, [20](#) the right sections of the bumper, the radiator, and the hood were crushed rearward and to the left, and the bumper cover was torn off. [21](#) The right bumper corner was shifted 40-cm to the left and [22](#) the left bumper corner was shifted 19-cm to the left. [23](#) The hood was buckled diagonally [24](#) [25](#) and the hood latch was damaged and released. [26](#) The right hood hinge was bent to the left [27](#) and the left hood hinge was bent up and rearward. [28](#) The rear section of the hood was elevated and the rear edge was folded under and it had contacted and cracked the left side of the windshield. [29](#) The right side of the windshield was cracked due to contact by the deploying dash-mounted airbag.

On the left side, [30](#) the fender was displaced rearward and buckled to the left, the lower section of the A-pillar was buckled, and [31](#) the upper section of the A-pillar was dented. [32](#) The driver and left-rear doors were closed and operational, and all left-side glazing was intact. There was no other left-side damage but the left wheelbase was reduced by 6 cm. [33](#) There was no damage to the rear of the case vehicle from this crash.

[34](#) On the right side, the front portion of the fender was displaced to the left. Both right-side doors were closed and operational and all right-side glazing was intact. There was no other right-side damage but the right wheelbase was increased by 2 cm.

### Interior

This vehicle was equipped with steering-wheel and dash-mounted frontal-impact airbags, and [35](#) [36](#) [37](#) both deployed during the frontal impact. In the driver area, there was no damage to [35](#) the deployed steering-wheel airbag or [38](#) [39](#) [40](#) [41](#) to the module cover. [44](#) There were scuffmarks on the knee bolster cover below the steering column but [42](#) [43](#) [45](#) there was no other damage in the driver area.

[46](#) There was no damage in the center-front area. In the right-front seating area, [47](#) there was no damage to the deployed dash-mounted airbag [48](#) [49](#) [50](#) but the module cover was scuffed from [51](#) contacting and cracking the windshield during deployment of the airbag. [52](#) [53](#) [54](#) There was no other damage in the right-front seating area.

[55](#) [56](#) There were no interior intrusions and there was no other interior damage.

## OCCUPANT KINEMATICS AND INJURIES

[57](#) The 160-cm, 73-kg (5-ft 3-in, 160-lb) 59-year-old female driver was using the three-point belt with pretensioner [58](#) and the steering-wheel airbag deployed. [59](#) Belt use at the time of the crash is indicated by belt loading marks on the D-ring and on the continuous loop of the sliding latch plate.

During the frontal impact, the driver moved forward and slightly to the right relative to the vehicle interior, into the three-point belt, airbag, and knee bolster. She sustained cervical strain, probably due to non-contact impact forces. She sustained a contusion to the left breast from loading by the shoulder belt, and she sustained a sprain to the left ankle, probably from foot contact with the toepan. She sustained a contusion to the left ankle, possibly from contact with the brake pedal, and she sustained a fracture to the proximal phalanx of the right fifth toe, probably from contact with the transmission tunnel or toepan.

The following table and attached drawing [62](#) summarize the injuries for the driver of case vehicle (A).

Occupant: Driver	Age: 59 years	Gender: Female		
Restraints: 3-point belt with pretensioner; steering-wheel airbag	Stature: 160 cm (5 ft, 3 in)	Mass: 73 kg (160 lb)		
Injury Description	A.I.S.	Injury Source		
		Definite	Probable	Possible
—	—	—	—	—
Cervical strain	1	—	Non-contact impact forces	—
Contusion, left breast	1	Shoulder belt	—	—
Sprain, left ankle	1	—	Toe pan	—
Contusion, left ankle	1	—	—	Brake pedal
Fracture, proximal phalanx of the right fifth toe	1	—	Transmission tunnel; toe pan	—
Maximum A.I.S. Level	1	—	—	—
Injury Severity Score	3	—	—	—

CASE NO.: 450

CASE VEHICLE: 2000 Hyundai

TYPE: Accent GL, 4-door sedan

OCCUPANT: Driver: 59-year-old female

STATURE: 160 cm (5 ft, 3 in) MASS: 73 kg (160 lb)

RESTRAINTS: 3-point belt with pretensioner;  
steering-wheel airbag

SEVERITY: MAIS - 1 : ISS - 3

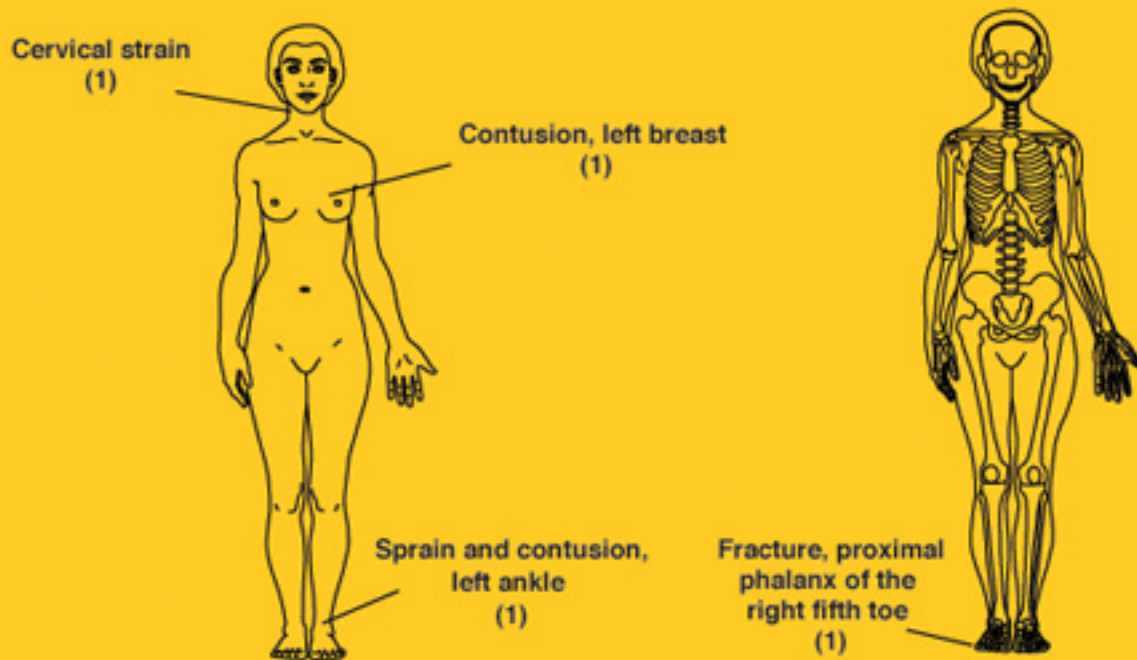

Case No.: 450

Case Veh. (A): 2000 Hyundai

Type: Accent GL, 4-door sedan

Driver: 59-year-old female

Veh. (B): 1998 Ford Explorer Sport, 4x2, 2-door SUV

Light Conditions: Daylight

Weather: Cloudy

Road Surface: Wet

Road Construction: Asphalt

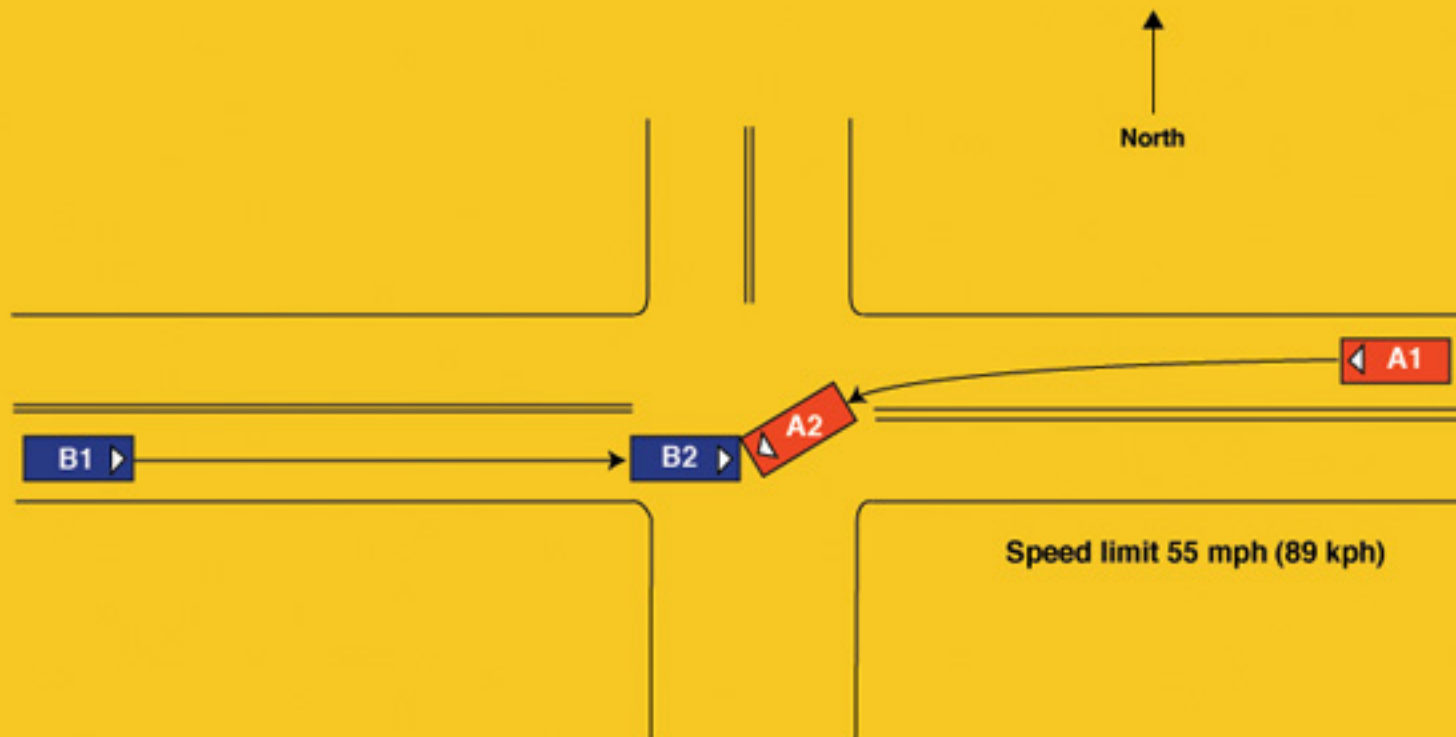

# UM-4263: Vehicle Report

Click on Section Name to jump directly to that Section —

- [General Information](#)
  - [Other Vehicle](#)
  - [Case Vehicle General](#)
  - [Case Vehicle Damage Description](#)
  - [Crash Reconstruction](#)
  - [Case Vehicle Tires & Rims](#)
  - [Case Vehicle Fuel Tank](#)
  - [Case Vehicle Fuel Leakage](#)
  - [Case Vehicle Fire](#)
  - [Case Vehicle Exterior](#)
  - [Case Vehicle Steering Column/Rim](#)
  - [Case Vehicle Intrusion](#)
  - [Case Vehicle Airbag\(s\)](#)
  - [Case Vehicle Interior](#)
  - [Case Vehicle Seats](#)
  - [Case Vehicle Side Airbag\(s\)](#)
  - [EDR -- Event Data Recorder](#)
- 

## General Information

[Back to Top](#)

Variable Number	Variable Name	Code Value	Code Description	Other Options
V0204	Collision Hour	0714	Time of day (24 hour clock)	<a href="#">more</a>
V0205	State Fips Code	26	Michigan	<a href="#">more</a>
V0206	Urban/rural Area	2	Rural	<a href="#">more</a>
V0207	Limited Access Highway	0	No	<a href="#">more</a>
V0208	Road Total Lanes	2	2 lanes	<a href="#">more</a>
V0209	Intersect Road Total Lanes	2	2 lanes	<a href="#">more</a>
V0210	Trafficway Flow	0	Not physically divided - two way traffic	<a href="#">more</a>
V0211	Road Surface Type	1	Asphalt	<a href="#">more</a>
V0212	Road Defects	0	No	<a href="#">more</a>
V0213	Construction Zone	0	No	<a href="#">more</a>
	Road Alignment Vertical			

V0214	Plane	1	Level	<a href="#">more</a>
V0215	Road Alignment Horizontal Plane	1	Straight	<a href="#">more</a>
V0216	Surface Covering	22	Water - wet	<a href="#">more</a>
V0217	Visibility Limitation	0	None	<a href="#">more</a>
V0218	Visibility Obstruction	0	None	<a href="#">more</a>
V0219	Speed Limit	6	86-90 km/h .. 55 mph	<a href="#">more</a>
V0220	Precipitation Type	0	None	<a href="#">more</a>
V0221	Precipitation Rate	8	Not applicable	<a href="#">more</a>
V0222	Temperature	9	Unknown	<a href="#">more</a>
V0223	Crosswind	9	Unknown	<a href="#">more</a>
V0224	Light Conditions	1	Daylight	<a href="#">more</a>
V0225	Mechanical Malfunction Mention	0	No	<a href="#">more</a>
V0226	Case Vehicle And Object	0	No	<a href="#">more</a>
V0227	Case Vehicle Rollover	0	No	<a href="#">more</a>
V0228	Rollover Location	0	No rollover	<a href="#">more</a>
V0229	Roll Direction	0	No rollover	<a href="#">more</a>
V0230	Rollover Initiation Type	0	No rollover	<a href="#">more</a>
V0231	Rollover Number Of Turns	0	No rollover	<a href="#">more</a>
V0232	Case Vehicle Preimpact Braking	1	Yes	<a href="#">more</a>
V0233	Case Vehicle Preimpact Stability	1	Case vehicle tracking before impact	<a href="#">more</a>
V0234	Case Vehicle Ran Off Roadway	0	No	<a href="#">more</a>
V0235	Moving Case Vehicle Contacted Moving Vehicle	1	Yes	<a href="#">more</a>
V0236	Case Vehicle Contacted Stopped Vehicle	0	No	<a href="#">more</a>
V0237	Stopped Case Vehicle Contacted Vehicle	0	No	<a href="#">more</a>
V0238	Total Vehicles Hit By Case Vehicle	1	1 vehicle	<a href="#">more</a>
V0239	Any Fire In Crash?	0	No	<a href="#">more</a>
V0240	Maximum Police Severity-acc	1	C - Possible Injury	<a href="#">more</a>
V0241	Driver Alcohol Involvmnt	0	Had not been drinking	<a href="#">more</a>
V0242	Driver Alcohol BAC (Case Vehicle)	80	No test	<a href="#">more</a>
V0243	Driver Impairment Mention	0	No	<a href="#">more</a>

V0244	Driver Distraction	01	Attentive or not distracted	<a href="#">more</a>
V0245	Driver Drug Involvement	0	None	<a href="#">more</a>
V0246	Driver Drug Type	0	No drug use	<a href="#">more</a>
V0247	Driven/towed From Scene	2	Towed Due to Damage	<a href="#">more</a>

## Other Vehicle

[Back to Top](#)

Variable Number	Variable Name	Code Value	Code Description	Other Options
V0301	Other Vehicle VIN	1FMYU22X3WXXXXXXX	<a href="#">Click for Contacted Vehicle figure</a>	<a href="#">more</a>
V0302	Other Vehicle Manufacturer/Body Code	12114	—	—
V0303	Other Vehicle Manufacturer	121	Ford	<a href="#">more</a>
V0304	Other Vehicle Body Code	14	Short wheelbase utility vehicle (Jeep, Bronco)	<a href="#">more</a>
V0305	Other Vehicle Make/model	3131	Explorer MPV	<a href="#">more</a>
V0306	Other Vehicle Model Year	1998	Year	<a href="#">more</a>
V0307	Other Vehicle Mass	001675 kg	Mass (Kg.)	<a href="#">more</a>
V0308	Other Vehicle Number	1	Vehicle #1	<a href="#">more</a>
V0309	Other Vehicle Number of Occupants	02	number of occupants	<a href="#">more</a>
V0310	Other Vehicle Traveling Speed	999	Unknown	<a href="#">more</a>
V0311	Highest Police Injury Severity	1	C - Possible Injury	<a href="#">more</a>
V0312	Other Vehicle Type	14	Small utility (wheelbase <107", e.g. Jeep)	<a href="#">more</a>
V0313	Other Vehicle Wheelbase in Centimeters	258 cm	Actual Wheelbase (cm)	<a href="#">more</a>
V0314	Other Vehicle Average Track Width	149 cm	actual measurement (cm)	<a href="#">more</a>
V0315	Other Vehicle Overall Length	456 cm	actual measurement (cm)	<a href="#">more</a>
V0316	Other Vehicle Overall Width (OAW)	178 cm	actual measurement (cm)	<a href="#">more</a>
	Other Vehicle Front			



V0317	Overhang	086 cm	actual measurement (cm)	<a href="#">more</a>
V0318	Other Vehicle Rear Overhang	112 cm	actual measurement (cm)	<a href="#">more</a>
V0319	Other Vehicle Undeformed End Width (UEW)	150 cm	actual measurement (cm)	<a href="#">more</a>
V0320	Other Vehicle Engine Displacement	4.0 l	Liters	<a href="#">more</a>
V0321	Other Vehicle Engine: Number of Cylinders	06	number of cylinders	<a href="#">more</a>
V0322	Other Vehicle Direct Damage Length (DDL)	069 cm	actual measurement (cm)	<a href="#">more</a>
V0323	Other Vehicle Front-End Overlap	46	percentage (%)	<a href="#">more</a>
V0324	Other Vehicle - Vehicle Overlap	47	percentage (%)	<a href="#">more</a>

### Case Vehicle General

[Back to Top](#)

Variable Number	Variable Name	Code Value	Code Description	Other Options
V0401	VIN	KMHCG45G8YXXXXXXX	<a href="#">Click for Case Vehicle figure</a>	<a href="#">more</a>
V0402	Manufacturer/Body Code	93926	—	—
V0403	Vehicle Manufacturer	939	Hyundai	<a href="#">more</a>
V0404	Vehicle Body Code	26	Sub-Compact 95-99.9 in. wb.	<a href="#">more</a>
V0405	Make/model Code	4703	Accent	<a href="#">more</a>
V0406	Model Year	2000	Model year	<a href="#">more</a>
V0407	Vehicle Mass	001066 kg	Mass (Kg)	<a href="#">more</a>
V0408	Odometer Reading	081313	—	—
V0409	Number of Occupants	01	1 occupant	<a href="#">more</a>
V0410	Traveling Speed	999	Unknown	<a href="#">more</a>
V0411	Body Type	14	4-door sedan	<a href="#">more</a>
V0412	Stolen Vehicle	8	Not currently collected	<a href="#">more</a>
V0413	Body Structure	2	Unitized	<a href="#">more</a>
V0414	Transmission Type	1	Automatic	<a href="#">more</a>
V0415	Transmission Lever Location	2	Console	<a href="#">more</a>
V0416	Steering	1	Power	<a href="#">more</a>
V0417	Brakes	1	Power	<a href="#">more</a>

V0418	Brake Type	2	Disc - front wheels	<a href="#">more</a>
V0419	Adjustable Pedals?	0	No	<a href="#">more</a>
V0420	Brake Anti-lock Device	0	None installed	<a href="#">more</a>
V0421	Air Conditioning in Vehicle	8	Not currently collected	<a href="#">more</a>
V0422	Drive Type	2	Front wheel	<a href="#">more</a>
V0423	Dual Rear Wheels	0	No	<a href="#">more</a>
V0424	Original Restraint System Type	3	Air bag	<a href="#">more</a>
V0425	Equipped With Roll Bar	0	No	<a href="#">more</a>
V0426	Roof Type	1	Solid	<a href="#">more</a>
V0427	Case Vehicle Wheelbase in Centimeters	244 cm	Actual Wheelbase	<a href="#">more</a>
V0428	Anti-lacerative Glass	8	Not Collected	<a href="#">more</a>
V0429	Case Vehicle average track Width	143 cm	actual measurement (cm)	<a href="#">more</a>
V0430	Case Vehicle Overall Length	423 cm	actual measurement (cm)	<a href="#">more</a>
V0431	Case Vehicle Overall Width (OAW)	169	actual measurement (cm)	<a href="#">more</a>
V0432	Case Vehicle Front Overhang	084 cm	actual measurement (cm)	<a href="#">more</a>
V0433	Case Vehicle Rear Overhang	098 cm	actual measurement (cm)	<a href="#">more</a>
V0434	Case Vehicle Undeformed End Width (UEW)	144 cm	actual measurement (cm)	<a href="#">more</a>
V0435	Case Vehicle Engine Displacement	1.5 l	Liters	<a href="#">more</a>
V0436	Case Vehicle Engine: Number of Cylinders	04	number of cylinders	<a href="#">more</a>
V0437	Case Vehicle Direct Damage Length (DDL)	065 cm	actual measurement (cm)	<a href="#">more</a>
V0438	Case Vehicle Front-end Overlap	45	percentage (%)	<a href="#">more</a>
V0439	Case Vehicle - Vehicle Overlap	46	percentage (%)	<a href="#">more</a>

## Case Vehicle Damage Description

[Back to Top](#)

<b>Variable Number</b>	<b>Variable Name</b>	<b>Code Value</b>	<b>Code Description</b>	<b>Other Options</b>
V0501	Maximum Sheet Metal Crush - Front	032 cm	Depth of Crush (cm)	<a href="#">more</a>
V0502	Maximum Sheet Metal Crush - Rear	000 cm	No Crush (or less than 1 cm.)	<a href="#">more</a>
V0503	Maximum Sheet Metal Crush - Roof	000 cm	No Crush (or less than 1 cm.)	<a href="#">more</a>
V0504	Maximum Sheet Metal Crush - Right Side	000 cm	No Crush (or less than 1 cm.)	<a href="#">more</a>
V0505	Maximum Sheet Metal Crush - Left Side	000 cm	No Crush (or less than 1 cm.)	<a href="#">more</a>
V0506	Maximum Sheet Metal Crush - Other	000 cm	No Crush (or less than 1 cm.)	<a href="#">more</a>
V0507	Seq In Chronological Ord	1	Yes	<a href="#">more</a>
V0508	Event 1 -impact Location	1	On Roadway	<a href="#">more</a>
V0509	Event 1 -Impact Configuration	11	FRONT of case veh - FRONT of contacted veh	<a href="#">more</a>
V0510	Event 1 -Object/Vehicle Contactd	14	Small utility (wheelbase <107", e.g. Jeep)	<a href="#">more</a>
V0511	Event 2 -impact Location	8	No 2nd event	<a href="#">more</a>
V0512	Event 2 -Impact Configuration	88	No 2nd event	<a href="#">more</a>
V0513	Event 2 -Object/Vehicle Contactd	00	No object/vehicle contacted	<a href="#">more</a>
V0514	Event 3 -impact Location	8	No 3rd event	<a href="#">more</a>
V0515	Event 3 -Impact Configuration	88	No 3rd event	<a href="#">more</a>
V0516	Event 3 -Object/Vehicle Contactd	00	No object/vehicle contacted	<a href="#">more</a>
V0517	Event 4 -impact Location	8	No 4th event	<a href="#">more</a>
V0518	Event 4 -Impact Configuration	88	No 4th event	<a href="#">more</a>
V0519	Event 4 -Object/Vehicle Contactd	00	No object/vehicle contacted	<a href="#">more</a>
V0520	Event 5 -impact Location	8	No 5th event	<a href="#">more</a>
V0521	Event 5 -Impact Configuration	88	No 5th event	<a href="#">more</a>
V0522	Event 5 -Object/Vehicle Contactd	00	No object/vehicle contacted	<a href="#">more</a>
V0523	Event 6 -impact Location	8	No 6th event	<a href="#">more</a>
	Event 6 -Impact			

V0524	Configuration	88	No 6th event	<a href="#">more</a>
V0525	Event 6 -Object/Vehicle Contactd	00	No object/vehicle contacted	<a href="#">more</a>
V0526	Event 7 -impact Location	8	No 7th event	<a href="#">more</a>
V0527	Event 7 -Impact Configuration	88	No 7th event	<a href="#">more</a>
V0528	Event 7 -Object/Vehicle Contactd	00	No object/vehicle contacted	<a href="#">more</a>
V0529	Primary CDC Case Vehicle - event Number	1	Event 1	<a href="#">more</a>
V0530	Primary CDC Case Vehicle - Impact Speed (kph)	999	Unknown	<a href="#">more</a>
V0531	Primary CDC Case Vehicle- estimatr	1	Investigator	<a href="#">more</a>
V0532	Primary CDC Case Vehicle - Crush (CM)	032	Crush measurements in cm	<a href="#">more</a>
V0533	Primary CDC Case Vehicle- clock #1	01	1 o'clock	<a href="#">more</a>
V0534	Primary CDC Case Vehicle- Letter 1 #1	06	F - Front	<a href="#">more</a>
V0535	Primary CDC Case Vehicle- Letter 2 #1	26	Z - Side or end (B + P or R + C)	<a href="#">more</a>
V0536	Primary CDC Case Vehicle- Letter 3 #1	05	E - Everything below belt line	<a href="#">more</a>
V0537	Primary CDC Case Vehicle- Letter 4 #1	23	W - Wide impact area	<a href="#">more</a>
V0538	Primary CDC Case Vehicle - Extent #1	2	—	—
V0539	Primary CDC - Contacted Vehicles Assoc CDC - CDC #1	01FZEW2	—	—
V0540	Primary CDC Case Vehicle- clock #2	98	Not Applicable	<a href="#">more</a>
V0541	Primary CDC Case Vehicle- Letter 1 #2	00	Missing Data/Not applicable	<a href="#">more</a>
V0542	Primary CDC Case Vehicle- Letter 2 #2	00	Missing Data/Not applicable	<a href="#">more</a>
V0543	Primary CDC Case Vehicle- Letter 3 #2	00	Missing Data/Not applicable	<a href="#">more</a>
V0544	Primary CDC Case Vehicle- Letter 4 #2	00	Missing Data/Not applicable	<a href="#">more</a>
V0545	Primary CDC Case Vehicle - Extent #2	0	—	—

V0546	Primary CDC - Case Vehicle Assoc CDC - CDC #2	9800000	—	—
V0547	Primary CDC Contacted Vehicle - Impact Speed (kph)	999	Unknown	<a href="#">more</a>
V0548	Primary CDC Contacted Vehicle-estimator	1	Investigator	<a href="#">more</a>
V0549	Primary CDC Contacted Vehicle - Crush (CM)	028	Crush measurements in cm	<a href="#">more</a>
V0550	Primary CDC Contacted Vehicle-clock #1	12	12 o'clock	<a href="#">more</a>
V0551	Primary CDC Contacted Vehicle-Letter 1 #1	06	F - Front	<a href="#">more</a>
V0552	Primary CDC Contacted Vehicle-Letter 2 #1	25	Y - Side or end (F + P or L + C)	<a href="#">more</a>
V0553	Primary CDC Contacted Vehicle-Letter 3 #1	05	E - Everything below belt line	<a href="#">more</a>
V0554	Primary CDC Contacted Vehicle-Letter 4 #1	23	W - Wide impact area	<a href="#">more</a>
V0555	Primary CDC Contacted Vehicle - Extent #1	2	—	—
V0556	primary CDC - Contacted Vehicles Assoc CDC - CDC #1	12FYEW2	—	—
V0557	Primary CDC Contacted Vehicle-clock #2	98	Not Applicable	<a href="#">more</a>
V0558	Primary CDC Contacted Vehicle-Letter 1 #2	00	Missing Data/Not applicable	<a href="#">more</a>
V0559	Primary CDC Contacted Vehicle-Letter 2 #2	00	Missing Data/Not applicable	<a href="#">more</a>
V0560	Primary CDC Contacted Vehicle-Letter 3 #2	00	Missing Data/Not applicable	<a href="#">more</a>
V0561	Primary CDC Contacted Vehicle-Letter 4 #2	00	Missing Data/Not applicable	<a href="#">more</a>
V0562	Primary CDC Contacted Vehicle - Extent #2	0	—	—
V0563	Primary CDC - Contacted Vehicles Assoc CDC - CDC #2	9800000	—	—
V0564	Secondary CDC Case Vehicle-event No	8	Not applicable	<a href="#">more</a>
V0565	Secondary CDC Case Vehicle - Impact Speed (kph)	998	Not Applicable	<a href="#">more</a>

V0566	Secondary CDC Case Vehicle-estimator	8	Not applicable (no vehicle/no impact)	<a href="#">more</a>
V0567	Secondary CDC Case Vehicle - Crush (CM)	998	Not Applicable	<a href="#">more</a>
V0568	Secondary CDC Case Vehicle-clock #1	98	Not Applicable	<a href="#">more</a>
V0569	Secondary CDC Case Vehicle-Letter 1 #1	00	Missing Data/Not applicable	<a href="#">more</a>
V0570	Secondary CDC Case Vehicle-Letter 2 #1	00	Missing Data/Not applicable	<a href="#">more</a>
V0571	Secondary CDC Case Vehicle-Letter 3 #1	00	Missing Data/Not applicable	<a href="#">more</a>
V0572	Secondary CDC Case Vehicle-Letter 4 #1	00	Missing Data/Not applicable	<a href="#">more</a>
V0573	SECONDARY CDC CASE VEHICLE - EXTENT #1	0	—	—
V0574	Secondary CDC - Case Vehicle Assoc CDC - CDC #1	9800000	—	—
V0575	Secondary CDC Case Vehicle-clock #2	98	Not Applicable	<a href="#">more</a>
V0576	Secondary CDC Case Vehicle-Letter 1 #2	00	Missing Data/Not applicable	<a href="#">more</a>
V0577	Secondary CDC Case Vehicle-Letter 2 #2	00	Missing Data/Not applicable	<a href="#">more</a>
V0578	Secondary CDC Case Vehicle-Letter 3 #2	00	Missing Data/Not applicable	<a href="#">more</a>
V0579	Secondary CDC Case Vehicle-Letter 4 #2	00	Missing Data/Not applicable	<a href="#">more</a>
V0580	SECONDARY CDC CASE VEHICLE - EXTENT #2	0	—	—
V0581	Secondary CDC - Case Vehicle Assoc CDC - CDC #2	9800000	—	—
V0582	Secondary CDC Contacted Vehicle - Impact Speed (kph)	998	Not Applicable	<a href="#">more</a>
V0583	Secondary CDC Contacted Vehicle-estimator	8	Not applicable (no vehicle/no impact)	<a href="#">more</a>
V0584	Secondary CDC Contacted Vehicle - Crush (CM)	998	Not Applicable	<a href="#">more</a>
V0585	Secondary CDC Contacted Vehicle-clock #1	98	Not Applicable	<a href="#">more</a>
	Secondary CDC Contacted			

V0586	Vehicle-Letter 1 #1	00	Missing Data/Not applicable	<a href="#">more</a>
V0587	Secondary CDC Contacted Vehicle-Letter 2 #1	00	Missing Data/Not applicable	<a href="#">more</a>
V0588	Secondary CDC Contacted Vehicle-Letter 3 #1	00	Missing Data/Not applicable	<a href="#">more</a>
V0589	Secondary CDC Contacted Vehicle-Letter 4 #1	00	Missing Data/Not applicable	<a href="#">more</a>
V0590	Secondary CDC Contacted Vehicle - Extent #1	0	—	—
V0591	Secondary CDC - Contacted Vehicle Assoc CDC - CDC #1	9800000	—	—
V0592	Secondary CDC Contacted Vehicle-clock #2	98	Not Applicable	<a href="#">more</a>
V0593	Secondary CDC Contacted Vehicle-Letter 1 #2	00	Missing Data/Not applicable	<a href="#">more</a>
V0594	Secondary CDC Contacted Vehicle-Letter 2 #2	00	Missing Data/Not applicable	<a href="#">more</a>
V0595	Secondary CDC Contacted Vehicle-Letter 3 #2	00	Missing Data/Not applicable	<a href="#">more</a>
V0596	Secondary CDC Contacted Vehicle-Letter 4 #2	00	Missing Data/Not applicable	<a href="#">more</a>
V0597	Secondary CDC Contacted Vehicle - Extent #2	0	—	—
V0598	Secondary CDC - Contacted Vehicle Assoc CDC - CDC #2	9800000	—	—

## Crash Reconstruction

[Back to Top](#)

Variable Number	Variable Name	Code Value	Code Description	Other Options
V0601	Primary Delta-V Case Vehicle-event #	1	Event number 1	<a href="#">more</a>
V0602	Primary Delta V Case Vehicle - Total Delta V	029 kph	kph	<a href="#">more</a>
V0603	Primary delta-V Case Vehicle -LONGITUD	-022	—	—
V0604	Primary delta-V Case Vehicle-Lateral	-018	—	—
V0605	Primary Delta V Case Vehicle - Energy Dissipated	0065	—	—

	by Crush (k			
V0606	Primary Delta-V Case Vehicle-Reconstruction	22	Reconstructed, moderate confidence level	<a href="#">more</a>
V0607	Primary Delta-V Case Vehicle- Mode	2	CDC & detailed damage	<a href="#">more</a>
V0608	Primary Delta V Contacted Vehicle - Total Delta V	017 kph	kph	<a href="#">more</a>
V0609	Primary delta-V Contacted Vehicle-LONGITUD	-017	—	—
V0610	Primary delta-V Contacted Vehicle-Lateral	-003	—	—
V0611	Primary delta-V Contacted Vehicle - Energy Dissipated by Cru	0020	—	—
V0612	Secondary Delta-V Case Vehicle-event #	8	Not applicable	<a href="#">more</a>
V0613	Secondary Delta V Case Vehicle - Total Delta V	888	Not applicable	<a href="#">more</a>
V0614	Secondarydelta-V Case Vehicle -LONGITUD	8888	—	—
V0615	Secondary delta-V Case Vehicle-Lateral	8888	—	—
V0616	Secondary delta-V Case Vehicle - Energy Dissipated by Crush	8888	—	—
V0617	Secondary Delta-V Case Vehicle-Reconstruction	88	Not applicable	<a href="#">more</a>
V0618	Secondary Delta-V Case Vehicle- Mode	8	Not applicable	<a href="#">more</a>
V0619	Secondary Delta V Contacted Vehicle - Total Delta V	888	Not applicable	<a href="#">more</a>
V0620	Secondary delta-V Contacted Vehicle-LONGITUD	8888	—	—
V0621	Secondary delta-V Contacted Vehicle-Lateral	8888	—	—
V0622	Secondary delta-V Contacted Vehicle - Energy Dissipated By C	8888	—	—
V0623	Primary EBS Case Vehicle-event #	1	Event number 1	<a href="#">more</a>
	Primary EBS Case Vehicle -			



V0624	Total EBS	031 kph	kph	<a href="#">more</a>
V0625	Primary EBS Case Vehicle - LONGITUD	-023	—	—
V0626	Primary EBS Case Vehicle-Lateral	-020	—	—
V0627	Primary EBS Case Vehicle - Energy Dissipated by Crush (kj)	0065	—	—
V0628	Primary EBS Case Vehicle-Reconstruction	22	Reconstructed, moderate confidence level	<a href="#">more</a>
V0629	Primary EBS Case Vehicle-Mode	2	CDC & detailed damage	<a href="#">more</a>
V0630	Primary EBS Contacted Vehicle - Total EBS	014 kph	kph	<a href="#">more</a>
V0631	Primary EBS Contacted Vehicle-LONGITUD	-014	—	—
V0632	Primary EBS Contacted Vehicle-Lateral	-003	—	—
V0633	Primary EBS Contact Vehicle - Energy Dissipated by Crush (kj)	0020	—	—
V0634	Secondary EBS Case Vehicle-event #	8	Not applicable	<a href="#">more</a>
V0635	Secondary EBS Case Vehicle - Total EBS	888	Not Applicable	<a href="#">more</a>
V0636	Secondary EBS Case Vehicle -LONGITUD	8888	—	—
V0637	Secondary EBS Case Vehicle-Lateral	8888	—	—
V0638	Secondary EBS Case Vehicle - Energy Dissipated by Crush (kj)	8888	—	—
V0639	Secondary EBS Case Vehicle-Reconstruction	88	Not applicable	<a href="#">more</a>
V0640	Secondary EBS Case Vehicle- Mode	8	Not applicable	<a href="#">more</a>
V0641	Secondary EBS Contacted Vehicle - Total EBS	888	Not Applicable	<a href="#">more</a>
V0642	Secondary EBS Contacted Vehicle-LONGITUD	8888	—	—
V0643	Secondary EBS Contacted Vehicle-Lateral	8888	—	—

V0644	Secondary EBS Contact Vehicle - Energy Dissipated by Crush (	8888	—	—
V0645	Specific Event # Case(1)	1	Event number 1	<a href="#">more</a>
V0646	Plane of Impact Case Vehicle (1)	5	Other	<a href="#">more</a>
V0647	Direct Damage Length (DDL) - Case Vehicle (1)	065 cm	cm	<a href="#">more</a>
V0648	Direct Damage Maximum Crush - Case Vehicle (1)	032 cm	cm	<a href="#">more</a>
V0649	Direct and Induced Damage Length in CM	124 cm	cm	<a href="#">more</a>
V0650	Field C1 - Case Vehicle (1)	000 cm	No Crush	<a href="#">more</a>
V0651	Field C2 - Case Vehicle (1)	009 cm	cm	<a href="#">more</a>
V0652	Field C3 - Case Vehicle (1)	015 cm	cm	<a href="#">more</a>
V0653	Field C4 - Case Vehicle (1)	021 cm	cm	<a href="#">more</a>
V0654	Field C5 - Case Vehicle (1)	016 cm	cm	<a href="#">more</a>
V0655	Field C6 - Case Vehicle (1)	017 cm	cm	<a href="#">more</a>
V0656	Direct Damage D Value = The Center of Direct Damage Offset t	+035 cm	Offset (cm)	<a href="#">more</a>
V0657	Specific Event # Case(2)	1	Event number 1	<a href="#">more</a>
V0658	Plane of Impact Case Vehicle(2)	5	Other	<a href="#">more</a>
V0659	Direct Damage Length (DDL) - Case Vehicle (2)	065 cm	cm	<a href="#">more</a>
V0660	Direct Damage Maximum Crush - Case Vehicle (2)	032 cm	cm	<a href="#">more</a>
V0661	Direct and Induced Damage Length in CM	124 cm	cm	<a href="#">more</a>
V0662	Field C1 - Case Vehicle (2)	000 cm	No Crush	<a href="#">more</a>
V0663	Field C2 - Case Vehicle (2)	009 cm	cm	<a href="#">more</a>
V0664	Field C3 - Case Vehicle (2)	015 cm	cm	<a href="#">more</a>
V0665	Field C4 - Case Vehicle (2)	021 cm	cm	<a href="#">more</a>
V0666	Field C5 - Case Vehicle (2)	016 cm	cm	<a href="#">more</a>
V0667	Field C6 - Case Vehicle (2)	017 cm	cm	<a href="#">more</a>
V0668	Direct Damage D Value = The Center of Direct Damage Offset t	+035 cm	cm	<a href="#">more</a>
V0669	Specific Event # Cont(1)	1	Event number 1	<a href="#">more</a>

V0670	Plane of Impact Contacted Vehicle(1)	1	Bumper	<a href="#">more</a>
V0671	Direct Damage Length (DDL) - Contacted Vehicle (1)	069 cm	cm	<a href="#">more</a>
V0672	Direct Damage Maximum Crush - Contacted Vehicle (1)	028 cm	cm	<a href="#">more</a>
V0673	Field L - Contacted Vehicle (1)	139 cm	cm	<a href="#">more</a>
V0674	Field C1 - Contacted Vehicle (1)	028 cm	cm	<a href="#">more</a>
V0675	Field C2 - Contacted Vehicle (1)	007 cm	cm	<a href="#">more</a>
V0676	Field C3 - Contacted Vehicle (1)	003 cm	cm	<a href="#">more</a>
V0677	Field C4 - Contacted Vehicle (1)	001 cm	cm	<a href="#">more</a>
V0678	Field C5 - Contacted Vehicle (1)	000 cm	No Crush	<a href="#">more</a>
V0679	Field C6 - Contacted Vehicle (1)	000 cm	No Crush	<a href="#">more</a>
V0680	Direct Damage D Value = The Center of Direct Damage Offset t	-041 cm	offset (cm)	<a href="#">more</a>
V0681	Specific Event # Contacted Vehicle (2)	1	Event number	<a href="#">more</a>
V0682	Plane of Impact Contacted Vehicle(2)	1	Bumper	<a href="#">more</a>
V0683	Direct Damage Length (DDL) - Contacted Vehicle (2)	069 cm	cm	<a href="#">more</a>
V0684	Direct Damage Maximum Crush - Contacted Vehicle (2)	028 cm	cm	<a href="#">more</a>
V0685	Direct and Induced Damage Length in CM	139 cm	cm	<a href="#">more</a>
V0686	Field C1 - Contacted Vehicle (2)	028 cm	cm	<a href="#">more</a>
V0687	Field C2 - Contacted Vehicle (2)	007 cm	cm	<a href="#">more</a>
V0688	Field C3 - Contacted Vehicle (2)	003 cm	cm	<a href="#">more</a>
	Field C4 - Contacted Vehicle	001 cm		

V0689	(2)		cm	<a href="#">more</a>
V0690	Field C5 - Contacted Vehicle (2)	000 cm	No Crush	<a href="#">more</a>
V0691	Field C6 - Contacted Vehicle (2)	000 cm	No Crush	<a href="#">more</a>
V0692	Direct Damage D Value = The Center of Direct Damage Offset t	-041 cm	Offset (cm)	<a href="#">more</a>

## Case Vehicle Tires & Rims

[Back to Top](#)

Variable Number	Variable Name	Code Value	Code Description	Other Options
V0701	Left Front Wheel Damaged	0	No	<a href="#">more</a>
V0702	Right Front Wheel Damaged	0	No	<a href="#">more</a>
V0703	Right Rear Wheel Damaged	0	No	<a href="#">more</a>
V0704	Left Rear Wheel Damaged	0	No	<a href="#">more</a>
V0705	Left Front Tire Tread Type	4	All Weather	<a href="#">more</a>
V0706	Right Front Tire Tread Type	4	All Weather	<a href="#">more</a>
V0707	Right Rear Tire Tread Type	4	All Weather	<a href="#">more</a>
V0708	Left Rear Tire Tread Type	4	All Weather	<a href="#">more</a>
V0709	Left Front Carcass Construction	3	Radial	<a href="#">more</a>
V0710	Right Front Carcass Construction	3	Radial	<a href="#">more</a>
V0711	Right Rear Carcass Construction	3	Radial	<a href="#">more</a>
V0712	Left Rear Carcass Construction	3	Radial	<a href="#">more</a>
V0713	Left Front Tire Condition Precrash	0	Normal - no pre-crash problems	<a href="#">more</a>
V0714	Right Front Tire Condition Precrash	0	Normal - no pre-crash problems	<a href="#">more</a>
V0715	Right Rear Tire Condition Precrash	0	Normal - no pre-crash problems	<a href="#">more</a>
V0716	Left Rear Tire Condition Precrash	0	Normal - no pre-crash problems	<a href="#">more</a>
V0717	Left Front Tire Condition Postcrash	0	Normal - no damage to tire	<a href="#">more</a>
	Right Front Tire Condition			

V0718	Postcrash	0	Normal - no damage to tire	<a href="#">more</a>
V0719	Right Rear Tire Condition Postcrash	0	Normal - no damage to tire	<a href="#">more</a>
V0720	Left Rear Tire Condition Postcrash	0	Normal - no damage to tire	<a href="#">more</a>
V0721	Left Front Tire Involvement	0	No	<a href="#">more</a>
V0722	Right Front Tire Involvement	0	No	<a href="#">more</a>
V0723	Right Rear Tire Involvement	0	No	<a href="#">more</a>
V0724	Left Rear Tire Involvement	0	No	<a href="#">more</a>
V0725	Left Front Tire Size	P17570R13	—	—
V0726	Right Front Tire Size	P17570R13	—	—
V0727	Right Rear Tire Size	P17570R13	—	—
V0728	Left Rear Tire Size	P17570R13	—	—
V0729	Left Front Tire Pressure (recorded in psi)	10.0 psi	Actual tire pressure in psi	<a href="#">more</a>
V0730	Right Front Tire Pressure (recorded in psi)	09.0 psi	Actual tire pressure in psi	<a href="#">more</a>
V0731	Right Rear Tire Pressure (recorded in psi)	10.0 psi	Actual tire pressure in psi	<a href="#">more</a>
V0732	Left Rear Tire Pressure (recorded in psi)	10.0 psi	Actual tire pressure in psi	<a href="#">more</a>
V0733	Left Front Tread Depth	26	26/32"	<a href="#">more</a>
V0734	Right Front Tread Depth	25	25/32"	<a href="#">more</a>
V0735	Right Rear Tread Depth	26	26/32"	<a href="#">more</a>
V0736	Left Rear Tread Depth	26	26/32"	<a href="#">more</a>

### Case Vehicle Fuel Tank

[Back to Top](#)

Variable Number	Variable Name	Code Value	Code Description	Other Options
V0801	Propulsive Fuel Type	1	Gasoline	<a href="#">more</a>
V0802	Main Tank Location	322	Within frame/centered laterally - within vertical	<a href="#">more</a>
V0803	Main Filler Cap Location	113	Left of frame laterally - above vertically	<a href="#">more</a>
V0804	Main Tank Material	3	Plastic	<a href="#">more</a>
V0805	Aux Tank Type	8	Not applicable (not equipped)	<a href="#">more</a>
V0806	Aux Tank Location	888	Not applicable (not equipped)	<a href="#">more</a>

V0807	Aux Filler Cap Location	888	Not applicable (not equipped)	<a href="#">more</a>
V0808	Aux Tank Material	8	Not applicable	<a href="#">more</a>

### Case Vehicle Fuel Leakage

[Back to Top](#)

Variable Number	Variable Name	Code Value	Code Description	Other Options
V0901	Fuel Leakage From Crash	0	No	<a href="#">more</a>

### Case Vehicle Fire

[Back to Top](#)

Variable Number	Variable Name	Code Value	Code Description	Other Options
V1001	Fire In Or On Case Vehicle	0	No	<a href="#">more</a>

### Case Vehicle Exterior

[Back to Top](#)

Variable Number	Variable Name	Code Value	Code Description	Other Options
V1101	Hood Latch Released	1	Yes	<a href="#">more</a>
V1102	Hood Latch Damaged	1	Yes	<a href="#">more</a>
V1103	Hood Latch Jammed	0	No	<a href="#">more</a>
V1104	Left Hood Hinge Damaged	1	Yes	<a href="#">more</a>
V1105	Left Hood Hinge Separated	0	No	<a href="#">more</a>
V1106	Right Hood Hinge Damaged	1	Yes	<a href="#">more</a>
V1107	Right Hood Hinge Separated	0	No	<a href="#">more</a>
V1108	Hood Remained On Vehicle	1	Yes	<a href="#">more</a>
V1109	Rear Hood Edge Elevated	1	Yes	<a href="#">more</a>
V1110	Edge Contacted Windshield	1	Yes	<a href="#">more</a>
V1111	Edge Penetrated Windshield	0	No	<a href="#">more</a>
V1112	Hood Latch Location	1	Front of Vehicle	<a href="#">more</a>
V1113	Eng/transmissn Mount Separated	0	No	<a href="#">more</a>
V1114	Steering Column Flex Couplng	9	Unknown if equipped	<a href="#">more</a>
V1115	Steering Column Coupling Dam	9	Unknown	<a href="#">more</a>
V1116	Steering Column Coupling Separated	9	Unknown	<a href="#">more</a>

V1117	Eng Comp Telescopng Unit	88	Not currently collected	<a href="#">more</a>
V1118	Compartment Unit's Original/telescoped Length Difference	888	Not currently collected	<a href="#">more</a>
V1119	Left Side Body Mount Separated	8	Not applicable (unitized)	<a href="#">more</a>
V1120	Upper Left A-pillar Sep	4	No separation, but damaged	<a href="#">more</a>
V1121	Lower Left A-pillar Sep	4	No separation, but damaged	<a href="#">more</a>
V1122	Upper Left B-pillar Sep	0	No	<a href="#">more</a>
V1123	Lower Left B-pillar Sep	0	No	<a href="#">more</a>
V1124	Upper Left C-pillar Sep	0	No	<a href="#">more</a>
V1125	Lower Left C-pillar Sep	0	No	<a href="#">more</a>
V1126	Upper Left D-pillar Sep	8	Not applicable (not equipped)	<a href="#">more</a>
V1127	Lower Left D-pillar Sep	8	Not applicable (not equipped)	<a href="#">more</a>
V1128	Left Front Door Opening Cause	00	Door did not open	<a href="#">more</a>
V1129	Left Rear Door Opening Cause	00	Door did not open	<a href="#">more</a>
V1130	Left Front Door Jammed Closed	0	No	<a href="#">more</a>
V1131	Left Rear Door Jammed Closed	0	No	<a href="#">more</a>
V1132	Van Left Rear Door Type	8	Not applicable (not a van)	<a href="#">more</a>
V1133	Left Front Glazing Availability	2	Closed	<a href="#">more</a>
V1134	Left Rear Glazing Availability	2	Closed	<a href="#">more</a>
V1135	Lr2 Glazing Availability	1	Fixed	<a href="#">more</a>
V1136	Left Front Glazing Damage	0	No damage	<a href="#">more</a>
V1137	Left Rear Glazing Damage	0	No damage	<a href="#">more</a>
V1138	Lr2 Glazing Damage	0	No damage	<a href="#">more</a>
V1139	Rear Door Type	0	No door (includes pickups)	<a href="#">more</a>
V1140	Rear Door Opening Cause	8	Not applicable (no rear door)	<a href="#">more</a>
V1141	Rear Door Jammed Closed	8	Not applicable (no rear door)	<a href="#">more</a>
V1142	Rear Glazng Availability	8	Not Applicable (No Door)	<a href="#">more</a>
V1143	Rear Glazing Damage	8	Not Applicable (No Door)	<a href="#">more</a>
V1144	Luggage Partition Damaged	0	No	<a href="#">more</a>
V1145	Spare Tire Status	8	Not collected	<a href="#">more</a>
V1146	Trailer Hitch Type	0	No hitch	<a href="#">more</a>
V1147	Trailer Type	0	No trailer	<a href="#">more</a>

V1148	Rght Side Body Mount Separated	8	Not applicable (unitized)	<a href="#">more</a>
V1149	Upper Right A-pillar Separated	0	No	<a href="#">more</a>
V1150	Lower Right A-pillar Separated	0	No	<a href="#">more</a>
V1151	Upper Right B-pillar Separated	0	No	<a href="#">more</a>
V1152	Lower Right B-pillar Separated	0	No	<a href="#">more</a>
V1153	Upper Right C-pillar Separated	0	No	<a href="#">more</a>
V1154	Lower Right C-pillar Separated	0	No	<a href="#">more</a>
V1155	Upper Right D-pillar Separated	8	Not applicable (not equipped)	<a href="#">more</a>
V1156	Lower Right D-pillar Separated	8	Not applicable (not equipped)	<a href="#">more</a>
V1157	Right Front Door Opening Cause	00	Door did not open	<a href="#">more</a>
V1158	Right Rear Door Opening Cause	00	Door did not open	<a href="#">more</a>
V1159	Right Front Door Jammed Closed	0	No	<a href="#">more</a>
V1160	Right Rear Door Jammed Closed	0	No	<a href="#">more</a>
V1161	Van Right-rear Door Type	8	Not applicable (not a van)	<a href="#">more</a>
V1162	Right Front Glazing Availability	2	Closed	<a href="#">more</a>
V1163	Right Rear Glazing Availability	2	Closed	<a href="#">more</a>
V1164	Rr2 Glazing Availability	1	Fixed	<a href="#">more</a>
V1165	Right Front Glazing Damage	0	No damage	<a href="#">more</a>
V1166	Right Rear Glazing Damage	0	No damage	<a href="#">more</a>
V1167	Rr2 Glazing Damage	0	No damage	<a href="#">more</a>
V1168	Windshield Cracked	1	Yes	<a href="#">more</a>
V1169	Windshield Broken	1	Yes <a href="#">Click for Windshield Damage figure</a>	<a href="#">more</a>
V1170	Occupant Cracked/Broke Wndshld	0	No	<a href="#">more</a>
V1171	Bond Separation Extent	0	None	<a href="#">more</a>
V1172	Windshield Code	99	<a href="#">Click for Windshield Mark figure</a>	<a href="#">more</a>



V1173	Did Sun Roof/T-Roof Open	8	Not Applicable	<a href="#">more</a>
-------	--------------------------	---	----------------	----------------------

### Case Vehicle Steering Column/Rim

[Back to Top](#)

Variable Number	Variable Name	Code Value	Code Description	Other Options
V1201	Steering Wheel Rim Damage	0	None	<a href="#">more</a>
V1202	Number of Steering Wheel Spokes	3	3 spokes	<a href="#">more</a>
V1203	Steering Wheel Spoke Damage	0	None	<a href="#">more</a>
V1204	Steering Wheel Hub Damage	0	None	<a href="#">more</a>
V1205	Steering Wheel Location of Rim Damage	0	No damage	<a href="#">more</a>
V1206	Aftermarket Add-on Device	0	None	<a href="#">more</a>
V1207	Column Tilt Feature	3	Middle	<a href="#">more</a>
V1208	Column Swing-away Feature	0	Not equipped	<a href="#">more</a>
V1209	Column Telescoping Feature	0	Not equipped	<a href="#">more</a>
V1210	Wheel Energy Absorb Device	8	Not currently collected	<a href="#">more</a>
V1211	Wheel EA Device's original/damage Dimension Difference	888	Not collected	<a href="#">more</a>
V1212	Column Energy Absorb Device	88	Not collected	<a href="#">more</a>
V1213	Col EA Device's Orig/compressed (or Extruded) Length Diff	888	Not collected	<a href="#">more</a>
V1214	Shear Capsule Separation	888	Not collected	<a href="#">more</a>
V1215	Column Vertical Rotation	0	No apparent rotation	<a href="#">more</a>
V1216	Column Lateral Rotation	0	No apparent rotation	<a href="#">more</a>

### Case Vehicle Intrusion

[Back to Top](#)

Variable Number	Variable Name	Code Value	Code Description	Other Options
V1301	Was Occupant Compartment Intruded	0	No <a href="#">Click for Intrusion Worksheet figure</a> <a href="#">Click for Intrusion figure</a>	<a href="#">more</a>
V1302	Was Intrusn Catastrophic	8	Not applicable	<a href="#">more</a>
V1303	Intrusion Number #1	99	Unknown or data not collected	<a href="#">more</a>
V1304	Occupant Space Number(1)	99	Unknown or data not collected	<a href="#">more</a>

V1305	Intrud Component/obj (1)	99	Unknown or data not collected	<a href="#">more</a>
V1306	Associate Event Numb (1)	9	Unknown or data not collected	<a href="#">more</a>
V1307	Maximum Intrusion X Axis	99	Unknown or data not collected	<a href="#">more</a>
V1308	Maximum Intrusion Y Axis	99	Unknown or data not collected	<a href="#">more</a>
V1309	Maximum Intrusion Z Axis	99	Unknown or data not collected	<a href="#">more</a>
V1310	Occupant Number #1 (1)	99	Unknown or data not collected	<a href="#">more</a>
V1311	Injury Number #1 (1)	99	Contact, injury unknown or data not collected	<a href="#">more</a>
V1312	Occupant Number #2 (1)	99	Unknown or data not collected	<a href="#">more</a>
V1313	Injury Number #2 (1)	99	Contact, injury unknown or data not collected	<a href="#">more</a>
V1314	Intrusion Number #2	99	Unknown or data not collected	<a href="#">more</a>
V1315	Occupant Space Number(2)	99	Unknown or data not collected	<a href="#">more</a>
V1316	Intrud Component/obj (2)	99	Unknown or data not collected	<a href="#">more</a>
V1317	Associate Event Numb (2)	9	Unknown or data not collected	<a href="#">more</a>
V1318	Maximum Intrusion X Axis	99	Unknown or data not collected	<a href="#">more</a>
V1319	Maximum Intrusion Y Axis	99	Unknown or data not collected	<a href="#">more</a>
V1320	Maximum Intrusion Z Axis	99	Unknown or data not collected	<a href="#">more</a>
V1321	Occupant Number #1 (2)	99	Unknown or data not collected	<a href="#">more</a>
V1322	Injury Number #1 (2)	99	Contact, injury unknown or data not collected	<a href="#">more</a>
V1323	Occupant Number #2 (2)	99	Unknown or data not collected	<a href="#">more</a>
V1324	Injury Number #2 (2)	99	Contact, injury unknown or data not collected	<a href="#">more</a>
V1325	Intrusion Number #3	99	Unknown or data not collected	<a href="#">more</a>
V1326	Occupant Space Number(3)	99	Unknown or data not collected	<a href="#">more</a>
V1327	Intrud Compnent/obj (3)	99	Unknown or data not collected	<a href="#">more</a>
V1328	Associate Event Numb (3)	9	Unknown or data not collected	<a href="#">more</a>
V1329	Maximum Intrusion X Axis	99	Unknown or data not collected	<a href="#">more</a>
V1330	Maximum Intrusion Y Axis	99	Unknown or data not collected	<a href="#">more</a>
V1331	Maximum Intrusion Z Axis	99	Unknown or data not collected	<a href="#">more</a>
V1332	Occupant Number #1 (3)	99	Unknown or data not collected	<a href="#">more</a>
V1333	Injury Number #1 (3)	99	Contact, injury unknown or data not collected	<a href="#">more</a>
V1334	Occupant Number #2 (3)	99	Unknown or data not collected	<a href="#">more</a>
V1335	Injury Number #2 (3)	99	Contact, injury unknown or data not collected	<a href="#">more</a>
V1336	Intrusion Number #4	99	Unknown or data not collected	<a href="#">more</a>
V1337	Occupant Space Number(4)	99	Unknown or data not collected	<a href="#">more</a>

V1338	Intrud Component/obj (4)	99	Unknown or data not collected	<a href="#">more</a>
V1339	Associate Event Numb (4)	9	Unknown or data not collected	<a href="#">more</a>
V1340	Maximum Intrusion X Axis	99	Unknown or data not collected	<a href="#">more</a>
V1341	Maximum Intrusion Y Axis	99	Unknown or data not collected	<a href="#">more</a>
V1342	Maximum Intrusion Z Axis	99	Unknown or data not collected	<a href="#">more</a>
V1343	Occupant Number #1 (4)	99	Unknown or data not collected	<a href="#">more</a>
V1344	Injury Number #1 (4)	99	Contact, injury unknown or data not collected	<a href="#">more</a>
V1345	Occupant Number #2 (4)	99	Unknown or data not collected	<a href="#">more</a>
V1346	Injury Number #2 (4)	99	Contact, injury unknown or data not collected	<a href="#">more</a>
V1347	Intrusion Number #5	99	Unknown or data not collected	<a href="#">more</a>
V1348	Occupant Space Number(5)	99	Unknown or data not collected	<a href="#">more</a>
V1349	Intrud Component/obj (5)	99	Unknown or data not collected	<a href="#">more</a>
V1350	Associate Event Numb (5)	9	Unknown or data not collected	<a href="#">more</a>
V1351	Maximum Intrusion X Axis	99	Unknown or data not collected	<a href="#">more</a>
V1352	Maximum Intrusion Y Axis	99	Unknown or data not collected	<a href="#">more</a>
V1353	Maximum Intrusion Z Axis	99	Unknown or data not collected	<a href="#">more</a>
V1354	Occupant Number #1 (5)	99	Unknown or data not collected	<a href="#">more</a>
V1355	Injury Number #1 (5)	99	Contact, injury unknown or data not collected	<a href="#">more</a>
V1356	Occupant Number #2 (5)	99	Unknown or data not collected	<a href="#">more</a>
V1357	Injury Number #2 (5)	99	Contact, injury unknown or data not collected	<a href="#">more</a>
V1358	Intrusion Number #6	99	Unknown or data not collected	<a href="#">more</a>
V1359	Occupant Space Number(6)	99	Unknown or data not collected	<a href="#">more</a>
V1360	Intrud Component/obj (6)	99	Unknown or data not collected	<a href="#">more</a>
V1361	Associate Event Numb (6)	9	Unknown or data not collected	<a href="#">more</a>
V1362	Maximum Intrusion X Axis	99	Unknown or data not collected	<a href="#">more</a>
V1363	Maximum Intrusion Y Axis	99	Unknown or data not collected	<a href="#">more</a>
V1364	Maximum Intrusion Z Axis	99	Unknown or data not collected	<a href="#">more</a>
V1365	Occupant Number #1 (6)	99	Unknown or data not collected	<a href="#">more</a>
V1366	Injury Number #1 (6)	99	Contact, injury unknown or data not collected	<a href="#">more</a>
V1367	Occupant Number #2 (6)	99	Unknown or data not collected	<a href="#">more</a>
V1368	Injury Number #2 (6)	99	Contact, injury unknown or data not collected	<a href="#">more</a>
V1369	Intrusion Number #7	99	Unknown or data not collected	<a href="#">more</a>
V1370	Occupant Space Number(7)	99	Unknown or data not collected	<a href="#">more</a>

V1371	Intrud Component/obj (7)	99	Unknown or data not collected	<a href="#">more</a>
V1372	Associate Event Numb (7)	9	Unknown or data not collected	<a href="#">more</a>
V1373	Maximum Intrusion X Axis	99	Unknown or data not collected	<a href="#">more</a>
V1374	Maximum Intrusion Y Axis	99	Unknown or data not collected	<a href="#">more</a>
V1375	Maximum Intrusion Z Axis	99	Unknown or data not collected	<a href="#">more</a>

Driver Airbag

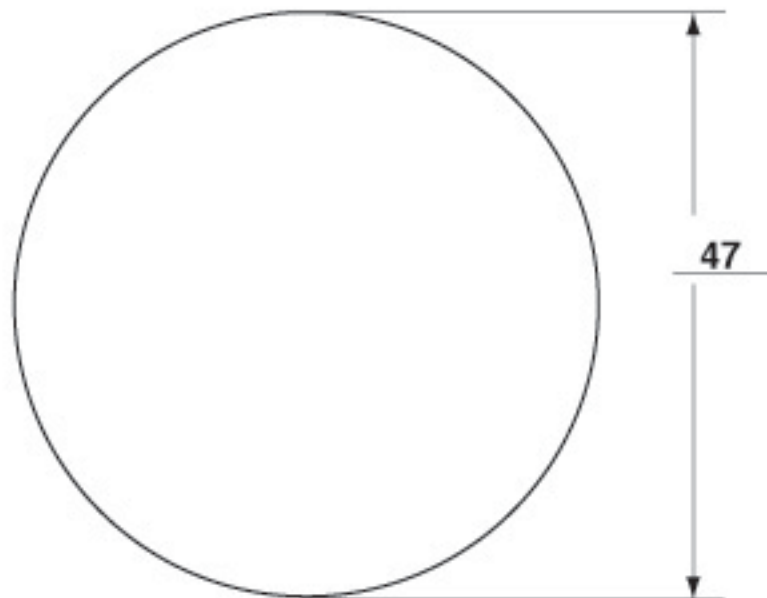

Driver Airbag Doors

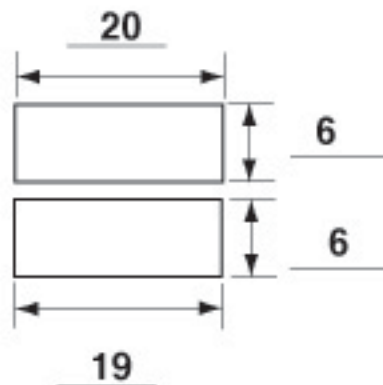

Vents:  Y  N  
if yes, how many: 2

Tethers:  Y  N  
if yes, how many: 2

11 and 1 o'clock

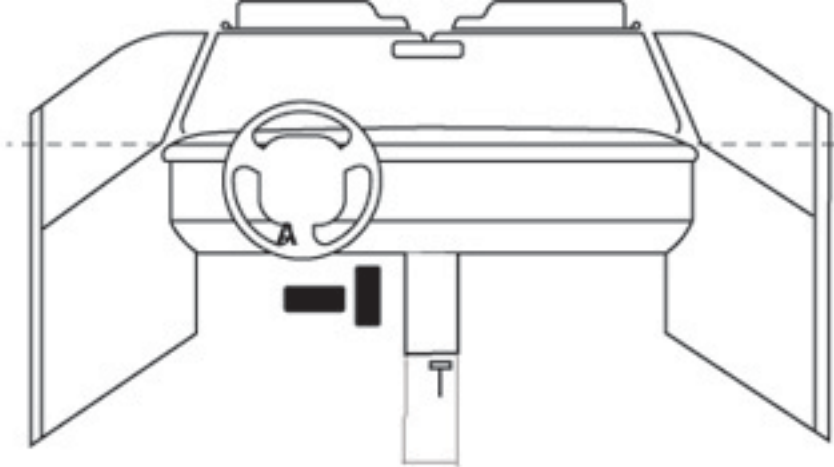

**A = knee bolster, scuffed**

1 = Definitely 2 = Probably 3 = Possible

INTRUSION IT-1

Location of Intrusion	Intruded Component	(All Measurements Are in Centimeters)			Dominant Crush Direction
		Comparison Value	–	Intruded Value = Intrusion	
	None		–	=	
			–	=	
			–	=	
			–	=	
			–	=	
			–	=	
			–	=	
			–	=	
			–	=	
			–	=	
			–	=	
			–	=	
			–	=	

OCCUPANT CONTACT WORKSHEET

Contact	Interior Component Contacted	Occupant No. if Known	Body Region if Known	Supporting Physical Evidence	Confidence Level of Contact Point
A	knee bolster	DR	LX	scuffed	1
B					
C					
D					
E					
F					
G					

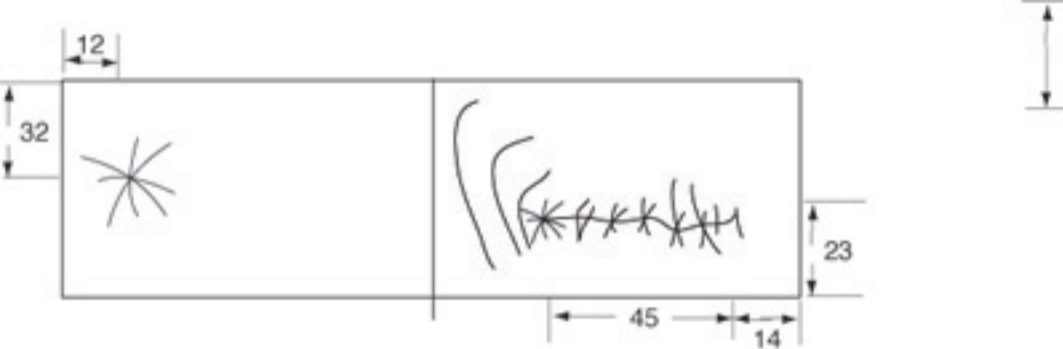

Windshield cracked on the upper left by hood contact and on the right by dash-mounted airbag flap contact



WINDSHIELD MARK ON CASE VEHICLE:

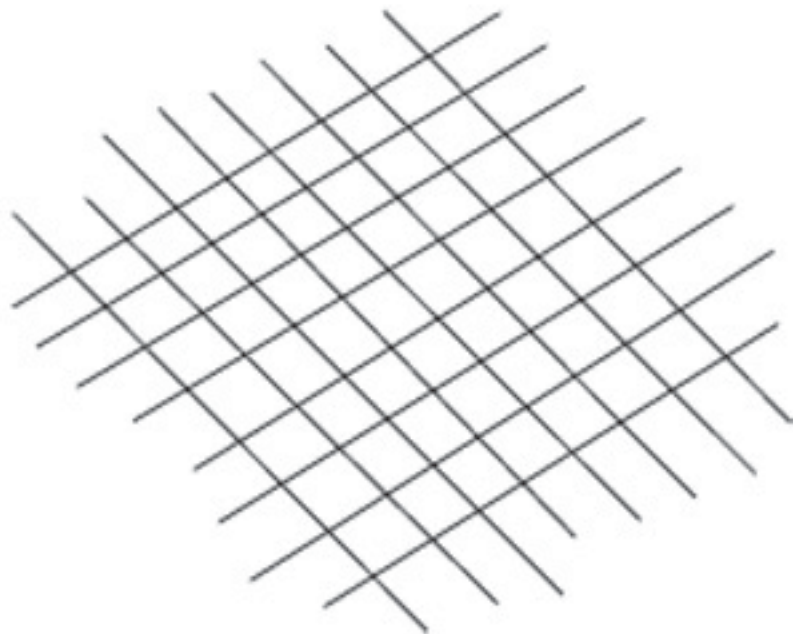

**Bumper corners shifted to left**

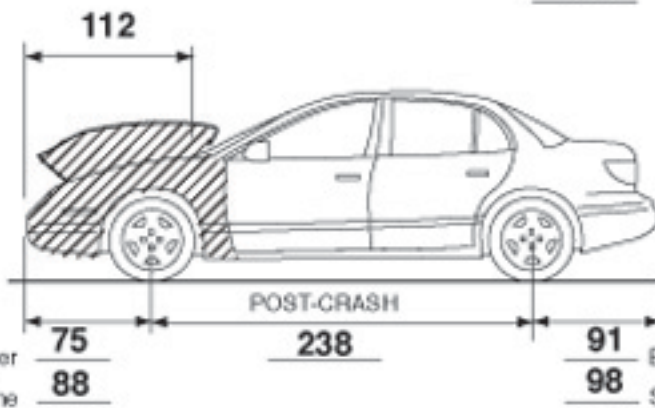
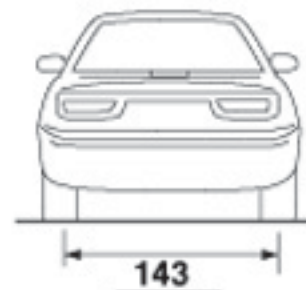
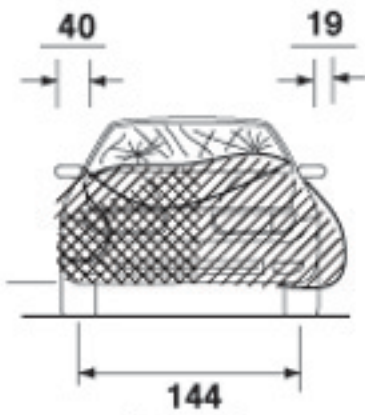

**Max. crush to center of upper radiator support**

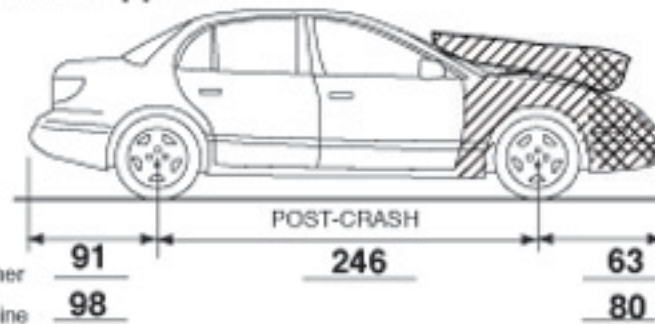

Max. crush to right bumper corner

Width of direct damage to front

MEASUREMENTS IN CENTIMETERS

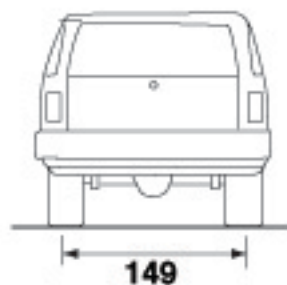
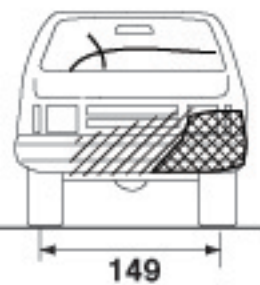

Width of direct damage to front

Max. crush to front at left bumper corner

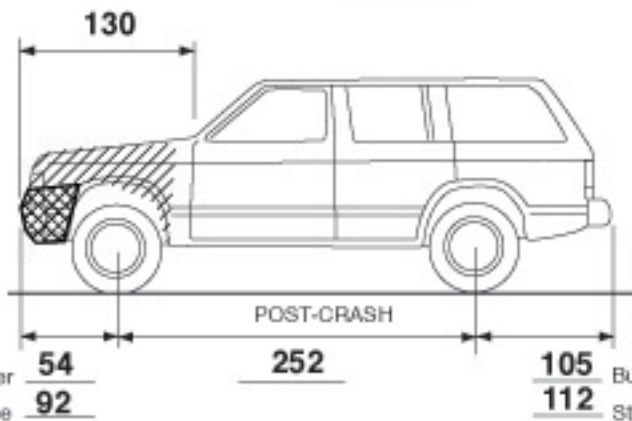

Bumper corner  
Stringline

Bumper corner  
Stringline

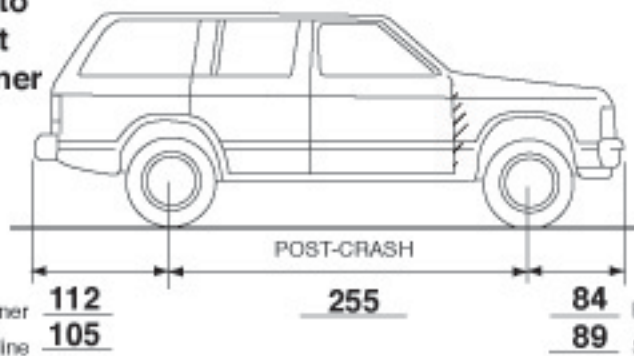

Bumper corner  
Stringline

Bumper corner  
Stringline

### Passenger Airbag

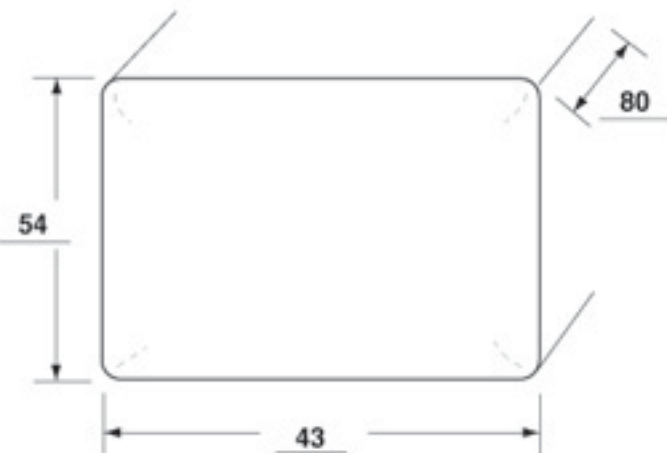

### Passenger Airbag Doors

#### Single Door

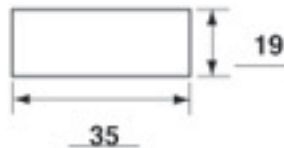

Vents:  Y  N

if yes, how many: 2

Tethers: Y  N

if yes, how many: \_\_\_\_\_

























SRS  
AIRBAG

TAPE















0824

30



YELLOW TAG

DEALER MUST REPAIR  
DAMAGE TO  
COVER

DEALER MUST REPAIR  
DAMAGE TO  
COVER

DEALER MUST REPAIR  
DAMAGE TO  
COVER





SFRS  
AIRBAG

7 8 9 10 11 12  
1 2 3 4 5  
1 FT IN  
MADE IN USA









1 FT 1 IN  
2  
3 CM 4  
5  
6  
7  
8  
9  
10  
11  
12  
13  
14  
15  
16  
17  
18  
19  
20  
21  
22

8729

MADE IN USA

COO

P.A. APPROVED TC

STUD CENTER

0 20 40 60 80

00000

1404

















































































