

Case 461 : Narrative

Case Vehicle (A): 1999 Ford
Type: Contour SE sport, 4-door sedan
Driver: 46-year-old female
CDC: 12-FCEN-3

SITUATION

[1](#) It was a clear dark night, there were no streetlights, and the east-west, multi-lane, asphalt freeway was dry and in good condition as [2](#) case vehicle (A) was traveling east at an unknown speed in the rightmost eastbound lane. [3 4](#) The driver of case vehicle (A) fell asleep and, as the road curved to the left, the vehicle drifted to the right and [3 4](#) exited the south edge of the road. [5 6 7 8](#) The vehicle traveled east about 175 meters (577 feet) through the grassy roadside and [9 10](#) struck an 18-cm diameter tree with the center of the front end. Case vehicle (A) was towed due to damage. The police accident report indicates B-level injuries for the female driver and only occupant of case vehicle (A), who was transported by ambulance to a hospital, where she was admitted and treated for 18 days.

GENERAL VEHICLE DAMAGE AND ESTIMATED CRASH SEVERITIES

[11](#) Damage to case vehicle (A) was severe. [12](#) Direct damage was confined to a narrow area between the front headlights. The maximum crush was 71 cm and it occurred at the center of the front bumper.

Using the WinSMASH crash-reconstruction program and a crush profile measured for [13 14 15](#) case vehicle (A) at the level of the bumper, the following impact severity was estimated:

		Estimated Velocity Change - kph (mph)		
Vehicle	Variable	Total	Longitudinal	Latitudinal
Case vehicle (A)	delta V	44 (27)	-44 (-27)	0 (0)

DESCRIPTION OF DAMAGE TO CASE VEHICLE (A)

Exterior

In the front, [16](#) the center of the bumper and center front of the hood were crushed rearward past the plane of the radiator supports, and the center of the hood was buckled up. The hood latch was damaged and jammed closed, [17](#) the left hood hinge was bent to the right, and [18](#) the right hood hinge was bent to the left. [19](#) The rear edge of the hood was elevated and it contacted and deformed the cowl, which caused cracks along the bottom of the windshield. [20](#) The lower-right section of the windshield was also cracked from contact by the deploying dash-mounted airbag.

On the left side, [21](#) the front section of the fender and the front wheel were displaced rearward, which

reduced the left wheelbase by 15 cm. [22](#) There was tree bark embedded in the bead of the left-front wheel but the tire was still inflated. [23](#) The center section of the fender was deflected out and the rear section was buckled in. [24](#) The driver door was jammed closed and had been pried open by rescue personnel, and [25](#) [26](#) the left-rear door was closed and operational. The windows of both left-side doors had been broken out by rescue personnel but the opera window in the left-rear door was intact.

[27](#) There was no damage to the rear of the vehicle.

[28](#) On the right side, the fender was displaced to the left and the front wheel was crushed rearward, which reduced the right wheelbase by 6 cm. [29](#) The lower part of the front wheel was displaced in, [30](#) [31](#) both right-side doors were closed and operational, and all the right-side glazing was intact.

Interior

This vehicle was equipped with steering-wheel and dash-mounted frontal-impact airbags, and [32](#) [33](#) both deployed during the frontal impact with the tree. In the driver area, there was no damage to the steering-wheel airbag but the fabric was stained with an unknown substance. [34](#) [35](#) [36](#) [37](#) The upper section of the airbag module cover was scuffed but there was no damage to the lower cover. [38](#) [39](#) The upper half of the steering-wheel rim was bent forward and [40](#) all four of the steering-wheel spokes were slightly deformed. The steering column was displaced up but there was no lateral displacement. [41](#) The plastic trim was displaced from the upper section of the B-pillar and [42](#) the rear section of the driver door panel was detached. [43](#) The control knobs and [44](#) the left-mid section of the instrument panel were displaced rearward, and the upper section of the instrument panel was deflected up. [45](#) The driver knee bolster was dented and scuffed to the left of the steering column and it was scuffed and cracked to the right of the steering column. [46](#) The underside of the steering column was scuffed, [47](#) the gas pedal was broken off, the brake pedal was deflected rearward and to the left, and the toepan was buckled rearward. [48](#) The driver seatback had been rotated rearward by rescue personnel to facilitate providing aid to the driver, but [49](#) there was no other damage in the driver seating area.

In the center-front area, [50](#) [51](#) the rearview mirror was separated from its mount on the windshield and the mirror was cracked. [52](#) The upper section of the center stack was deflected to the right and displaced rearward. There was no other damage in the center-front area.

In the right-front passenger area, [53](#) [54](#) [55](#) there was no damage to the dash-mounted airbag [56](#) [57](#) but the module cover was cracked from contact with the windshield during airbag deployment. [58](#) The glove-compartment door would not close due to deformation of the dashboard and the toepan was displaced rearward. There was no other damage in the right-front seating area.

The following intrusions were noted and measured:

Location	Component	Distance (cm)	Direction
driver	toepan 59	34	to rear
	steering column 60	8	to rear
	instrument panel 61	3	to rear
center front	center stack 62	16	to rear
right front	toepan 63	20	to rear

OCCUPANT KINEMATICS AND INJURIES

64 The 153-cm, 98-kg (5-ft, 216-lb) 46-year-old female driver was using the three-point belt 65 and the steering-wheel airbag deployed. 66 67 68 Belt use is indicated by the shoulder belt being crumpled and jammed in the forward section of the D-ring, and webbing loading marks on the D-ring and the continuous loop of the sliding latch plate.

During the frontal impact, the driver moved forward relative to the vehicle interior into the belt restraints, the airbag, and the knee bolster. She sustained several thoracic injuries, including fractures to the anterior aspects of right ribs 1 and 2 and left ribs 4 through 7, fractures to the lateral aspects of right ribs 3 through 7, a dislocation of the right clavicle at the sternoclavicular joint, a fracture to the right side of the manubrium (upper sternum), and right pleura contusion with right superior mediastinal hematoma, probably from a combination of shoulder belt and close-proximity loading by the deploying airbag.

She sustained a comminuted transverse fracture to the distal right ulna, probably due to loading the steering-wheel rim, or possibly due to close-proximity loading by the deploying airbag. She sustained displaced comminuted fractures of the right and left tibial pylon, a displaced comminuted fracture of the left distal fibula, a displaced comminuted transverse fracture to the right distal fibula, displaced bimalleolar fractures of the right medial and lateral malleolus, a displaced fracture of the left talus, a comminuted fracture to the left calcaneus, and a fracture to the left medial malleolus, probably from contact of her feet with the toepan.

The following table and attached drawing 69 summarize the injuries for the restrained driver of case vehicle (A).

Occupant: Driver	Age: 46 years	Gender: Female		
Restraints: 3-point belt; steering-wheel airbag	Stature: 153 cm (5 ft)	Mass: 98 kg (216 lb)		
Injury Description	A.I.S.	Injury Source		
		Definite	Probable	Possible
—	—			
Fractures, anterior aspects of right ribs 1 and 2 and left ribs 4 through 7, and lateral aspects of right ribs 3 through 7	4	—	Shoulder belt and airbag	—
Dislocation of right clavicle at sternoclavicular joint	2	—	Shoulder belt and airbag	—
Right pleura contusion with a superior right mediastinal hematoma	2	—	Shoulder belt and airbag	—
Fracture, right manubrium of the sternum	2	—	Shoulder belt and airbag	—
Comminuted transverse fracture, right distal ulna	3	—	Steering-wheel rim	Airbag
Displaced comminuted fracture, left tibial pylon	3	—	Toepan	—
Displaced comminuted fracture, right tibial pylon	3	—	Toepan	—

Displaced bimalleolar fractures, right medial malleolus and right lateral malleolus	3	—	Toepan	—
Displaced comminuted fracture, left distal fibula	2	—	Toepan	—
Displaced comminuted transverse fracture, right distal fibula	2	—	Toepan	—
Fracture, left medial malleolus	2	—	Toepan	—
Comminuted fracture, left calcaneous	2	—	Toepan	—
Displaced fracture, left talus	2	—	Toepan	—
Maximum A.I.S. Level	4	—	—	—
Injury Severity Score	25	—	—	—

CASE NO.: 461

CASE VEHICLE: 1999 Ford

TYPE: Contour SE, 4-door sedan

OCCUPANT: Driver: 46-year-old female

STATURE: 153 cm (5 ft) MASS: 98 kg (216 lb)

RESTRAINTS: 3-point belt; steering-wheel airbag

SEVERITY: MAIS - 4 : ISS - 25

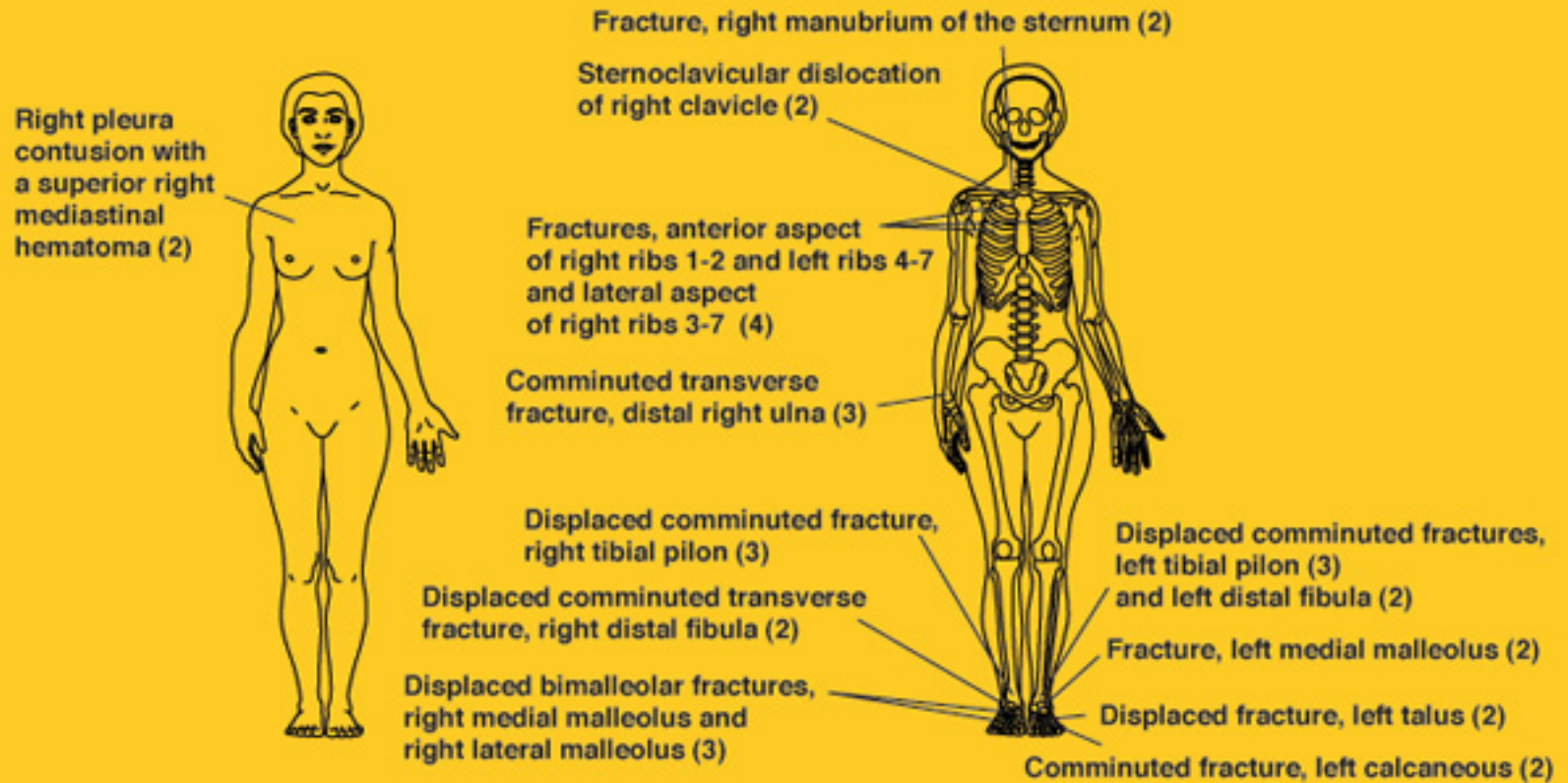

Case No.: **461**
Case Veh. (A): **1999 Ford**
Type: **Contour SE, 4-door sedan**
Driver: **46-year-old female**

Light Conditions: **Dark-Unlighted**
Weather: **Clear**
Road Surface: **Dry**
Road Construction: **Asphalt**

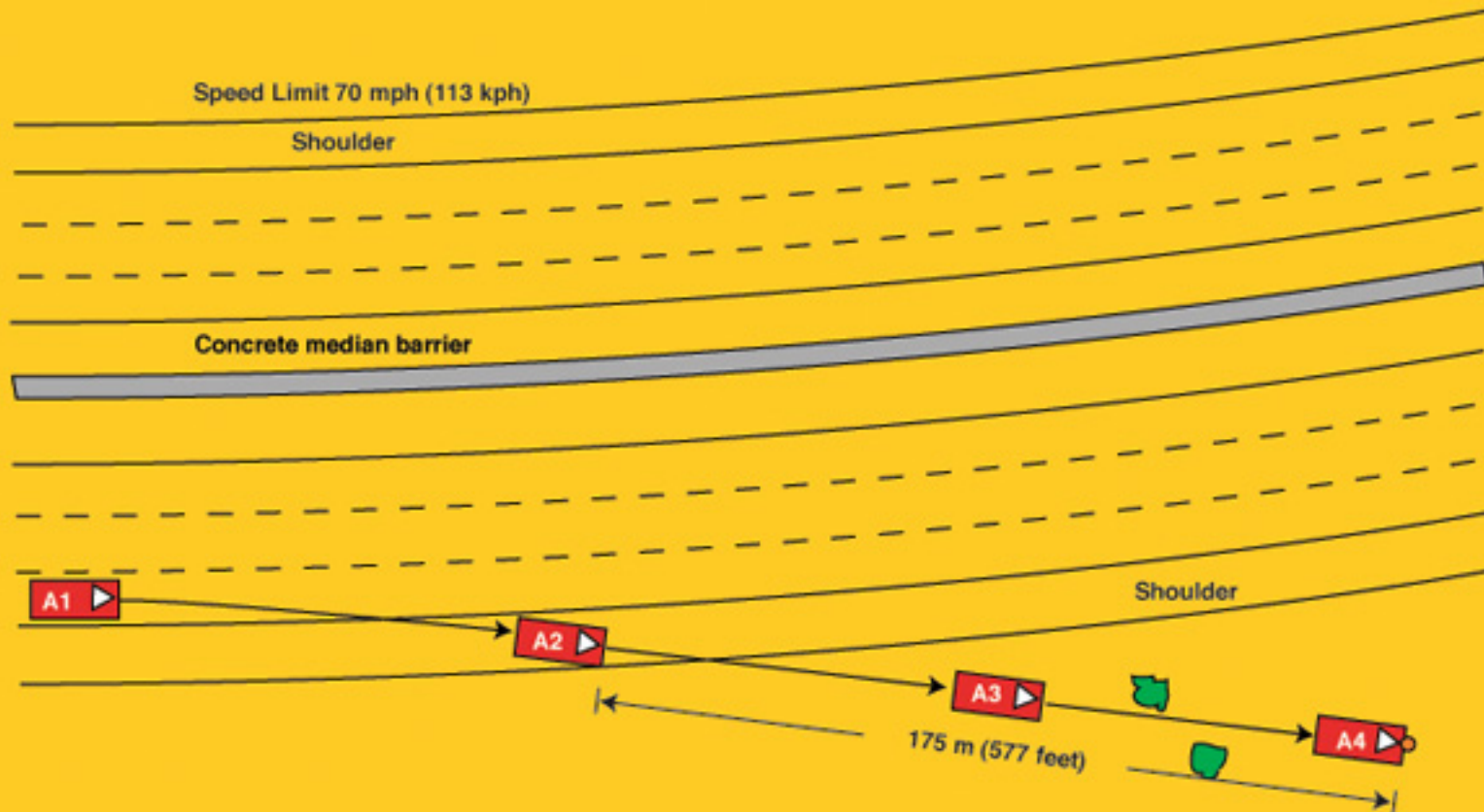

461: Vehicle Report

Click on Section Name to jump directly to that Section —

- [General Information](#)
 - [Other Vehicle](#)
 - [Case Vehicle General](#)
 - [Case Vehicle Damage Description](#)
 - [Crash Reconstruction](#)
 - [Case Vehicle Tires & Rims](#)
 - [Case Vehicle Fuel Tank](#)
 - [Case Vehicle Fuel Leakage](#)
 - [Case Vehicle Fire](#)
 - [Case Vehicle Exterior](#)
 - [Case Vehicle Steering Column/Rim](#)
 - [Case Vehicle Intrusion](#)
 - [Case Vehicle Airbag\(s\)](#)
 - [Case Vehicle Interior](#)
 - [Case Vehicle Seats](#)
 - [Case Vehicle Side Airbag\(s\)](#)
 - [EDR -- Event Data Recorder](#)
-

General Information

[Back to Top](#)

Variable Number	Variable Name	Code Value	Code Description	Other Options
V0204	Collision Hour	2155	Time of day (24 hour clock)	more
V0205	State Fips Code	26	Michigan	more
V0206	Urban/rural Area	2	Rural	more
V0207	Limited Access Highway	1	Yes	more
V0208	Road Total Lanes	5	Divided, 4 lanes or more	more
V0209	Intersect Road Total Lanes	8	Not applicable	more
V0210	Trafficway Flow	2	Divided trafficway - median strip with positive	more
V0211	Road Surface Type	1	Asphalt	more
V0212	Road Defects	0	No	more
V0213	Construction Zone	0	No	more
	Road Alignment Vertical			

V0214	Plane	1	Level	more
V0215	Road Alignment Horizontal Plane	2	Curve	more
V0216	Surface Covering	10	Dry	more
V0217	Visibility Limitation	0	None	more
V0218	Visibility Obstruction	0	None	more
V0219	Speed Limit	8	106+ km/h .. 65+ mph	more
V0220	Precipitation Type	0	None	more
V0221	Precipitation Rate	8	Not applicable	more
V0222	Temperature	9	Unknown	more
V0223	Crosswind	0	None	more
V0224	Light Conditions	5	Dark, unlighted	more
V0225	Mechanical Malfunction Mention	0	No	more
V0226	Case Vehicle And Object	3	Yes, non-fixed object off-road	more
V0227	Case Vehicle Rollover	0	No	more
V0228	Rollover Location	0	No rollover	more
V0229	Roll Direction	0	No rollover	more
V0230	Rollover Initiation Type	0	No rollover	more
V0231	Rollover Number Of Turns	0	No rollover	more
V0232	Case Vehicle Preimpact Braking	0	No	more
V0233	Case Vehicle Preimpact Stability	1	Case vehicle tracking before impact	more
V0234	Case Vehicle Ran Off Roadway	1	Yes	more
V0235	Moving Case Vehicle Contacted Moving Vehicle	0	No	more
V0236	Case Vehicle Contacted Stopped Vehicle	0	No	more
V0237	Stopped Case Vehicle Contacted Vehicle	0	No	more
V0238	Total Vehicles Hit By Case Vehicle	0	0 vehicles	more
V0239	Any Fire In Crash?	0	No	more
V0240	Maximum Police Severity-acc	2	B - Non-Incapacitating Injury	more
V0241	Driver Alcohol Involvmnt	0	Had not been drinking	more
V0242	Driver Alcohol BAC (Case Vehicle)	80	No test	more
V0243	Driver Impairment Mention	0	No	more

V0244	Driver Distraction	11	Sleepy or fell asleep	more
V0245	Driver Drug Involvement	0	None	more
V0246	Driver Drug Type	0	No drug use	more
V0247	Driven/towed From Scene	2	Towed Due to Damage	more

Other Vehicle

[Back to Top](#)

Variable Number	Variable Name	Code Value	Code Description	Other Options
V0301	Other Vehicle VIN	0 xxxxxxx	Click for Contacted Vehicle figure	more
V0302	Other Vehicle Manufacturer/Body Code	99898	—	—
V0303	Other Vehicle Manufacturer	998	Unknown Other Vehicle	more
V0304	Other Vehicle Body Code	98	No Other Vehicle	more
V0305	Other Vehicle Make/model	0000	No other vehicle	more
V0306	Other Vehicle Model Year	0000	No Other Vehicle	more
V0307	Other Vehicle Mass	000000 kg	No Other Vehicle	more
V0308	Other Vehicle Number	8	No other vehicle	more
V0309	Other Vehicle Number of Occupants	98	No Other Vehicle	more
V0310	Other Vehicle Traveling Speed	990	No Other Vehicle	more
V0311	Highest Police Injury Severity	8	No Other Vehicle	more
V0312	Other Vehicle Type	98	No Other Vehicle	more
V0313	Other Vehicle Wheelbase in Centimeters	998	No Other Vehicle	more
V0314	Other Vehicle Average Track Width	998	No Other Vehicle	more
V0315	Other Vehicle Overall Length	998	No Other Vehicle	more
V0316	Other Vehicle Overall Width (OAW)	998	No Other Vehicle	more
V0317	Other Vehicle Front Overhang	998	No Other Vehicle	more
V0318	Other Vehicle Rear Overhang	998	No Other Vehicle	more
V0319	Other Vehicle Undeformed End Width (UEW)	998	No Other Vehicle	more
V0320	Other Vehicle Engine Displacement	0.0 l	No Other Vehicle	more
	Other Vehicle Engine:			

V0321	Number of Cylinders	98	No Other Vehicle	more
V0322	Other Vehicle Direct Damage Length (DDL)	998	No Other Vehicle	more
V0323	Other Vehicle Front-End Overlap	99	Missing or Not applicable	more
V0324	Other Vehicle - Vehicle Overlap	99	Missing or Not applicable	more

Case Vehicle General

[Back to Top](#)

Variable Number	Variable Name	Code Value	Code Description	Other Options
V0401	VIN	1FAFP66L8XXXXXXXX	Click for Case Vehicle figure	more
V0402	Manufacturer/Body Code	12128	—	—
V0403	Vehicle Manufacturer	121	Ford	more
V0404	Vehicle Body Code	28	Intermediate 105-109.9 in. wb.	more
V0405	Make/model Code	0208	Contour	more
V0406	Model Year	1999	Model year	more
V0407	Vehicle Mass	001337 kg	Mass (Kg)	more
V0408	Odometer Reading	047043	—	—
V0409	Number of Occupants	01	1 occupant	more
V0410	Traveling Speed	999	Unknown	more
V0411	Body Type	14	4-door sedan	more
V0412	Stolen Vehicle	8	Not currently collected	more
V0413	Body Structure	2	Unitized	more
V0414	Transmission Type	1	Automatic	more
V0415	Transmission Lever Location	2	Console	more
V0416	Steering	1	Power	more
V0417	Brakes	1	Power	more
V0418	Brake Type	2	Disc - front wheels	more
V0419	Adjustable Pedals?	0	No	more
V0420	Brake Anti-lock Device	0	None installed	more
V0421	Air Conditioning in Vehicle	8	Not currently collected	more
V0422	Drive Type	2	Front wheel	more
V0423	Dual Rear Wheels	0	No	more
V0424	Original Restraint System Type	3	Air bag	more

V0425	Equipped With Roll Bar	0	No	more
V0426	Roof Type	1	Solid	more
V0427	Case Vehicle Wheelbase in Centimeters	270 cm	Actual Wheelbase	more
V0428	Anti-lacerative Glass	8	Not Collected	more
V0429	Case Vehicle average track Width	150 cm	actual measurement (cm)	more
V0430	Case Vehicle Overall Length	469 cm	actual measurement (cm)	more
V0431	Case Vehicle Overall Width (OAW)	176	actual measurement (cm)	more
V0432	Case Vehicle Front Overhang	095 cm	actual measurement (cm)	more
V0433	Case Vehicle Rear Overhang	104 cm	actual measurement (cm)	more
V0434	Case Vehicle Undeformed End Width (UEW)	146 cm	actual measurement (cm)	more
V0435	Case Vehicle Engine Displacement	2.5 l	Liters	more
V0436	Case Vehicle Engine: Number of Cylinders	06	number of cylinders	more
V0437	Case Vehicle Direct Damage Length (DDL)	999	Unknown	more
V0438	Case Vehicle Front-end Overlap	99	Missing or Not applicable	more
V0439	Case Vehicle - Vehicle Overlap	99	Missing or Not applicable	more

Case Vehicle Damage Description

[Back to Top](#)

Variable Number	Variable Name	Code Value	Code Description	Other Options
V0501	Maximum Sheet Metal Crush - Front	071 cm	Depth of Crush (cm)	more
V0502	Maximum Sheet Metal Crush - Right Side	000 cm	No Crush (or less than 1 cm.)	more
V0503	Maximum Sheet Metal Crush - Rear	000 cm	No Crush (or less than 1 cm.)	more
V0504	Maximum Sheet Metal Crush - Left Side	000 cm	No Crush (or less than 1 cm.)	more

V0505	Maximum Sheet Metal Crush - Roof	000 cm	No Crush (or less than 1 cm.)	more
V0506	Maximum Sheet Metal Crush - Other	000 cm	No Crush (or less than 1 cm.)	more
V0507	Seq In Chronological Ord	1	Yes	more
V0508	Event 1 -impact Location	4	Outside Roadside right-of-way	more
V0509	Event 1 -Impact Configuration	17	FRONT of case veh - object	more
V0510	Event 1 -Object/Vehicle Contactd	28	Intermediate 105-109.9 in. wb.	more
V0511	Event 2 -impact Location	8	No 2nd event	more
V0512	Event 2 -Impact Configuration	88	No 2nd event	more
V0513	Event 2 -Object/Vehicle Contactd	00	No object/vehicle contacted	more
V0514	Event 3 -impact Location	8	No 3rd event	more
V0515	Event 3 -Impact Configuration	88	No 3rd event	more
V0516	Event 3 -Object/Vehicle Contactd	00	No object/vehicle contacted	more
V0517	Event 4 -impact Location	8	No 4th event	more
V0518	Event 4 -Impact Configuration	88	No 4th event	more
V0519	Event 4 -Object/Vehicle Contactd	00	No object/vehicle contacted	more
V0520	Event 5 -impact Location	8	No 5th event	more
V0521	Event 5 -Impact Configuration	88	No 5th event	more
V0522	Event 5 -Object/Vehicle Contactd	00	No object/vehicle contacted	more
V0523	Event 6 -impact Location	8	No 6th event	more
V0524	Event 6 -Impact Configuration	88	No 6th event	more
V0525	Event 6 -Object/Vehicle Contactd	00	No object/vehicle contacted	more
V0526	Event 7 -impact Location	8	No 7th event	more
V0527	Event 7 -Impact Configuration	88	No 7th event	more
V0528	Event 7 -Object/Vehicle Contactd	00	No object/vehicle contacted	more
V0529	Primary CDC Case Vehicle - event Number	1	Event 1	more

V0530	Primary CDC Case Vehicle - Impact Speed (kph)	999	Unknown	more
V0531	Primary CDC Case Vehicle-estimatr	1	Investigator	more
V0532	Primary CDC Case Vehicle - Crush (CM)	071	Crush measurements in cm	more
V0533	Primary CDC Case Vehicle-clock #1	12	12 o'clock	more
V0534	Primary CDC Case Vehicle-Letter 1 #1	06	F - Front	more
V0535	Primary CDC Case Vehicle-Letter 2 #1	03	C - Center (Front or Rear)	more
V0536	Primary CDC Case Vehicle-Letter 3 #1	05	E - Everything below belt line	more
V0537	Primary CDC Case Vehicle-Letter 4 #1	14	N - Narrow impact area	more
V0538	Primary CDC Case Vehicle Extent #1	03	Extent 3	more
V0539	Primary CDC - Contacted Vehicles Assoc CDC - CDC #1	12FCEN3	—	—
V0540	Primary CDC Case Vehicle-clock #2	98	Not Applicable	more
V0541	Primary CDC Case Vehicle-Letter 1 #2	00	Missing Data/Not applicable	more
V0542	Primary CDC Case Vehicle-Letter 2 #2	00	Missing Data/Not applicable	more
V0543	Primary CDC Case Vehicle-Letter 3 #2	00	Missing Data/Not applicable	more
V0544	Primary CDC Case Vehicle-Letter 4 #2	00	Missing Data/Not applicable	more
V0545	Primary CDC Case Vehicle Extent #2	00	Missing Data/Not applicable	more
V0546	Primary CDC - Case Vehicle Assoc CDC - CDC #2	9800000	—	—
V0547	Primary CDC Contacted Vehicle - Impact Speed (kph)	998	Not Applicable	more
V0548	Primary CDC Contacted Vehicle-estimator	8	Not applicable (no vehicle/no impact)	more
V0549	Primary CDC Contacted Vehicle - Crush (CM)	998	Not Applicable	more
V0550	Primary CDC Contacted Vehicle-clock #1	98	Not Applicable	more

V0551	Primary CDC Contacted Vehicle-Letter 1 #1	00	Missing Data/Not applicable	more
V0552	Primary CDC Contacted Vehicle-Letter 2 #1	00	Missing Data/Not applicable	more
V0553	Primary CDC Contacted Vehicle-Letter 3 #1	00	Missing Data/Not applicable	more
V0554	Primary CDC Contacted Vehicle-Letter 4 #1	00	Missing Data/Not applicable	more
V0555	Primary CDC Contacted Vehicle Extent #1	00	Missing Data/Not applicable	more
V0556	primary CDC - Contacted Vehicles Assoc CDC - CDC #1	9800000	—	—
V0557	Primary CDC Contacted Vehicle-clock #2	98	Not Applicable	more
V0558	Primary CDC Contacted Vehicle-Letter 1 #2	00	Missing Data/Not applicable	more
V0559	Primary CDC Contacted Vehicle-Letter 2 #2	00	Missing Data/Not applicable	more
V0560	Primary CDC Contacted Vehicle-Letter 3 #2	00	Missing Data/Not applicable	more
V0561	Primary CDC Contacted Vehicle-Letter 4 #2	00	Missing Data/Not applicable	more
V0562	Primary CDC Contacted Vehicle Extent #2	00	Missing Data/Not applicable	more
V0563	Primary CDC - Contacted Vehicles Assoc CDC - CDC #2	9800000	—	—
V0564	Secondary CDC Case Vehicle-event No	8	Not applicable	more
V0565	Secondary CDC Case Vehicle - Impact Speed (kph)	998	Not Applicable	more
V0566	Secondary CDC Case Vehicle-estimator	8	Not applicable (no vehicle/no impact)	more
V0567	Secondary CDC Case Vehicle - Crush (CM)	998	Not Applicable	more
V0568	Secondary CDC Case Vehicle-clock #1	98	Not Applicable	more
V0569	Secondary CDC Case Vehicle-Letter 1 #1	00	Missing Data/Not applicable	more
V0570	Secondary CDC Case Vehicle-Letter 2 #1	00	Missing Data/Not applicable	more
V0571	Secondary CDC Case Vehicle-Letter 3 #1	00	Missing Data/Not applicable	more

V0572	Secondary CDC Case Vehicle-Letter 4 #1	00	Missing Data/Not applicable	more
V0573	Secondary CDC Case Vehicle Extent #1	00	Missing Data/Not applicable	more
V0574	Secondary CDC - Case Vehicle Assoc CDC - CDC #1	9800000	—	—
V0575	Secondary CDC Case Vehicle-clock #2	98	Not Applicable	more
V0576	Secondary CDC Case Vehicle-Letter 1 #2	00	Missing Data/Not applicable	more
V0577	Secondary CDC Case Vehicle-Letter 2 #2	00	Missing Data/Not applicable	more
V0578	Secondary CDC Case Vehicle-Letter 3 #2	00	Missing Data/Not applicable	more
V0579	Secondary CDC Case Vehicle-Letter 4 #2	00	Missing Data/Not applicable	more
V0580	Secondary CDC Case Vehicle Extent #2	00	Missing Data/Not applicable	more
V0581	Secondary CDC - Case Vehicle Assoc CDC - CDC #2	9800000	—	—
V0582	Secondary CDC Contacted Vehicle - Impact Speed (kph)	998	Not Applicable	more
V0583	Secondary CDC Contacted Vehicle-estimator	8	Not applicable (no vehicle/no impact)	more
V0584	Secondary CDC Contacted Vehicle - Crush (CM)	998	Not Applicable	more
V0585	Secondary CDC Contacted Vehicle-clock #1	98	Not Applicable	more
V0586	Secondary CDC Contacted Vehicle-Letter 1 #1	00	Missing Data/Not applicable	more
V0587	Secondary CDC Contacted Vehicle-Letter 2 #1	00	Missing Data/Not applicable	more
V0588	Secondary CDC Contacted Vehicle-Letter 3 #1	00	Missing Data/Not applicable	more
V0589	Secondary CDC Contacted Vehicle-Letter 4 #1	00	Missing Data/Not applicable	more
V0590	Secondary CDC Contacted Vehicle Extent #1	00	Missing Data/Not applicable	more
V0591	Secondary CDC - Contacted Vehicle Assoc CDC - CDC #1	9800000	—	—
	Secondary CDC Contacted			

V0592	Vehicle-clock #2	98	Not Applicable	more
V0593	Secondary CDC Contacted Vehicle-Letter 1 #2	00	Missing Data/Not applicable	more
V0594	Secondary CDC Contacted Vehicle-Letter 2 #2	00	Missing Data/Not applicable	more
V0595	Secondary CDC Contacted Vehicle-Letter 3 #2	00	Missing Data/Not applicable	more
V0596	Secondary CDC Contacted Vehicle-Letter 4 #2	00	Missing Data/Not applicable	more
V0597	Secondary CDC Contacted Vehicle Extent #2	00	Missing Data/Not applicable	more
V0598	Secondary CDC - Contacted Vehicle Assoc CDC - CDC #2	9800000	—	—

Crash Reconstruction

[Back to Top](#)

Variable Number	Variable Name	Code Value	Code Description	Other Options
V0601	Primary Delta-V Case Vehicle-event #	1	Event number 1	more
V0602	Primary Delta V Case Vehicle - Total Delta V	888	Not Applicable	more
V0603	Primary delta-V Case Vehicle -LONGITUD	8888	—	—
V0604	Primary delta-V Case Vehicle-Lateral	8888	—	—
V0605	Primary Delta V Case Vehicle - Energy Dissipated by Crush (k	8888	—	—
V0606	Primary Delta-V Case Vehicle-Reconstruction	09	Yielding fixed object	more
V0607	Primary Delta-V Case Vehicle- Mode	5	Not reconstructed	more
V0608	Primary Delta V Contacted Vehicle - Total Delta V	888	Not Applicable	more
V0609	Primary delta-V Contacted Vehicle-LONGITUD	8888	—	—
V0610	Primary delta-V Contacted Vehicle-Lateral	8888	—	—
V0611	Primary delta-V Contacted Vehicle - Energy Dissipated by Cru	8888	—	—

V0612	Secondary Delta-V Case Vehicle-event #	8	Not applicable	more
V0613	Secondary Delta V Case Vehicle - Total Delta V	888	Not applicable	more
V0614	Secondarydelta-V Case Vehicle -LONGITUD	8888	—	—
V0615	Secondary delta-V Case Vehicle-Lateral	8888	—	—
V0616	Secondary delta-V Case Vehicle - Energy Dissipated by Crush	8888	—	—
V0617	Secondary Delta-V Case Vehicle-Reconstruction	88	Not applicable	more
V0618	Secondary Delta-V Case Vehicle- Mode	8	Not applicable	more
V0619	Secondary Delta V Contacted Vehicle - Total Delta V	888	Not applicable	more
V0620	Secondary delta-V Contacted Vehicle-LONGITUD	8888	—	—
V0621	Secondary delta-V Contacted Vehicle-Lateral	8888	—	—
V0622	Secondary delta-V Contacted Vehicle - Energy Dissipated By C	8888	—	—
V0623	Primary EBS Case Vehicle-event #	1	Event number 1	more
V0624	Primary EBS Case Vehicle - Total EBS	044 kph	kph	more
V0625	Primary EBS Case Vehicle - LONGITUD	-044	—	—
V0626	Primary EBS Case Vehicle-Lateral	0000	—	—
V0627	Primary EBS Case Vehicle - Energy Dissipated by Crush (kj)	0086	—	—
V0628	Primary EBS Case Vehicle-Reconstruction	22	Reconstructed, moderate confidence level	more
V0629	Primary EBS Case Vehicle-Mode	2	CDC & detailed damage	more
V0630	Primary EBS Contacted Vehicle - Total EBS	888	Not Applicable	more
V0631	Primary EBS Contacted Vehicle-LONGITUD	8888	—	—
	Primary EBS Contacted			

V0632	Vehicle-Lateral	8888	—	—
V0633	Primary EBS Contact Vehicle - Energy Dissipated by Crush (kj)	8888	—	—
V0634	Secondary EBS Case Vehicle-event #	8	Not applicable	more
V0635	Secondary EBS Case Vehicle - Total EBS	888	Not Applicable	more
V0636	Secondary EBS Case Vehicle -LONGITUD	8888	—	—
V0637	Secondary EBS Case Vehicle-Lateral	8888	—	—
V0638	Secondary EBS Case Vehicle - Energy Dissipated by Crush (kj)	8888	—	—
V0639	Secondary EBS Case Vehicle-Reconstruction	88	Not applicable	more
V0640	Secondary EBS Case Vehicle- Mode	8	Not applicable	more
V0641	Secondary EBS Contacted Vehicle - Total EBS	888	Not Applicable	more
V0642	Secondary EBS Contacted Vehicle-LONGITUD	8888	—	—
V0643	Secondary EBS Contacted Vehicle-Lateral	8888	—	—
V0644	Secondary EBS Contact Vehicle - Energy Dissipated by Crush (8888	—	—
V0645	Specific Event # Case(1)	1	Event number 1	more
V0646	Plane of Impact Case Vehicle (1)	1	Bumper	more
V0647	Direct Damage Length (DDL) - Case Vehicle (1)	018 cm	cm	more
V0648	Direct Damage Maximum Crush - Case Vehicle (1)	071 cm	cm	more
V0649	Direct and Induced Damage Length in CM	084 cm	cm	more
V0650	Field C1 - Case Vehicle (1)	015 cm	cm	more
V0651	Field C2 - Case Vehicle (1)	028 cm	cm	more
V0652	Field C3 - Case Vehicle (1)	045 cm	cm	more
V0653	Field C4 - Case Vehicle (1)	071 cm	cm	more
V0654	Field C5 - Case Vehicle (1)	019 cm	cm	more
V0655	Field C6 - Case Vehicle (1)	000 cm	No Crush	more

V0656	Direct Damage D Value = The Center of Direct Damage Offset t	+000 cm	Offset (cm)	more
V0657	Specific Event # Case(2)	1	Event number 1	more
V0658	Plane of Impact Case Vehicle (2)	1	Bumper	more
V0659	Direct Damage Length (DDL) - Case Vehicle (2)	018 cm	cm	more
V0660	Direct Damage MaximumCrush - Case Vehicle (2)	071 cm	cm	more
V0661	Direct and Induced Damage Length in CM	084 cm	cm	more
V0662	Field C1 - Case Vehicle (2)	015 cm	cm	more
V0663	Field C2 - Case Vehicle (2)	028 cm	cm	more
V0664	Field C3 - Case Vehicle (2)	045 cm	cm	more
V0665	Field C4 - Case Vehicle (2)	071 cm	cm	more
V0666	Field C5 - Case Vehicle (2)	019 cm	cm	more
V0667	Field C6 - Case Vehicle (2)	000 cm	No Crush	more
V0668	Direct Damage D Value = The Center of Direct Damage Offset t	+000 cm	cm	more
V0669	Specific Event # Cont(1)	9	Unknown	more
V0670	Plane of Impact Contacted Vehicle(1)	9	Unknown	more
V0671	Direct Damage Length (DDL) - Contacted Vehicle (1)	999	Unknown	more
V0672	Direct Damage Maximum Crush - Contacted Vehicle (1)	999	Unknown	more
V0673	Field L - Contacted Vehicle (1)	999	Unknown	more
V0674	Field C1 - Contacted Vehicle (1)	999	Unknown	more
V0675	Field C2 - Contacted Vehicle (1)	999	Unknown	more
V0676	Field C3 - Contacted Vehicle (1)	999	Unknown	more
V0677	Field C4 - Contacted Vehicle (1)	999	Unknown	more
V0678	Field C5 - Contacted Vehicle (1)	999	Unknown	more

V0679	Field C6 - Contacted Vehicle (1)	999	Unknown	more
V0680	Direct Damage D Value = The Center of Direct Damage Offset t	9999	offset (cm)	more
V0681	Specific Event # Contacted Vehicle (2)	9	Unknown	more
V0682	Plane of Impact Contacted Vehicle(2)	9	Unknown	more
V0683	Direct Damage Length (DDL) - Contacted Vehicle (2)	999	Unknown	more
V0684	Direct Damage Maximum Crush - Contacted Vehicle (2)	999	Unknown	more
V0685	Direct and Induced Damage Length in CM	999	Unknown	more
V0686	Field C1 - Contacted Vehicle (2)	999	Unknown	more
V0687	Field C2 - Contacted Vehicle (2)	999	Unknown	more
V0688	Field C3 - Contacted Vehicle (2)	999	Unknown	more
V0689	Field C4 - Contacted Vehicle (2)	999	Unknown	more
V0690	Field C5 - Contacted Vehicle (2)	999	Unknown	more
V0691	Field C6 - Contacted Vehicle (2)	999	Unknown	more
V0692	Direct Damage D Value = The Center of Direct Damage Offset t	9999	Offset (cm)	more

Case Vehicle Tires & Rims

[Back to Top](#)

Variable Number	Variable Name	Code Value	Code Description	Other Options
V0701	Left Front Wheel Damaged	0	No	more
V0702	Right Front Wheel Damaged	1	Yes	more
V0703	Right Rear Wheel Damaged	0	No	more
V0704	Left Rear Wheel Damaged	0	No	more
V0705	Left Front Tire Tread Type	4	All Weather	more
V0706	Right Front Tire Tread Type	4	All Weather	more

V0707	Right Rear Tire Tread Type	4	All Weather	more
V0708	Left Rear Tire Tread Type	4	All Weather	more
V0709	Left Front Carcass Construction	3	Radial	more
V0710	Right Front Carcass Construction	3	Radial	more
V0711	Right Rear Carcass Construction	3	Radial	more
V0712	Left Rear Carcass Construction	3	Radial	more
V0713	Left Front Tire Condition Precrash	0	Normal - no pre-crash problems	more
V0714	Right Front Tire Condition Precrash	0	Normal - no pre-crash problems	more
V0715	Right Rear Tire Condition Precrash	0	Normal - no pre-crash problems	more
V0716	Left Rear Tire Condition Precrash	0	Normal - no pre-crash problems	more
V0717	Left Front Tire Condition Postcrash	0	Normal - no damage to tire	more
V0718	Right Front Tire Condition Postcrash	0	Normal - no damage to tire	more
V0719	Right Rear Tire Condition Postcrash	1	Partially deflated	more
V0720	Left Rear Tire Condition Postcrash	0	Normal - no damage to tire	more
V0721	Left Front Tire Involvement	0	No	more
V0722	Right Front Tire Involvement	0	No	more
V0723	Right Rear Tire Involvement	0	No	more
V0724	Left Rear Tire Involvement	0	No	more
V0725	Left Front Tire Size	P20560R15	—	—
V0726	Right Front Tire Size	P20560R15	—	—
V0727	Right Rear Tire Size	P20560R15	—	—
V0728	Left Rear Tire Size	P20560R15	—	—
V0729	Left Front Tire Pressure (recorded in psi)	39.0 psi	Actual tire pressure in psi	more
V0730	Right Front Tire Pressure (recorded in psi)	36.0 psi	Actual tire pressure in psi	more
V0731	Right Rear Tire Pressure (recorded in psi)	12.5 psi	Actual tire pressure in psi	more
	Left Rear Tire Pressure			

V0732	(recorded in psi)	35.5 psi	Actual tire pressure in psi	more
V0733	Left Front Tread Depth	06	06/32"	more
V0734	Right Front Tread Depth	07	07/32"	more
V0735	Right Rear Tread Depth	03	03/32"	more
V0736	Left Rear Tread Depth	04	04/32"	more

Case Vehicle Fuel Tank

[Back to Top](#)

Variable Number	Variable Name	Code Value	Code Description	Other Options
V0801	Propulsive Fuel Type	1	Gasoline	more
V0802	Main Tank Location	322	Within frame/centered laterally - within vertical	more
V0803	Main Filler Cap Location	133	Right of frame laterally - above vertically	more
V0804	Main Tank Material	3	Plastic	more
V0805	Aux Tank Type	8	Not applicable (not equipped)	more
V0806	Aux Tank Location	888	Not applicable (not equipped)	more
V0807	Aux Filler Cap Location	888	Not applicable (not equipped)	more
V0808	Aux Tank Material	8	Not applicable	more

Case Vehicle Fuel Leakage

[Back to Top](#)

Variable Number	Variable Name	Code Value	Code Description	Other Options
V0901	Fuel Leakage From Crash	0	No	more

Case Vehicle Fire

[Back to Top](#)

Variable Number	Variable Name	Code Value	Code Description	Other Options
V1001	Fire In Or On Case Vehicle	0	No	more

Case Vehicle Exterior

[Back to Top](#)

Variable Number	Variable Name	Code Value	Code Description	Other Options
V1101	Hood Latch Released	0	No	more
V1102	Hood Latch Damaged	1	Yes	more
		1		

V1103	Hood Latch Jammed		Yes	more
V1104	Left Hood Hinge Damaged	1	Yes	more
V1105	Left Hood Hinge Separated	0	No	more
V1106	Right Hood Hinge Damaged	1	Yes	more
V1107	Right Hood Hinge Separated	0	No	more
V1108	Hood Remained On Vehicle	1	Yes	more
V1109	Rear Hood Edge Elevated	1	Yes	more
V1110	Edge Contacted Windshield	0	No	more
V1111	Edge Penetrated Windshield	8	Not applicable	more
V1112	Hood Latch Location	1	Front of Vehicle	more
V1113	Eng/transmissn Mount Separated	0	No	more
V1114	Steering Column Flex Couplng	9	Unknown if equipped	more
V1115	Steering Column Coupling Dam	9	Unknown	more
V1116	Steering Column Coupling Separated	9	Unknown	more
V1117	Eng Comp Telescopng Unit	88	Not currently collected	more
V1118	Compartment Unit's Original/telescoped Length Difference	888	Not currently collected	more
V1119	Left Side Body Mount Separated	8	Not applicable (unitized)	more
V1120	Upper Left A-pillar Sep	0	No	more
V1121	Lower Left A-pillar Sep	4	No separation, but damaged	more
V1122	Upper Left B-pillar Sep	0	No	more
V1123	Lower Left B-pillar Sep	0	No	more
V1124	Upper Left C-pillar Sep	0	No	more
V1125	Lower Left C-pillar Sep	0	No	more
V1126	Upper Left D-pillar Sep	8	Not applicable (not equipped)	more
V1127	Lower Left D-pillar Sep	8	Not applicable (not equipped)	more
V1128	Left Front Door Opening Cause	00	Door did not open	more
V1129	Left Rear Door Opening Cause	00	Door did not open	more
V1130	Left Front Door Jammed Closed	1	Yes	more
V1131	Left Rear Door Jammed Closed	0	No	more
V1132	Van Left Rear Door Type	8	Not applicable (not a van)	more

V1133	Left Front Glazing Availability	2	Closed	more
V1134	Left Rear Glazing Availability	2	Closed	more
V1135	Lr2 Glazing Availability	1	Fixed	more
V1136	Left Front Glazing Damage	1	Shattered	more
V1137	Left Rear Glazing Damage	1	Shattered	more
V1138	Lr2 Glazing Damage	0	No damage	more
V1139	Rear Door Type	0	No door (includes pickups)	more
V1140	Rear Door Opening Cause	8	Not applicable (no rear door)	more
V1141	Rear Door Jammed Closed	8	Not applicable (no rear door)	more
V1142	Rear Glazng Availability	8	Not Applicable (No Door)	more
V1143	Rear Glazing Damage	8	Not Applicable (No Door)	more
V1144	Luggage Partition Damaged	0	No	more
V1145	Spare Tire Status	8	Not collected	more
V1146	Trailer Hitch Type	0	No hitch	more
V1147	Trailer Type	0	No trailer	more
V1148	Rght Side Body Mount Separated	8	Not applicable (unitized)	more
V1149	Upper Right A-pillar Separated	4	No separation, but damaged	more
V1150	Lower Right A-pillar Separated	4	No separation, but damaged	more
V1151	Upper Right B-pillar Separated	4	No separation, but damaged	more
V1152	Lower Right B-pillar Separated	4	No separation, but damaged	more
V1153	Upper Right C-pillar Separated	4	No separation, but damaged	more
V1154	Lower Right C-pillar Separated	4	No separation, but damaged	more
V1155	Upper Right D-pillar Separated	0	No	more
V1156	Lower Right D-pillar Separated	0	No	more
V1157	Right Front Door Opening Cause	00	Door did not open	more
V1158	Right Rear Door Opening Cause	00	Door did not open	more
V1159	Right Front Door Jammed Closed	0	No	more

V1160	Right Rear Door Jammed Closed	0	No	more
V1161	Van Right-rear Door Type	8	Not applicable (not a van)	more
V1162	Right Front Glazing Availability	2	Closed	more
V1163	Right Rear Glazing Availability	2	Closed	more
V1164	Rr2 Glazing Availability	1	Fixed	more
V1165	Right Front Glazing Damage	0	No damage	more
V1166	Right Rear Glazing Damage	0	No damage	more
V1167	Rr2 Glazing Damage	0	No damage	more
V1168	Windshield Cracked	1	Yes	more
V1169	Windshield Broken	0	No Click for Windshield Damage figure	more
V1170	Occupant Cracked/Broke Wndshld	0	No	more
V1171	Bond Separation Extent	0	None	more
V1172	Windshield Code	99	Click for Windshield Mark figure	more
V1173	Did Sun Roof/T-Roof Open	8	Not Applicable	more

Case Vehicle Steering Column/Rim

[Back to Top](#)

Variable Number	Variable Name	Code Value	Code Description	Other Options
V1201	Steering Wheel Rim Damage	2	Severely bent	more
V1202	Number of Steering Wheel Spokes	4	4 spokes	more
V1203	Steering Wheel Spoke Damage	1	Deformed slightly	more
V1204	Steering Wheel Hub Damage	1	Occupant contact	more
V1205	Steering Wheel Location of Rim Damage	5	Entire steering wheel rim collapse	more
V1206	Aftermarket Add-on Device	0	None	more
V1207	Column Tilt Feature	2	Up	more
V1208	Column Swing-away Feature	0	Not equipped	more
V1209	Column Telescoping Feature	0	Not equipped	more
V1210	Wheel Energy Absorb Device	8	Not currently collected	more
V1211	Wheel EA Device's original/damage Dimension Difference	888	Not collected	more

V1212	Column Energy Absorb Device	88	Not collected	more
V1213	Col EA Device's Orig/compressed (or Extruded) Length Diff	888	Not collected	more
V1214	Shear Capsule Separation	888	Not collected	more
V1215	Column Vertical Rotation	0	No apparent rotation	more
V1216	Column Lateral Rotation	0	No apparent rotation	more

Case Vehicle Intrusion

[Back to Top](#)

Variable Number	Variable Name	Code Value	Code Description	Other Options
V1301	Was Occupant Compartment Intruded	1	Yes Click for Intrusion Worksheet figure Click for Intrusion figure	more
V1302	Was Intrusn Catastrophic	0	No	more
V1303	Intrusion #1	01	Intrusion Number	more
V1304	Occupant Space Number(1)	11	First row, Left seat	more
V1305	Intrud Component/obj (1)	03	Toe pan	more
V1306	Associate Event Numb (1)	1	Event #1	more
V1307	Maximum Intrusion X Axis	34 cm	Intrusion (cm)	more
V1308	Maximum Intrusion Y Axis	00 cm	0 cm or No Intrusion	more
V1309	Maximum Intrusion Z Axis	00 cm	0 cm or No Intrusion	more
V1310	Occupant Number #1 (1)	01	Occupant number 1, contact	more
V1311	Injury Number #1 (1)	06	Injury #6	more
V1312	Occupant Number #2 (1)	01	Occupant number 1, contact	more
V1313	Injury Number #2 (1)	07	Injury #7	more
V1314	Intrusion Number #2	02	Intrusion #2	more
V1315	Occupant Space Number(2)	11	First row, Left seat	more
V1316	Intrud Component/obj (2)	05	Steering column	more
V1317	Associate Event Numb (2)	1	Event #1	more
V1318	Maximum Intrusion X Axis	08 cm	Intrusion (cm)	more
V1319	Maximum Intrusion Y Axis	00 cm	0 cm or No Intrusion	more
V1320	Maximum Intrusion Z Axis	00 cm	0 cm or No Intrusion	more
V1321	Occupant Number #1 (2)	00	No contact or no intrusion	more
V1322	Injury Number #1 (2)	00	No injury or no intrusion	more
V1323	Occupant Number #2 (2)	00	No contact or no intrusion	more
V1324	Injury Number #2 (2)	00	No injury or no intrusion	more

V1325	Intrusion Number #3	03	Intrusion #3	more
V1326	Occupant Space Number(3)	11	First row, Left seat	more
V1327	Intrud Component/obj (3)	01	Instrument panel	more
V1328	Associate Event Numb (3)	1	Event #1	more
V1329	Maximum Intrusion X Axis	03 cm	Intrusion (cm)	more
V1330	Maximum Intrusion Y Axis	00 cm	0 cm or No Intrusion	more
V1331	Maximum Intrusion Z Axis	00 cm	0 cm or No Intrusion	more
V1332	Occupant Number #1 (3)	00	No contact or no intrusion	more
V1333	Injury Number #1 (3)	00	No injury or no intrusion	more
V1334	Occupant Number #2 (3)	00	No contact or no intrusion	more
V1335	Injury Number #2 (3)	00	No injury or no intrusion	more
V1336	Intrusion Number #4	04	Intrusion #4	more
V1337	Occupant Space Number(4)	12	First row, Center seat	more
V1338	Intrud Component/obj (4)	01	Instrument panel	more
V1339	Associate Event Numb (4)	1	Event #1	more
V1340	Maximum Intrusion X Axis	16 cm	Intrusion (cm)	more
V1341	Maximum Intrusion Y Axis	00 cm	0 cm or No Intrusion	more
V1342	Maximum Intrusion Z Axis	00 cm	0 cm or No Intrusion	more
V1343	Occupant Number #1 (4)	00	No contact or no intrusion	more
V1344	Injury Number #1 (4)	00	No injury or no intrusion	more
V1345	Occupant Number #2 (4)	00	No contact or no intrusion	more
V1346	Injury Number #2 (4)	00	No injury or no intrusion	more
V1347	Intrusion Number #5	05	Intrusion #5	more
V1348	Occupant Space Number(5)	13	First row, Right seat	more
V1349	Intrud Component/obj (5)	03	Toe pan	more
V1350	Associate Event Numb (5)	1	Event #1	more
V1351	Maximum Intrusion X Axis	20 cm	Intrusion (cm)	more
V1352	Maximum Intrusion Y Axis	00 cm	0 cm or No Intrusion	more
V1353	Maximum Intrusion Z Axis	00 cm	0 cm or No Intrusion	more
V1354	Occupant Number #1 (5)	00	No contact or no intrusion	more
V1355	Injury Number #1 (5)	00	No injury or no intrusion	more
V1356	Occupant Number #2 (5)	00	No contact or no intrusion	more
V1357	Injury Number #2 (5)	00	No injury or no intrusion	more
V1358	Intrusion Number #6	99	Unknown or data not collected	more
V1359	Occupant Space Number(6)	99	Unknown or data not collected	more
V1360	Intrud Component/obj (6)	99	Unknown or data not collected	more
V1361	Associate Event Numb (6)	9	Unknown or data not collected	more
V1362	Maximum Intrusion X Axis	99	Unknown or data not collected	more

V1363	Maximum Intrusion Y Axis	99	Unknown or data not collected	more
V1364	Maximum Intrusion Z Axis	99	Unknown or data not collected	more
V1365	Occupant Number #1 (6)	99	Unknown or data not collected	more
V1366	Injury Number #1 (6)	99	Contact, injury unknown or data not collected	more
V1367	Occupant Number #2 (6)	99	Unknown or data not collected	more
V1368	Injury Number #2 (6)	99	Contact, injury unknown or data not collected	more
V1369	Intrusion Number #7	99	Unknown or data not collected	more
V1370	Occupant Space Number(7)	99	Unknown or data not collected	more
V1371	Intrud Component/obj (7)	99	Unknown or data not collected	more
V1372	Associate Event Numb (7)	9	Unknown or data not collected	more
V1373	Maximum Intrusion X Axis	99	Unknown or data not collected	more
V1374	Maximum Intrusion Y Axis	99	Unknown or data not collected	more
V1375	Maximum Intrusion Z Axis	99	Unknown or data not collected	more
V1376	Occupant Number #1 (7)	99	Unknown or data not collected	more
V1377	Injury Number #1 (7)	99	Contact, injury unknown or data not collected	more
V1378	Occupant Number #2 (7)	99	Unknown or data not collected	more
V1379	Injury Number #2 (7)	99	Contact, injury unknown or data not collected	more
V1380	Intrusion Number #8	99	Unknown or data not collected	more
V1381	Occupant Space Number(8)	99	Unknown or data not collected	more
V1382	Intrud Component/obj (8)	99	Unknown or data not collected	more
V1383	Associate Event Numb (8)	9	Unknown or data not collected	more
V1384	Maximum Intrusion X Axis	99	Unknown or data not collected	more
V1385	Maximum Intrusion Y Axis	99	Unknown or data not collected	more
V1386	Maximum Intrusion Z Axis	99	Unknown or data not collected	more
V1387	Occupant Number #1 (8)	99	Unknown or data not collected	more
V1388	Injury Number #1 (8)	99	Contact, injury unknown or data not collected	more
V1389	Occupant Number #2 (8)	99	Unknown or data not collected	more
V1390	Injury Number #2 (8)	99	Contact, injury unknown or data not collected	more
V1391	Intrusion Number #9	99	Unknown or data not collected	more
V1392	Occupant Space Number(9)	99	Unknown or data not collected	more
V1393	Intrud Component/obj (9)	99	Unknown or data not collected	more
V1394	Associate Event Numb (9)	9	Unknown or data not collected	more
V1395	Maximum Intrusion X Axis	99	Unknown or data not collected	more

V1396	Maximum Intrusion Y Axis	99	Unknown or data not collected	more
V1397	Maximum Intrusion Z Axis	99	Unknown or data not collected	more
V1398	Occupant Number #1 (9)	99	Unknown or data not collected	more
V1399	Injury Number #1 (9)	99	Contact, injury unknown or data not collected	more
V1400	Occupant Number #2 (9)	99	Unknown or data not collected	more
V1401	Injury Number #2 (9)	99	Contact, injury unknown or data not collected	more
V1402	Intrusion Number #10	99	Unknown or data not collected	more
V1403	Occupant Space Number (10)	99	Unknown or data not collected	more
V1404	Intrud Component/obj(10)	99	Unknown or data not collected	more
V1405	Associate Event Numb(10)	9	Unknown or data not collected	more
V1406	Maximum Intrusion X Axis	99	Unknown or data not collected	more
V1407	Maximum Intrusion Y Axis	99	Unknown or data not collected	more
V1408	Maximum Intrusion Z Axis	99	Unknown or data not collected	more
V1409	Occupant Number #1 (10)	99	Unknown or data not collected	more
V1410	Injury Number #1 (10)	99	Contact, injury unknown or data not collected	more
V1411	Occupant Number #2 (10)	99	Unknown or data not collected	more
V1412	Injury Number #2 (10)	99	Contact, injury unknown or data not collected	more
V1413	Intrusion Number (a)	88	Not Applicable	more
V1414	Cause Of Intrusion (a)	8	Not applicable	more
V1415	Intrusion Number (b)	88	Not Applicable	more
V1416	Cause Of Intrusion (b)	8	Not applicable	more
V1417	Intrusion Number (c)	88	Not Applicable	more
V1418	Cause Of Intrusion (c)	8	Not applicable	more
V1419	Intrusion Number (a)	88	Not Applicable	more
V1420	Damaged Component 1 (a)	8	Not Applicable	more
V1421	Damaged Component 2 (a)	8	Not Applicable	more
V1422	Intrusion Number (b)	88	Not Applicable	more
V1423	Damaged Component 1 (b)	8	Not Applicable	more
V1424	Damaged Component 2 (b)	8	Not Applicable	more
V1425	Intrusion Number (c)	88	Not Applicable	more
V1426	Damaged Component 1 (c)	8	Not Applicable	more
V1427	Damaged Component 2 (c)	8	Not Applicable	more
V1428	Intrusion Number (d)	88	Not Applicable	more
V1429	Damaged Component 1 (d)	8	Not Applicable	more
V1430	Damaged Component 2 (d)	8	Not Applicable	more

Case Vehicle Airbag(s)

[Back to Top](#)

Variable Number	Variable Name	Code Value	Code Description	Other Options
V1501	Driver Airbag Equipped	1	Yes Click for Driver Airbag figure	more
V1502	Right Front Airbag Equip	1	Yes Click for Passenger Airbag figure	more
V1503	Left Rear Airbag Equipped	0	No	more
V1504	Right Rear Airbag Equipped	0	No	more
V1505	Driver Airbag Deployed	1	Yes	more
V1506	Rght Front Airbag Deploy	1	Yes	more
V1507	Left Rear Airbag Deploy	8	Not applicable (no airbag)	more
V1508	Rught Rear Airbag Deploy	8	Not applicable (no airbag)	more
V1509	Driver On/off Switch	0	Not equipped (no switch)	more
V1510	Rght Front On/off Switch	0	Not equipped (no switch)	more
V1511	Left Rear On/off Switch	8	Not applicable (no airbag)	more
V1512	Right Rear On/off Switch	8	Not applicable (no airbag)	more
V1513	Driver Airbag Location	1	Steering wheel	more
V1514	Right Front Airbag Location	2	Top instrument panel	more
V1515	Left Rear Airbag Location	0	No airbag	more
V1516	Right Rear Airbag Location	0	No airbag	more
V1517	Driver Airbag Condition	0	No damage	more
V1518	Right Front Airbag Condition	0	No damage	more
V1519	Left Rear Airbag Condition	8	Not applicable (not equipped / not deployed)	more
V1520	Right Rear Airbag Condition	8	Not applicable (not equipped / not deployed)	more

Driver Airbag

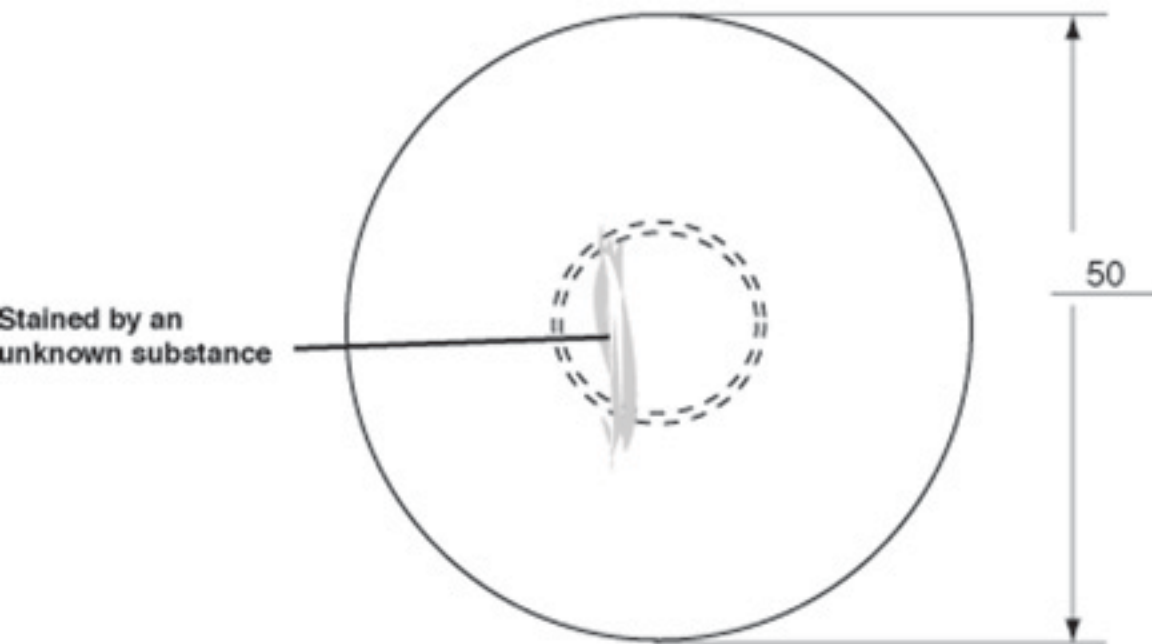

Driver Airbag Doors

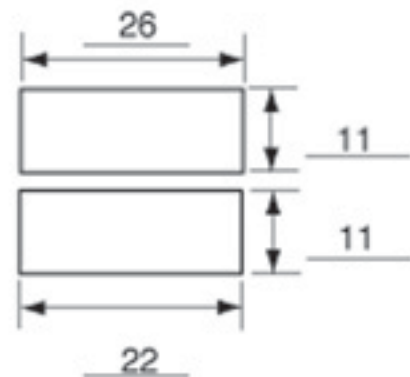

Vents: Y N
 if yes, how many: 2
 Vents @ 11 and 1 o'clock

Tethers: Y N
 if yes, how many: 4

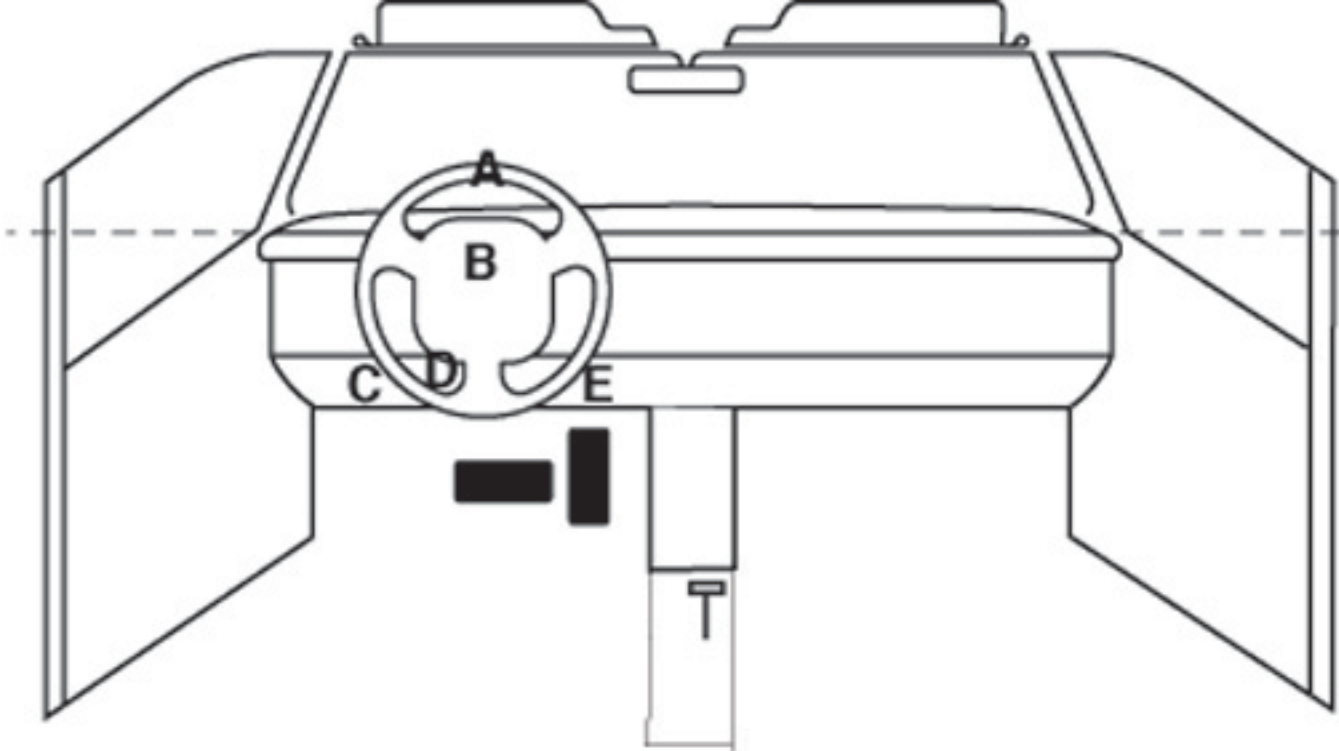

A = upper steering-wheel rim, bent forward

B = upper airbag cover, scuffed

C = knee bolster left of steering column, dented and scuffed

D = steering column, scuffed

E = knee bolster right of steering column, plastic cracked and scuffed

1 = Definitely 2 = Probably 3 = Possible

INTRUSION IT-1

Location of Intrusion	Intruded Component	(All Measurements Are in Centimeters)					Dominant Crush Direction
		Comparison Value	–	Intruded Value	=	Intrusion	
11	Toe pan	123	–	89	=	34	rear
11	Steering column	62	–	54	=	8	rear
11	Instrument panel	67	–	64	=	3	rear
			–		=		
12	Center stack	74	–	58	=	16	rear
			–		=		
13	Toe pan	123	–	103	=	20	rear
			–		=		
			–		=		
			–		=		
			–		=		
			–		=		
			–		=		

OCCUPANT CONTACT WORKSHEET

Contact	Interior Component Contacted	Occupant No. if Known	Body Region if Known	Supporting Physical Evidence	Confidence Level of Contact Point
A	Steering wheel rim	DR	Chest and Rt. arm	bent forward	1
B	Upper airbag cover	DR	Chest	scuffed	2
C	Knee bolster - left	DR	Lt. LX	dented and scuffed	1
D	Steering column	DR	UX	scuffed	1
E	Knee bolster - right	DR	Rt. UX	plastic cracked and scuffed	1
F					
G					

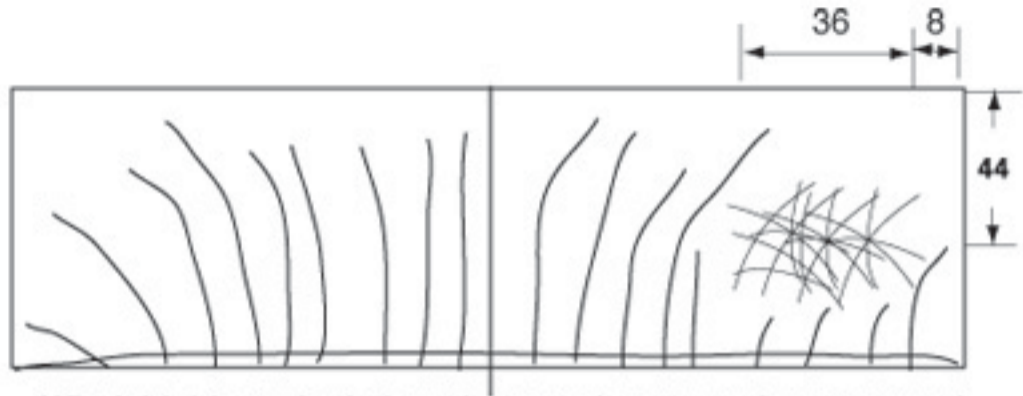

Windshield cracked along bottom due to cowl contact and right due to contact by dash-mounted passenger side airbag cover

WINDSHIELD MARK ON CASE VEHICLE:

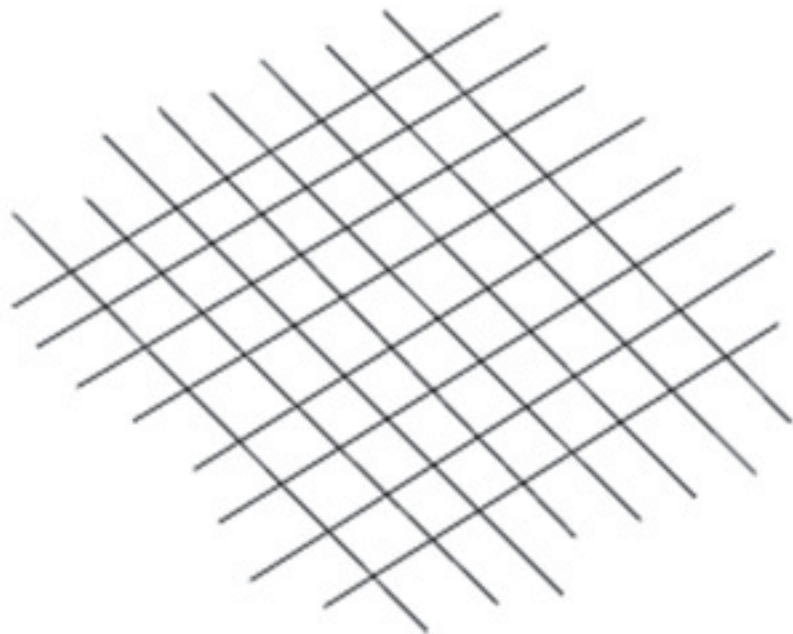

Lower portion of right-front wheel displaced inward

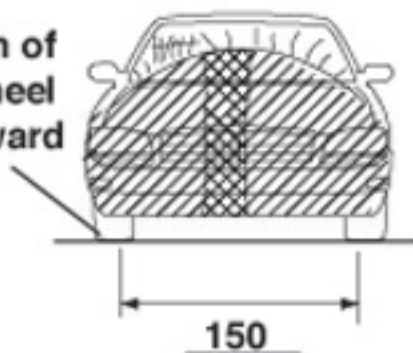

Original Bumper Height
22

30

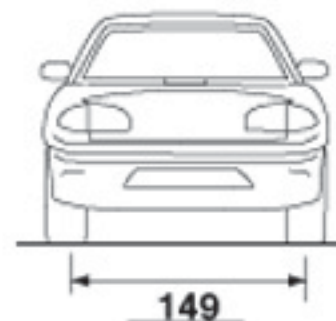

Tree bark in bead of left -front tire

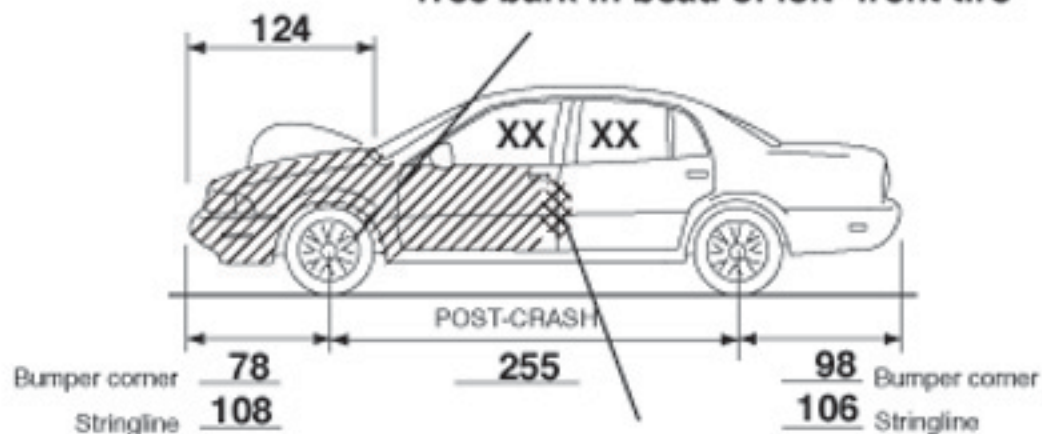

Door pried open by rescue personnel

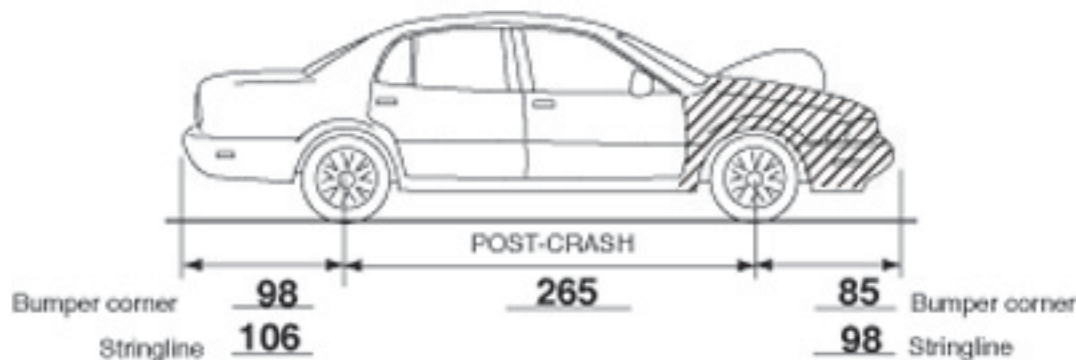

Max. crush to center of front bumper

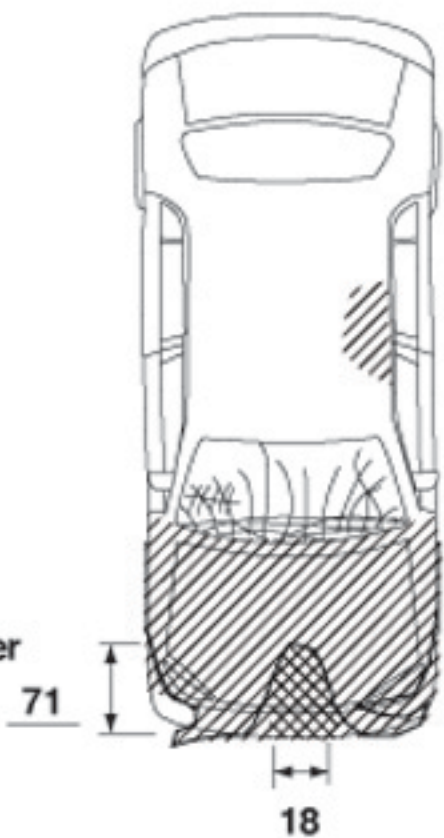

Width of direct damage to front

Passenger Airbag

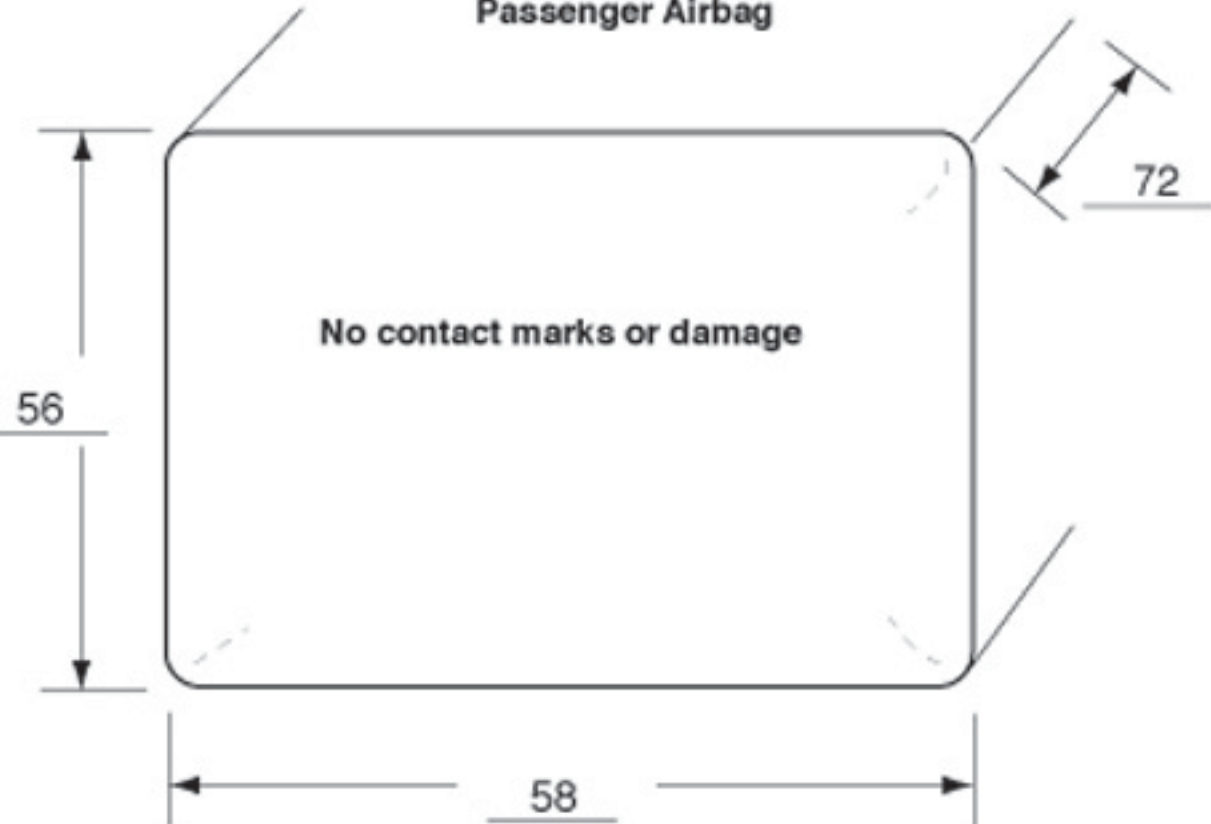

Passenger Airbag Door

Single Door

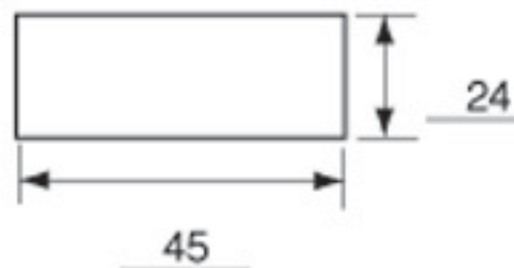

Vents: Y N

if yes, how many: 2
vents @ 3 and 9 o'clock

Tethers: Y N

if yes, how many: 2

























































LAVES
8-4626



















602010







602010



Contour
Sport

24V









010

SE







602010

FLORIDA
FLB































LIMIT
70
TRUCK
55

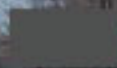

SPEED
LIMIT
70
TRUCKS
55

Walmart





SPEED
LIMIT
70
TRUCKS
55





2002 6024BA

