

**HIGHLY AUTOMATED VEHICLES:  
FEDERAL PERSPECTIVES ON THE DEPLOYMENT  
OF SAFETY TECHNOLOGY**

---

---

**HEARING**

BEFORE THE

**COMMITTEE ON COMMERCE,  
SCIENCE, AND TRANSPORTATION  
UNITED STATES SENATE**

ONE HUNDRED SIXTEENTH CONGRESS

FIRST SESSION

NOVEMBER 20, 2019

Printed for the use of the Committee on Commerce, Science, and Transportation



Available online: <http://www.govinfo.gov>

U.S. GOVERNMENT PUBLISHING OFFICE

WASHINGTON : 2023

SENATE COMMITTEE ON COMMERCE, SCIENCE, AND TRANSPORTATION

ONE HUNDRED SIXTEENTH CONGRESS

FIRST SESSION

ROGER WICKER, Mississippi, *Chairman*

JOHN THUNE, South Dakota	MARIA CANTWELL, Washington, <i>Ranking</i>
ROY BLUNT, Missouri	AMY KLOBUCHAR, Minnesota
TED CRUZ, Texas	RICHARD BLUMENTHAL, Connecticut
DEB FISCHER, Nebraska	BRIAN SCHATZ, Hawaii
JERRY MORAN, Kansas	EDWARD MARKEY, Massachusetts
DAN SULLIVAN, Alaska	TOM UDALL, New Mexico
CORY GARDNER, Colorado	GARY PETERS, Michigan
MARSHA BLACKBURN, Tennessee	TAMMY BALDWIN, Wisconsin
SHELLEY MOORE CAPITO, West Virginia	TAMMY DUCKWORTH, Illinois
MIKE LEE, Utah	JON TESTER, Montana
RON JOHNSON, Wisconsin	KYRSTEN SINEMA, Arizona
TODD YOUNG, Indiana	JACKY ROSEN, Nevada
RICK SCOTT, Florida	

JOHN KEAST, *Staff Director*

CRYSTAL TULLY, *Deputy Staff Director*

STEVEN WALL, *General Counsel*

KIM LIPSKY, *Democratic Staff Director*

CHRIS DAY, *Democratic Deputy Staff Director*

RENAE BLACK, *Senior Counsel*

## CONTENTS

---

	Page
Hearing held on November 20, 2019 .....	1
Statement of Senator Wicker .....	1
Statement of Senator Cantwell .....	3
Statement of Senator Thune .....	21
Statement of Senator Peters .....	24
Statement of Senator Fischer .....	27
Statement of Senator Capito .....	31
Statement of Senator Schatz .....	33
Statement of Senator Udall .....	35
Statement of Senator Duckworth .....	36
Statement of Senator Tester .....	38
Statement of Senator Markey .....	40
Letter dated November 19, 2019 from Senator Edward J. Markey to Elon Musk, Co-Founder and CEO, Tesla .....	42
Consumer Watchdog report .....	50
Statement of Senator Blumenthal .....	44
Statement of Senator Sinema .....	47
Statement of Senator Rosen .....	48

### WITNESSES

Hon. Joel Szabat, Acting Under Secretary for Policy, Department of Transportation .....	4
Prepared statement .....	5
Dr. James C. Owens, Acting Administrator, National Highway Traffic Safety Administration .....	8
Prepared statement .....	9
Hon. Robert L. Sumwalt III, Chairman, National Transportation Safety Board .....	14
Prepared statement .....	15

### APPENDIX

Letter dated November 18, 2019 to Chairman Wicker and Ranking Member Cantwell from Jamie Boone, Vice President, Government Affairs, Consumer Technology Association .....	101
Letter dated November 19, 2019 to Hon. Roger Wicker and Hon. Maria Cantwell from Tim Day, Senior Vice President, C—TEC U.S. Chamber of Commerce .....	104
Letter dated November 19, 2019 to Hon. Roger Wicker and Hon. Maria Cantwell from Brad Stertz, PAVE Co-Chair, Director of Government Affairs, Audi USA and Kelly Nantel, PAVE Co-Chair, Vice President of Communications and Advocacy, National Safety Council .....	104
Letter dated November 20, 2019 to Chairman Roger Wicker and Ranking Member Maria Cantwell from Gerardo Interiano, Head of Government Relations, Aurora .....	105
Letter dated November 20, 2019 to Hon. Roger Wicker and Hon. Maria Cantwell from Robyn Boerstling, Vice President, Infrastructure, Innovation and Human Resources Policy, National Association of Manufacturers .....	106
Letter dated November 20, 2019 to Chairman Wicker and Ranking Member Cantwell from David Estrada, Chief Legal and Policy Officer, Nuro .....	112
Letter dated November 20, 2019 to Hon. Roger Wicker and Hon. Maria Cantwell from Robbie Diamond, President and CEO, Securing America's Future Energy .....	114

IV

	Page
Letter dated November 20, 2019 to Chairman Wicker and Ranking Member Cantwell from Danielle Burr, Head of Federal Affairs, Uber .....	115
Catherine Chase, President, Advocates for Highway and Auto Safety, prepared statement .....	117
Ian Jefferies, President and Chief Executive Officer, Association of American Railroads, prepared statement .....	130
Prepared statement of American Property Casualty Insurance Association .....	133
John Bozzella, President and CEO, Association of Global Automakers, Inc., prepared statement .....	134
Prepared statement of the National Association of Mutual Insurance Companies .....	136
Prepared statement of the National Safety Council .....	139
Response to written questions submitted to Hon. Joel Szabat by:	
Hon. Jerry Moran .....	143
Hon. Marsha Blackburn .....	144
Hon. Todd Young .....	144
Hon. Maria Cantwell .....	145
Hon. Jon Tester .....	146
Response to written questions submitted to Dr. James C. Owens by:	
Hon. John Thune .....	146
Hon. Deb Fischer .....	147
Hon. Roy Blunt .....	148
Hon. Jerry Moran .....	148
Hon. Todd Young .....	150
Hon. Maria Cantwell .....	151
Hon. Amy Klobuchar .....	153
Hon. Edward Markey .....	153
Hon. Jon Tester .....	155
Response to written questions submitted to Hon. Robert L. Sumwalt III by:	
Hon. Jerry Moran .....	155
Hon. Roy Blunt .....	156
Hon. Todd Young .....	157
Hon. Maria Cantwell .....	158
Hon. Amy Klobuchar .....	159



**HIGHLY AUTOMATED VEHICLES:  
FEDERAL PERSPECTIVES ON THE  
DEPLOYMENT OF SAFETY TECHNOLOGY**

---

**WEDNESDAY, NOVEMBER 20, 2019**

U.S. SENATE,  
COMMITTEE ON COMMERCE, SCIENCE, AND TRANSPORTATION,  
*Washington, DC.*

The Committee met, pursuant to notice, at 10:01 a.m., in room SH-216, Hart Senate Office Building, Hon. Roger Wicker, Chairman of the Committee, presiding.

Present: Senators Wicker [presiding], Thune, Blunt, Fischer, Blackburn, Capito, Young, Scott, Cantwell, Blumenthal, Schatz, Markey, Peters, Duckworth, Tester, Sinema, and Rosen.

**OPENING STATEMENT OF HON. ROGER WICKER,  
U.S. SENATOR FROM MISSISSIPPI**

The CHAIRMAN. The hearing will come to order and we've been told that it's all right to begin. The Committee convenes today for a hearing to examine Highly Automated Vehicles: Federal perspectives on the deployment of safety technology. I'm glad to convene this hearing. Senator Cantwell and her staff will be here momentarily.

I want to welcome our panel of witnesses and thank them for appearing. We'll hear from Mr. Joel Szabat, Acting Under Secretary of Transportation for Policy; Dr. James Owens, Acting Administrator of National Highway Traffic Safety Administration or NHTSA; and Mr. Robert Sumwalt, Chair of the National Transportation Safety Board.

Today's hearing will focus on the Federal Government's role in realizing the opportunities offered by automated vehicles [AVs]. These technological advancements in the transportation industry have the potential to revolutionize our society by improving safety and mobility for all Americans. This committee is advancing the safe testing and deployment of this technology.

As the fatal crash in Tempe, Arizona, highlights, safety is and will continue to be paramount. In the Tempe crash, Ms. Elaine Herzberg was tragically struck and killed by an Uber test vehicle while crossing the street. Records show that the vehicle detected Ms. Herzberg's—Mrs. Herzberg's presence 5.6 seconds before the crash, but failed to brake. It is imperative that manufacturers learn from this incident and prevent similar tragedies from happening again.

Today's hearing provides an opportunity to discuss how these safety challenges can be addressed while continuing to move forward with this technology. The witnesses should discuss best practices and ongoing efforts to ensure safety, that is a priority during testing.

Recently, the Department of Transportation started to update its processes and regulations through guidance documents, requests for information, grants, and proposed rulemakings. I commend Secretary Chao's work across modal agencies, including through the Non-traditional and Emerging Transportation Technology or NETT Council, to help Federal policy keep pace with innovation.

I invite today's witnesses to update the Committee on the Department's efforts to oversee and regulate AVs and describe next steps in this process. The Committee seeks recommendations on how Congress may further support the Department of Transportation's work on automated vehicles.

These recent efforts are a step in the right direction. But, with AVs already being tested on our roads in more than 34 states, strong Federal leadership is required to govern the successful implementation of this technology. This year, the Commerce Committee has restarted its efforts to craft legislation to set a Federal regulatory framework governing the safety of AVs. Led by Senators Thune and Peters, this Committee is working with the House Energy and Commerce Committee to draft bipartisan, bicameral legislation through a consultative process involving stakeholders. The Committee have already received more than 100 letters from industry, state and local governments, and consumer and disability advocates.

Today's hearing is an opportunity for witnesses to share further information that may instruct Congress's work on AV legislation. We would like to hear how such legislation would advance AV integration and testing and facilitate deployment of AVs.

As we continue to develop a regulatory framework, the discussion should also be driven by the potential benefits of AVs to improve the country's transportation systems. According to NHTSA, more than 36,000 people were killed on U.S. roads last year. Ninety-four percent of all traffic crashes are due to human error. Automated technology thus has the potential to save thousands of lives by reducing crashes due to impairment, distraction, fatigue, and more.

In addition to improving safety, AVs represent an opportunity to provide greater mobility to different segments of the population. AV technology could improve transportation for the disabled and the elderly, giving them newfound independence.

As technology continues to improve, AVs will be increasingly part of our daily lives. Therefore, it is up to us to ensure that the safety benefits of these vehicles are fully realized. KPMG found that, while the U.S. is home to the world's leading AV companies, the U.S. ranks 9th in the world in legislation and policy governing AVs. Without a strong national approach, other countries will have the opportunity to take our place as a leader in this field.

I look forward to a good discussion with the witnesses and my colleagues today as we consider the safe testing and development of automated vehicles. I now turn to my friend and Ranking Member, Senator Cantwell.

**STATEMENT OF HON. MARIA CANTWELL,  
U.S. SENATOR FROM WASHINGTON**

Senator CANTWELL. Thank you, Mr. Chairman, and thank you for holding this hearing. And I would be remiss if I didn't thank Senator Thune and Senator Peters for their longstanding work and coordination on this issue. We're here today because we want to discuss the issues of technology advancements that we've had in the past, such as everything from seatbelts to airbags to electronic stability controls and how it's helped us.

You mentioned the number of incidents, yet tragically, more than 36,000 people died on our roadways in 2018. This remains far too many. Today over 90 percent of our roadways fatalities are contributed to human error and there are ways in which advancements in technology have the potential to drive down these numbers. But obviously we have to talk about how these technologies and automation are affecting our vehicles and the importance of the human element process.

Research also consistently shows that drivers disengage from a task of driving when using automated tools. I believe the interaction between humans and technology, particularly this whole area of automation, is one that we know is going to be very much part of the future, but needs a lot more attention.

Over the past 3 years, more companies have been putting automated vehicles, otherwise known as AVs, out on the road, and sometimes ending in fatal consequences. In several of these accidents, the drivers were not paying attention to the roadway and unable to intervene to avoid the crash. Drivers relied on technology to safely operate as intended, and when the technology failed, the consequences were severe. This pattern with AV technologies cannot continue. So what we need to do is continue to learn from these lessons and make sure that we're putting safeguards in place.

Just yesterday, the National Transportation Safety Board held a hearing on a fatal crash involving one of Uber's automated test vehicles. The NTSB noted that Uber made the decision to remove an automated braking system before testing the AV out on the road, which left the driver as the last line of defense. The driver's inattentiveness led to a pedestrian being fatally struck by this test vehicle. The NTSB highlighted Uber's poor safety culture, which ultimately led to this unbelievably tragic death. So I want to thank the NTSB for being here today and for your continued work.

Uber has made changes to address the safety culture in response to the NTSB, but I want to make a point that a positive safety culture everywhere is helpful to all of us. Over 80 companies are currently testing automated vehicles on the public roadways, and we need to know that everyone has safety at the forefront of their decisions. We need to know what Federal regulators are doing to ensure companies are thoughtful through these testing issues. And as I said, I feel like we as an entity can do a lot more on this human-technology interface, and knowing what to do about it and what the response times could possibly be.

The National Highway Safety Transportation Administration has voluntary safety assessments as a way for companies to communicate how they are prioritizing safety. However, some of these self-assessments read more like a marketing brochure than critical as-

assessments. Noticeably missing from the list of companies that submitted voluntary assessments were Tesla and Uber, both of which had fatal incidents.

So I do think it raises a question about what kind of structure we need to have in place to make sure that these safety safeguards are not just voluntary, but have to be met, and that the regulators are playing their role.

So Mr. Chairman I look forward to hearing more at the hearing today about these important issues and, again, thank you to our witnesses for being here.

The CHAIRMAN. Thank you Senator Cantwell and we'll now begin our testimony with Mr. Szabat. Thank you sir for being here.

**STATEMENT OF HON. JOEL SZABAT,  
ACTING UNDER SECRETARY FOR POLICY,  
DEPARTMENT OF TRANSPORTATION**

Mr. SZABAT. Good morning Chairman Wicker, Ranking Member Cantwell, and distinguished Members of the Committee. Thank you for inviting me to testify today on behalf of the United States Department of Transportation and Secretary Elaine L. Chao. We're testifying about the Department's efforts to support the safe and full integration of automated vehicles into the Nation's transportation system.

The Secretary's top priority for the department has been, is and will remain safety. One of our other priorities is for the Department to engage with emerging technologies to ensure that legitimate concerns over safety, security and privacy are addressed without hampering innovation. These advanced vehicle technologies have the potential for improving safety on our roads. As the Chairman just mentioned, human behavior is a factor in up to 94 percent of serious crashes.

Our focus on safety was clarified in the September 2017 release of *Automated Driving Systems 2.0, A Vision for Safety*, which serves as the cornerstone for automated vehicle efforts.

This approach was fundamental to the development of *Automated Vehicles 3.0, Preparing for the Future of Transportation*. This document expanded the scope to provide a framework for a multimodal approach to the safe and full integration of automated vehicles into our nation's broader surface transportation system. A point that Ranking Member Cantwell just made. The vision laid out an AV 3.0, serves as a foundation for the actions the Department is taking today.

For example, in September, Secretary Chao announced \$60 million in automated driving system demonstration grants for eight projects in seven states. These grants were focused first and foremost on the safe demonstration of these technologies. Second, on the inclusion of all relevant stakeholders in the community where these demonstrations occur, signifying a broad coalition of engaged and willing stakeholders. Last, on generating the actual data needed to help update future regulations and standards.

Similarly, one of the key areas of focus for the Department is the development of automated vehicle technology for use by people with all types of disabilities. We take to heart the mantra, nothing about us, without us; including people who have disabilities in deci-

sionmaking process, as accessibility technologies developed. We hope this message resonated in particular to the inclusive design challenge which Secretary Chao announced as part of the nearly \$50 million—as part of nearly \$50 million in accessibility-related research and technology deployment at the recent Access and Mobility For All summit.

We are also working with our partners across the Federal Government to ensure a coordinated and comprehensive approach to these technologies. Working with the White House Office of Science and Technology Policy. We are leading in development of a document that will catalog all actions being taken by over 30 Federal agencies, expanding the principles from AV 3.0, and helping to provide a full understanding of the U.S. Government’s investments and engagements with these technologies.

In addition, the Department is working to publish a comprehensive plan that outlines the steps needed to be taken from where we are today to the safe and full integration of these technologies into the American transportation system. The Department appreciates the collaborative relationship it has enjoyed with this committee and with the Congress as it seeks to update legislation regarding automated vehicles. It is vital to understand your congressional priorities as we work to update our regulations, conduct policy initiatives, and shape our research into these areas.

We look forward to this continued collaborative relationship and working with you to ensure the future of the American transportation system and that it is safer, more efficient, and more accessible for all. Thank you. I look forward to answering your questions.

[The prepared statement of Mr. Szabat follows:]

PREPARED STATEMENT OF HON. JOEL SZABAT, ACTING UNDER SECRETARY FOR  
POLICY, DEPARTMENT OF TRANSPORTATION

Good morning Chairman Wicker, Ranking Member Cantwell, and distinguished Members of the Committee. Thank you for inviting me to testify on behalf of the United States Department of Transportation (USDOT) and Secretary Elaine L. Chao about the Department’s efforts to support the safe and full integration of automated vehicles into the Nation’s transportation system.

The Department has previously testified about the safety potential of advanced vehicle technologies, including Advanced Driver Assistance Systems (ADAS) and Automated Driving System (ADS) technologies. These advanced vehicle technologies have the potential to mitigate crashes associated with irresponsible and often illegal behavior by assuring compliance with traffic laws, eliminating driver distraction, and improving vehicle responses to emergency situations.

At the beginning of this Administration, the National Highway Traffic Safety Administration (NHTSA) led in the development and publication of *Automated Driving Systems 2.0, A Vision for Safety* (ADS 2.0). ADS 2.0 improves and refines previous policy and incorporates feedback received through public comments and Congressional hearings. ADS 2.0 supports the safe deployment of automated vehicle automated driving systems (ADS) by providing voluntary guidance that encourages best practices and prioritizes safety.

This focus on safety served as the cornerstone for the Department’s efforts to develop an updated, multi-modal guidance document: *Preparing for the Future of Transportation: Automated Vehicles 3.0 (AV 3.0)*<sup>1</sup>. AV 3.0 provides a framework and multimodal approach for the safe integration of ADS technology into the Nation’s broader surface transportation system.

<sup>1</sup> <https://www.transportation.gov/sites/dot.gov/files/docs/policy-initiatives/automated-vehicles/320711/preparing-future-transportation-automated-vehicle-30.pdf>

The multimodal approach enshrined in 3.0 adds to, the work NHTSA is doing regarding the safety of the vehicles and vehicle equipment by including roads and road users to the automation safety equation. The guidance includes:

1. The Federal Motor Carrier Safety Administration (FMCSA) existing authorities around the safe operation of commercial motor vehicles;
2. The Federal Transit Administration (FTA) safety authority over public transportation; and,
3. The state and local transportation agencies, whose work is preparing for the impacts of automation on infrastructure.

AV 3.0 also includes other transportation modes at USDOT engaging with vehicle automation, such as the Maritime Administration (MARAD), the Federal Railroad Administration (FRA), and the Pipeline and Hazardous Materials Administration (PHMSA), and the Federal Aviation Administration (FAA) which provided input based on its decades of experience with automation in aviation, as aircraft automation provides greater levels of safety and efficiency in aviation operations. Many lessons learned and safety approaches in aviation are considered by the automotive industry.

As described above, the Department involved multiple modes and broad stakeholder groups to establish a holistic and durable framework. In addition, the Department laid out a number of key principles for how to address the public's concerns regarding the safety, security, and privacy of these technologies.

AV 3.0 provided new safety guidance, building upon what we already knew and expanding it to emerging modes of transportation. It reduced some of the policy uncertainty our partners face as they approach difficult, novel, and complex questions, and outlines the process for working with the USDOT.

So, first and foremost, safety is our top priority. The Department will lead efforts to address potential safety risks and advance the life-saving potential of automation, which will not only protect the public from any potential safety risks but also strengthen public confidence in these emerging technologies. Secondly, we will be technology neutral. The government will not dictate what types of technologies innovators must use to achieve higher levels of safety. We are dedicated to using the 5.9 GHz band for transportation safety purposes, and for near-term innovations such as automation and artificial intelligence, but we do not want to be prescriptive regarding whether they should use Dedicated Short Range Communications (DSRC), Cellular Vehicle to Everything (C-V2X) or a future 5G technology. While we are "technology-neutral," we care deeply about safety outcomes and will require proof that a crash-prevention technology works in the most dynamic and complex of transportation scenarios that are most frequent cause of crashes. We support an innovative ecosystem that will produce technology with the best benefits for safety and for crash prevention capabilities, which also delivers congestion mitigation, and deployed.

We will continue to modernize our regulations. NHTSA has numerous ongoing rulemakings related to automated vehicles, and ADAS and ADS technology. FMCSA is also continuing to work on revisions to its regulations, while FHWA is working to update the Manual of Uniform Traffic Control Devices to take into account AVs.

We are preparing proactively for automation. This includes not only the work of updating regulations, but also thinking through the potential workforce impacts and training needs, working with industry and stakeholders to describe the capabilities and limitations of the technologies, and identifying and managing data needs while ensuring privacy and addressing security impacts.

And, finally, we seek to ensure that people understand that the Department is seeking to provide additional options for safe transportation, including emerging and non-traditional modes driven by innovation. We must prepare for a future where there are traditional vehicles driving side-by-side with vehicles that include many different types of advanced technologies, some with no human driver at all.

One of the most tangible outputs of AV 3.0 to date has been the \$60 million Automated Driving System Demonstration Grants in Federal funding announced by Secretary Chao on September 18, 2019. The Department received 73 applications<sup>2</sup> for these grants, and awarded eight grants in seven states. These grants focus on the ability to demonstrate these technologies safely, so that people can see, touch, and learn about them. It is our hope that the more Americans can engage with these technologies, the more comfortable they may become with them. The ADS Demonstration Grants also required applicants to bring together partnerships in the community that harness the collective expertise, ingenuity, and knowledge of mul-

<sup>2</sup><https://www.transportation.gov/av/grants>

multiple stakeholders to support technology deployment and understanding. This ensures that there is a level of education and comfort with the types of demonstrations envisioned. The awards also focus on generating the types of data that may be useful to the Department as it evaluates the safety of AV. The ADS Demonstration Grants are required to generate the data that may someday help safety experts, economists, or regulatory lawyers focusing on future regulatory paths.

Accessibility also remains a key area of focus for the Department. One of the important documents for laying the groundwork for our accessibility initiatives prior to AV 3.0 was the publication by our Bureau of Transportation Statistics of *Travel Patterns of American Adults with Disabilities*.<sup>3</sup> This report identified that most Americans will have a disability at some point in their lifetime, whether it's visual, auditory, cognitive, or mobility-related, or through the challenges of becoming older. Automated vehicle technologies can open new labor opportunities, or help people connect with their families and communities. As the Department works through its initiatives, we continue to encourage the industry to focus on a vision of universal accessibility and universally designed products that accommodate individual preferences and abilities. The Department will protect the ability of consumers to make the mobility choices that best suit their needs. We will support automation technologies that enhance individual freedom by expanding access to safe and independent mobility to people with disabilities and older Americans.

One of the ways the Department is focusing on accessibility and working proactively with stakeholders is through the Inclusive Design Challenge, which Secretary Chao announced October 29, 2019 at the Access and Mobility for All Summit. This challenge, which will make up to \$5 million in cash prizes available, was developed alongside innovators, people with disabilities and advocacy groups, to support the development of vehicle design solutions to enable accessible automated vehicles. The Department aims to increase availability and decrease cost of aftermarket modifications that improve accessibility of vehicles today and spark development for future automated vehicles.

The Department has also been working with partners across the Federal Government, industry, labor, and the public on the potential impacts of Automated Vehicle Technologies to the American workforce. The Department is conducting a study alongside the Departments of Labor, Health and Human Services, and Commerce to address issues pertaining to the workforce with the introduction and adoption of automation, primarily focused on impacts to commercial motor vehicle and transit bus operators. The study focuses on labor force transformation/labor force training, technology, operational safety, and quality of life.

The AV 3.0 document continued this conversation, noting that this is not the first time the Department has faced concerns over people losing their jobs because of automation. The FAA has dealt with this question going back decades, as auto-pilot technologies developed. These concerns were understandable, but today we see that pilots are still very highly valued, very highly respected, and well-paid, and there is still a shortage of airline pilots. Automation improved their lives in many ways, notably improving safety and the quality of their jobs. While we cannot predict the development of automated trucking technologies, we've seen similar issues in the past and we must learn from these experiences.

As we look at all the AV-related actions across the government, we have asked ourselves how to best ensure they are aligned, complementary and non-duplicative. We are doing this in two ways.

First, the USDOT is working hand-in-hand with the White House Office of Science and Technology Policy to catalogue and align all of the activities among all of our Federal partners to ensure they are aligned under one set of principles. There are over 30 Federal agencies working in this area, with actions and authorities that can help provide a full understanding of the U.S. government's investments and engagements with the technologies. There is great value in bringing together this information in one place so that all partners—Congress, Federal, State, local, tribal, industry, advocacy groups and the public—can have a better understanding of the entire ecosystem.

Second, work continues on a comprehensive plan for the safe and full integration of automated vehicle technology into our national transportation system. As part of any comprehensive plan, one must envision the end state, compare it to the current situation, and outline the actions that the Department needs to take to support this future. As envisioned in AV 3.0, the foundation for this document will be the Department's approach to safety.

The Department looks forward to continuing to work with the Committee and the Congress to provide feedback and technical assistance on any automated vehicle-re-

<sup>3</sup><https://www.bts.gov/topics/passenger-travel/travel-patterns-american-adults-disabilities>

lated bills or provisions. The Department has appreciated the opportunity to work closely with our Congressional partners on ongoing legislative development, as well as focusing the regulatory updates, policy initiatives, and research needed to enable a future with a safer and more efficient transportation system for all.

Thank you, and I look forward to answering any questions you may have.

The CHAIRMAN. Thank you very much, Mr. Szabat. Dr. Owens, you're recognized for 5 minutes.

**STATEMENT OF DR. JAMES C. OWENS,  
ACTING ADMINISTRATOR,  
NATIONAL HIGHWAY TRAFFIC SAFETY ADMINISTRATION**

Dr. OWENS. Good morning Mr. Chairman, Ranking Member Cantwell and Members of the Committee. Thank you for inviting me to testify today regarding NHTSA's efforts under the leadership of Secretary Elaine Chao to facilitate the safe testing and deployment of advanced vehicle technologies.

Safety is NHTSA's number one priority and we work to enhance vehicle and highway safety by using the wide variety of tools at our disposal. We exercise broad enforcement authority to require the recall of any vehicle or equipment, including software, that poses an unreasonable risk to safety. The Agency also adopts safety standards when technologies are proven and the standards are supported by clear evidence and sound science. We conduct research into technology and behavior to help make vehicles and their drivers safer and we partner with state and local officials to improve highway safety and with many stakeholders to raise public awareness about safe driving behaviors.

Our efforts are making a difference. Over the past 50 years our Nation has seen a dramatic decline in crash fatality rates, but we still lost 36,560 lives on our highways last year, so we still have a long way go.

New vehicles are safer than ever before, but we believe that new technologies can and will make them even safer in the future. Today, developers are investing billions of dollars in advanced technologies that are helping drivers avoid crashes or reduce the severity of crashes that do occur. This innovation is leading to growing levels of automation that can address some of the unsafe driving behaviors that cause most serious crashes.

The United States leads the world in advanced vehicle technologies because innovators are able to develop safety enhancing technologies here. NHTSA exercises careful oversight over these developing technologies by closely communicating with developers, conducting research into emerging technologies and human factors, investigating incidents and complaints, and when necessary and appropriate, exercising our broad enforcement authority. And when the time is right, when the technology is proven, we may adopt performance-based standards for automated vehicles.

Importantly all vehicles on our roads today, even those being tested, require an operator to be in control or ready to take control as a fallback and the operator is responsible for ensuring the safe operation of their vehicle at all times. NHTSA is engaged in research on these emerging technologies as technologies advance from traditional vehicles to those with increasing levels of automation, we must address the ability of human drivers to assume con-



trol when necessary. NHTSA is currently engaged in human factors research to evaluate various methods for notifying and engaging the driver as needed to maintain safe operation of the vehicle.

Vehicles with advanced levels of automation will affect more than just their operators and occupants. We are researching how these vehicles can influence and take into consideration the behavior of pedestrians, bicyclists, and other vehicles. NHTSA began exploring ways to address automation and its policies and regulations several years ago and we are working on numerous regulatory initiatives related to the future governance of automated technologies. NHTSA also continues to engage in frequent dialogue with innovators to ensure that our safety concerns are incorporated in all stages of product development.

In closing, along with our state and local partners, NHTSA will continue to use all of its tools to support the safe development, deployment, and oversight of advanced vehicle technologies. Thank you and I look forward to answering any questions that you may have.

[The prepared statement of Dr. Owens follows:]

PREPARED STATEMENT OF DR. JAMES C. OWENS, ACTING ADMINISTRATOR,  
NATIONAL HIGHWAY TRAFFIC SAFETY ADMINISTRATION

Good morning, Chairman Wicker, Ranking Member Cantwell, and members of the Committee. I am James Owens, Acting Administrator of the National Highway Traffic Safety Administration (NHTSA). Thank you for inviting me to testify today on the subject of NHTSA's efforts, under the leadership of Secretary Chao, to facilitate the safe testing and deployment of advanced vehicle technologies, such as Automated Driving Systems (ADS).

Safety is the Department's and NHTSA's number one priority, and we are committed to reducing crashes, preventing death and serious injuries, and lowering the economic costs of roadway crashes. The agency works to enhance vehicle and highway safety by using the wide array of tools at our disposal.

First and foremost, everything at NHTSA begins with data: it drives our research, rulemakings, enforcement activities, and public education campaigns. We collect safety data that helps all NHTSA stakeholders better identify challenges and opportunities for improvement.

We conduct research on emerging technologies, safety issues, and ways to improve the safety of current motor vehicles and motor vehicle equipment. We also research human behavior to identify ways to encourage people to make safer choices when driving and to avoid driving when drowsy or impaired.

Next, we promote investment in improving vehicular safety, first by establishing minimum safety standards for motor vehicles and motor vehicle equipment. We also evaluate and rate new vehicles through our New Car Assessment Program (NCAP), empowering consumers with safety information to help them select the best vehicles for their needs and—because consumers value safety—this creates market-based incentives for manufacturers to design safer vehicles to earn higher ratings.

At all times—including where our regulations have not adopted minimum standards—we stand ready with the full force of our enforcement tools to protect the public, to investigate potential safety issues, and to compel recalls when we find evidence of noncompliance or an unreasonable risk to safety. Our enforcement and defect authority is broad, and we do not hesitate to use it when we detect an unreasonable risk to public safety.

Finally, we partner with State and local officials, including law enforcement, to improve highway safety. We also work with many stakeholder partners to develop advertising campaigns to educate the public and encourage drivers to make safer choices, using resources provided to NHTSA by Congress.

Our efforts are having an impact—over the past 50 years, our Nation has seen a dramatic decline in crash fatality rates. In fact, the fatality rate in the early 1970s was about four times higher than today; the percentage of alcohol-impaired driving fatalities declined from nearly 50 percent of all fatalities in 1982 to less than 30 percent in 2018; and seat belt use has increased to about 90 percent nationwide.

We are proud that, through the adoption of improved safety features and other lifesaving technologies such as air bags and electronic stability control, new vehicles have become much safer. Recent data indicates that vehicle occupants have a significantly greater chance of surviving a serious crash if they are in a newer vehicle than in an older one. These technological improvements to vehicle safety are the combined result of NHTSA's safety standards and the voluntary investments that automakers have made in response to consumer demand for enhanced safety.

But we still have a long way to go. While we are pleased that fatalities on our Nation's roadways fell by 2.4 percent in 2018, or 913 fewer lives lost than in 2017, we also must remember that 36,560 people were killed in traffic crashes in 2018. That's more than 36,000 families who lost loved ones. Our efforts to reduce fatal crashes and serious injuries will continue by promoting additional investment and innovation to reduce the incidence of crashes, and to reduce the severity of crashes when they do occur.

One of the primary causes of serious crashes is human error. Our research indicates that four behavioral factors are involved in the vast majority of roadway fatalities: speeding, driving while impaired by drugs or alcohol, failing to wear seatbelts, and driving while distracted. NHTSA works closely with our State and local partners on high-visibility enforcement and advertising campaigns to target these behaviors. Our efforts have helped to increase the use of seat belts and reduce the number of impairment-related crashes.

In addition to our work with State and local partners, we also believe that advanced technologies have the potential to make our roadways significantly safer. We have already seen technologies improve the occupant protection of vehicles, while crash avoidance technologies such as electronic stability control have avoided or mitigated thousands of crashes and saved thousands of lives over the past decade.

States are deploying technology for traffic safety using 75 megahertz in the 5.9 Gigahertz band set aside by the Federal Communications Commission. The purpose of this Safety Band is to keep a dedicated transportation safety communication channel. Now, new vehicle and infrastructure technology being developed here and elsewhere use this band to communicate between vehicles to stop them from crashing, and between vehicles and infrastructure such as traffic lights to smooth traffic flow. Toyota is planning to deploy this technology in Japan and Volkswagen in Europe. The commitment of airwaves for transportation use was—and still is—a prudent decision.

Today, many manufacturers are developing and rolling out new advanced driver assistance systems (ADAS) such as automatic emergency braking and lane keeping assistance, which can help drivers avoid crashes or help reduce the severity of crashes that do occur. We expect that these and other developing technologies will help reduce fatalities among pedestrians and other vulnerable road users, and the early data on the efficacy of these technologies are promising.

It is critical that the public understands a vital fact about current technologies: all vehicles sold to the public today require a driver to be fully attentive and cognitively engaged in the driving task at all times. This is true even if the car is equipped with any of the ADAS technologies currently on the market. While these ADAS technologies are improving and enhancing safety, they are not self-driving. Misusing driver assistance systems by failing to maintain control of the operation of the vehicle at all times can result in serious and even deadly crashes. Consumer education is an important tool in ensuring that ADAS technologies are used in a way that enhances safety.

In addition to driver assistance technologies, we are seeing significant investments in more advanced Automated Driving Systems (ADS) that might one day allow vehicles to drive themselves and thereby have the potential to greatly reduce the number of fatal crashes involving human error or poor choices. ADS technologies may also enhance mobility for underserved communities and reduce congestion on our crowded highways. These technologies are being developed today by many different innovators, and NHTSA is actively participating by maintaining a close dialogue with developers to ensure that our safety concerns, including concerns about the cybersecurity of vehicles, are incorporated into the product development process.

Together, ADAS and ADS technologies are part of a technological revolution in transportation that promises to change our most basic assumptions about what vehicles can do.

But as with any revolution, these developments also carry uncertainty. Advanced technologies may not always work as designed or advertised. Driving is an extremely complex task, and developers acknowledge there will be substantial challenges in getting ADSs ready for deployment. As a result, we are likely to see an extended period during which ADS-equipped vehicles are being tested and deployed, likely only on a limited basis. If the history of other vehicle technologies is any

guide, some versions of these technologies will work better than others. But let me assure you: along with our State and local partners, NHTSA will continue to use all of its tools to support the safe development, deployment, and oversight of advanced vehicle technologies.

My testimony today will elaborate on the tools NHTSA leverages to promote safety with respect to both ADAS and ADS technologies, including data and research, rulemaking, enforcement, and public education.

#### **Data and Research Tools**

A great deal of ADAS and ADS technology is still under development. Accordingly, many of NHTSA's current activities are focused on data collection and research to support updating and modernizing regulations for older technologies, and to support developing future test procedures for ADAS and ADS technologies. Some examples include: assessing the effectiveness of newer driver assistance systems, evaluating human interactions with ADS technology, studying the protection of occupants in alternative seating arrangements and orientations, and evaluating component and cybersecurity safety.

As we transition from traditional vehicles and those with limited ADAS features to ever increasing levels of automation, we will address the ability of drivers to assume control when necessary. In all but fully automated vehicles, which are not commercially available yet, driver readiness to resume control is critical to safety. NHTSA is currently engaged in human factors research to evaluate various methods for notifying and engaging the human driver as needed to maintain safe operation of the vehicle.

One of the most exciting promises of ADS technology is the potential to provide mobility options not previously afforded to people with physical, sensory, and/or cognitive disabilities. As an example, accessible ADS-equipped vehicles are expected to provide information through appropriate modes to interact with vehicle occupants. Research is also underway to explore the information needs of people with disabilities.

Vehicles that are fully automated will affect more than just their operators and occupants. We are researching how these vehicles influence and take into consideration the behavior of pedestrians, bicyclists, and other humans and vehicles using the roadway. This type of research is needed to understand human behavior in response to automation and the new challenges such interactions will bring.

NHTSA is working closely with industry partners to broadly implement cybersecurity best practices. NHTSA encourages greater utilization of the Automotive Information Sharing Analysis Center (Auto-ISAC), which continues to grow, adding several new members in 2018 and releasing seven Auto-ISAC Best Practices guides thus far. NHTSA is also working to update the agency's "Cybersecurity Best Practices for Modern Vehicles" document.

For the past few years, NHTSA and the Society of Automotive Engineers (SAE) International have conducted joint government/industry cybersecurity workshops to discuss how to address critical issues unique to the automotive industry. The agency, along with many other Federal agencies and industry partners, participated in the U.S. Department of Homeland Security's 2018 biennial exercise, Cyber Storm, and we are preparing now for the 2020 exercise.

Lastly, in coordination with the industry, NHTSA conducts and publishes innovative research into mitigation strategies, testing methods, system interfaces, and organizational preparedness that support the continuous improvement of cybersecurity of modern vehicles. Our researchers are in frequent contact with industry and developers to discuss their findings.

#### **Guidance and Rulemaking Tools**

In addition to advancing critical research, NHTSA works closely with the industry and technology companies to promote safety as innovators develop ADAS and ADS technology.

"Automated Driving Systems: A Vision for Safety 2.0" (ADS 2.0), which was issued in September 2017, improved and further refined a flexible, non-regulatory approach to ADS technology safety by supporting the automotive industry and key stakeholders, including State and local governments, as they further develop and design best practices for safe testing and deployment of ADS levels 3-5.

In October 2018, the U.S. DOT released "Preparing for the Future of Transportation: Automated Vehicles 3.0" (AV 3.0).<sup>1</sup> AV 3.0 builds on, but does not replace,

<sup>1</sup>For more information on the Department's AV activities, please see: <https://www.transportation.gov/AV>.

the voluntary guidance provided in ADS 2.0, expanding the scope to all surface on-road transportation systems. As with ADS 2.0, AV 3.0 was developed with input from a diverse group of stakeholders. And, of course, it is critical that the United States maintain its leadership in the area of advanced vehicle technologies, and the evidence indicates that we are succeeding. In fact, at the June 2019 United Nations World Forum for Harmonization of Vehicle Regulations (WP.29) meeting, the Contracting Parties approved a Framework Document to guide the future work of the United Nations on Automated Vehicles. The framework is modeled on ADS 2.0, and was drafted by NHTSA staff in close cooperation with Japan, China, and the European Union.

NHTSA and the U.S. DOT's guidance will evolve as technology does, with safety as the constant cornerstone of our policies and initiatives.

To help facilitate the development of advanced vehicle technologies, NHTSA uses its rulemaking tools to promote investment in improving vehicle safety. It establishes regulations to adopt minimum safety standards for motor vehicles, and minimum performance requirements for vehicles that are equipped with a specific technology.

Some of NHTSA's existing policies and regulations will require updating to address the innovative vehicle designs being introduced by ADS developers. Knowing this, NHTSA began exploring ways to address automation several years ago. Currently, NHTSA is working on numerous regulatory initiatives related to future governance of ADS technologies. Some of these initiatives seek comment on requirements that may not serve any safety purpose if applied to ADS-equipped vehicles and thus may unnecessarily increase their cost. Other initiatives address test procedure challenges introduced by some ADS-equipped vehicles.

Existing Federal Motor Vehicle Safety Standards (FMVSS) may present unintended and unnecessary barriers for future ADS vehicles without drivers. Historically, FMVSS have been based on the concept of a human driver operating the vehicle. With the introduction of ADS, the driving tasks will increasingly shift from humans to the system. The absence of a human driver creates opportunities for vehicle manufacturers to design new vehicle architectures that may remove driving controls, change seating configurations, and establish new interfaces for passengers in a manner consistent with safety. The agency is gathering information to support decisions about potential adaptation of regulations to address unnecessary barriers to such innovative designs while ensuring that these vehicles would have equivalent levels of safety and performance to systems and components covered by existing safety standards. NHTSA issued an Advance Notice of Proposed Rulemaking (ANPRM) on May 28, 2019, to seek comments on existing motor vehicle regulatory barriers in the crash avoidance standards to the introduction and certification of ADS.

We are also undertaking several actions to update the process by which industry may seek exemptions from regulatory requirements. By proposing improvements to the current exemption processes, we hope to facilitate testing and enhanced safety oversight by allowing a wider variety of entities to request exemptions to operate nonconforming vehicles on public roads for purposes of research and demonstrations. One NPRM, titled "Expansion of Temporary Exemption Program to Domestic Manufacturers for Research, Demonstrations, and Other Purposes," will propose new submission and reporting requirements for vehicles to be exempted, mirroring those applicable to exempted imported vehicles.<sup>2</sup> All such exemptions would require demonstration that the vehicles would have an equivalent level of safety to our existing standards.

### **Enforcement Tools**

All new vehicles, including ADS-equipped vehicles, must comply with existing FMVSS, and all motor vehicles and motor vehicle equipment are subject to NHTSA's broad and powerful safety defect authority. That means that defective vehicles and equipment must be recalled and repaired when the manufacturer or the agency determines that the vehicles or equipment present an unreasonable risk to safety. Manufacturers are required to notify NHTSA and owners of any safety-related defects and remedy those defects for free.

While NHTSA is committed to working with industry to foster innovation and remove unnecessary regulatory barriers to the development of advanced safety technologies, the agency's first and foremost priority is safety. As manufacturers develop and test advanced vehicle technologies, NHTSA will continue to engage in ongoing dialogue with innovators to ensure that our safety concerns are incorporated in product development, and we will also remain vigilant to ensure these innovative

<sup>2</sup>See <https://www.reginfo.gov/public/do/eAgendaViewRule?pubId=201904&RIN=2127-AM14>.

technologies do not pose an unreasonable risk to safety. As ever, the agency will not hesitate to use its enforcement authorities when it is necessary and appropriate to protect the safety of the traveling public.

#### **Public Education Tools**

NHTSA understands that realizing the lifesaving potential of advanced vehicle technologies will rely heavily on consumer acceptance, and so it is vital to build public confidence through education and outreach. We believe this is a crucial component to fostering transparency and understanding of these systems.

To promote public engagement and transparency around the testing and development of ADS technologies, the agency established the voluntary safety self-assessment (VSSA) as a mechanism for entities that are developing and testing ADSs to communicate how they are prioritizing safety. As companies release VSSAs, NHTSA creates links to these materials on its VSSA Disclosure Index website.<sup>3</sup> It has been our experience that most companies approach the agency before publishing VSSAs, and the agency stands ready to assist by providing technical feedback as the documents are developed.

Additionally, in order to promote transparent public engagement, when companies petition NHTSA for exemptions from any of the FMVSSs for testing or deployment of ADS-equipped vehicles, the agency issues a public Request for Comment to take into consideration public input before granting or denying a request. If it grants such a petition, the agency will decide what terms and conditions should be placed on the grant to promote public safety and provide data needed to carry out its regulatory and oversight responsibilities.

NHTSA is also planning to conduct additional consumer market research to help identify the most effective ways to communicate and educate consumers about the different levels of driving automation. These efforts will also further inform NHTSA's media campaigns to increase consumer familiarity with advanced vehicle technologies, inform outreach efforts at consumer events, and enhance public facing materials on NHTSA's website.

Finally, NHTSA announced it will be updating NCAP, the agency's premier consumer information program for evaluating and communicating vehicle safety performance to consumers through 5-star safety ratings. NCAP is a powerful tool for promoting safety advances in vehicles. This year marks NCAP's 40th anniversary, and as with any program that has withstood the test of time, it continues to evolve to best empower the public to make more informed purchasing decisions. NHTSA recently announced plans to begin proposing major upgrades to NCAP in 2020. The agency will accelerate NCAP modernization to keep pace with newer safety technologies and help create additional market-based incentives for automakers to continue to invest in life-saving vehicle technologies. These upgrades reflect the comments and feedback we received from last year's public meeting, and they are expected to include new technologies, new test procedures, updates to vehicle labeling, advancements in crash-test dummies, and continued consumer research to ensure NCAP's products are effectively meeting the public's need. The agency will also consider including newer technologies tied to pedestrian and bicyclist safety in NCAP. And because we know that consumers demand safety, NCAP modernization will continue to deploy market-based incentives and competitive pressure to drive further safety-enhancing innovation by industry.

#### **Conclusion**

Innovation is advancing rapidly in the automotive sector, and the development of these technologies promises to save lives and reduce injuries on our Nation's roads. NHTSA's work will continue to prioritize the safety of automobiles as they become more complex with more advanced and automated technologies. NHTSA will continue to engage industry, States, consumers, Congress, and other stakeholders to draft automated vehicle polices and regulations that position the United States as the world's leader in automated vehicle technology while fulfilling NHTSA's vital safety mission.

Again, thank you for the opportunity to testify before you today. I look forward to answering any of your questions and to continuing to work with you to save lives on America's roadways.

The CHAIRMAN. Thank you very much. Mr. Sumwalt, welcome back to the Committee.

<sup>3</sup>To view the VSSAs currently available, please visit: <https://www.nhtsa.gov/automated-driving-systems/voluntary-safety-self-assessment>.

**STATEMENT OF HON. ROBERT L. SUMWALT III, CHAIRMAN,  
NATIONAL TRANSPORTATION SAFETY BOARD**

Mr. SUMWALT. Thank you, Mr. Chairman, Ranking Member Cantwell, members of the Committee. Thank you for the opportunity to testify before you today regarding the NTSB's perspective of the safe testing and deployment of highly automated vehicles.

As you well know, each year over 36,000 lives are lost on our Nation's roadways. We see great potential in the ability of automated driving systems to prevent or mitigate many of these tragedies. These systems hold a promise to be safer than human drivers, but until that promise is realized, the testing and development of AV systems requires appropriate safeguards and close interaction between Federal agencies, state and local governments, and industry.

Yesterday, the NTSB met to determine the probable cause of a crash involving Uber's Advanced Technologies Group developmental automated driving system that struck and killed a pedestrian in Tempe, Arizona that occurred last year. There were technical, human, and organizational factors that led to this tragedy. The vehicle's automated driving system did not accurately detect the pedestrian crossing mid-block outside of a cross walk. The operator responsible for monitoring the automation was distracted by her cellphone and did not detect the pedestrian in time to prevent the crash. Uber Technologies' poor safety culture exhibited by a lack of risk assessment procedures and ineffective oversight of the vehicle operator was inadequate to ensure the safe testing of its AVs on public roads. And additionally, the Arizona Department of Transportation failed to perform sufficient oversight of AVs doing such testing.

As a result of this crash investigation, we made safety recommendations that will improve the safe testing and deployment of highly automated vehicles on our Nation's roadways. We recommended that NHTSA require entities that intend to test a developmental automated driving system on public roads, submit safety self-assessment reports. Such reports are currently voluntary. NHTSA's evaluation of these reports would provide a uniform minimum level of assessment that will aid states with AV testing.

States that have no or only minimal requirements related to AV testing can improve the safety of such testing by implementing a thorough application of review processes before granting testing permits. We issued recommendations to address these issues.

As we discuss how highly automated vehicles can be safely tested and deployed on our Nation's roadways, it is critical that regulators and policymakers recognize the risk associated with partial driving automation systems that are currently being sold to consumers and operated on our roadways today.

My written testimony provides details regarding our past and ongoing investigations into vehicles operating with partial automation. These investigations highlight the need for the Federal Government and industry to incorporate system safeguards that limit the use of AV control systems to those conditions for which they were designed and to develop system applications that more effectively sense the driver's level of engagement to ensure that they are supervising the AV control systems.

And finally, I must highlight the importance of event data recorders for improving the safety of AVs. As more automation is deployed, manufacturers, regulators and crash investigators all need specific detailed information to determine how the systems perform so that automation and safety can be improved. We've made recommendations to DOT and NHTSA in this area, which still require action.

Thank you again for the opportunity to testify. I look forward to your questions.

[The prepared statement of Mr. Sumwalt follows:]

PREPARED STATEMENT OF HON. ROBERT L. SUMWALT III, CHAIRMAN,  
NATIONAL TRANSPORTATION SAFETY BOARD

Good morning Chairman Wicker, Ranking Member Cantwell, and Members of the Committee. Thank you for inviting the National Transportation Safety Board (NTSB) to testify before you today.

The NTSB is an independent Federal agency charged by Congress with investigating every civil aviation accident in the United States and significant accidents in other modes of transportation—highway, rail, marine, and pipeline. We determine the probable cause of the accidents we investigate, and we issue safety recommendations aimed at preventing future accidents. In addition, we conduct special transportation safety studies and special investigations and coordinate the resources of the Federal government and other organizations to assist victims and their family members who have been impacted by major transportation disasters. The NTSB is not a regulatory agency—we do not promulgate operating standards, nor do we certify organizations, individuals, or equipment. The goal of our work is to foster safety improvements, through safety recommendations, for the traveling public.

Motor vehicle crashes are a leading cause of death and injuries in the United States. In 2018, 36,560 people lost their lives in crashes on our Nation's highways.<sup>1</sup> The large majority of these tragedies can be directly linked to human error. Humans make mistakes and bad decisions, such as driving while they are impaired, distracted, or fatigued. Automated vehicle (AV) and collision avoidance technology have the potential to reduce the number of crashes, injuries, and fatalities significantly.

Today I will discuss some of the lessons learned from NTSB crash investigations and recommendations regarding the safe testing and deployment of highly automated vehicles. A focus of my testimony will be an overview of the findings and recommendations of our recently completed investigation of a developmental automated driving system (ADS) that collided with, and killed, a pedestrian in Tempe, Arizona, on March 18, 2018.

While there is often a desire to jump directly to the end of the technological spectrum—highly automated “self-driving” vehicles—it is imperative that regulators and policy makers do not ignore the risks associated with partial driving automation systems currently being operated on our highways. I will provide an overview of NTSB crash investigations involving Tesla model vehicles operating with partial automation and related recommendations addressing the safe deployment of automated control systems.

#### **Automated Driving Systems**

The use of AV controls and systems is accelerating rapidly in all modes of transportation. We have monitored AV development and have a long history of calling for systems to assist the operator in performing the driving task. One of the main sources of confusion in discussions about AVs is the language used in the industry, and by researchers and regulators, compared to that used by the general public. Industry, regulators, and academics frequently use the six-level SAE automation taxonomy as a reference point when discussing vehicle capabilities and operator responsibilities.<sup>2</sup> However, the SAE automation levels may not be easily relatable to the general public. At the same time, the terms used by vehicle manufacturers to market their partial driving automation systems (SAE level 2) such as ProPilot (Nissan), Pilot Assist (Volvo), and Autopilot (Tesla)—can add to public confusion about

<sup>1</sup>NHTSA Traffic Safety Facts, 2018, Fatal Motor Vehicle Crashes Overview, DOT Hs 812 826, October 2019.

<sup>2</sup>SAE International Taxonomy and Definitions for Terms Related to Driving Automation Systems for On-Road Motor Vehicles, Recommended Practice J3016, June 2018.

the degree of automation in the production-level vehicles now available. Although the general public frequently uses “self-driving vehicle” to describe currently available vehicles, it is an incorrect portrayal of the capabilities of vehicles on the roads in the United States today.

In describing highly automated vehicles (SAE levels 3 to 5), SAE recommends the term “automated driving system.” The defining characteristic of an ADS is that the system takes full control of all aspects of the driving task. Although a geographical area, environmental conditions, or a human occupant’s availability may limit the domain where an ADS is operational, the system is responsible for controlling the vehicle and avoiding hazards in that domain. We recently completed our investigation of a fatal crash in Tempe, Arizona, involving an ADS-equipped vehicle and made recommendations regarding the testing and deployment of these systems.

### **Tempe, Arizona, Crash Investigation**

On March 18, 2018, at 9:58 p.m., an automated test vehicle, based on a modified 2017 Volvo XC90 sport utility vehicle (SUV), struck a pedestrian walking midblock across North Mill Avenue in Tempe, Arizona. The SUV was operated by the Advanced Technologies Group (ATG) of Uber Technologies, Inc., which had modified the vehicle with a proprietary developmental ADS. An operator occupied the driver’s seat of the SUV, which was being controlled by the ADS. As a result of the crash, the pedestrian sustained fatal injuries.

We determined that the probable cause of the crash was the failure of the vehicle operator to monitor the driving environment and the operation of the ADS because she was visually distracted throughout the trip by her personal cell phone. Contributing to the crash were the Uber ATG’s (1) inadequate safety risk-assessment procedures, (2) ineffective oversight of the vehicle operator, and (3) lack of adequate mechanisms for addressing the operator’s automation complacency—all a consequence of inadequate safety culture. Further factors contributing to the crash were (1) the impaired pedestrian’s crossing of North Mill Avenue outside a crosswalk, and (2) the Arizona Department of Transportation’s insufficient oversight of AV testing.

At the time of the crash, the Uber ATG had an inadequate safety culture, exhibited by inadequate safety risk-management procedures and safety policies, lack of oversight of vehicle operators, and lack of personnel with backgrounds in safety management systems. For example, we concluded that the Uber ATG’s deactivation of the Volvo forward collision warning and automatic emergency braking systems without replacing their full capabilities removed a layer of safety redundancy and increased the risks associated with testing ADSs on public roads.

Although the ATG has made safety improvements in organizational, operational, and technical areas, we remain concerned regarding the safety culture of the numerous other ADS developers who are conducting similar testing.

Furthermore, a manufacturer is not the only entity with a role in ensuring the safe testing of AVs on public roads. To establish a robust safety framework, it is necessary to involve Federal agencies, which can establish and mandate ADS performance standards, and the states, which traditionally regulate drivers and vehicle operation on public roads. During our review of the role of Federal and state oversight, we identified the need for improved safety risk-management requirements for testing ADS on public roads.

### **Federal Oversight**

We see enormous potential in the ability of ADS to mitigate or prevent crashes on our roadways. A promise of the upcoming ADSs is that such systems will be safer than a human driver. Until that promise is realized, the testing of developmental ADS—with all its expected failures and limitations—requires appropriate safeguards when conducted on public roads. Unfortunately, there has been an absence of safety regulations and Federal guidance regarding how to adequately evaluate an ADS, which has prompted some states to develop their own requirements for AV testing.

Although the National Highway Traffic Safety Administration (NHTSA) has published three iterations of AV guidance, it provides insufficient instructions on how ADS developers should accomplish the safety goals of the 12 ADS safety elements—for example, training vehicle operators, ensuring oversight, and evaluating whether an ADS has reached a level of safety functionality.<sup>3</sup> More limiting aspects of the pol-

<sup>3</sup>See NHTSA 2016 Federal Automated Vehicle Policy—Accelerating the Next Revolution in Roadway Safety; NHTSA 2017 Automated Driving System 2.0: A Vision for Safety; and NHTSA 2018 Preparing for the Future of Transportation: Automated Vehicles 3.0. The 12 safety elements described in ADS 2.0 are: system safety, operational design domain, object event detection



icy pertain to (1) the absence of a NHTSA process for evaluating the adequacy of a safety self-assessment report, and (2) the lack of a mandatory submission requirement.

The shortcomings of the policy are exacerbated by the lack of assessment procedures and the difficulties in their development. For example, one of the 12 safety areas is “object and event detection and response,” pertaining to the capability of an ADS to detect, classify, and respond to objects and events in the environment. In this regard, we understand the difficulties in developing a “vision test” or standardized metric for assessing the perception of an ADS. In another of the 12 safety elements of its automated vehicle policy, human-machine interface, NHTSA addresses the need for monitoring driver engagement. NHTSA guidelines states, “entities are encouraged to consider whether it is reasonable and appropriate to incorporate driver engagement monitoring.” Because of the complexity of assessing all the relevant safety elements, to determine if sufficient safeguards exist for the testing and deployment of ADSs, a holistic assessment is needed, particularly when performance metrics may not exist.

The traditional division of oversight, in which NHTSA controls vehicle safety and the states monitor drivers, may not be easily applicable to developmental automated test vehicles. It might not be immediately apparent who controls the vehicle, or whether vehicle control and supervision is shared between the computer (the vehicle) and the human operator. A lack of appropriate policy from NHTSA and the states leaves the public vulnerable to potentially unsafe testing practices. To ensure that testing of AVs on public roads is conducted with minimal safety risk, meaningful action from both NHTSA and the states is critical.

If the process of submission of safety self-assessment reports were mandatory and included a process for the ongoing evaluation by NHTSA, it could serve as a criterion for judging whether a manufacturer’s approach to ADS development and testing met the minimal intent of the 12 ADS safety elements. NHTSA’s evaluation of a safety plan could also provide a minimum safeguard for the testing of developmental ADSs on public roads. Furthermore, assessment by NHTSA would provide important support to states when evaluating the appropriateness of a developer’s approach to the testing AVs.

As an outcome of the Tempe, Arizona, investigation, we recommended that NHTSA require entities who are testing or who intend to test a developmental ADS on public roads to submit a safety self-assessment report to the agency. We also recommended that NHTSA establish a process for evaluating the safety self-assessment report and determine whether the plans include appropriate safeguards for testing a developmental ADS on public roads, including adequate monitoring of vehicle operator engagement, if applicable.

#### **State Oversight and Legislation**

In the absence of Federal ADS safety standards or specific ADS assessment protocols, many states have begun legislating requirements for AV testing. The development of state-based requirements could be attributed to the concerns of many states about the safety risk of introducing ADS-equipped vehicles on public roads. The requirements vary. Some states, such as Arizona, impose minimal restrictions. Other states have established requirements that include a more in-depth application and review process. In the Tempe crash investigation, we determined that Arizona’s lack of a safety-focused application-approval process for ADS testing at the time of the crash, and its inaction in developing such a process following the crash, demonstrate the state’s shortcomings in improving the safety of ADS testing and safeguarding the public.

Currently, 21 states lack regulations pertaining to ADS testing. Although 29 states have some type of ADS-related policy, the requirements for testing vary considerably. Furthermore, the existence of a regulation is not a sure indication of a comprehensive and safety-driven ADS testing policy. In fact, Arizona was one of the 29 states that had some form of regulation pertaining to ADS testing, but, as stated previously, the safety application approval process was lacking.

States that have no, or only minimal, requirements related to AV testing can improve the safety of such testing by implementing a thorough application and review process before granting testing permits. The American Association of Motor Vehicle Administrators (AAMVA) has developed numerous model programs for motor vehicle administration, law enforcement, and highway safety in general. In May 2018, AAMVA published *Jurisdictional Guidelines for the Safe Testing and Deployment of*

---

and response, fallback (minimal risk condition), validation methods, human-machine interface, vehicle cybersecurity, crashworthiness, post-crash ADS behavior, data recording, consumer education and training, and federal/state/local laws.

*Highly Automated Vehicles.* Although the guidance contains elements of ADS testing, the AAMVA document lacked specific guidance for developers on how to accomplish the included recommendations. The guidance did include a very important element—the need for jurisdictions to identify a lead agency and establish an AV committee to develop strategies for addressing AV testing. However, the guidance does not include recommendations requiring ADS developers to submit a safety plan and for the state’s AV committee to review and approve such a plan.

Because states would benefit from adopting regulations that require a thorough review of ADS developers’ safety plans, including methods of risk management, we recommended that AAMVA encourage states to (1) require developers to submit an application for testing ADS-equipped vehicles that, at a minimum, details a plan to manage the risk associated with crashes and operator inattentiveness and establish countermeasures to prevent crashes or mitigate crash severity within the ADS testing parameters, and (2) establish a task group of experts to evaluate the application before granting a testing permit. Similar recommendations were also issued to the state of Arizona.

### **Partial Driving Automation System Safety**

Although much attention and Federal effort has been focused on highly automated SAE Level 3–5 vehicles, of equal and more immediate concern should be the current deployment of partial driving automation systems on our Nation’s highways. Between May 2016 and March 2019, we investigated four crashes—three resulting in fatal injuries—involving Tesla model vehicles with Autopilot engaged.<sup>4</sup> When Autopilot is activated and multiple subsystems, like traffic aware cruise control (TACC) and Autosteer, are combined to provide both lateral and longitudinal vehicle motion control, the system is considered an SAE Level 2 partial driving automation system. These Level 2 systems are considered by NHTSA to be advanced driver assistance systems.

Following our investigation of the March 2016 fatal crash involving a Tesla Model S 70D in Williston, Florida, we issued several safety recommendations aimed at preventing similar crashes involving vehicles operating with partial driving automation systems.<sup>5</sup> A few important safety issues identified in the Williston crash investigation included (1) limiting the operational design domains for partial driving automation systems, (2) monitoring an AV driver’s level of engagement, and (3) the need for more robust event data recorders for AVs.

#### *Operational Design Domain Restrictions*

SAE J3016 discusses the need for manufacturers to accurately describe AV features and clearly define the level of driving automation and its capabilities, but also its operational design domain—the conditions in which the driving automation system is intended to operate. Examples of such conditions include roadway type, geographic location, clear roadway markings, weather conditions, speed range, lighting conditions, and other manufacturer-defined system performance criteria or constraints. Tesla, for example outlined many operating conditions and limitations based upon the Autopilot partial automation system design, such as that it is (1) designed for use on highways with a center divider, (2) designed for areas with no cross traffic and clear lane markings, (3) not for use on city streets or where traffic conditions are constantly changing, (4) not for use on winding roads with sharp curves, and (5) not for use in inclement weather conditions with poor visibility.

Despite communicating to owners and drivers these operating conditions and limitations, Tesla Autopilot firmware does not restrict the system’s use based on functional road classification. Essentially, the system can be used on any roads with adequate lane markings. This situation allows a driver to activate driving automation systems at locations and under circumstances for which their use is not appropriate or safe, such as roadways with cross traffic. The Tesla Model S in the Williston, Florida, crash collided with a tractor-trailer combination vehicle crossing an uncontrolled intersection on a nonlimited access highway. Partial AV operation on nonlimited access highways presents challenges with the detection of crossing vehicles, pedestrian and bicycle traffic, and traffic controls at intersections, such as red traffic lights. As a result, we concluded that, if AV control systems do not automatically restrict their own operation to those conditions for which they were designed and are appropriate, the risk of driver misuse remains. We recommended that Tesla and other manufacturers of Level 2 automation:

<sup>4</sup> Investigations into two of the fatal crashes occurring in Delray Beach, Florida, and Mountain View, California, are ongoing, with final reports scheduled to be released in early 2020.

<sup>5</sup> *Collision Between a Car Operating with Automated Vehicle Control Systems and a Tractor-Semitrailer Truck Near Williston, Florida, May 7, 2016*, NTSB/HAR–17/02.

Incorporate system safeguards that limit the use of automated vehicle control systems to those conditions for which they were designed. (H-17-41)

Five automobile manufacturers responded to this recommendation with steps they were taking to mitigate operation under conditions for which they were designed. Tesla, however, advised us that operational design limits are not applicable to Level 2 driver assist systems, such as Autopilot, because the driver determines the acceptable operating environment.<sup>6</sup>

Tesla vehicles continue to be involved in crashes with Autopilot engaged in operating areas outside the intended roadway operational design domain. In March 2019, in Delray Beach, Florida, a fatal crash involving a 2019 Tesla Model 3 occurred under circumstances very similar to the Williston, Florida, crash.<sup>7</sup> The Delray Beach highway operating environment, like the cross-traffic conditions in Williston, was outside the Tesla Autopilot system's operational design domain.

Today's Level 2 partial driving automation systems can assess the vehicle's location and current roadway type or classification, and determine whether the roadway is appropriate to the system's operational design domain. Following the Williston crash, we made a recommendation to NHTSA to address this vital safety concern. We recommended that NHTSA:

Develop a method to verify that manufacturers of vehicles equipped with Level 2 vehicle automation systems incorporate system safeguards that limit the use of automated vehicle control systems to those conditions for which they were designed. (H-17-38)

In response to Safety Recommendation H-17-38, NHTSA wrote the following: The agency has no current plans to develop a specific method to verify manufacturers of vehicles equipped with Level 2 systems incorporate safeguards limiting the use of automated vehicle control systems to those conditions for which they were designed. Instead, if NHTSA identifies a safety-related defect trend in design or performance of a system, or identifies through its research or otherwise, any incidents in which a system did not perform as designed, it would exercise its authority as appropriate.

The current status of this safety recommendation is "Open—Unacceptable Response." We believe that NHTSA's reactive, rather than proactive, safety position is misguided, and the agency should take immediate action to verify that manufacturers are incorporating operational domain design safeguards into their systems.

#### *Monitoring an AV Driver's Level of Engagement*

Based on system design, in an SAE-defined Level 2 partial automation system, it is the driver's responsibility to monitor the automation, maintain situational awareness of traffic conditions, understand the limitations of the automation, and be available to intervene and take over for the partial automation system at any time. In practice, however, drivers are poor at monitoring automation and do not perform well on tasks requiring passive vigilance. Research shows that drivers often become disengaged from the driving task, both for momentary and prolonged periods during automated phases of driving.

In the Williston, Florida, crash, we found that the driver was disengaged from supervising the Autopilot partial automation. Tesla assesses the driver's level of engagement by monitoring driver interaction with the steering wheel through changes in steering wheel torque. In the Williston accident, when Autopilot was active prior to the crash, the system detected that the driver applied steering wheel torque only 2 percent of the time. Because Tesla uses steering wheel torque as a metric of driver engagement, the low percentage of driver applied torque in the Williston crash indicated a highly disengaged driver. This measure of driver engagement, however, is misleading. Because driving is a highly visual task, a driver's touch or torque of the steering wheel may not accurately indicate that he or she is fully engaged with the driving task. Simply checking whether the driver has placed a hand on the steering wheel gives little indication of where the driver is focusing his or her attention.

Following our Williston, investigation, we concluded that the way the Tesla Autopilot system monitored and responded to the driver's interaction with the steering wheel was not an effective method of ensuring driver engagement. As a result, we recommended that six manufacturers of vehicles equipped with Level 2 driving automation systems:

<sup>6</sup>Tesla provided this response during NTSB's ongoing investigation of the Mountain View, CA crash.

<sup>7</sup>See Delray Beach Highway Preliminary Report (HWY19FH008)

Develop applications to more effectively sense the driver’s level of engagement and alert the driver when engagement is lacking while automated vehicle control systems are in use. (H–17–42)

In response to Safety Recommendation H–17–42, five of the six manufacturers responded with actions they were taking to monitor a driver’s level of engagement. Tesla was the only manufacturer that did not officially respond. Because the operational design of partial driving automation systems requires an attentive driver as an integral system element, we will continue to advocate for manufacturers’ improved monitoring of driver’s level of engagement while supervising automation.

#### *Event Data Recorders for Automated Vehicles*

Title 49 *CFR* Part 563 sets forth requirements for data elements, data capture and format, data retrieval, and data crash survivability for event data recorders (EDRs) installed in light vehicles manufactured on or after September 1, 2012.<sup>8</sup> The regulation did not mandate the installation of EDRs in light vehicles; rather, if the vehicle manufacturer chose to install an EDR, the regulation defines the format and specifies the requirements for providing commercially available tools and the methods for retrieving data from the EDR in the event of a crash.

On December 13, 2012, NHTSA issued a notice of proposed rulemaking (NPRM) that proposed a new Federal Motor Vehicle Safety Standard (FMVSS) mandating that an EDR that meets 49 *CFR* Part 563 requirements be installed on most light vehicles. On February 8, 2019, NHTSA withdrew the NPRM because the agency determined that a mandate was not necessary. NHTSA’s internal analysis showed that, for model year 2017, 99.6 percent of new light vehicles sold were equipped with EDRs that met Part 563 requirements. NHTSA added that, given the near universal installation of EDRs in light vehicles, it no longer believed that the safety benefits of mandating EDRs justified the expenditure of limited agency resources.

In withdrawing the final rule, NHTSA said that it would continue its efforts to modernize and improve EDR regulations, including fulfilling the agency’s statutory mandate to promulgate regulations establishing an appropriate recording duration for EDR data to “provide accident investigators with vehicle-related information pertinent to crashes involving such motor vehicles.”<sup>9</sup> Because 49 *CFR* 563 data recording requirements codified more than a decade ago are very limited (only 15 data elements require reporting), NHTSA stated that it is actively investigating whether the agency should consider revising the data elements covered by Part 563 to account for advanced safety features.

In recent Tesla crash investigations, we were able to retrieve data from the EDR, but the EDR data recorded did not address the partial driving automation system’s activation or engagement. As a result, we used other proprietary manufacturer data to interpret the automation system’s functionality, but this type of data is not available on many vehicles operating with these systems today. Further, there are currently no commercially available tools for an independently retrieving and reviewing any non-EDR vehicle data, and other manufacturers of vehicles with driving automation systems control access to the postcrash proprietary information associated with their vehicles.

As more manufacturers deploy driving automation systems on their vehicles, to improve system safety, it will be necessary to develop detailed information about how the active safety systems performed during, and how drivers responded to, a crash sequence. Manufacturers, regulators, and crash investigators all need specific data in the event of a system malfunction or crash. Recorded data can be used to improve the automated systems and to understand situations that may not have been considered in the original designs. NTSB investigators need effective event data to conduct valid and productive investigations involving vehicles using AV control systems. Further, data are needed to distinguish between automated control actions and driver control actions.

Following the Williston crash, we made a recommendation to the U.S. Department of Transportation (DOT) regarding the need to define data parameters necessary to understand AV control systems and two recommendations to NHTSA to define a standard reporting format and to require manufacturers equipped with

<sup>8</sup>The EDR requirements apply to “light vehicles” required to have frontal airbags—those with a gross vehicle weight rating of 3,855 kilograms (8,500 pounds) or less and an unloaded vehicle weight of 2,495 kilograms (5,500 pounds) or less.

<sup>9</sup>See the Fixing America’s Surface Transportation (FAST) Act Public Law 114–94 (Dec. 4, 2015) section 24303.

driving automation systems to report incidents, crashes, and vehicle miles operated with the systems enabled.<sup>10</sup>

To the DOT:

Define the data parameters needed to understand the automated vehicle control systems involved in a crash. The parameters must reflect the vehicle's control status and the frequency and duration of control actions to adequately characterize driver and vehicle performance before and during a crash. (H-17-37)

To NHTSA:

Use the data parameters defined by the U.S. Department of Transportation in response to Safety Recommendation H-17-37 as a benchmark for new vehicles equipped with automated vehicle control systems so that they capture data that reflect the vehicle's control status and the frequency and duration of control actions needed to adequately characterize driver and vehicle performance before and during a crash; the captured data should be readily available to, at a minimum, National Transportation Safety Board investigators and National Highway Traffic Safety Administration regulators. (H-17-39)

Define a standard format for reporting automated vehicle control data and require manufacturers of vehicles equipped with automated vehicle control systems to report incidents, crashes, and vehicle miles operated with such systems enabled. (H-17-40)

In response to these recommendations, NHTSA has communicated with SAE International about developing industry standards, but explained the following:

Manufacturers are not currently required to enable vehicles to record data from usage of driving automation systems (SAE levels 1-2) or operation of such systems during crash triggered events. The ability for traditional vehicle manufacturers and other stakeholders to report on automated technology system use and its operation during incidents and crashes is highly dependent on each vehicle's specific recording and downloading technology.

Additionally, NHTSA stated that it believes developing recording requirements is best accomplished through voluntary compliance until industry consensus on standard data elements can be established.<sup>11</sup>

It is unlikely that crash investigators and regulators will fully understand the causal factors in a crash without easily accessible data from driving automation systems; therefore, we will continue to advocate action on these safety recommendations.

### **Conclusion**

Thank you again for the opportunity to be here today to discuss highly automated vehicles and some initial steps that can be taken by the DOT and states to advance the safe testing and deployment of automated driving systems. I will be happy to answer any questions.

The CHAIRMAN. Thank you to all three, three witnesses.

Senator Cantwell and I have decided that because of the leadership of Senator Thune and Senator Peters on this issue we'll let them go first in terms of questions. So the Chair recognizes Senator Thune for so much time as he may consume.

### **STATEMENT OF HON. JOHN THUNE, U.S. SENATOR FROM SOUTH DAKOTA**

Senator THUNE. Thank you Mr. Chairman. And thank you for your continued support of this critical legislative initiative. Automated vehicles have potential to drastically improve the safety of our Nation's roads and that's why I remain committed to working with Senator Peters, with this Committee, and with the House En-

<sup>10</sup>The current status of safety recommendation H-17-37 is "Open—Initial Response Received." H-17-39 and -40 are both classified "Open—Acceptable Response."

<sup>11</sup>NTSB experience with crashes involving different levels of driving automation shows that the amount and availability of recorded data varies widely among manufacturers.

ergy and Commerce Committee to develop a legislative framework for automated vehicles.

Similar to legislative efforts last year, any AV legislation developed in this Congress should ensure that the traditional roles of Federal and state regulators are preserved, build on NHTSA's current efforts to address incompatible regulatory requirements that were not written with AVs in mind and enhancing NHTSA's visibility to expand testing and grant exemptions where existing requirements may inhibit safety innovations.

Together these provisions will encourage the development of advanced solutions to improve vehicle safety, while providing important data that will inform the development of a safe and nationally consistent regulatory framework for AVs. I look forward to continued work on this effort to harness the safety, quality of life, and economic benefits of this critical emerging technology.

Mr. Szabat, the Department of Transportation has made important strides already with respect to testing and deploying automated vehicles, including the publication of comprehensive guidance like AV 3.0. As Congress considers AV legislation, how can we best build upon the Department's efforts to encourage the safe and efficient integration of these vehicles into the Nation's transportation system?

Mr. SZABAT. Senator Thune thank you for that question, which kind of gets to the heart of our next steps of what we do with autonomous vehicles.

In our AV 3.0 guidance, we refer to interoperability as that relationship—the Federal relationship between the states and local governments on one hand and the Federal Government on the other. And you're exactly right that one of the emerging issues that we have is how do we better define those relationships, especially in this period where we're trying to mix increasing use of autonomous vehicles with existing vehicles that are human driver controlled and human driven.

So I would just suggest two things for the Committee's consideration. One is, you know, the message that we hear loud and clear from the state and local governments is work with us. Do not impose upon us. So what that means for us, for Dr. Owens and NHTSA on the regulatory side or on the legislative front, to try to ensure that what we do, we do it in coordination with them, as opposed to a top down approach.

And the second point I think, which ties to the first, from our perspective, would be flexibility in legislation. As Mr. Sumwalt mentioned in his testimony, this is an emerging technology whether you have voluntary or mandatory standards or what those standards will be, they're going to have to evolve over time as the technologies evolve. So as you address these issues of from the legislative side, from a statutory side, we'd ask you to please ensure that we—and our state and local partners, have the flexibility we need to ensure that the best technologies get adapted as quickly as possible.

Senator THUNE. South Dakota plays host to hundreds of thousands of visitors at the annual Sturgis Motorcycle Rally, which is home to over 114,000 registered motorcycles. As a result, motorcycle safety is a top priority. In developing a regulatory framework

for autonomous vehicles, can you speak to how other road users such as motorcycles are considered?

Mr. SZABAT. Thank you again, for the question Senator Thune. Secretary Chao likes to say that people are policy and if that's the case, motorcyclists are well-developed in the development of policy in the Department. We have a motorcycle clique in the Office of Policy in the Department and of the five outstanding Secretaries of Transportation that I've been honored to serve, one of whom—one of them, she was an avid Harley rider herself. So we have concerns for motorcycles in our blood as well.

As we look to bring automated systems and driver assistance systems into play with vehicles, I think most members, I believe, here are aware one of the key precepts that we have, and this goes back to AV 2.0 and 3.0, is that they have to be able to be integrated with other road users. And those other road users include of course, pedestrians and bicyclists but also drivers of non-automated vehicles, but especially including motorcyclist as well, and that will continue to be a priority of ours going forward.

Senator THUNE. Mr. Owens, Dr. Owens, I should say, you mentioned in your testimony that NHTSA intends to issue a proposed rulemaking to modify reporting and submission requirements for exemptions. How do you believe the proposed changes will improve the exemption process, particularly for the unique circumstances associated with AVs while still maintaining the highest level of safety?

And then let me just as a follow up to that ask a second question. Do you see areas where Congress can be helpful in expanding or improving the current exemption framework?

Dr. OWENS. Thank you, Senator Thune. So as you noted, we are currently working on updating and improving our exemptions approval process. We are receiving a number of petitions. We expect to receive quite a few more petitions in the next coming years regarding exemptions from the FMVSS for novel vehicle designs.

Let me start by noting that all vehicles today must comply with the FMVSS. If an autonomous driving system or a test vehicle is compliant with the FMVSS, there is no need for an exemption from the Department. We also will note that the FMVSS were developed in order to protect the occupants of vehicles. And so, we must proceed very carefully and cautiously when we're determining which exemptions we can amend or which standards—I'm sorry, we can amend in order to ensure that we are remaining consistent with safety.

Having said that, there are quite a few developers who are looking at novel vehicle designs and for those novel vehicle designs, our regulatory standards, the standards that we established years ago may stand as an unintended and possibly unnecessary barrier to regulatory development, to technological development. So we are looking to streamline our exemptions petition process so as to make it help us reach a conclusion more quickly.

You also asked the question about the number of exemptions. We have heard from a number of developers. As you know right now under the statute, we have the authority to grant an exemption of up to 2,500 vehicles per year, that is a fairly small number for vehicle manufacturers and we've heard from a number of manufac-

turers that that small number may not be enough to help them pay for the research and development that they incur in order to develop these novel vehicle designs.

So that in the future if we're given greater flexibility to grant more exemptions, a larger number of exemptions, potentially flexibility that would allow us, allow the agency to make a determination on a case-by-case basis which vehicles, which designs, you know, have a greater likelihood of safety, less likelihood of safety. And then, we can make a risk-based decision on the number of vehicles that may be exempted.

As we're hearing from industry, that potentially would be helpful for the ultimate development of this industry.

Senator THUNE. Thank you. And my time has expired Mr. Chairman, but for the record the second question about what role Congress might be—

The CHAIRMAN. Go ahead with that. It's OK.

Senator THUNE. Yes.

The CHAIRMAN. We're going to be very flexible with you and Senator Peters.

Senator THUNE. OK, thank you. Yes. The second question had to do with what, how you see Congress playing a role and what can we do as you look at expanding, improving the current exemption framework?

Dr. OWENS. Thank you, Senator. So as I noted there's a statutory cap right now of 2,500 vehicles per year that we can provide an exemption for. We're hearing from industry that that cap may be too small. In certain circumstances, it may be appropriate and consistent with safety for NHTSA to grant an exemption potentially that would be higher than that cap. That would require a statutory change.

Senator THUNE. All right. Thank you, Mr. Chairman.

The CHAIRMAN. Thank you. Thank you, Senator Thune. Senator Peters.

**STATEMENT OF HON. GARY PETERS,  
U.S. SENATOR FROM MICHIGAN**

Senator PETERS. Thank you Mr. Chairman, and I'd like to thank Chairman Wicker and Ranking Member Cantwell. Thank you for putting together this hearing and for your leadership on this issue as well. Senator Thune, it's great working with you on this issue and as I listened to your opening comments and your questions, it's clear we're very closely aligned on all of these issues and hopefully we'll be able to get some very important legislation across the line as quickly as possible.

I particularly appreciated Senator Thune's comments on motorcycles. I'm an avid motorcyclist and there's no question this will enhance the safety for motorcyclists. The number one reason for accidents is a car hitting a motorcyclist pulling out in front, situational awareness with these technologies will save lives of motorcyclists all across the country, as well as lives in auto accidents.

This is without question, probably the most transformative technology in the auto industry since the first car came off of the assembly line. And we know what happened at the beginning of the



1900s when that happened and the transformational impacts throughout our economy and our society.

That's what's going to happen with the deployment of self-driving cars. Safety first and foremost is important and it has to be our focus. We've already heard this statistics, all of you have mentioned nearly 40,000 people die on our highways and that's why I also, as we are leaning into this and Senator Thune and I and all the stakeholders are leaning into having thoughtful approach to this. We also understand that delay should not be an option. This debate is not being held in a vacuum. This debate is happening while nearly a hundred people die every single day on our highways.

Today a hundred—roughly a hundred folks will die on our highways, not to mention the countless serious injuries, debilitating injuries. It's happening today. There should be public outrage about the number of people who die on our highways every single day. If we have these types of incidents of deaths in any other capacity, the American public says, why are you not doing this? Why are you not addressing this issue as fast and as quickly as possible? Obviously doing it in a thoughtful, deliberative way, but we need to move the ball as aggressively as we can.

And I'd say it's not just about public safety. We also know that our international competitors are racing to develop these technologies because of their transformational nature, particularly in their use of artificial intelligence and machine learning. What will be gained through the deployment of this technology will be game changing and every single industry and will allow for rapid advances in economic development. So it is imperative for us to act quickly from a safety perspective and from an economic competitive standpoint in the, in the world economy.

So my question for you Chairman Sumwalt, in your testimony you note that there has been an absence of safety regulations and Federal guidance. So my question to you, is it fair to say that the associated public safety risk in the absence of clear Federal rules or a Federal statutory framework to guide safe deployment and testing as it exists now, and we need to close that gap as quickly as possible?

Mr. SUMWALT. Senator Peters, I want to thank you and Senator Thune for your leadership as well as that of this committee in this very important area. And what we have found is that NHTSA currently has a voluntary requirement or voluntary guidelines for automated AV developers to submit a test plan safety assessment, self-assessment to NHTSA. NHTSA will presumably review it.

What we believe is that that loophole needs to be closed. We feel that NHTSA needs to actually require AV manufacturers to submit a safety self-assessment, NHTSA should then review it and assess it. That is something that we recommended yesterday. We feel that needs to be done.

Senator PETERS. Acting Administrator Owens, NHTSA has cautioned automakers about naming and marketing features in today's cars that give consumers the impression that they can basically let the cars drive on their own. In fact, the last hearing that we had, I think roughly 2 years ago we pushed pretty aggressively that the marketing of some of these technologies needs to reflect the actual

capabilities of those automobiles. And given the preponderance of high profile crashes that we have seen to-date that have involved driver assist that was marketed as autopilot. Do you think that NHTSA's warnings to industries have been adequate? Because autopilot seems to indicate a greater capability than actually exists.

Dr. OWENS. Thank you, Senator Peters. We have certainly been in close communication with all developers and we encourage all developers to make their consumers aware of the limits of their technology. If we determine that a nomenclature of a particular feature is inappropriate and contributes to the unsafe driving experience, we or the FTC could potentially take action. And we review these incidents very carefully.

We do note that these car companies, a number of car companies do try to market to their consumers and inform them of the limits and remind them that a driver—the driver needs to remain attentive and in control at all times. As I noted in my opening testimony, all vehicles in the United States today do require an operator to be in control or ready to take control. And the operator is responsible for the safe operation of that vehicle at all times.

NHTSA is interested in and empowering consumers with better information about these advanced features. We're seeing a whole galaxy of advanced safety features that are rolling out in the market today. We know these technologies are saving lives today. They're avoiding crashes. They're reducing the number of hospitalizations, that's all to the good. We have been facilitating and working with stakeholders, and we support the effort of stakeholders to develop a common nomenclature, a common naming system, so that we can better inform consumers about what they can expect from different features a vehicle might contain.

This is something that would go beyond just the trademarked, you know, names that particular manufacturers give to particular features, but rather would help a consumer understand if Vehicle A has this feature and Vehicle B have the same feature. They're providing the same technology even if they are given different names.

So this is an ongoing effort. We certainly support the continued efforts to provide a more uniform common harmonized naming system so that consumers won't be confused. And hopefully, that will also assist consumers in making decisions about which vehicles best suit their family's needs.

Senator PETERS. Well, I appreciate that and I think as you answered the question, I think it's also clear as to why it's important that we move very quickly, again, in a deliberate, thoughtful way to get to the level for the highly automated cars, Levels 4 and 5, because until you get to that point to have a requirement that a driver stay engaged and have complete situational awareness while the technology is piloting a car is a pretty big expectation. It's not what we do as human beings generally, we'll over rely on a technology and if it's not capable of actually carrying out all of the duties that you think it's going to carry out, that can lead to tragic consequences.

I think it's another argument as to why we need a Federal framework, why we had to have requirements that allow us to

move this as quickly as possible, again, in a deliberate, thoughtful way so that we get through that dangerous period from the Level 2, 3 into the Level 4 cars. So I appreciate your work on that area.

Mr. Chairman, if I could just ask one last question. The other issue that I think is important for us to deal with is the degree to which automation will change jobs and skills today and the future. And as a nation, I'm concerned that we're not doing enough to prepare for those jobs and with the automation of vehicles that will certainly have an impact on tomorrow's jobs. So Acting Under Secretary Szabat, your written testimony touches on the Department's study on labor force transformations associated with automation.

My Workforce Data Act with Senator Young, I would direct the Bureau of Labor Statistics to measure and track the impact of automation on workforce, not just the number of jobs created or eliminated, but also changes to the skills in demand as a result of adapting to these new technologies. So my question to you, sir, would skills focused data help inform the Department as you are considering the implications for the transportation workforce as a result of these new emerging technologies?

Mr. SZABAT. Thank you Senator for the question and for your focus on this important issue. The short answer to your question is yes, but would you like me to elaborate?

Senator PETERS. If you want to say a couple of words more words, that's fine, but I'm over time, so it'd be brief through.

Mr. SZABAT. OK. So to be brief we've allocated \$1.5 million to conduct a study on workforce impact. We're developing this report in coordination with the Departments of Commerce, Labor, and the Department of Health and Human Services. As you might expect when you do interagency coordination, these reports do take time to get out. But we're looking to get this out as quickly as we can because we also—as you do, we recognize the importance of the impact of this technology.

Senator PETERS. Great. Thank you for all of your testimony. Mr. Chairman, Ranking Member, thank you for your indulgence.

The CHAIRMAN. And thank you to Senator Thune and Senator Peters on this issue. We'll now revert to the 5-minute rule and the next round of questioning would go to Senator Fischer.

**STATEMENT OF HON. DEB FISCHER,  
U.S. SENATOR FROM NEBRASKA**

Senator FISCHER. Thank you, Mr. Chairman. I will take note of the rule. Mr. Szabat in DOT's AV 3.0 policy documents says, "no state or local government may enforce a law on the safety performance of a motor vehicle." It then states that Federal preemption "does not extend to state and local traffic laws, such as speed limits." The AV START Act passed by this Committee in the previous Congress included similar standards where the Federal Government maintained preemption regarding the design and performance of an AV.

Does DOT continue to agree with this policy that the Federal Government should oversee AV safety performance and states and localities should oversee traffic laws, licensing, insurance and liability?

Mr. SZABAT. Senator, thank you for the question. That kind of goes to the heart of the Federalist approach that we have to take an approach in trying to tackle this issue. The short answer is yes. If you have a moment for more, a longer answer I would defer to Dr. Owens to elaborate our position.

Senator FISCHER. Thank you, Dr. Owens.

Dr. OWENS. Thank you, Senator. So as you know, in our system of laws, we have a Federal state framework for the regulation of motor vehicles. NHTSA—when NHTSA establishes an equipment standard, a standard relating to the safe operation of equipment and the safe performance of equipment, that is exclusive, that is uniform across the country. And that continues to be necessary to ensure that we don't have a patchwork of potentially inconsistent regulations across the country, which could harm economic growth, which could create confusion and ultimately could negatively affect safety.

On the other hand, states will and do have the authority to ensure the safe operation of vehicles on their roads. If a vehicle exceeds the speed limit, if a vehicle is driven in a reckless manner from vehicles driven in a manner that can harm someone, we believe the state should and can and should retain the authority to exercise their law enforcement powers to ensure the safety of their citizens.

Senator FISCHER. The short answer is there is responsibilities at all levels of government.

Dr. OWENS. Yes, ma'am.

Senator FISCHER. Dr. Owens is, you know, AVs are becoming more sophisticated and they have the potential to take on more operational roles. We see this today with advanced driver assistance systems such as adaptive cruise control. You touched on this earlier, but I'd like to look at it from a consumer's point of view. What steps will NHTSA take to educate consumers on the technologies that are out there so that they can understand what an AV is capable of?

Dr. OWENS. Thank you, Senator. NHTSA is going to take a number of steps. First of all, we're supporting the effort by stakeholders to adopt a common nomenclature so that consumers can better understand what a feature is when it crosses across different makes and models. Right now, I believe there is some—we have a concern that there is some consumer confusion about what a particular feature can achieve.

In addition, we are conducting tests into ADAS systems and we, in fact this week, we're publishing a request for public comment in the *Federal Register* on proposed test procedures related to a number of ADAS systems establishing uniform test procedures that are objective, replicable. That will help us establish performance metrics that we can then communicate to consumers down the road about how these different systems are performing under different conditions. As part of that we, last month we announced that we're going to upgrade our new car assessment program that's NHTSA's five-star safety rating system. We're going to modernize and upgrade the system to include more advanced technologies, more crash avoidance technologies in this safety system, in the safety

rating to help empower consumers to make better informed decisions about which vehicles best suit their families' needs.

Senator FISCHER. In my first question, I brought it preemption and said there were differences in what the Federal Government, state government, local governments may do with regards to addressing the different responsibilities. When we look at autonomous vehicles, do you see a point where the Federal Government would possibly offer advice to states on how these vehicles should be regulated because of the differences in technologies involved in them?

Dr. OWENS. Thank you. Senator. We work closely with our state partners on vehicle testing, including advanced vehicle technologies. We stand ready to help guide them in this as this revolution, this technological revolution takes over.

Senator FISCHER. And again, with looking at consumers and the education of consumers.

Dr. OWENS. Yes ma'am. We stand ready to assist states in any way we can to help improve consumer awareness.

Senator FISCHER. OK. Thank you.

The CHAIRMAN. Thank you Senator Fisher. Senator Cantwell.

Senator CANTWELL. Thank you Mr. Chairman. Thank you to the witnesses, Chairman Sumwalt thank you for your recommendations yesterday and previous recommendations. I wanted Dr. Owens if I could just get a little more specificity, my colleague, Senator Peters started down this line, but I just want to make sure I'm clear about where NHTSA is today.

So one of the things that has been discussed before with NTSB is establishing minimum safety standards, particularly on Levels 1 and 2. So we're just talking about, you know, braking and steering systems and the automation. So, is NHTSA for establishing minimum safety standards?

Dr. OWENS. Thank you, Senator. So we will establish safety standards when we determine that the technology is proven and that the establishing a standard would be overall beneficial to the public safety.

As it stands right now, these technologies are still very much in the emerging phase. They're rolling out into the public and we're seeing a lot of safety benefits. But we also know that developers are continuing to make significant improvements and upgrades to those technologies today. If we establish standards too quickly, we run the risk of stymieing innovation. So we want to step back.

We want to let the innovation occur and the competition occur. And meanwhile, we continue to conduct research into how these technologies perform. And we regularly communicate with developers on our findings, and we learn from developers what technologies that they're pursuing, so we can better ensure that they're incorporating safety into their designs.

Senator CANTWELL. Mr. Sumwalt, what's wrong with having minimum safety standards now?

Mr. SUMWALT. That's a really good point. And we did, of course, yesterday's Board meeting really was focused on the testing of AV systems. So again, we do believe that NHTSA plays a key role in evaluating the assessment plans for the testing plans, which right now is just a voluntary standard.

Senator CANTWELL. Well, I'm going to get to that question next, but I'm assuming, Dr. Owens, that you do believe that we need to have, not voluntary, but mandatory standards and safety assessments?

Dr. OWENS. Thank you, Senator. So we established the safety assessment letter process as a voluntary process to encourage industry to better educate the public and to come forward with more information. I can tell you behind the scenes, the developers are in constant communication with our staff to discuss technical issues. We—those discussions help us better learn what technologies are being pursued and what the effectiveness of those technologies are. And that also helps us have better assurance that these that their product development is properly incorporating safety into their features. So we were—

Senator CANTWELL. So you believe in ignoring what NTSB has said about making them mandatory?

Dr. OWENS. So we're aware of the recommendation we've received from the NTSB. We will carefully evaluate it and get back to the NTSB as soon as we can.

Senator CANTWELL. And what about guidance on elements of advanced operations? What about giving guidance on elements of, you know, moving forward?

Dr. OWENS. Again, we will—we stand ready to review and assess and evaluate the recommendations from the NTSB and we'll get back to them as soon as we can.

Senator CANTWELL. Mr. Sumwalt or Mr. Szabat, do you want to jump in here?

Here's the problem. We are going to keep going, that's for sure. But this human interface and this technology needs some standards. It doesn't mean that they'll never change, but we are hearing from NTSB that if you even want to have a safe testing environment, you'll need to put some conditions on that. And so, this is about all of us getting together and I believe that should be in the most transparent way possible because that is how we're going to solve these solutions and keep moving forward.

So, Mr. Sumwalt?

Mr. SUMWALT. Ranking Member Cantwell, thank you. I'd love to weigh in on that. There are only 16 AV manufacturers who have submitted these voluntary guidance, these voluntary safety self-assessments. There has only been 16 out of maybe 80.

Senator CANTWELL. So Uber didn't do a self-assessment, is that correct?

Mr. SUMWALT. Correct, Uber did not submit a safety self-assessment report prior to the Tempe crash. However, afterward, they did submit a report to NHTSA. And the efficacy of these assessments ranges from anything that might look like a marketing brochure to somewhat more detailed. So whatever's working right now is not working as well as we believe it should.

Senator CANTWELL. I think that's the point. Look, we know as Senator Peters said, that the eventuality here is going to improve on the human interface, but at the same time you have to set some parameters of how it's going to move forward on testing. We've had people describe that they don't want to see them in their cul-de-sac because they're worried. We have to do better in this particular

area. I think on all of transportation, obviously this issue of automation, human factor response, testing needs a lot more attention.

Mr. SUMWALT. Well, and there's probably a rush to the market there. And so, the manufacturers are not going to be objective in evaluating their own safety assessment. So there, there needs to be a Federal look at these assessments to make sure that they're done properly. And that's why we issued those recommendations yesterday.

Senator CANTWELL. Thank you. Thank you Mr. Chairman.

The CHAIRMAN. Thank you Senator Cantwell. Senator Capito, then followed by Senator Schatz.

**STATEMENT OF HON. SHELLEY MOORE CAPITO,  
U.S. SENATOR FROM WEST VIRGINIA**

Senator CAPITO. Thank you, Mr. Chairman. Thank you all for being here today. Dr. Owens we've talked—we've heard a lot about safety and we've learned a lot about the testing. My understanding is that you have documented automated testing, active or planned in 34 states and the District of Columbia, is that correct?

Dr. OWENS. Yes. I believe that's the case.

Senator CAPITO. And for my state, West Virginia is one of the 16 states that's not among the testing. So is my assumption that the testing is in all different types of environments within the 34 states and how far advanced is this testing in a lot of these states? Or is it just in the planning phase?

Dr. OWENS. There is testing of various technologies at various levels of effectiveness going on across the country. It's concentrated largely in places that have more stable, controllable weather because you want to start with simpler conditions before you move to more challenging conditions with some of these new technologies.

Senator CAPITO. Right. Which leads me to one of the challenges, I think, in terms of as this advances rural America is—it depends on how rural you are, like, I guess your landscape and your weather and other things. So Mr. Szabat—did I say that correctly?

Mr. SZABAT. I answer to anything close Senator, Szabat.

Senator CAPITO. Szabat, sorry about that. In rural communities, you know, there are obviously transportation challenges just in general because tend to have higher poverty areas. There are no transport systems, transit systems in these areas. So there, there could be a whole economic model for rural America. So I'm interested in knowing what you think from a policy perspective would attract AV deployment into rural communities so that this can be, as it advances obviously it's not going to be in the beginning, but as it advances, states like mine could take advantage of that.

Mr. SZABAT. Senator, thank you for the question. And obviously, while I think that the Committee's jurisdiction, your interest of course matters of economic, our primary focus in the Department has to remain, you know, the safety issue.

Senator CAPITO. Right.

Mr. SZABAT. And there are huge safety issues as to why this matters to us. Only about 20 percent of the population lives in what are defined as rural areas, but 46 percent of the highway fatalities take place in rural areas. And almost half of the driving in rural

areas is taking place by people from urban areas transiting through a rural area. So this is—so the safety impacts in rural areas, both with autonomous vehicles and others, are something that matters to all Americans, not just to Americans in rural areas.

And second, to build on Dr. Owens response, you had asked what was being done in rural areas focus specifically. When we awarded our ADS demonstration grants, two of them were awarded specifically to focus on issues that are particular to rural areas. So the University of Iowa has a project aimed at deployments in non-urban environments and Texas A&M has a project titled, “Automated Vehicles for All,” which is also aimed at deploying AVs and areas with what we define as suboptimal road striping, signage, and quality, which are the kind of road conditions that you would find frequently in more rural areas.

Senator CAPITO. Yes. One of the issues when we brought this before the Committee before, too is the lack of connectivity in some areas and would that have impact, I’m sure that’s being investigated in the testing phase as well. Does anybody have a response to that? Dr. Owens.

Dr. OWENS. So connectivity is a struggle in rural areas. I mean, there’s rural broadband is certainly a problem.

Senator CAPITO. Right.

Dr. OWENS. And that’s beyond NHTSA’s remit. I will note though, that we’re also interested in connectivity for the ability to have communications from vehicle-to-vehicle or vehicle-to-infrastructure.

Senator CAPITO. Right.

Dr. OWENS. And there’s a 75 megahertz of spectrum that is set aside by the FCC for the use in this space. We call it the Safety Band and we’re hoping to preserve that 75 megahertz because it is now time, the technology is now there, that we can start deploying this potentially life-saving technology that will help rural as well as urban areas.

Senator CAPITO. OK. Last question. One of the discussions that we had when we passed our bill was about trucks, and obviously we remained focused on automobiles, is some of the testing that’s going on in some of these areas testing some of the truck technology or fleet kinds of applicability of AV technology in that area? Dr. Owens.

Dr. OWENS. Thank you Senator. There is absolutely testing that’s going on with large trucks right now. We’re conducting research into automatic emergency braking with respect to large trucks. We know that industry has been rolling out automatic emergency braking technologies and other crash avoidance technologies into large trucks. This is—there’s an opportunity here for us to reduce crashes with large trucks as well as passenger vehicles.

Senator CAPITO. Obviously on our high speed interstate highways. Like I’ll use 81, going down in through Virginia, which has a huge amount of truck traffic. The safer we can make that road and a lot of roads like that, I think that would be terrific. Thank you.

Dr. OWENS. Thank you.

The CHAIRMAN. Thank you Senator Capito. Senator Schatz.



**STATEMENT OF HON. BRIAN SCHATZ,  
U.S. SENATOR FROM HAWAII**

Senator SCHATZ. Thank you, Mr. Chairman. Thank you to all the testifiers. I want to start with Mr. Owens. NHTSA is tasked with making our roads safe for all users and you have some of the smartest safety engineers, but with backgrounds in automotive engineering, product safety, and mobility. But as we move into an AI environment, my basic question is what's your staffing plan? What's your capacity building plan as it relates to software engineers? And sort of looking under the hood of some of this AI to make sure that you're not watching a machine operate while what really ends up mattering from a safety perspective is code.

Dr. OWENS. Thank you Senator. And NHTSA absolutely has technicians on staff who have capabilities with software. We've been regulating software for a very long time as you know.

Senator SCHATZ. Sure. But is the, I guess the question is, I'm not asking you whether you have some capability, I'm asking whether or not you're going to have to ramp up like the rest of us in terms of the transformation of your agency to keep up with what's about to happen.

Dr. OWENS. Senator, as we encounter new challenges and opportunities in the industry, we do increase our resources. We also have the ability to increase our resources through contractors or working with other government agencies when we encounter issues that require specific technical expertise.

But we absolutely are committed to ensuring that our staff, our agency has a technical knowhow to address emerging issues.

Senator SCHATZ. Do you have a staffing plan for this?

Dr. OWENS. We have—yes, we have a staffing plan that addresses emerging issues. We have a very large research group within NHTSA and we ensure that we ensure that when we encounter a situation in which we identify that we need to have more expertise, we can get that expertise either through direct hiring or through contract or work with our government partners.

Senator SCHATZ. And you think you're going to do it by mostly by contracting or what? I mean, give me a little detail. I get that you have the capacity to do this. I get generally you have the flexibility to make adjustments. I'm asking you, however, do you see in the say next 16 to 18 months a need to hire more or contract for more software engineers and others who can analyze what's happening in this space?

Dr. OWENS. Senator, as we encounter new technologies, we make our staffing plans accordingly. We make sure we have the technical skills on staff to address these issues. If we—as these technologies are coming on board, we do address our resources to meet the needs.

Senator SCHATZ. OK. Mr. Sumwalt, it seems to me that safety depends partly on the ability for the operator, the operator of a vehicle to understand how this technology works. And my concern is specifically with respect to Tesla and the claims that they made about being able to go on full autopilot or have a fully self-driving car. My understanding is that A, that's not true. And B, your agency referred that to the FTC. Am I getting that right?

Mr. SUMWALT. Senator, thank you for the question. I don't think that it was us who referred it to the FTC. I could be wrong about that, but we have expressed concerns that I think, perhaps it may have been NHTSA that did that.

Senator SCHATZ. Was it NHTSA?

Dr. OWENS. We've had conversations with the FTC about a variety of emerging issues.

Senator SCHATZ. Again, I guess, the question I have because we don't want to get into someone's marketing claims. On the other hand, these are not marketing claims. These are safety claims. And as operators are trying to interpret what Levels 1 through 5 mean for them in terms of their responsibility as a driver, that they cross the Rubicon and they go into one of your agency's Federal jurisdiction, if not the Federal Trade Commission in terms of being deceptive to the users.

So where resides the stick? How do you go after a company that makes a false claim about how autonomous a vehicle is? Go ahead, Mr. Owens.

Dr. OWENS. Thank you, Senator. NHTSA has very broad defect authority. If we determine that any piece of motor vehicle equipment presents an unreasonable risk to safety, we do not hesitate to take action to ensure that it's subject to recall.

If we determine that a piece of equipment is so misunderstood by the public, that it is subject to significant misuse, that is something that we could potentially take action on.

Senator SCHATZ. Do I have your commitment, do we have your commitment to watch all of the claims by all of the auto manufacturers to ensure that there's some relationship between what they're claiming and reality? And that they take responsibility to educate their consumers?

Because what I don't want is for their marketing team and their general counsel to get together and just say, I think we can slide by this statutory requirement. They should have an affirmative obligation to make sure that the, that the purchaser and then the operator knows what in the world they're buying.

Dr. OWENS. We have many conversations with developers and, when we have concerns or when complaints are raised to us, we will investigate every such concern. Every such complaint.

If we determine that there is a problem, that it poses or is unreasonable as to safety, we will not hesitate to take action. Having said that, we also have conversations with the developers to help them better approach the market. So we do have a lot of conversations on these grounds.

Senator SCHATZ. One final question. Were these Tesla automobiles fully self-driving or did they provide full autopilot?

Dr. OWENS. There are no fully automated vehicles on our roads today. Every vehicle requires an operator to be in control or ready to take control.

Senator SCHATZ. Thank you.

The CHAIRMAN. Senator Udall, you are next.

**STATEMENT OF HON. TOM UDALL,  
U.S. SENATOR FROM NEW MEXICO**

Senator UDALL. Thank you very much Chairman Wicker and Ranking Member Cantwell. While I appreciate the potential benefits of autonomous vehicles, I remain concerned that humans will be used as test dummies instead of self-certification and deregulation. I want to see strong independent safety regulations from the agencies in front of us today.

The self-certification approach did not work out well for the Boeing 737 MAX 8 and now Boeing is paying the price. We should heed that lesson when it comes to finding out the best way to deploy autonomous vehicles. The public does not want their safety watchdogs getting too cozy with industry and the industry should welcome strong safety regulation as being in their long-term interest, being in their best long-term interest. While autonomous vehicle technology has safety potential, I want to also focus on witnesses and this Committee on Technology to eliminate drunk driving.

It's totally unacceptable that DUIs kill around 10,000 people every year in this country. Nearly 30 percent of all traffic fatalities. The Federal Government has been spending tens of millions of dollars on technology to stop drunk driving and it's time to get moving. Senator Rick Scott and I recently introduced the RIDE Act, which requires the National Highway Traffic Safety Administration to initiate and finalize a rulemaking to require technology to detect impaired drivers and stop them from driving in all new vehicles by 2024. Our bill does not require one specific technology, such as federally funded driver alcohol detection system for safety to be used, but allows any technology that keeps impaired drivers off the roads.

Dr. Owens, this is a question on DUI. This is an important question, particularly given the lack of movement on required rulemakings that are so long overdue. When this bill becomes law, do you believe that NHTSA has the necessary resources to work with the auto manufacturers and other interested parties to complete a rulemaking on DUI technology in a timely manner?

Dr. OWENS. Thank you, Senator. We take alcohol impaired driving very seriously at NHTSA. As you say, far too many of our citizens are being killed on our roads because drivers are driving in an impaired state. I've had the opportunity to visit the DADSS facility here in Virginia and their research facility up in Massachusetts over the past month and a half.

And I can tell you that the technologies are very promising, but they're not quite there yet. We certainly want to see these technologies get into cars as soon as possible, but we also need to make sure that when these technologies are rolled out and if there's a standard in place, that the technology is not premature because we also don't want to see a public backlash if there are too many people who have to walk home in the snow late at night because their vehicle accidentally said or had a mistaken false positive.

Having said that, we support the states who are demonstrating, who have pilot programs. We stand ready to support any state who wants to expand on these pilot programs. And we stand ready to do the research necessary. We have the resources necessary to do

the research to determine what technologies are effective and what technologies will not have too many false—so many false positives that we'll have a backlash.

Senator UDALL. I would just note that many states are moving very aggressively in this area and they're having very good success in terms of their numbers on bringing down the deaths from drinking and driving. I have a great deal of respect for the employees of NHTSA, but I'm concerned the agency does not have the resources necessary to perform essential oversight over the design, manufacture, and installation of impairment technology. I think this is a concern many of us share.

If NHTSA is enabled to push rules out in a timely manner, how can we be assured that the Agency can conduct adequate oversight, including over something as complex and unprecedented as self-driving cars?

Dr. OWENS. Thank you, Senator. We have the resources to oversee matters within our purview. We do an enormous amount of rulemaking, and an enormous amount of research underlying that rulemaking. All of our rules, when we proceed with standards, they're very technical standards. They require clear evidence and sound science in order for us to proceed. So we take our mission very seriously. And you know, we are with respect to impairment devices, impairment reduction devices—working closely, we are funding the effort, and we're closely overseeing the research efforts that are going on right now.

Senator UDALL. To both Chairman Sumwalt and Dr. Owens, after witnessing what happened with Boeing and the 737 MAX 8, are you personally confident that every manufacturer of autonomous vehicle technology would slow down or stop their deployment given the intense investor and market pressures to make money if they became internally aware of a safety problem?

Mr. SUMWALT. Thank you for that question Senator Udall. Yes, we found that there does need to be some level of oversight with respect to the testing of automated vehicles. We think that's important with respect to evaluating the safety of these operators, of these manufacturers.

Senator UDALL. Dr. Owens, do you have a brief comment?

Dr. OWENS. Yes, Senator. So we do exercise safety oversight over these developing vehicles. Any under the law, any manufacturer who discovers a safety problem has to make us aware. If they do not make us aware, they will be subject to penalties and civil action. We do not hesitate to take action. If we determine that any piece of motor vehicle equipment poses an unreasonable risk to safety, we can assure that it is recalled. This is an authority that exists whether or not we have a regulatory standard in place.

Senator UDALL. Thank you, Mr. Chairman.

The CHAIRMAN. Thank you Senator Udall. Senator Duckworth.

**STATEMENT OF HON. TAMMY DUCKWORTH,  
U.S. SENATOR FROM ILLINOIS**

Senator DUCKWORTH. Thank you, Mr. Chairman. As we sit here today, millions of Americans are getting ready to go start traveling next week for Thanksgiving. I hope everyone has a happy and a

very safe upcoming holiday season, especially during this high period of travel on our roadways.

Chairman Sumwalt and Secretary Szabat, it's good to see you both again. Dr. Owens as this is our first encounter, I'd like to invite you to my office in the upcoming weeks to discuss your new role and NHTSA's ongoing efforts.

Dr. OWENS. Thank you, Senator. I'd appreciate that.

Senator DUCKWORTH. Thank you. Mr. Chairman, I have three primary goals when it comes to autonomous vehicle legislation. First, and my top priority, is reducing risk on our roadways and one day eliminating traffic fatalities. While traffic deaths were down by 2.4 percent last year compared to 2017 there were still 36,560 fatalities on our roadways. That's roughly the entire population of Rock Island, Illinois in a single year.

During this same period, pedestrian deaths increased by more than 3 percent and bicycle deaths rose by more than 6 percent. Most of these incidents are result of driver error and AV technologies present an opportunity to address this variable. I applaud Senator Peters and Senator Thune for their leadership in developing the AV START Act in the 115th Congress. This effort focused this committee's attention on important and complex issues and I look forward to continuing these discussions over the coming weeks and months.

My second goal for autonomous vehicles is to expand and improve mobility options for the disability community. Far too often travel options with disabled individuals are limited in ways that non-disabled individuals take for granted. Autonomous vehicles could provide mobility opportunities never before imagined, and this is a critical component for any long-term legislative effort.

Third, I also want to make sure that we don't view AV policies exclusively through the keyhole of vehicles safety standards. We need to keep an eye on the impacts autonomous vehicles will have on our roadway infrastructure. Last year I included language in AV Start requiring DOT to study these issues and include a similar provision in the EPW Committee's highway bill in July.

Chairman Sumwalt, NTSB's recent AV-related investigations paint a clear picture that driver engagement played a significant role in some of these incidents. Several NTSB recommendations call on manufacturers and operators to improve a driver's level of engagement. Is that correct?

Mr. SUMWALT. Senator Duckworth, that's exactly correct.

Senator DUCKWORTH. Thank you. So Dr. Owens, Level Zero vehicles include technologies like automatic emergency braking, lane departure warning, but requires the driver to continue controlling the vehicle at all times. And meanwhile, a Level 5 vehicle theoretically could drive someone to and from a destination under reasonable conditions without anyone in the driver's seat. Does NHTSA certify a vehicle that is a Level 1 versus a Level 2, and so on?

Dr. OWENS. Senator, we do not certify the different levels of automation.

Senator DUCKWORTH. OK. So as Level 2 technologies inched toward Level 3 automation, I want to know more about NHTSA's plans to ensure consumers are fully prepared to drive or occupy these vehicles safely and effectively.

This morning NHTSA released a request for comment on draft research procedures to assess certain advanced driver assistance systems, like blind spot intervention, opposing traffic safety assist, and traffic jam assist. I have no idea what these mechanisms do for safety, but we seem to be creeping toward an over-reliance on technologies rather than improving driver engagement. I appreciate this RFC for research purposes, but I'm increasingly concerned that NHTSA is more focused on technology than on safety and on driver engagement.

Dr. Owens when we meet in my office, I'd like to follow up on this point including what steps DOT is taking to better understand advanced technologies to improve a vehicle's responsiveness from objects and people on the road.

Dr. OWENS. Thank you Senator, I'd be happy to discuss this with you further.

Senator DUCKWORTH. Thank you. Thank you Mr. Chairman and I yield back.

Senator BLUMENTHAL [presiding]. The Acting Chair recognizes Senator Tester.

**STATEMENT OF HON. JON TESTER,  
U.S. SENATOR FROM MONTANA**

Senator TESTER. I want to thank you Acting Chair for recognizing me and I want to thank the panel for being here today. I've got a number of questions that you're just going to have to educate me on and that is, is have you guys done any projections as to when Level 5 will occur? How many years out are we from Level 5 autonomous vehicles?

Dr. OWENS. Thank you, Senator. We have not done an official projection. It is several years, more than several years off before we're at Level 5. What we're finding both from our own research and what we're hearing from industry is that developing a fully autonomous vehicles in a complex surface driving environment is very hard. It's very difficult. It's more complicated and difficult than was anticipated several years ago.

So the technologies are continuing to be developed and improved, but they're not going to be here yet and they're not going to be here next year or the year after I would expect.

Senator TESTER. OK. I mean, your answer intimated to me that it may never be here.

Dr. OWENS. I would expect it's going to happen.

Senator TESTER. OK.

Dr. OWENS. It's just a question of when.

Senator TESTER. OK. Because I think the projection is important because then you know where the workload is. Five years?

Dr. OWENS. Senator, this is something where the technology is taking the lead, not the regulators. So when the technology is ready we'll be in a better position to know exactly what the time line is.

Senator TESTER. OK, I got you. So the question I have, because I come from a very rural frontier area and I heard one of you talk about 75 megahertz, I've got a couple of pickups that I can, they'll bounce down the road using sensors, cameras, whatever you want to call and pretty much keep you on the road most of the time. But

the question becomes with was fully autonomous. Is it, do you anticipate that the 75 megahertz is going to be a necessity for the fully autonomous vehicle? Is that what you're hearing from the folks that you're working with?

Mr. SZABAT. Senator thank you for the question because it is an important one for the eventual deployment and development of whether they're autonomous vehicles that are assisting drivers or autonomous vehicles operating by themselves.

Senator TESTER. Right.

Mr. SZABAT. So again, short answer again is yes.

Senator TESTER. It's going to be necessary.

Mr. SZABAT. Yes. And the question is, do you need exactly 75 megahertz?

Senator TESTER. Yes.

Mr. SZABAT. Can you do 55? Would we need 80 or 90?

Senator TESTER. Yes, I got you.

Mr. SZABAT. But there's some large section of spectrum that will be necessary.

Senator TESTER. And the other question I had was, is satellite able to do this?

Mr. SZABAT. So the way the way it's structured right now Senator, is it's not, it's not currently reliant on satellites. DSRC technology is more direct vehicle-to-infrastructure. However, the emerging technologies that we have such as CV2X would require cell tower or satellite type connections and so there's a potential that yes, it would require that going forward.

Senator TESTER. So, the problem we have here is that if 75 is necessary and I don't think we're a five or even 10 years out from having the kind of Internet necessary and that kind of cell service necessary to be able to support this, then what happens to that driver who's well-educated as everybody's talked about as what their car will do in the years, in the future. But they come to my house and the car isn't going to operate the way it does if you're in Chicago. How are they going to know about this stuff?

Dr. OWENS. Thank you, Senator. It's important to note that the way these technologies will work, is they will beam from one vehicle to another vehicle and you'll be able to tell each other, the two vehicles will be able to talk and tell each other where they are and where they're headed. So you don't need to have rural broadband.

Senator TESTER. Regardless if you have 75 megahertz, regardless of whether you have the service or not out there?

Dr. OWENS. The 75 megahertz was set aside for the public to use for intelligent transportation services by the FCC. That 75 megahertz is what the devices would use in the spectrum in order for the vehicles to talk to each other or to the infrastructure.

Senator TESTER. So they don't need cell towers? They don't need high speed Internet to make this work?

Dr. OWENS. They—my understanding is they do not need high speed Internet necessarily. What they need are the ability—the radios, the antenna—to talk to each other directly. It's almost like—

Senator TESTER. I got you. That's if I'm going to crash into the car ahead of me. What about keep it on the road?

Dr. OWENS. So these technologies are mostly designed right now to, look at—to reduce crashes or to help you talk to the infrastructure to turn the lights green.

Senator TESTER. But if you have a fully autonomous vehicle or even one that's mostly there, they're going to pretty much drive it for you. They're going to keep you between the white lines.

Dr. OWENS. Yes, Senator. But for the foreseeable future, we expect that once we start seeing fully autonomous vehicles on our roads, we'll have decades in which we will have human driven vehicles and fully autonomous vehicles.

Senator TESTER. I got you. The question is that, and I have no doubt about that, the question is what do you do when the service is not there? I got the talking between cars, but the service is not there to keep that car on the road. And I've been doing just fine driving between Bismarck and Fargo, but ain't doing very good driving between Great Falls on Havre, Montana.

Mr. SUMWALT. And Senator, I think you asked exactly the right question as, I think, as we transition beyond Level 4 to Level 5 service levels where you know, you're going to have a period where autonomous vehicles can operate only in certain environments. And it could be we're not in a position to project because this is where the technology has not yet played out. But it could be future technologies are so dependent on certain types of satellite communications that are not prevalent in rural areas that the Level 4 vehicles do not operate extensively in rural areas. And that'll be incumbent upon us to have a national policy of how we get them there.

Senator TESTER. So I would just tell you, you guys got a lot of work cut out for you because there's so many—there are so many factors. You've got a dead antelope laying on the road. I can see the car swerving over or potentially stopping, but if it swerves over and there's another car coming on a two lane highway. Now you've created a head on collision with AV. And so, you've got a lot of work cut out for you and I appreciate the Chairman and Ranking Member having this hearing and appreciate you guys being here.

The CHAIRMAN. Thank you Senator Tester. Senator Markey.

**STATEMENT OF HON. EDWARD MARKEY,  
U.S. SENATOR FROM MASSACHUSETTS**

Senator MARKEY. Thank you Mr. Chairman. As we debate the future of fully self-driving cars, we also need to focus on the present rollout of driver assistance features that are actually driver replacement technologies for some of our most basic tasks on the road. For example, Tesla markets its autopilot system as a driver assistance feature that allows a car to center itself in a lane and to offer speed changing cruise control and self-park. To make sure that drivers are still paying attention, Tesla requires them to keep their hands on the wheel while autopilot is active. Keep your hands on the wheel.

However, according to a recent report on NBC Boston, Tesla drivers have identified a variety of tricks to make autopilot believe they are focused on the road, even if they are literally asleep at the wheel. Alarming. You can go to YouTube right now and learn about some of these tricks. You can take a water bottle, take an orange and put it right into the steering wheel. And then that



tricks the system to believing that your hands are on the wheel. And then the car just drives as though it's a fully autonomous vehicle and not something that just human helped in the driving.

And NBC Boston reported that one driver actually used these tricks and fell asleep at the wheel while their car drove 14 miles on autopilot with a water bottle in the steering wheel or with an orange in the steering wheel. That's not safe. Somebody's going to die because they can go to YouTube as a driver, find a way to do this and then some innocent person on the street will wind up dead or a driver in another car will wind up dead.

So we can't entrust the lives of our drivers and everyone else on the road to a water bottle. And that's why I sent a letter to Tesla this week urging the company to fix the safety flaws that allow drivers to trick autopilot before any tragedies occur.

Dr. Owens, these videos are on YouTube right now. So NHTSA must know what is happening as well.

The CHAIRMAN. Let's put that letter in the record at this point.

Senator MARKEY. I asked unanimous consent to do that.

The CHAIRMAN. Without objection.

[Senator Markey's letter to Tesla is entered.]

EDWARD J. MARKEY  
MASSACHUSETTS

COMMITTEES:  
ENVIRONMENT AND PUBLIC WORKS  
FOREIGN RELATIONS  
RANKING MEMBER  
SUBCOMMITTEE ON EAST ASIA, THE PACIFIC,  
AND INTERNATIONAL CYBERSECURITY POLICY  
COMMERCE, SCIENCE, AND TRANSPORTATION  
RANKING MEMBER  
SUBCOMMITTEE ON SECURITY  
SMALL BUSINESS AND ENTREPRENEURSHIP  
CHAIRMAN  
U.S. SENATE CLIMATE CHANGE TASK FORCE

## United States Senate

SUITE SD-255  
DIRKSEN BUILDING  
WASHINGTON, DC 20510-2107  
202-224-2742

975 JFK FEDERAL BUILDING  
15 NEW SUBURBAN STREET  
BOSTON, MA 02203  
617-565-8519

222 MILLIKEN BOULEVARD, SUITE 312  
FALL RIVER, MA 02721  
508-677-0523

1550 MAIN STREET, 4TH FLOOR  
SPRINGFIELD, MA 01103  
413-785-4610

November 19, 2019

Elon Musk  
Co-Founder and CEO  
Tesla  
3500 Deer Creek Road  
Palo Alto, California 94304

Dear Mr. Musk:

I write to inquire about what actions Tesla is taking to prevent drivers from evading the safety features built into your cars' Autopilot system. According to a recent report, Tesla drivers have identified a variety of ways to circumvent the safety alerts and automatic shut-off feature that are designed to activate when a user of Autopilot is no longer paying attention to the road.<sup>1</sup> These techniques reveal inherent flaws in Tesla's Autopilot system that may pose a public safety danger and Tesla should quickly take action to address these risks before any tragedy occurs.

Currently, Tesla drivers can learn from online videos how to trick their Autopilot system into believing they are actively paying attention to the road even if they are asleep or otherwise unengaged.<sup>2</sup> These easily accessed techniques include strategically resting a driver's hand at the six o'clock position on the wheel, tying a weight to the wheel, and wedging a water bottle or an orange into the wheel.<sup>3</sup> In one alarming example that was the subject of a recent press report, a Tesla driver used one of these techniques and then fell asleep even while his car drove for fourteen miles on Autopilot without his attention.<sup>4</sup> Thankfully, no tragedy resulted from this specific incident, but I am deeply troubled by what could have happened if the car came across conditions that Tesla's Autopilot is not capable of addressing on its own — such as an intersection with a traffic light.<sup>5</sup>

This report illustrates why we must be cautious when deploying autonomous vehicle (AV) technologies on public roads. In response to a pedestrian fatality caused by an AV and driven by my concern with the need for safety on public roads, I wrote to Tesla in May 2018 to inquire

<sup>1</sup> Ryan Kath, *Tesla Owner Says He Fell Asleep Behind Wheel With Car in Autopilot Mode*, NBC Boston (Nov. 11, 2019), <https://www.nbcboston.com/investigations/Tesla-Owner-Talks-Sleeping-Car-Autopilot-Mode-564761842.html>.

<sup>2</sup> *Id.*

<sup>3</sup> *Id.*

<sup>4</sup> *Id.*

<sup>5</sup> *Id.*

about your company's safety protocols and practices while testing AV technology.<sup>6</sup> In your inadequate and unconcerned June 2018 response, Tesla failed to recognize the potential harm your Autopilot system could cause. Instead, Tesla ignored my questions about Autopilot's safety features and instead cited the Autopilot system itself as a robust safety feature.<sup>7</sup> Tesla's disregard for the importance of safety features and significant reliance on Autopilot makes the recent report about drivers evading your safeguards both unsurprising and troubling.

I believe that Tesla cannot rely on a single flawed system to protect its drivers and other users of our roadways. Instead, Tesla must take more robust action to prevent any harm before tragedy occurs. Accordingly, I respectfully request that, by December 6, 2019, you respond in writing to the following questions:

1. Does Tesla exhaustively test potential methods for evading Autopilot's safety features? If so, please describe your testing methods in detail. If not, why not?
2. Does Tesla track or otherwise monitor the online videos that drivers are posting to share tricks for circumventing Autopilot's safety features? If so, what does Tesla do with this information once discovered? If not, why not?
3. What actions is Tesla taking to upgrade the Autopilot system in Tesla cars currently on the road to address these now-known flaws? What action is Tesla taking to improve Autopilot for future models of Tesla cars before they are put on the market?
4. What safeguards beyond the Autopilot system is Tesla deploying, or considering deploying, to address the risks of AV technologies on public roads?

Thank you for your attention to this important matter. If you have any questions, please contact Eric Kashdan of my staff at [eric\\_kashdan@markey.senate.gov](mailto:eric_kashdan@markey.senate.gov).

Sincerely,

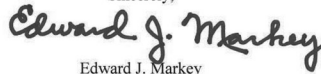

Edward J. Markey  
United States Senator

---

<sup>6</sup> Press Release, Senators Markey and Blumenthal Begin Investigation Into Safety Protocol and Practices for Driverless Car Testing on Public Roads (May 25, 2018), <https://www.markey.senate.gov/news/press-releases/senators-markey-and-blumenthal-begin-investigation-into-safety-protocol-and-practices-for-driverless-car-testing-on-public-roads>.

<sup>7</sup> Letter from Tesla to Senators Markey and Blumenthal Re: Testing Autonomous Vehicles on Public Roads (June 8, 2018), <https://www.markey.senate.gov/download/tesla-response>.

Senator MARKEY. So NHTSA must know what is happening if it's on YouTube. So tell me what NHTSA is doing, what you're telling Tesla to make sure that these safety issues are fixed and that these cars don't wind up killing people?

Dr. OWENS. Thank you, Senator Markey. It is unfortunate when drivers misuse their vehicles and engage in unsafe behaviors. This is the cause, as you know, of most serious crashes and fatalities in the United States.

Senator MARKEY. So what are you telling Tesla to do in order to fix this defect that can easily circumvent what the safety precautions are supposed to be? What are you telling Tesla to do?

Dr. OWENS. We are in close communication with Tesla on a variety of issues, a number of complaints.

Senator MARKEY. No, on this issue. What are you telling—what is NHTSA telling Tesla to do on this issue to fix it so that this kind of circumvention of the safety procedures doesn't wind up with somebody dying because of the way in which drivers can now use this technology? What are you telling them?

Dr. OWENS. Senator, I'd be happy to follow up with you on the specifics of this case. I will note that we've become aware that—

Senator MARKEY. So you have not, have you had any conversations with Tesla?

Dr. OWENS.—our technical staff has routine conversations with every—

Senator MARKEY. On this issue? On the issue of a water bottle able to take over a steering wheel and allow the driver just to go to sleep, have you had that conversation?

Dr. OWENS. I would have to get back to you on that.

Senator MARKEY. You don't know—I would urge you to do that very quickly because Tesla should disable autopilot until it finds the problem, until it fixes the problem, until it can assure consumers who don't own that vehicle, that they're safe on the roads or safe on the sidewalks from an accident occurring. Will you do that?

Dr. OWENS. Yes Senator, we will work with your staff and as I said, we're in communication with Tesla. I'll also note that—

Senator MARKEY. Yes, you're in touch with them. You're not in touch with them on this issue. That's my problem. This is something that you can go to YouTube right now, which is what I did to pull down this picture of how you can use a water bottle to take over a vehicle.

Dr. OWENS. I will make sure that we're in touch with Tesla about this specific issue.

Senator MARKEY. OK. Well, if you tell them to fix it or just disable that technology, that would be my advice to you. So I thank you Mr. Chairman.

The CHAIRMAN. Thank you Senator Markey.  
Senator Blumenthal.

**STATEMENT OF HON. RICHARD BLUMENTHAL,  
U.S. SENATOR FROM CONNECTICUT**

Senator BLUMENTHAL. Thank you Mr. Chairman. Let me pursue that very good line of questioning.

Mr. Sumwalt, in your testimony, you state that you offered recommendations to Tesla and other manufacturers after the fatal Tesla Model S crash in Williston, Florida. These were recommendations to incorporate system safeguards that limit the use of autonomous vehicle control systems to those conditions for which they were designed. Five auto manufacturers responded with steps to meet your recommendation. Tesla informed you that the operational design domain ODD restrictions would not be applied. I'm baffled. Is there any explanation for Tesla giving you that response?

Mr. SUMWALT. Senator Blumenthal, we are extremely disappointed with that response. We found that the having something on the wheel is not an effective surrogate for determining whether or not the driver is engaged.

Senator BLUMENTHAL. And what are you going to do about it? Have you gone back to Tesla and demanded that they acknowledge that these ODD restrictions should apply?

Mr. SUMWALT. Senator Blumenthal is, I think you are aware of the NTSB does not have the statutory authority to force anybody to do anything. But—

Senator BLUMENTHAL. I am well aware of that fact and I regret it, and I don't blame you for it, but what have you recommended to other agencies and who should be held accountable?

Mr. SUMWALT. Well, that's certainly what Congress can step in and cause change to be made and we're happy that Congress does do that.

Senator BLUMENTHAL. Let me ask you because my time is limited, I'm going to move, but I would like further responses from others to that question about Tesla.

In the United States, one fatality occurs approximately every 100 million miles driven in non-automated vehicles. According to the RAND Corporation, proved with 95 percent confidence that a driverless car is as safe as human drivers, a driverless car would have to drive 275 miles without a fatality. According to this metric in California, to put it in perspective, last year, all the companies testing AVs drove a total of 2.1 million miles. So we are nowhere near close to that metric, this data is far from promising.

Are you concerned that auto manufacturers are trying to put these cars on the road too quickly without the level of testing that should be required?

Mr. SUMWALT. Is that directed to me, Senator Blumenthal?

Senator BLUMENTHAL. Yes.

Mr. SUMWALT. What we have noticed from our investigation that we completed yesterday is that there is not a sufficient oversight at the Federal level to make sure that the manufacturers of these AVs have put in place a cell safety self-assessment. That is what we have determined.

Senator BLUMENTHAL. Not sufficient oversight.

Mr. SUMWALT. That is correct.

Senator BLUMENTHAL. Let me follow up on Senator Tester's question to you Dr. Owens. He asked when a Level 5 car will be on the road. And let me ask you that question again. Can you give us any ballpark number of years?

Dr. OWENS. Thank you, Senator Blumenthal. This is an area again, where the technology is driving the—

Senator BLUMENTHAL. I understand, but if you can't, I heard your answer before. The way I would interpret your answer, we have no idea when Level 5 cars will be safely on the roads. Is that pretty much correct?

Dr. OWENS. I would expect it's not going to be within the next couple of years. So it's probably five, 10 years off or, or longer perhaps. Developers are giving us different answers.

Senator BLUMENTHAL. At least five, which probably is 10 and maybe longer. Is that correct?

Dr. OWENS. It depends on when the technology is proven and that is something that is very much in development.

Senator BLUMENTHAL. When will we see Level 3 cars on the road?

Dr. OWENS. We could see Level 3 cars relatively soon. There are a number of manufacturers who are working on those technologies right now.

Senator BLUMENTHAL. When will we see them on the road safely?

Dr. OWENS. Our hope, our intention is that these cars are on the road safely from the first day that they're on the road.

Senator BLUMENTHAL. And when you say relatively soon, are we talking 5 years, 10 years?

Dr. OWENS. We could potentially be seeing Level 3 vehicles on the roads within the next couple of years.

Senator BLUMENTHAL. Within the next 2 years?

Dr. OWENS. Potentially.

Senator BLUMENTHAL. Let me ask you about cyber, finally. The introduction of Internet connected cars have already created safety and privacy risks for drivers and others. I don't think you've been asked about this issue. And probably the reason is that we don't know what Federal agency will be responsible for protecting against hacking against cyber intrusion.

Which Federal agency is primarily responsible? Who exactly is going to be held accountable for ensuring that cars on the road are not vulnerable to cybersecurity risks?

Dr. OWENS. Senator Blumenthal, if the cybersecurity affects the safe operation of the vehicle, then it's within NHTSA's purview. If it affects privacy, then that would be something that would probably be within the FTC's purview.

I can tell you that we are very active in the cybersecurity area. It's a significant threat, it's an evolving dynamic threat. Our cars today are heavily computerized. We have—we treat software exactly the same as hardware when it comes to defects. And in fact, we've issued a recall relating to a cybersecurity vulnerability several years ago and that resulted in the recall of 1.4 million vehicles.

We're in the process of updating our cybersecurity best practices right now and we encourage the creation of the automotive ISAC. Which is a forum for industry to come together to discuss lessons learned and incident management.

Internally when we learn of an incident or a vulnerability we take action, we validate whether the incident or vulnerability poses a safety risk. And if we determine that it presents an unreasonable

risk to safety, we will not hesitate to take action to ensure that there's a recall in place.

Senator BLUMENTHAL. Thank you. Thank you all for being here.

The CHAIRMAN. Thank you, Senator Blumenthal. We have a vote on but I think we can squeeze the next two questioners in. And so, Senator Sinema is recognized.

**STATEMENT OF HON. KYRSTEN SINEMA,  
U.S. SENATOR FROM ARIZONA**

Senator SINEMA. Thank you, Mr. Chairman we're little so we can squeeze.

Senator ROSEN. Yes, we are——

Senator SINEMA. Yes. Arizona, thanks to its highly skilled workforce and excellent weather is a magnet for autonomous vehicle development and testing. *The New York Times* called Arizona the place where self-driving cars go to learn. And Arizonans are at the forefront of this innovative technology that's creating great STEM jobs and revolutionizing the future of transportation. Many groundbreaking companies have invested in Arizona and these operations are growing as the technology advances.

For example, the autonomous vehicle company, Waymo, has hundreds of vehicles in the Valley, including a partnership with Lyft for ride-sharing and a partnership with Valley Metro for last mile service for seniors. Earlier this year, Nuro, a company developing passenger-less cargo vehicles performed a pilot program with Fry's food stores to deliver groceries in the City of Scottsdale. And Too Simple, an autonomous trucking company with a facility in Tucson has been testing its vehicles on the I-10, between Phoenix and Tucson.

With all of these advancements, it's critical to remember that safety for both passengers and the public is the most important priority for autonomous vehicle manufacturing and testing. Sadly, last year, Arizona was a site of a fatality related to testing self-driving cars. Yesterday the NTSB released its final report regarding the 2018 collision involving a pedestrian in Tempe, Arizona. The NTSB report determined the probable cause of the accident was distraction of the safety driver and included recommendations about testing procedures and oversight.

My first question is for Chairman Sumwalt. In the final report, the NTSB calls for greater oversight of AV testing from both the Federal Government and state governments. Can you describe the NTSB's recommended breakdown of safety responsibility between the state and Federal Government related to AV testing?

Mr. SUMWALT. Yes, Senator Sinema, thank you very much for that question. And we do feel that the states certainly retain the responsibility for—they need to know what self-driving vehicles are being tested on their roadways, the qualifications of the person who will actually be monitoring the self-driving car while it's being tested. We want to make sure that the state has in place a plan to assess the safety of this before it begins.

Senator SINEMA. Thank you. My next question is for Acting Under Secretary Szabat and Acting Administrator Owens. According to the NTSB report, the pedestrian fatality in Tempe could have been avoided had the safety driver been paying attention to

the roadway. But until a manufacturer perfects a completely autonomous vehicle, the driver still plays an important role during testing, even if the car takes on more driving tasks. So driver engagement and the interface between the machine and the driver is crucial for safety, particularly during vehicle testing. The DOT's AV 3.0 guidance addresses human factors and drive engagement.

So based on this accident, what is the DOT doing to keep safety drivers engaged and is the DOT planning to change or update its guidance based on this crash in Arizona?

Dr. OWENS. Thank you, Senator. What happened in Tempe was a terrible tragedy and our condolences go to the family of the victim.

As you note, every vehicle on the roads today requires an operator to be in control and that operator has the responsibility to ensure the safe operation of the vehicle at all times and particularly when a vehicle is in test operation. When there's on-road testing that's going on, the company that is doing the testing has the obligation to ensure that their test drivers are properly qualified, properly trained and properly supervised, and that the test is conducted in a manner that is fully consistent with safety.

We are currently undertaking a special crash investigation into the Tempe incident. So I'm not able to speak more specifically about that incident at this time. But what I will note is that we encourage—we encourage the states, our state partners, as well as industry, to ensure that when they're taking action that they're doing so in a manner that is consistent with safety.

Mr. SZABAT. And Madam Senator, if I may add AV 3.0 will be updated. That update will include the lessons learned from this from this crash. It will include, be informed by the recommendations that we have received from the NTSB as well.

Senator SINEMA. Thank you Mr. Chairman. I yield back.

The CHAIRMAN. Thank you. Senator Rosen.

**STATEMENT OF HON. JACKY ROSEN,  
U.S. SENATOR FROM NEVADA**

Senator ROSEN. Thank you Mr. Chairman. I'm going to go very quickly because we have votes right now. I want to just switch over to talk about disabled populations because self-driving cars have the potential to dramatically improve the lives of people who cannot drive or have limited access to transportation. Their potential to increase mobility for Americans with disabilities bring more people into the workforce and community and save substantially on healthcare is vast.

So just this morning I met with the Nevada Center for Excellence in Disabilities. They're attending a conference here in DC. They're talking about their transit challenges faced not just by Nevadans with disabilities, but all across this Nation. So we need to be careful in how we craft regulations to allow growth in the field of autonomous vehicles while ensuring we're meeting the requirements of the Americans with Disabilities Acts and respect those who have disabilities, including the over 300,000 Nevadans.

So, Mr. Szabat, just quickly, can you talk about how the car manufacturers, technology companies, policymakers, how can we ensure that our constituents with disabilities, sensory, cognitive,



physical, wheelchairs how can we fully—how can they fully benefit using this new technology?

Mr. SZABAT. Senator, thank you for raising this issue. This from our perspective is one of the great potential benefits as we further develop autonomous vehicle technologies, is its ability to increase the freedom and mobility of America's disabled communities.

As I mentioned, my opening statement, I think one of the key lessons that we've learned going into this is that the key stakeholder we have here are the members of the communities themselves. And, you know, their mantra is nothing about us without us. And we in the Department are trying to incorporate that into our own planning. So rather than a top down, we want to work with them as the technology develops to identify where it can have the best access for the communities.

So as part of that you know, we hosted just a few weeks ago the Access of Mobility for All Summit in the Department. But we've announced \$50 million in new initiatives to expand access for people with disabilities. I think a key part of this is we're going to have a complete trip deployment solicitation, \$40 million will be available to enable communities to showcase innovative partnerships, technologies to determine how can we help the communities. And we'll be soliciting input from the communities themselves to help us determine how we can do that.

Senator ROSEN. Now, that's fantastic, especially on our Aging Committee, those of us getting older, having increased needs that will be very effective. I'm going to yield back. Thank you, Mr. Chairman.

The CHAIRMAN. Thank you, Senator Rosen. And Senator Markey has requested to be recognized for two minutes.

Senator MARKEY. Two minutes. Thank you Mr. Chairman.

The CHAIRMAN. And I've denied that request.

[Laughter.]

The CHAIRMAN. Senator Markey is recognized.

Senator MARKEY. These new vehicles are just computers on wheels. They can be cyber hacked, they can be taken over. It can be a very dangerous situation. And that remote control takeover of a car can be very dangerous.

A recent report by Consumer Watchdog automakers have acknowledged the dangers of Internet-connected cars to their investors and shareholders, but they have not disclosed those same cyber risks to the public at-large. And I asked unanimous consent that this report be entered into the record.

The CHAIRMAN. Without objection it will be done.

[Consumer Watchdog report entered.]



# KILL SWITCH



**WHY CONNECTED CARS CAN BE  
KILLING MACHINES AND HOW TO  
TURN THEM OFF**

 **Consumer  
Watchdog**

**EXECUTIVE SUMMARY**

For the past five months Consumer Watchdog worked with a group of car industry technologists and engineers concerned about the danger of Internet connectivity in modern non-self-driving cars and their susceptibility to hacking. The result is this investigative report exposing the perils of “connected cars” without compromising the identity of the industry insiders, who could lose their jobs as a result.

The report that follows, “Kill Switch,” reflects the consensus concerns of these industry technologists about the security design flaws in the new fleet of connected cars. With tens of millions of these Internet-connected cars already operating on American roads, these automobiles will comprise the majority of new cars by the end of the year. This report is presented as a basis for conversation and new security protocols.

**Background**

While self-driving cars have received lots of attention, the auto industry is quietly installing components that carry similar risks into ordinary consumer automobiles. Widespread use of self-driving cars is years or decades away. However, 17 million new cars are deployed on American roads each year in which the mechanisms that control movement—accelerating, steering, and braking—can be overridden by computers and software.

This computerization has been accompanied by a growing trend of connecting cars to wide-area communications networks—making them part of the Internet of Things (IoT). This is a dangerous combination, as it creates the potential for hackers to take control of vehicles remotely. Unlike other “connected” technologies in which hackers can only steal information or money, hacked cars have the potential to cause property damage and deaths. Whereas the military and aviation industries carefully avoid connecting dangerous machines to the Internet, the auto industry has yet to learn this lesson.

Millions of cars on the Internet running the same software means a single exploit can affect millions of vehicles simultaneously. A hacker with only modest resources could launch a massive attack against our automotive infrastructure, potentially causing thousands of fatalities and disrupting our most critical form of transportation. Recent reporting about United States efforts to counter Russian cyber-attacks with its own online infiltration indicate that we increasingly live in the era of cyber warfare. An attack targeting transportation infrastructure is a growing possibility.

Most concerning is that automotive industry executives are aware of these risks, yet are proceeding nonetheless to deploy these technologies, putting corporate profits ahead of consumer safety and national security.

**Main Findings of the Investigation**

The top ten car brands in the U.S., accounting for 95% of car sales, all sell Internet-connected cars. The three top-selling carmakers in the U.S., GM, Toyota, and Ford, representing nearly half the U.S. auto market, will only sell Internet-connected cars by the end of this year.

The troubling issue for industry technologists is that these vehicles' safety-critical systems are being linked to the Internet without adequate security and with no way to disconnect them in the event of a fleet-wide hack.

Most connected vehicles share the same vulnerability. The head unit (sometimes called the infotainment system) is connected to the Internet through a cellular connection and also to the vehicle's CAN (Controller Area Network) buses. This technology dating to the 1980s links the vehicle's most critical systems, such as the engine and the brakes.

Experts agree that connecting safety-critical components to the Internet through a complex information and entertainment device is a security flaw. This design allows hackers to control a vehicle's operations and take it over from across the Internet.

By 2022, no less than two-thirds of new cars on American roads will have online connections to the cars' safety-critical system, putting them at risk of deadly hacks. Car makers have many economic motivations to connect vehicles to the Internet—from saving money on recalls by updating vehicle software over-the-air to collecting valuable data on how fast we drive to where we shop. While car companies market flashy new features, such as remotely starting cars from smartphones, technologists report the companies have not prepared for the grave security implications of a connected car fleet.

Car makers have even acknowledged to investors and shareholders the dangers of connected cars and their vulnerability to hacking. However, technologists report the companies are deceiving the public about the risks and their inability to eliminate them after nearly a decade of trying.

Technical experts explain that using smartphone technology in cars, technology that was never designed to protect safety-critical systems, is a recipe for disaster. A plausible scenario involving a fleet-wide hack during rush hour in major U.S. metropolitan areas could result in approximately 3,000 fatalities, the same death toll as the 9/11- attack.

Expert hackers report that time and money are the only things that stand between them and hacking a fleet of cars. Software design practices that result in frequent hacks of everything from consumer electronics to financial systems cannot be trusted in cars, which can endanger not only the lives of their occupants, but also pedestrians and everyone else on the road.

Connected cars have suffered more than half a dozen high-profile hacks in recent years. All have been benign demonstrations, not intended to cause harm. Hundreds more vulnerabilities have been reported to carmaker “bug bounty” programs. Experts report a hack of American vehicles designed to cause damage is inevitable without better security. The car industry’s response when vulnerabilities are exposed is to patch individual security holes and ignore the design problems that underlie them.

Car hacking demonstrations to date have always focused on a single vehicle, but the networked nature of connected cars creates numerous avenues for a fleet-wide attack. Viruses can spread vehicle-to-vehicle. Malicious WIFI hotspots can infect any susceptible vehicle that passes within range. Cars can be infected with “sleepers” malware that wakes at a given date and time, or in response to an external signal, resulting in a massive coordinated attack.

Security-critical components in cars are black boxes. Even the car makers themselves often do not know the origins of the software they use, nor their true risks.

Vehicles from many major carmakers—including Tesla, Audi, Hyundai, and Mercedes—rely heavily on software written by third parties. This includes open source software, like Android, Linux, and FreeRTOS. This software often comprises contributions from hundreds or thousands of different authors around the world, and there is usually little accountability for flaws. For example, FreeRTOS, used in critical systems by Tesla, had major vulnerabilities discovered in October 2018, but Tesla never acknowledged using the software, the vulnerability, or whether it patched the problem.

The veil of secrecy surrounding automotive software and the ability to update it “over the air” without touching the vehicle lets automakers cover up safety problems and sloppy testing practices. Consumers are driving cars whose systems run on unfinished and under-tested software.

Despite working on the problem for more than a decade, carmakers have proven incapable of creating Internet-connected vehicles that are immune to hacking, which is the only standard that can keep consumers safe. With connected cars rapidly overtaking the market, consumers will soon have no haven from the online connections that threaten them.

To protect the public, carmakers should install 50-cent “kill switches” in every vehicle, allowing consumers to physically disconnect their cars from the Internet and other wide-area networks. Otherwise, if a 9/11-like cyber-attack on our cars were to occur, recovery would be difficult because there is currently no way to disconnect our cars quickly and safely. Mandatory “kill switches” would solve that problem.

**Road Map Recommendations**

The report offers the following road map for the industry and regulators to follow to ensure the safety and security of automobiles for the public.

As hacked cars have the potential to kill thousands of people, the industry must respond both immediately and in the long term to this threat.

The car industry should respond immediately with more transparency and consumer control.

- Regulators should require automakers to publicly disclose the authorship, safety certifications, and testing methodology used for all safety and security critical software, allowing for analysis by independent regulatory and testing agencies.
- CEOs of auto manufacturers should sign personal statements and accept personal legal liability for the cyber-security status of their cars.
- The industry should agree to a general standard protocol that cars not be connected to wide-area networks until they can be proven immune to hackers.

New car designs take three to five years to reach consumers. However, every carmaker should commit before year's end that:

- Each one of their cars at the earliest possible date will come with an Internet kill-switch that physically disconnects the Internet from safety-critical systems.
- Future designs will completely isolate safety-critical systems from infotainment systems connected to the Internet or other networks because connecting safety-critical systems to the Internet is inherently dangerous design.

If carmakers do not commit by December 31, 2019, legislators and regulators should mandate these protections.

**TABLE OF CONTENTS**

<b>Most 2020 Model Cars are Connected to the Internet</b>	<b>6</b>
Figure I: Top Selling U.S. Carmakers' Connected Car Goals	7
Figure II: Vulnerable Connectivity Features in Top Models	9
<b>The Threat: Internet Connectivity to Safety-Critical Systems</b>	<b>9</b>
<b>Anatomy of a Remote Car Hack</b>	<b>10</b>
<b>CEOs Acknowledge Hacking Risks To Investors</b>	<b>12</b>
Figure III: Investor Disclosures Acknowledge Hacking Risks	13
<b>Even The Automakers Don't Know Who Writes Automotive Software</b>	<b>16</b>
Figure IV: Known Current and Future Open Source Operating Systems	17
<b>Breeding Software Bugs That Can Be Exploited</b>	<b>18</b>
Figure V: List of Bug Bounties	20
<b>The Mythological "White Hat" Hacker</b>	<b>20</b>
<b>Over-The-Air Updates: Blessing or Curse?</b>	<b>22</b>
<b>Anatomy and Scenarios of a Fleet-Wide Hack</b>	<b>26</b>
<b>Recent History of Car Hackings</b>	<b>34</b>
<b>Timeline of Notable Car Hacks</b>	<b>36</b>
<b>Profits Over Security and Safety</b>	<b>39</b>
<b>Potential Damage from a Large-Scale Hack</b>	<b>42</b>
<b>The Future of Auto Safety: The Kill Switch &amp; Beyond</b>	<b>44</b>
<b>APPENDIX: Key Answers From Top Engineers</b>	<b>47</b>

### Most 2020 Model Cars Are Connected to the Internet

There are about 50 million “connected cars”—cars that communicate with the cellular network or with each other—on U.S. roads today<sup>1</sup>, representing about 20% of all cars in use, but those numbers are rising rapidly. About 17 million new cars are deployed on American roads each year<sup>2</sup>.

Top-selling automakers including General Motors, Ford, and Toyota have committed to making all of their new models “connected cars” in upcoming model years. This makes connected cars a much more serious and immediate risk to public safety than self-driving cars.<sup>3</sup>



<sup>1</sup> “Stock of Connected Cars,” *Statista*: <https://www.statista.com/outlook/320/109/connected-car/united-states#market-users>

<sup>2</sup> “Car Sales set another U.S. Record,” Ahiza Garcia, *CNN Business*, Jan 2017 <http://money.cnn.com/2017/01/04/news/companies/car-sales-2016/index.html>

<sup>3</sup> “Market share held by selected automobile manufacturers in the United States in 2018,” *Statista*, 2019 <https://www.statista.com/statistics/249375/us-market-share-of-selected-automobile-manufacturers/>



Figure 1: Top Selling U.S. Carmakers' Connected Car Goals <sup>4 5 6 7 8 9</sup>

Top-selling Makes in U.S.	U.S. Market Share	New cars at risk due to connectivity
General Motors (Chevy, Buick, Cadillac, etc.)	17.02%	All new vehicles today
Toyota	14.63%	All by 2020
Ford	14.44%	All by 2020
Fiat-Chrysler	12.98%	Next generation platform providing connectivity in all cars by 2022
Renault-Nissan-Mitsubishi	9.35%	90% of new cars by 2022
Honda	9.10%	Unknown
Hyundai/Kia	7.42%	Unknown
Subaru	3.94%	Unknown
Volkswagen	3.69%	Unknown
Daimler	2.06%	Unknown

In model year 2019, connected cars are already commonplace. The top ten car brands in the U.S., accounting for 95% of car sales, all sell Internet-connected cars. All of the top

<sup>4</sup> "Market share held by selected automobile manufacturers in the United States in 2018," *Statista*, 2019 <https://www.statista.com/statistics/249375/us-market-share-of-selected-automobile-manufacturers/>

<sup>5</sup> "GM's OnStar service explained," Jeremy Laukkonen, *Lifewire*, Jan 2019: <https://www.lifewire.com/gms-onstar-service-534811>

<sup>6</sup> "KDDI and AT&T to Connect Toyota and Lexus Vehicles," Toyota, Jan. 2019: <https://corporatenews.pressroom.toyota.com/releases/kddi+att+connect+toyota+lexus+vehicles.htm>

<sup>7</sup> "Why Ford's Cellular to Vehicle Matters," Nicholas Rossolillo, *The Motley Fool*, Jan 2019: <https://finance.yahoo.com/news/why-ford-apos-cellular-vehicle-151600854.html>

<sup>8</sup> "FCA Selects HARMAN (Samsung) and Google Technologies for New Global Connected Vehicle Ecosystem," Fiat Chrysler Automobiles, Apr 2019 [https://www.fcagroup.com/en-US/media\\_center/fca\\_press\\_release/2019/april/Pages/fca-selects-harman-and-google-technologies-for-new-global-connected-vehicle-ecosystem.aspx](https://www.fcagroup.com/en-US/media_center/fca_press_release/2019/april/Pages/fca-selects-harman-and-google-technologies-for-new-global-connected-vehicle-ecosystem.aspx)

<sup>9</sup> "Nissan, Renault ready next-gen connected car platform," Hans Greimel, *Automotive News*, Mar. 2019 <https://www.autonews.com/technology/nissan-renault-ready-next-gen-connected-car-platform>

ten best-selling sedans in the U.S. are available with Internet connectivity. As of model year 2019, four of the ten best-selling sedans are only available with Internet capabilities. The connectivity is marketed under various names, but a common feature is the ability to control your car from an unlimited distance away using a smartphone app. If you can control your car from any distance, so can a hacker. Other “connected car” features may include voice assistant integration (e.g., Amazon “Alexa”), and the ability for the automaker to update the car’s software “over the air”.

*“If you can control your car from any  
distance, so can a hacker.”*

Many automakers are touting the ability to start your car’s climate control system from your smartphone, so the cabin is a comfortable temperature before you get in. This capability requires the car to have cellular or other wide-area connectivity, and internal communication linking that connectivity to the most critical parts of the vehicle. In many cases, these capabilities are optional, and require you to pay a recurring service charge. However, whether you subscribe to the service or not, as long as the equipment is present in your car, the car could be vulnerable to hackers.

The chart below shows the availability of dangerous connectivity features in a sampling of popular model year 2019 cars<sup>10</sup>. Model year 2020 cars will be rolled out to consumers this fall. The list of affected vehicles will expand as automakers follow through on their promises to make these technologies standard across all vehicles. Every major automaker now offers connectivity. Some brands, like BMW, Mercedes, and Tesla, have already made connectivity standard in 100% of their vehicles, and other makes are rapidly approaching that goal.

---

<sup>10</sup> “America’s 9 Best-Selling Cars of 2018 by Category,” *CARFAX*: <https://www.carfax.com/blog/2018-best-selling-cars-by-category>

Figure II: Vulnerable Connectivity Features in Top Models

Vehicle	Commercial Name(s)	Models
Toyota Camry	Remote Connect, Safety Connect	*** All Models ***
Lexus ES	Enform	*** All Models ***
Honda Civic	HondaLink	All hatchbacks; coupes and sedans "Sport" model and above
Mercedes C-Class	me connect	*** All Models***
Subaru Outback	STARLINK	*** All Models ***
Tesla Model 3	<i>N/A -- connectivity is an integral feature in all Tesla vehicles</i>	*** All Models ***
Ford F-150	SYNC Connect	All but the lowest-end models
BMW 5-series	ConnectedDrive	*** All Models***

#### The Threat: Internet Connectivity to Safety-Critical Systems

Most connected vehicles share the same vulnerability. The head unit (sometimes called the infotainment system) is generally responsible for non-critical information and entertainment, such as music and in-car navigation. It is connected to the Internet through a cellular connection, and also to the vehicle's CAN (Controller Area Network) buses. CAN buses are a technology dating to the 1980s that links the vehicle's most critical systems, such as the engine and the brakes.

Like any complex electronic device on the Internet, a head unit is vulnerable to hackers. To date, nearly every documented car hack has used the head unit, which is complex and not designed for security, as a bridge from the Internet to the brakes and other safety-critical components.

Experts agree that connecting safety-critical components to the Internet through a complex information and entertainment device is a security flaw. This design allows hackers to control a vehicle's operations and take it over from across the Internet. This

security flaw is evident in the wiring diagram below, obtained from Toyota's own Technical Information System (TIS)<sup>11</sup>:

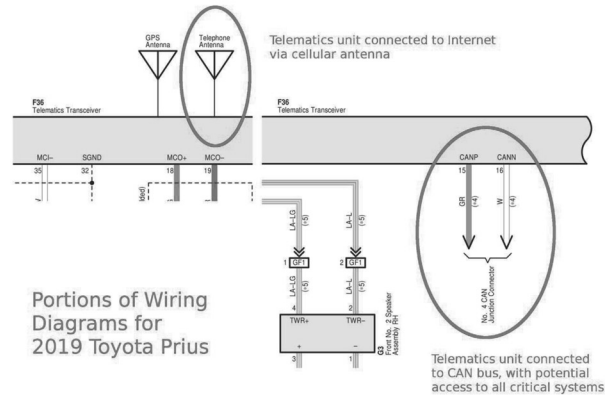

Some more sophisticated vehicles add a “gateway unit” between the head unit and the CAN bus. The gateway unit is responsible for ensuring only authorized communication can reach the safety-critical systems. While this would seem to solve the problem, it really only adds more complexity. A successful attack must pass through the gateway unit, requiring a more sophisticated attack. However, the additional hardware and software in the gateway unit also create more opportunity for hackers to find vulnerabilities.

#### Anatomy of a Remote Car Hack

A dangerous remote hack requires two components: a means of accessing the vehicle's internal systems from afar, and a means of taking control once inside. Neither component on its own is particularly dangerous.

<sup>11</sup> Technical Information System, Toyota: <https://techinfo.toyota.com/techInfoPortal/appmanager/t3/ti>

For more than 30 years, the most common electronic communication medium between components in cars has been the CAN bus<sup>12</sup>. Given that networking technology was in its infancy when CAN was developed, security was simply not a consideration in its design. A hacker can easily inject malicious messages onto a CAN bus to make a car potentially unsafe.<sup>13</sup> However, without a scalable way for hackers to access the CAN bus, this wasn't problematic when CAN was designed—attacks were only possible with physical access to the vehicle. That changed when cars were connected to the cellular network, providing potential outside access to the insecure, yet safety-critical systems<sup>14</sup>. Not only does this allow a hacker to attack a car without physical access to it, it allows a single hacker to attack many cars at once.

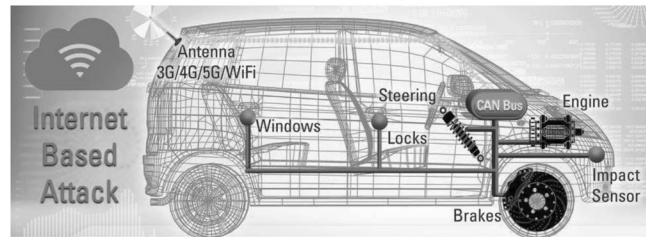

This is not simply a theoretical possibility. White-hat hackers have demonstrated these capabilities more than a dozen times in the past decade (see “Recent History of Car Hacking” below). For example, in 2015, when researchers Chris Valasek and Charlie Miller shut down a Jeep Cherokee’s engine while it was on the highway<sup>15</sup>, and later disabled its brakes, they did this from miles away, over the Internet, without physically touching the vehicle. This exploited a vulnerability in the radio to access safety-critical systems through the CAN bus. The vulnerability allowed them to issue commands to the Jeep’s engines, brakes, and other systems from a laptop located miles away.

<sup>12</sup> “History of the CAN Technology,” CiA <https://www.can-cia.org/can-knowledge/can/can-history/>

<sup>13</sup> “Automotive Security in a CAN,” Bill Boldt, *Electronic Design*, Sep. 2017: <http://www.electronicdesign.com/automotive/automotive-security-can>

<sup>14</sup> “Why the Connected Car is One of this Generation’s Biggest Security Risks,” Conner Forrest, *ZDnet*, Mar. 2016 <https://www.zdnet.com/article/why-the-connected-car-is-one-of-this-generation-s-biggest-security-risks/>

<sup>15</sup> “Hackers Remotely Kill Jeep on the Highway,” Andy Greenberg, *Wired*, July 2015: <https://www.wired.com/2015/07/hackers-remotely-kill-jeep-highway/>

A hackers' ability to control your car is not limited to the features officially supported by the car's smartphone app. Once the hacker has gained access to your car's electronics, all of the car's systems become vulnerable. In the hands of a hacker, a system designed to let you activate your car's air conditioning from your smartphone could be used to disable your car's brakes and airbags from anywhere in the world.

Consumers currently have no control over this aspect of their own vehicles: they do not have the option of disconnecting their car from the Internet. The software sitting between the Internet and the safety-critical systems, and therefore most critical to fending off cyber-attack, is a veritable black box. The automaker provides no information and no guarantees whatsoever about its reliability or testing, or even its authorship.

Even as automakers aggressively market the hot new connected car features to the public, the hacking risks are real enough that carmakers have warned the one group of people they are legally obligated to level with: investors.

*“Despite extensive security measures,  
the risks in this area are classified as high.”*

— BMW Internal Report

#### **CEOs Acknowledge Hacking Risks To Investors**

A review of several of the automakers' annual reports and Securities Exchange Commission (SEC) statements finds that car companies including Daimler Chrysler, Honda, Toyota, Tesla, Ford, and BMW acknowledge to their shareholders that security and hacking concerns are real and growing.

Figure III: Investor Disclosures Acknowledge Hacking Risks<sup>16 17 18 19 20</sup>

Tesla	2019 SEC 10-K	"We have designed, implemented and tested security measures intended to prevent unauthorized access to our information technology networks, our products and their systems... <b>there can be no assurance that vulnerabilities will not be exploited in the future before they can be identified, or that our remediation efforts are or will be successful.</b> "
Daimler Chrysler	2018 Annual Report	"Due in particular to the changed risk situation relating to cybercrime and hacker attacks, the possible impact of information-technology <b>risks has increased compared with the previous year from Medium to High.</b> "

(continued)

<sup>16</sup> Tesla, 2018 Securities and Exchange Commission Form 10-K, Page 29: <https://ir.tesla.com/node/19496/html>

<sup>17</sup> Daimler Chrysler 2018 Annual Report, Page 151: <https://www.daimler.com/documents/investors/reports/annual-report/daimler/daimler-ir-annual-report-2018.pdf>

<sup>18</sup> Ford Motor Company, Form 10-K Securities and Exchange Commission 2018, Page 18: [https://s22.q4cdn.com/857684434/files/doc\\_financials/2019/annual/ford-10k.pdf](https://s22.q4cdn.com/857684434/files/doc_financials/2019/annual/ford-10k.pdf)

<sup>19</sup> General Motors, Form 10-K Securities and Exchange Commission 2018, Page 14: <https://www.sec.gov/Archives/edgar/data/1467858/000146785819000033/gm201810k.htm>

<sup>20</sup> BMW, Annual Report 2018, Page 98: [https://www.bmwgroup.com/content/dam/bmw-group-websites/bmwgroup.com/ir/downloads/en/2019/gb/BMW-GB18\\_en\\_Finanzbericht\\_190315\\_ONLINE.pdf](https://www.bmwgroup.com/content/dam/bmw-group-websites/bmwgroup.com/ir/downloads/en/2019/gb/BMW-GB18_en_Finanzbericht_190315_ONLINE.pdf)

Investor Disclosures Acknowledge Hacking Risks		
Ford	2018 SEC 10-K	<p>“Such cyber incidents could materially disrupt operational systems; result in loss of trade secrets or other proprietary or competitively sensitive information; compromise the privacy of personal information of customers, employees, or others; jeopardize the security of our facilities; <b>affect the performance of in-vehicle systems; and/or impact the safety of our vehicles. A cyber incident could be caused by malicious third parties using sophisticated, targeted methods to circumvent firewalls, encryption, and other security defenses, including hacking, fraud, trickery, or other forms of deception. We, our suppliers, and our dealers have been the target of these types of attacks in the past and such attacks are likely to occur in the future. The techniques used for attacks by third parties change frequently and may become more sophisticated, which may cause cyber incidents to be difficult to detect for long periods of time.</b> Our networks and in-vehicle systems may also be affected by computer viruses or breaches due to the negligence or misconduct of employees, contractors, and/or others who have access to our networks and systems.”</p>



Investor Disclosures Acknowledge Hacking Risks		
General Motors	2018 Annual Report	<p><b>“Security breaches and other disruptions of our in-vehicle systems could impact the safety of our customers and reduce confidence in GM and our products.</b> Our vehicles contain complex information technology systems. These systems control various vehicle functions including engine, transmission, safety, steering, navigation, acceleration, braking, window and door lock functions. We have designed, implemented and tested security measures intended to prevent unauthorized access to these systems. However, hackers have reportedly attempted, and may attempt in the future, to gain unauthorized access to modify, alter and use such systems to gain control of, or to change, our vehicles’ functionality, user interface and performance characteristics, or to gain access to data stored in or generated by the vehicle.”</p>
BMW	2018 Annual Report	<p>“If risks relating to information security, data protection and IT were to materialize, they could have a high earnings impact over the two-year assessment period. <b>Despite extensive security measures, the risks in this area are classified as high.</b>”</p>

Carmakers have acknowledged to their investors the risk that their cars will be hacked is high now that safety-critical systems are being connected to the Internet. The question that baffles technologists is why automakers continue to invest in unsafe, poorly-architected technologies even though the risks have been known to automakers for almost a decade.

The military industrial complex and aviation industries have addressed the threat of cyberattack by not connecting critical systems to the Internet. In cases where Internet connectivity is required, they invest in proprietary software that is simple and effective, focused on security rather than features, often using mathematical proofs to show that these systems are immune to attack. By contrast, automakers are utilizing smartphone technology and open source operating systems that run them—systems that have been proven time and again to be vulnerable—as the basis for motor vehicle safety, on which hundreds of millions of Americans’ lives depend.

#### Even The Automakers Don’t Know Who Writes Automotive Software

While practices vary by automaker, the bulk of software running in modern cars is not written by the automakers. Much of it comes from suppliers, such as Samsung-owned Harman, best known for its stereos. Harman developed the flawed infotainment system that allowed Valasek and Miller to gain remote access to the Jeep Cherokee in 2015. But frequently, even first-tier suppliers like Harman are not the original authors.

To minimize costs, the auto industry makes extensive use of free “open source” software, such as Linux and Android. Open source software is “crowdsourced”, in the sense that hundreds or thousands of unpaid hobbyists from around the world may have contributed to its design and implementation. While open source software use is common in the software industry, and can avoid some up-front expenses, it comes with serious safety and reliability pitfalls, most notably that there is rarely any accountability for the quality or support of the software. Most open-source software includes a boilerplate legal disclaimer, that begins (capitalized as shown): “THE SOFTWARE IS PROVIDED “AS IS”, WITHOUT WARRANTY OF ANY KIND, EXPRESS OR IMPLIED...” Android and Linux have a long and ever-changing list of security vulnerabilities.<sup>21</sup>

Two anonymous ex-Tesla employees independently reported that the “gateway unit” in Tesla cars, responsible for protecting the most sensitive systems in the car from Internet traffic, runs an open-source operating system called FreeRTOS, common in “Internet of Things” (IoT) devices. In October

*“More training  
and  
certification is  
legally  
mandated to  
style someone’s  
hair or give  
someone a  
massage than to  
write safety-  
critical software  
for cars.”*

<sup>21</sup> *CVE Details*, [https://www.cvedetails.com/vulnerability-list/vendor\\_id-1224/product\\_id-19997/Google-Android.html](https://www.cvedetails.com/vulnerability-list/vendor_id-1224/product_id-19997/Google-Android.html)

2018, security researchers discovered more than a dozen vulnerabilities in FreeRTOS<sup>22</sup>, potentially making all aspects of Internet-connected Tesla vehicles susceptible to hackers. Tesla made no public statement about this safety-related defect in their cars, nor is there record of the problem being reported to regulatory bodies that track automotive safety, such as the National Highway Traffic Safety Administration (NHTSA). There is no public information about how long the vulnerability was present, and how (or even if) it was ultimately fixed.

The world's most widely used open source operating system is Linux. The Linux kernel is also the basis of the Android mobile device operating system. Linux's creator, Linus Torvalds, has said that Linux should not be responsible for protecting human lives. In a November 2015 *Washington Post* interview, Torvalds said the following regarding a hypothetical scenario in which hackers exploit a flaw in Linux to cause a meltdown at a nuclear power plant: "There is no way in hell the problem there is the [Linux] kernel. If you run a nuclear power plant that can kill millions of people, you don't connect it to the Internet." Yet, Linux and Android have found widespread use in Internet-connected cars.

While some automakers are up-front about their use of open-source software in specific systems within their vehicles, the origins and authorship of most automotive software remain beyond public view. Consumers are expected to trust that automakers will use software that is safe, well-maintained, and secure, when all evidence points to the opposite being true.

Figure IV: Known Current and Future Open Source Operating Systems

Linux	Tesla, Audi, Mercedes-Benz, Hyundai, Toyota, BMW, Chevrolet, Honda
Android	Fiat-Chrysler, Volvo, Renault, Nissan, Mitsubishi
FreeRTOS	Tesla

The complex supply chain and large number of unknown authors make it very difficult for automakers to maintain the software that runs our cars, let alone to design the security of the software in a coherent and effective way. Whereas training, licensing, and design quality standards apply in practically every engineering discipline that deals with human safety, the same is not true for automotive software. More training and certification is legally mandated to style someone's hair or give someone a massage than to write safety-critical software for cars. Writing software that could affect the safety of millions of motor

<sup>22</sup> CVE Details, CVE-2018-16528, Dec 2018 <https://www.cvedetails.com/cve/CVE-2018-16528/>

vehicles requires little more than getting hired by a third-tier supplier or participating, possibly anonymously, in one of any number of open source software projects.

### Breeding Software Bugs That Can Be Exploited

A bug is an instance of software failing to behave as it was designed, usually caused by mistakes made during the process of writing the software. Bugs can cause software-based systems to be unreliable, make mistakes, or provide access and control to unauthorized parties.

The larger and more complex the body of code, the more bugs it is likely to contain.<sup>23</sup> This is particularly worrisome given the staggering quantity of software in a typical modern car:

*“Today’s cars can contain over 100 million lines of code. For perspective, an F-35 joint strike fighter jet contains about 9 million,” said Neil Steinkamp, a managing director in Stout’s automotive practice who has led the firm’s research and analysis of automotive recalls. “When you have that much software in a car—and particularly when much of that software is relatively new—there are going to be some issues.”<sup>24</sup>*

Why the disparity between the amount of code in a car versus a plane? There are several likely reasons. Each line of code is a technical liability—a potential failure point. For this reason, aircraft manufacturers try to minimize the amount of code in planes, making the software easier to maintain and less buggy.<sup>25</sup> The auto industry clearly hasn’t adopted this habit yet.

Software used in aircraft must meet stringent government safety standards that don’t apply to the auto industry. On the contrary, the auto industry has repeatedly fought regulation, such as with 2018’s AV START Act, which attempted to block state and local agencies from regulating autonomous vehicle safety so nascent technologies could be rushed to market. In addition to uncovering bugs before the software goes into

<sup>23</sup> “The Danger Of Complexity: More Code, More Bugs.” Chad Perrin, *Tech Republic*, February 2010 <https://www.techrepublic.com/blog/it-security/the-danger-of-complexity-more-code-more-bugs/>

<sup>24</sup> Report reveals spike in software-related recalls; explores emerging risks such as hacking, data breaches, *Stout*, Apr 2016: <https://www.stoutadvisory.com/news/sr-2016-automotive-warranty-recall-report-reveals-spike-software-related-recalls-explores-emer>

<sup>25</sup> “Ford’s new GT has more lines of code than a Boeing jet airliner,” Stephan Edelstein, *Digital Trends*, May 2015: <https://www.digitaltrends.com/cars/the-ford-gt-uses-more-lines-of-code-than-a-boeing-787/> and “How important is it to reduce the number of lines in code” *Ars Technica*, Apr 2013 <https://arstechnica.com/information-technology/2013/04/how-important-is-it-to-reduce-the-number-of-lines-in-code/>

production, the certification process for aircraft software substantially increases the cost per line of code, providing additional incentive to keep the software simple.<sup>26</sup>

One sign that software bugs are a serious and growing concern for all consumer vehicles is the increasing number of software-related recalls. The percentage of auto recalls due to software failures tripled between 2011 and 2016.<sup>27</sup> The 2017 Stout Automotive Warranty and Recall Report shows an increasing trend of software-related recalls both as measured in unique recall campaigns and in the number of vehicles affected.<sup>28</sup> The report offers the following explanation for the increase:

*“One reason for the likelihood of sustained elevated recalls in the coming years is an increased number of defects related to software and integrated electronic components. The continued development of new technologies to assist drivers, differentiate vehicles, and improve vehicle safety also poses recall risk. The widespread use of such innovations as adaptive cruise control, rear backup cameras, forward-collision detection, emergency braking, and brake assist improve vehicle safety, yet add complexity to safety-critical systems.”<sup>29</sup>*

Automakers have a financial incentive to focus on these software-heavy features. Since software does not involve physical parts, once it is developed, it can be mass-produced at practically zero cost. These same software-based features can increase a vehicle’s price to consumers by hundreds or thousands of dollars.

The more software a car contains, the greater the chance of software bugs that hackers can exploit to take control of vehicles. Automaker “bug bounty” programs have demonstrated that vulnerabilities can be purchased for a few tens of thousands of dollars. To someone interested in causing harm, this is much cheaper than conventional weapons. A clever hacker could even make it look like a third party was responsible.

Below is a list of the public auto industry “bug bounty” programs, which have already collectively uncovered hundreds of bugs in carmakers software. Most automakers have no public bug bounty programs at all. Some automakers claim to have bug bounty programs,

<sup>26</sup> “Toyota’s Expensive Software,” Jack Gansle, *Embedded*, Mar 2014: <https://www.embedded.com/electronics-blogs/break-points/4429601/Toyota-s-Expensive-Software>

<sup>27</sup> “Report: Software Issues Have Tripled Auto Recalls in Past Five Years,” Andy Szal, *Manufacturing.net*, Jun 2016: <https://www.manufacturing.net/news/2016/06/report-software-issues-have-tripled-auto-recalls-past-five-years>

<sup>28</sup> 2017 Automotive Warranty and Recall Report, Stout, Figs. 17,18: <https://www.stoutadvisory.com/insights/report/2017-automotive-warranty-recall-report>

<sup>29</sup> 2017 Automotive Warranty and Recall Report, Stout, p. 12: <https://www.stoutadvisory.com/insights/report/2017-automotive-warranty-recall-report>

but the programs are highly limited or ineffectual. For example, GM's bug bounty program is only available to a tiny group of researchers<sup>30</sup>. The hundreds of bugs known to be found through these bug bounty programs are clearly just a fraction of the number of software bugs that exist in cars on American roads and that can be exploited through Internet connections to safety critical systems by hackers.

Figure V: List of Bug Bounties

<b>Fiat-Chrysler</b>	<ul style="list-style-type: none"> <li>• 93 vulnerabilities rewarded</li> <li>• 300+ "hall-of-famers" who reported vulnerabilities</li> <li>• \$4,760 payout per bug on average over the last 3 months</li> <li>• Disclosing details of the vulnerability to the public explicitly prohibited</li> </ul>	<a href="https://bugcrowd.com/fea">https://bugcrowd.com/fea</a>
<b>Tesla</b>	<ul style="list-style-type: none"> <li>• 348 vulnerabilities rewarded</li> <li>• 426 "hall-of-famers"</li> <li>• \$2k average payout</li> </ul>	<a href="https://www.tesla.com/about/security">https://www.tesla.com/about/security</a> <a href="https://bugcrowd.com/tesla">https://bugcrowd.com/tesla</a> <a href="https://techcrunch.com/2018/09/06/teslas-new-bug-bounty-protects-hackers-and-your-warranty/">https://techcrunch.com/2018/09/06/teslas-new-bug-bounty-protects-hackers-and-your-warranty/</a>
<b>BMW</b>	<p>Note: does not appear to offer any reward</p> <p>Note: no statistics available</p>	<a href="https://www.bmwgroup.com/en/general/Security.html">https://www.bmwgroup.com/en/general/Security.html</a>

### The Mythological "White Hat" Hacker

Bug bounty programs are intended to attract the efforts of "white hat" hackers. Unlike "black hat" hackers who are out for personal gain at others' expense, "white hat" hackers

<sup>30</sup> "GM offers bounty software bugs," Nora Naughton, *Detroit News*, Aug. 2018: <https://www.detroitnews.com/story/business/autos/general-motors/2018/08/03/gm-offers-bounty-software-bugs/897057002/>

develop sophisticated techniques for finding vulnerabilities with the goal of helping software developers make their products more resilient. While white hat hackers generally have good intentions, their efforts are often counterproductive to improving security in safety-critical systems.

The biggest flaw in the “white hat” model is that it encourages automakers to repeatedly patch a system that was never fundamentally secure. History has shown that, while this can make incremental improvements, the process never ends, so it does not result in a secure product. Internet-connected cars were unsafe a decade ago and are still unsafe today. With our safety at stake, we cannot wait another decade hoping that this process will eventually find the last remaining security vulnerability.

Despite the ineffectiveness of white hat hackers’ efforts at producing a secure car, their work is extremely valuable to automakers. The continuous churn of finding and fixing bugs presents the illusion that automakers are “working hard” to create a safe product. Paying bug bounties to white hat hackers is generally much less expensive than hiring employees to do the same work, in that automakers need only pay for positive results. Further, the “hacker mystique” contributes to the positive publicity created when a white hat reveals a new vulnerability. Perhaps the most brazen example occurred in May 2018 when, after Keen Security Lab demonstrated more than a dozen vulnerabilities in Internet-connected BMW vehicles, BMW responded by giving them an award<sup>31</sup>, cleverly deflecting the public shame of selling consumers an unsafe product. This may be why automakers are so enamored of white hat hackers, and why the *Detroit Free Press* called hackers “the hottest job in the [auto] industry.”<sup>32</sup>

At the same time, the auto industry manipulates white hat hackers with threats of prosecution under anti-hacking laws, such as the Digital Millennium Copyright Act (DMCA). Most bug bounty programs require white hat hackers to abide by “responsible disclosure” rules, which include keeping details of the vulnerability secret.<sup>33</sup> This is ostensibly to prevent anyone from trying to exploit the vulnerability before it can be fixed. However, it also allows the automaker to control the public message, covering up an

<sup>31</sup> “First-ever BMW Group Digitalization and IT Research Award goes to Tencent Keen Security Lab for their connectivity and cybersecurity research. The two companies plan to expand their cooperation and joint research work.” BMW Group, May 2018: <https://www.press.bmwgroup.com/global/article/detail/T0281245EN/first-ever-bmw-group-digitalization-and-it-research-award-goes-to-tencent-keen-security-lab-for-their-connectivity-and-cybersecurity-research-the-two-companies-plan-to-expand-their-cooperation-and-joint-research-work?language=en>

<sup>32</sup> “Carmakers struggle to hire hackers, the hottest job in the industry,” Jamie LaReau, *Detroit Free Press*, Aug. 20, 2018 <https://www.freep.com/story/money/cars/general-motors/2018/08/20/hottest-auto-job-town-hacking/986636002/>

<sup>33</sup> Product Security, Tesla: <https://www.tesla.com/about/security>

inadequate solution, and ensuring a positive spin on what should be a public embarrassment.

Because vulnerabilities in automobile software are a public safety hazard, we must treat them like other public safety hazards. Consumers don't quietly tell polluters to clean up their acts in return for cash rewards. We inform the EPA. We report reckless drivers to the police. We do not let them hide behind "anti-reckless-driver-reporting laws." Why do we treat automakers whose products threaten public safety any differently? So-called "responsible disclosure" is irresponsible when public safety is at stake.

#### Over-The-Air Updates: Blessing or Curse?

A likely motivation for the proliferation of connected cars is the desire to address the increasing number of software defects with over-the-air (OTA) updates, which are much less expensive and less embarrassing than recalls. Several of the major automakers, including General Motors, have announced their intention to add or expand support of over-the-air (OTA) updates of vehicle software in upcoming model years.<sup>34</sup> While this mode of software release may be acceptable in cell phones and home PCs, it is potentially very dangerous in systems with safety-critical components, such as cars.

"We're talking billions of dollars a year that could be saved," said Sam Abuelsamid, an automotive analyst at the consulting and research firm Navigant. He says software updates are "an increasingly large part of the warranty work that the dealers have to do because there's so much more that's software-driven."<sup>35</sup>

A 2015 IHS report estimated the savings to the auto industry from OTA updates will reach \$35 billion by 2022.<sup>36</sup> While OTA

*"Because vulnerabilities in automobile software are a public safety hazard, we must treat them like other public safety hazards."*

<sup>34</sup> "GM says most new vehicles to get over-the-air upgrade tech by 2023," Joe White, Reuters, May 2019 <https://www.reuters.com/article/us-gm-technology/gm-says-most-new-vehicles-to-get-over-the-air-upgrade-tech-by-2023-idUSKCN1SQ1R7>

<sup>35</sup> "Automakers Embrace Over-the-Air Updates, but Can We Trust Digital Car Repair?" Keith Barry, *Consumer Reports*, Apr. 2018: <https://www.consumerreports.org/automotive-technology/automakers-embrace-over-the-air-updates-can-we-trust-digital-car-repair/>

<sup>36</sup> "Over-the-air Software Updates to Create Boon for Automotive Market," IHS, Sept. 2015: <https://news.ihsmarket.com/press-release/automotive/over-air-software-updates-create-boon-automotive-market-ihs-says>



*“The ability to perform OTA software updates has serious security implications. Performing an OTA update requires the vehicle’s software systems to be remotely accessible.”*

updates might seem like a reasonable way to combat software failures, they carry hidden dangers. Keith Berry, an automotive writer and editor explained by saying, “Modern vehicles run on millions of lines of code that control everything from brakes to steering. When automakers start updating that software remotely, any failure could be just as dangerous as if a mechanic made a faulty repair—and it might affect thousands of vehicles at the same time.”<sup>37</sup>

The ability to perform OTA software updates has serious security implications. Performing an OTA update requires the vehicle’s software systems to be remotely accessible. Put another way, if the vehicle’s systems were not remotely accessible, there would be no way for the OTA update to reach the vehicle.

In their paper “A Survey of Remote Automotive Attack Surfaces,” Valasek and Miller surveyed several popular vehicle makes and models, looking for the combination of vulnerabilities that could enable a dangerous remote hack. In the paper, they rated each vehicle by “Attack Surface” (ease of gaining remote access), “Cyber Physical” (ability to control the vehicle electronically once access is gained), and “Network Architecture” (ease of gaining access to the Cyber Physical components once the Attack Surface is breached.)

The paper includes a table of the vulnerabilities in several makes/models/years, rating each on a scale of pluses and minuses, from “-” (least hackable) to “+++” (most hackable) in Attack Surface, Network Architecture, and Cyber Physical. Note that the trend shows vehicles becoming more vulnerable over time. For example, the 2006 Toyota Prius rates as (-, --, --), whereas the 2010 and 2014 redesigns of the Toyota Prius are rated (+, +, ++). The Ford Fusion saw a similar degradation in security from 2006 to 2014.<sup>38</sup>

The latest model year represented in the chart is 2015, so the information presented predates the publicity of the 2015 Jeep hack. We would expect that automotive security

<sup>37</sup> “Automakers Embrace Over-the-Air Updates, but Can We Trust Digital Car Repair?” Keith Barry, *Consumer Reports*, Apr. 2018: <https://www.consumerreports.org/automotive-technology/automakers-embrace-over-the-air-updates-can-we-trust-digital-car-repair/>

<sup>38</sup> “A Survey of Remote Automotive Attack Surfaces,” Valasek and Miller, <http://illmatics.com/remote%20attack%20surfaces.pdf>

would have improved since then, but that appears not to be the case. While security may have progressed in some areas, it has clearly regressed in others.

In the terms of Valasek and Miller’s “Car Ratings” table, allowing access to vehicles remotely through OTA updates translates to a most hackable “Attack Surface” rating. Further, if the OTA updates apply to safety-critical systems, such as those that control the steering and braking, then the safety-critical systems must be electronically connected to the systems receiving the OTA updates. This translates to a worse “Network Architecture” rating. So, the ability to perform OTA updates means that vehicle security is reduced as measured by two of the three metrics Valasek and Miller used to evaluate vulnerability.

Over-the-air updates are already causing trouble. In February 2018, a Chrysler OTA update caused some cars’ infotainment systems to become unusable.<sup>39</sup> At any reputable repair shop, a technician would verify that the repair was effective and had been performed correctly, but that is not possible when cars are modified en masse with an OTA update. Thankfully, this particular problem did not cause a safety-critical component of the vehicle to malfunction, though such a failure is certainly possible. It did, however, render a safety feature, the rear-view camera, unusable—along with the heat, radio, and navigation.<sup>40</sup> In September 2018, Tesla owners reported a similar OTA update causing the Autopilot feature to stop working.<sup>41</sup>

OTA updates may also have a negative effect on the quality of critical software by reducing the incentive for automakers to test the software fully before release. In May 2018, *Consumer Reports* announced they would not recommend the Tesla Model 3 due in

*“OTA updates  
are a huge  
money-saver, but  
to hackers, they  
are a wide-open  
door into the  
most sensitive  
software of a  
vehicle.”*

<sup>39</sup> “Chrysler’s over-the-air update fiasco is limited to the Northeast, but customers are still waiting for a fix,” Sean O’Kane, *The Verge*, Feb 2018: <https://www.theverge.com/2018/2/14/17013016/flat-chrysler-ota-update-problem-jeep>

<sup>40</sup> “Chrysler’s over-the-air update fiasco is limited to the Northeast, but customers are still waiting for a fix,” Sean O’Kane, *The Verge*, Feb 2018: <https://www.theverge.com/2018/2/14/17013016/flat-chrysler-ota-update-problem-jeep>

<sup>41</sup> “Tesla’s Autopilot Not Working After Latest Over The Air Update,” Ryan Felton, *Jalopnik*, Sept 2018: <https://jalopnik.com/tesla-autopilot-not-working-after-latest-over-the-air-u-1829018937>

part to inconsistent braking behavior.<sup>42</sup> About a week later, Tesla updated all Model 3 cars over-the-air. When *Consumer Reports* re-tested the same car, the average braking distance was reduced by nearly 20 feet, and they reversed their earlier decision, recommending the car.<sup>43</sup> “The fact that Tesla engineers were able to slash nearly 20 feet of stopping distance in a couple of days is a sign that there was something fundamentally broken in what they were doing,” said Abuelsamid.<sup>44</sup> Further, if the software fix was developed in the days between *Consumer Reports*’ two tests, it could not have undergone very much road testing before its release to consumers.

The ability to perform OTA updates creates a perverse incentive: by dramatically reducing the price of patching buggy software, it incentivizes rushing unfinished and poorly-tested products to market. Beating the competition to market with the latest features, even if they do not yet work fully, provides a significant competitive advantage. This poses a serious risk to consumers if the software affects braking, steering, or other critical components of the vehicle. This is exactly what is alleged in a suit brought against Tesla, a pioneer of automotive OTA updates, by a group of its customers. In the suit, the customers claim they paid extra for the privilege of becoming “beta testers of half-baked software that renders Tesla vehicles dangerous if engaged.”<sup>45</sup> Indeed, the Autopilot software at the center of the suit may have been at fault in at least one deadly crash.<sup>46</sup>

Further, OTA updates allow automakers to cover up sloppy manufacturing and testing outside the scrutiny of the public or regulators. NHTSA, the U.S. federal body that governs recalls and other aspects of vehicle safety, requires automakers to report safety-related defects discovered in cars. Public disclosure of these defects, and the cost of recalls, helps motivate automakers to ensure their vehicles are safe before they reach consumers. Since NHTSA cannot monitor modifications made to vehicles over the air,

<sup>42</sup> “Tesla Model 3 Falls Short of a CR Recommendation,” Patrick Olsen, *Consumer Reports*, May 2018: <https://www.consumerreports.org/hybrids-evs/tesla-model-3-review-falls-short-of-consumer-reports-recommendation/>

<sup>43</sup> “Tesla Model 3 Gets CR Recommendation After Braking Update” Patrick Olsen, *Consumer Reports*, May 2018 <https://www.consumerreports.org/car-safety/tesla-model-3-gets-cr-recommendation-after-braking-update/>

<sup>44</sup> “Tesla’s Over-the-Air Brake Upgrade Was Amazing” Timothy Lee, *Ars Technica*, May 2018: <https://arstechnica.com/cars/2018/05/how-a-software-brake-upgrade-won-tesla-a-consumer-reports-endorsement/>

<sup>45</sup> “Tesla Customers Sue Over ‘Dangerous’ And Non-Functioning Autopilot Software” Alan Ohnsman, *Forbes*, April 2017 <https://www.forbes.com/sites/alanohtsman/2017/04/19/tesla-customers-sue-over-dangerous-and-non-functioning-autopilot-software/>

<sup>46</sup> “Tesla Autopilot Was On During Deadly Mountain View Crash” Jason Green, *San Jose Mercury News*, Mar. 2018 <https://www.mercurynews.com/2018/03/30/tesla-autopilot-was-on-during-deadly-mountain-view-crash/>

automakers can easily bypass the requirement to report safety-related software updates to regulators.

Tesla's use of an OTA update to fix the brakes also raises the question: if the brakes can be fixed through a remote software update, can they be disabled by the same mechanism? To automakers, OTA updates are a huge money-saver, but to hackers, they are a wide-open door into the most sensitive software of a vehicle.

In 2017, researchers at Keen Security Lab demonstrated a way to bypass the code signing mechanism in a Tesla Model X, which is supposed to guarantee that only the manufacturer can patch the vehicle's software, suggesting a hacker could use the OTA update mechanism to disable the brakes in Tesla cars.<sup>47</sup> It might also be possible for a saboteur within Tesla to achieve the same effect. In June, 2018, in response to sabotage in Tesla's manufacturing process, Elon Musk admitted to "a long list of organizations that want Tesla to die" including oil companies and rival automakers.<sup>48</sup> Again, none of these failures is possible if the update is carried out with a qualified technician present.

#### **Anatomy and Scenarios of a Fleet-Wide Hack**

Individual cars have been hackable for many years. With physical access to a car, there's little to stop a hacker from taking control of any of its systems. However, the risks associated with such an attack are relatively minor because it only affects a single car.

Connecting cars—to each other, to the Internet, or to other insecure devices like smartphones—multiplies the danger. Suddenly, with just a little more effort, an attack that can affect one car can affect entire fleets. This creates a very effective target for terrorists, hostile nation states, or anyone else wishing to inflict a lot of damage.

Tesla CEO Elon Musk, speaking at the National Governor's Association meeting in 2017, said, "I think one of the biggest risks for autonomous vehicles is somebody achieving a fleet-wide hack."

Here are the top scenarios of a fleet-wide hack:

<sup>47</sup> "New Car Hacking Research: 2017, Remote Attack Tesla Motors Again," Keen Security Lab Blog, Jul 2017: <https://keenlab.tencent.com/en/2017/07/27/New-Car-Hacking-Research-2017-Remote-Attack-Tesla-Motors-Again/>

<sup>48</sup> "Elon Musk Emails Employees About Extensive and Damaging Sabotage Conducted By Employee," Lora Kolodny, CNBC, Jun. 2018: <https://www.cnbc.com/2018/06/18/elon-musk-email-employee-conducted-extensive-and-damaging-sabotage.html>

**Direct Attack**

In the 2015 Jeep Cherokee hack, Chris Valasek and Charlie Miller launched their attack by connecting directly to the infotainment system over the cellular network from a laptop. In addition to targeting their own Jeep Cherokee for demonstration purposes, they scanned the network for other vulnerable cars.<sup>49</sup> During one such scanning session, in a short period of time, they found 2,695 vehicles with a similar vulnerability to the one they exploited in the Jeep. Since they had already automated their attack (by programming the steps into their computer), hacking all of those vehicles directly from the same laptop would have been a trivial exercise.

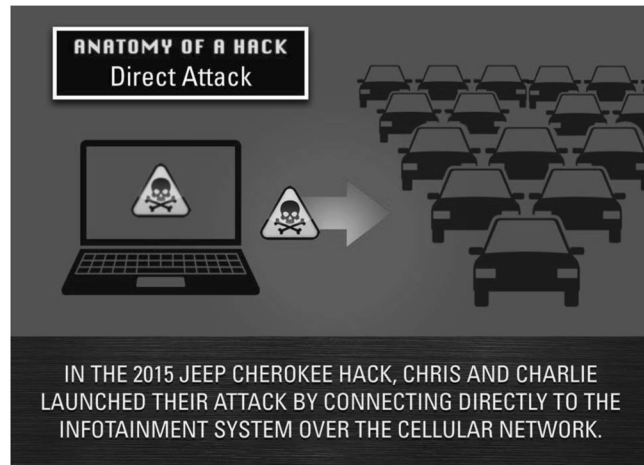

<sup>49</sup> "Remote exploitation of an unaltered passenger vehicle," Miller and Valasek, Aug. 2015: <http://illmatics.com/Remote%20Car%20Hacking.pdf>

### **Vehicle-to-Vehicle Worm**

In the paper describing their Jeep hack, Valasek and Miller hypothesized that malware could be designed to pass from vehicle to vehicle:

*"Since a vehicle can scan for other vulnerable vehicles and the exploit doesn't require any user interaction, it would be possible to write a worm. This worm would scan for vulnerable vehicles, exploit them with their payload which would scan for other vulnerable vehicles, etc. This is really interesting and scary. Please don't do this. Please."<sup>50</sup>*

Instead of directly attacking each vehicle, such an attack would only involve infecting a small number of vehicles, and allowing the malware to spread, much as a virus spreads from human to human.

Such an attack could propagate over any number of wireless media, including cellular, wifi, or using vehicle-to-vehicle (v2v) technology, which is currently under development.

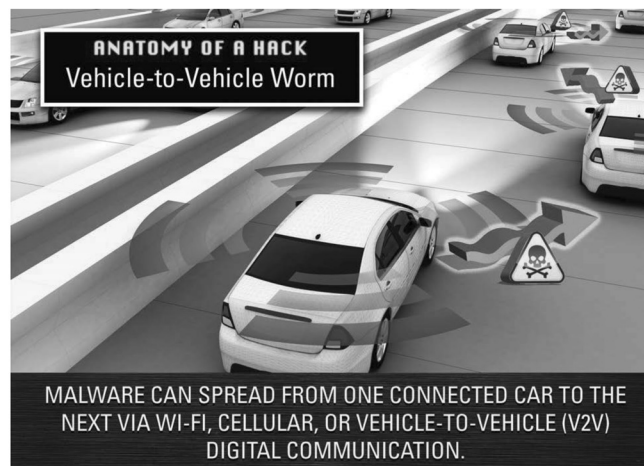

<sup>50</sup> "Remote exploitation of an unaltered passenger vehicle," Miller and Valasek, Aug. 2015: <http://illmatics.com/Remote%20Car%20Hacking.pdf>

**Home Base Attack**

Connected vehicles exchange data with the manufacturer's computers, including software updates, which are an effective way to get malware into vehicles. This means the safety of the fleet is only as good as the security of the manufacturer's corporate servers. If the same attacks successfully carried out regularly against retailers, banks, and websites are used on automobile manufacturers, it could put the manufacturer's entire fleet in jeopardy.

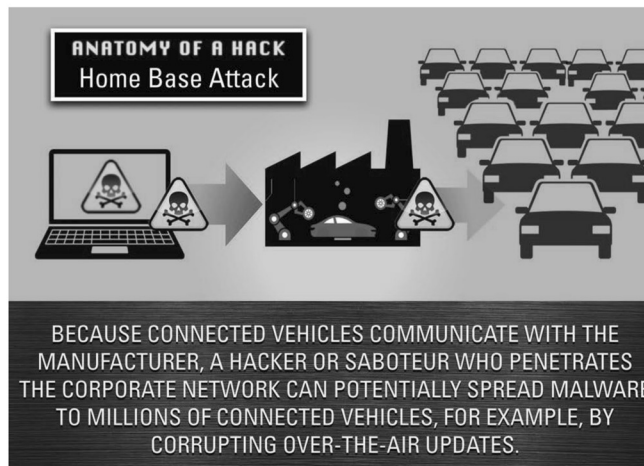

### **Wifi Hotspot Attack**

Many connected cars are equipped with wifi, and automatically connect to nearby hotspots with familiar names. For example, if you've ever previously connected to a hotspot with the name "free-wifi," then your car will likely connect to any hotspot with the same name automatically. By setting up a malicious hotspot with a common name, a hacker may be able to get cars within range to connect to it automatically, at which point the hotspot can upload malware to the car. Such an attack could be made viral by turning the wifi in infected cars into additional malicious hotspots. As cars pass each other on the highway, malware can be transferred from car to car, much as a biological virus is transmitted from human-to-human.





**Supply Chain Attack**

Most cars are built from parts from manufacturers around the world, including some countries that may be hostile to the U.S. This provides ample opportunity for malicious software to enter the production process. Such malware could sit dormant until an external stimulus, such as a signal arriving over the car's Internet connection, causes it to unleash its deadly effects.

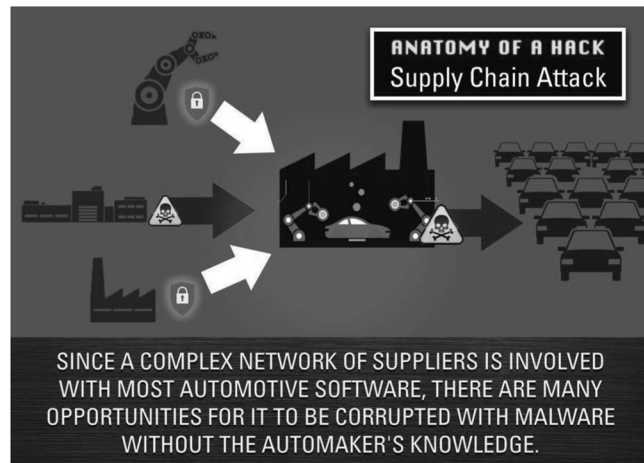

### **Digital Application Attack**

Any digital “app” you run on your car is a potential vector for malware. Security holes in the app—whether accidental or malicious—could give attackers remote access to any vehicles with the app installed. This will become increasingly common as third-party apps in cars become commonplace. We expect this to be the natural evolution of car infotainment systems as mobile operating systems like Android are more widely deployed in cars.



**Mobile-Device-to-Vehicle Attack**

It has become commonplace to connect your smartphone to your car, usually by Bluetooth. This connection allows hands-free calling while you're driving, playing audio from your phone on the car's speaker system, and other conveniences. It is also a potential vector for malware. A widespread phone virus or other phone-borne malware might not affect the phone's behavior at all, but could wait silently for your phone to pair with a car, then transfer malware to the car.



### Recent History of Car Hackings

In August 2019, at the annual Black Hat hacker conference in Las Vegas, a group of researchers from the Chinese company Keen Security Lab are scheduled to present technical details of vulnerabilities they discovered allowing hackers remote access to key systems in multiple BMW models.<sup>51</sup> BMW and other automakers want us to believe these vulnerabilities are harmless because they have now been fixed. The concern is not any individual vulnerability, but the pattern of vulnerabilities stretching back nearly a decade. This shows that, despite the auto industry's efforts and assurances, fundamental architectural problems have not been addressed, and consumers are still at risk.

*“While individual bugs are being fixed, the architectural flaws allowing these dangerous exploits remain.”*

In 2010 and 2011, researchers from University of California, San Diego and University of Washington published a pair of papers describing the vulnerability of some vehicles to remote attack.<sup>52 53</sup> The vulnerabilities remained unfixed for years. In February 2015, the attacks were demonstrated on the CBS show *60 Minutes*.

Later that year, in July 2015, two researchers, Chris Valasek and Charlie Miller, demonstrated that they could remotely attack and control a Jeep Cherokee.<sup>54</sup> Valasek and Miller published their methods in extensive detail.<sup>55</sup> Their exploit took advantage of two distinct security vulnerabilities: one allowing them remote access to the vehicle, and a second allowing remote control of the vehicle once their malicious code was “inside”. The publication of their work and the surrounding media attention forced Fiat Chrysler

<sup>51</sup> “Zero days and mitigations: roadways to exploit and secure connected BMW cars” Keen Lab & BMW <https://www.blackhat.com/us-19/briefings/schedule/index.html#-days--mitigations--roadways-to-exploit-and-secure-connected-bmw-cars-15313>

<sup>52</sup> “Experimental Security Analysis of a Modern Automobile” Koscher et. Al, University of Washington & UC San Diego, 2010 <http://www.autosec.org/pubs/cars-oakland2010.pdf>

<sup>53</sup> “Comprehensive Experimental Analyses of Automotive Attack Surfaces” Checkoway et al, UC San Diego & University of Washington <http://www.autosec.org/pubs/cars-usenixsec2011.pdf>

<sup>54</sup> “Hackers Remotely Kill Jeep on the Highway” Andy Greenberg, *Wired*, July 2015: <https://www.wired.com/2015/07/hackers-remotely-kill-jeep-highway/>

<sup>55</sup> “Remote exploitation of an unaltered passenger vehicle” Miller and Valasek, Aug. 2015: <http://illmatics.com/Remote%20Car%20Hacking.pdf>

Automobiles (FCA) to recall not just the 2014 Jeep Cherokee used in the demonstration, but a broad range of models, totaling approximately 1.4 million vehicles.<sup>56</sup>

It is not surprising the security holes that allowed the exploit were not limited to one model. There is a strong economic incentive for automakers and their suppliers to reuse software to the greatest extent possible. The result is a monoculture that makes the fleet of cars more susceptible to cyber-attack, just as an ecological monoculture makes a biological population more susceptible to disease.

The FCA recall demonstrated that a single vulnerability can affect in excess of one million vehicles. The vulnerability that gave the researchers control of the vehicle was an architectural flaw, that would have been extremely costly for FCA to fix. Evidence suggests that it was not addressed in the recall, which only applied to vehicles with a particular version of the "Uconnect" system, the infotainment system containing the first vulnerability, through which Valasek and Miller gained access to the Jeep<sup>57</sup>. As one anonymous industry expert explained, "It's cheaper to use chewing gum and duct tape to plug holes than to really fix the problem."

Other vehicles that likely had the architectural flaw were not recalled, and it is very unlikely the flaw was fixed in any vehicle. As a result, a year after the recall, Valasek and Miller were still finding and demonstrating increasingly dangerous vulnerabilities.<sup>58</sup> In Miller's words, "There's no reason to think the bug we found and got patched last year is the only bug of its kind. There are definitely more vulnerabilities in other cars, and probably more in the Jeep, too."<sup>59</sup>

Recent events support Miller's assertion. Keen Security Lab demonstrated similar vulnerabilities in Tesla vehicles in 2016, and then again a year later, according to a July 2017 press release.<sup>60</sup> This is the same organization that will present its BMW vulnerability findings later this year.

<sup>56</sup> "After Jeep hack, Chrysler recalls 1.4 million vehicles for bug fix," Andy Greenberg, *Wired Magazine*, July 2015: <https://www.wired.com/2015/07/jeep-hack-chrysler-recalls-1-4m-vehicles-bug-fix/>

<sup>57</sup> "Protect Your Chrysler, Dodge, or Jeep From Hacking," Linkov and Yu, *Consumer Reports*, July 2015: <https://www.consumerreports.org/cro/news/2015/07/protect-your-chrysler-dodge-or-jeep-from-hacking/>

<sup>58</sup> "Jeep Hackers Are Back To Prove Car Hacking Can Get Much Worse," Andy Greenberg, *Wired*, Aug. 2016: <https://www.wired.com/2016/08/jeep-hackers-return-high-speed-steering-acceleration-hacks/>

<sup>59</sup> "Jeep Hackers Are Back To Prove Car Hacking Can Get Much Worse," Andy Greenberg, *Wired*, Aug. 2016: <https://www.wired.com/2016/08/jeep-hackers-return-high-speed-steering-acceleration-hacks/>

<sup>60</sup> "New Car Hacking Research: 2017 Remote Attack Tesla Motors Again," Keen Security Lab of Tencent, July 2017: <https://keenlab.tencent.com/en/2017/07/27/New-Car-Hacking-Research-2017-Remote-Attack-Tesla-Motors-Again/>

The steady pace of these demonstrations over the course of a decade is evidence that the industry is not substantially improving security. While individual bugs are being fixed, the architectural flaws allowing these dangerous exploits remain.

See the timeline below for a sampling of significant events in the recent history of car hacking.

#### Timeline of Notable Car Hacks



**MAY 2010** — Researchers from UCSD and UW publish “Experimental Security Analysis of a Modern Automobile” in which they describe their research taking control of vehicles through their electronics. They do not identify the make of the vehicle in the paper (“We believe the risks identified in this paper arise from the architecture of the modern automobile and not simply from design decisions made by any single manufacturer. For this reason, we have chosen not to identify the particular make and model used in our tests.”) However, it has since been revealed as a 2009 Chevy Impala.<sup>61</sup>

**AUGUST 2011** — The same researchers from UCSD and UW publish “Comprehensive Experimental Analyses of Automotive Attack Surfaces” in which they extend their past work to cover remote attacks, and describe the possibility of such attacks against several makes. Their experimental research was performed on a Chevy Impala. GM did not fix the vulnerabilities until 2015.<sup>62</sup>

**JULY 2013** — Researchers Charlie Miller and Chris Valasek demonstrate vulnerabilities in a Toyota Prius and a Ford Escape, including the ability to electronically disable the brakes. The demonstration requires physical access to the vehicle, but lays the groundwork for their later work.<sup>63</sup>

**FEBRUARY 2015** — Remote car-hacking demonstration on CBS’ “60 Minutes”. The target vehicle is a Chevy Impala, attacked through its OnStar telematics system, though that was not disclosed in the video.<sup>64</sup>

**JULY 2015** — Charlie Miller and Chris Valasek demonstrate remote takeover of an unmodified Jeep Cherokee over the Internet for *Wired* Magazine, leading to the

<sup>61</sup> <http://www.autosec.org/pubs/cars-oakland2010.pdf>

<sup>62</sup> <http://www.autosec.org/pubs/cars-usenixsec2011.pdf>

<sup>63</sup> <https://www.forbes.com/sites/andygreenberg/2013/07/24/hackers-reveal-nasty-new-car-attacks-with-me-behind-the-wheel-video/>

<sup>64</sup> <https://www.cbsnews.com/news/car-hacked-on-60-minutes/>

recall of 1.4 million vehicles.<sup>65</sup>

JULY 2015 — At the DEF CON security conference, hacker Samy Kamkar demonstrates a small, inexpensive box he designed that allows taking control of GM vehicles.<sup>66</sup>

AUGUST 2015 — Kevin Mahaffey and Marc Rogers publish numerous vulnerabilities in a Tesla Model S.<sup>67</sup>

AUGUST 2015 — Researchers from UCSD demonstrate activating and disabling a Corvette's brakes using a common insurance company dongle.<sup>68</sup>

OCTOBER 2015 — Researcher Craig Smith, author of "The Car Hacker's Handbook," demonstrates a vulnerability affecting almost any make of car, in which the attack affects tools used by dealers and repair shops.<sup>69</sup>

MARCH 2016 — **FBI issues public service announcement warning about cyberattacks against connected cars.**<sup>70</sup>

AUGUST 2016 — Charlie Miller and Chris Valasek demonstrate additional, and potentially more deadly vulnerabilities in the same Jeep Cherokee they hacked a year earlier, even though it had been patched.<sup>71</sup>

SEPTEMBER 2016 — Keen Security Lab, a subsidiary of Chinese conglomerate Tencent, demonstrates remote takeover of a Tesla Model S, including remote control of the brakes.<sup>72</sup>

<sup>65</sup> <https://www.wired.com/2015/07/hackers-remotely-kill-jeep-highway/>

<sup>66</sup> <https://samy.pl/defcon2015/>

<sup>67</sup> <https://blog.lookout.com/hacking-a-tesla>

<sup>68</sup> <https://www.wired.com/2015/08/hackers-cut-corvettes-brakes-via-common-car-gadget/>

<sup>69</sup> <https://www.wired.com/2015/10/car-hacking-tool-turns-repair-shops-malware-brothels/>

<sup>70</sup> <https://www.ic3.gov/media/2016/160317.aspx>

<sup>71</sup> <https://www.wired.com/2016/08/jeep-hackers-return-high-speed-steering-acceleration-hacks/>

<sup>72</sup> <https://keenlab.tencent.com/en/2016/09/19/Keen-Security-Lab-of-Tencent-Car-Hacking-Research-Remote-Attack-to-Tesla-Cars/>

JULY 2017 — Keen Security Lab remotely takes over a Tesla Model X.<sup>73</sup>

FEBRUARY 2018 — Researchers at University of Michigan, Dearborn publish “State-of-the-Art Survey on In-Vehicle Network Communication “CAN-Bus” Security and Vulnerabilities.”<sup>74</sup>

APRIL 2018 — Researchers Daan Keuper and Thijs Alkemade find flaws in the VW Golf GTE and Audi A3 e-tron allowing attackers to track the vehicle, listen to conversations taking place in the vehicle, and access the address book and communication history. The researchers stopped short of attempting to manipulate safety-critical systems, citing fear of prosecution under anti-hacking laws.<sup>75</sup>

MAY 2018 — Keen Security Lab publishes a whitepaper describing over a dozen vulnerabilities affecting BMWs.<sup>76</sup>

DECEMBER 2018 — Upstream, an automotive cybersecurity company, releases “Global Automotive Cybersecurity Report 2019.” As of May 28, 2019, the repository of smart mobility cyberattacks on their website documented 276 cases.<sup>77</sup>

JANUARY 2019 — *Consumer Reports*: “As cars get more connected, the industry is trying to stay ahead of multiplying threats.”<sup>78</sup>

FEBRUARY 2019 — Researchers Vivek, Yanni, and Yunker from Georgia Institute of Technology publish a paper in which they determine the percentage of cars that would need to be hacked to create gridlock in New York City. Their research shows that hacking cars of a single make during rush hour would probably cause a “city-wide disruption” of traffic.<sup>79</sup>

<sup>73</sup> <https://keenlab.tencent.com/en/2017/07/27/New-Car-Hacking-Research-2017-Remote-Attack-Tesla-Motors-Again/>

<sup>74</sup> <https://arxiv.org/abs/1802.01725>

<sup>75</sup> <https://threatpost.com/volkswagen-cars-open-to-remote-hacking-researchers-warn/131571/>

<sup>76</sup> <https://keenlab.tencent.com/en/2018/05/22/New-CarHacking-Research-by-KeenLab-Experimental-Security-Assessment-of-BMW-Cars/>

<sup>77</sup> <https://www.upstream.auto/news/press-release-global-automotive-cybersecurity-report-2019/>

<sup>78</sup> <https://www.consumerreports.org/automotive-technology/companies-target-the-next-car-hack-attack/>

<sup>79</sup> <https://arxiv.org/abs/1903.00059>





MARCH 2019 — Hackers Richard Zhu & Amat Cama demonstrate a security hole in a Tesla Model 3 at the annual “pwn2own” hacking competition in Vancouver, BC.<sup>80</sup>

MARCH 2019 — Keen Security Lab publishes a paper describing exploitation of a Model S Autopilot unit to take wireless control of the car. In the same paper, they demonstrate placing reflective stickers on the road to fool Autopilot into swerving into oncoming traffic.<sup>81</sup>

APRIL 2019 — Researcher Scott Gayou demonstrates breaking into the StarLink head unit, used in multiple Subaru models, including publishing details and source code online.<sup>82</sup>

AUGUST 2019 — Researchers from Keen Security Lab will reveal details of the vulnerabilities they found in BMWs at the annual Black Hat hacker conference in Las Vegas.<sup>83</sup>

#### Profits Over Security and Safety

One might assume that the automotive industry’s unwillingness to invest in cyber-safety is the result of a failure to realize that secure software is now critical to automotive safety. While that is possible, there are other ways to explain the industry’s behavior.

One possibility is that the automotive industry is in a state of Nash Equilibrium, in which all of the major automakers recognize the danger, but none has the motivation to make a unilateral change. Investing in security improvements can cause an automaker to lose ground in the marketplace, as security improvements divert valuable engineering resources away from the development of customer-visible features. If a cyber-attack occurs, while it could affect multiple models, it is likely to affect only a single vehicle make. Hardware and software is different enough from one automaker to the next that an attack affecting one make would likely be ineffective against others. Since even the most successful automaker controls less than 20% of the U.S. market, it is each automaker’s

<sup>80</sup> <https://www.zdnet.com/article/tesla-car-hacked-at-pwn2own-contest/>

<sup>81</sup> <https://www.forbes.com/sites/thomasbrewster/2019/04/01/hackers-use-little-stickers-to-trick-tesla-autopilot-into-the-wrong-lane/>

<sup>82</sup> <https://hackaday.com/2019/04/16/jailbreaking-a-subaru-qnx/>

<sup>83</sup> <https://www.blackhat.com/us-19/briefings/schedule/#0-days-mitigations-roadways-to-exploit-and-secure-connected-bmw-cars-15313>

best strategy to wait until an attack occurs.<sup>84</sup> For any given automaker, such an attack would more likely than not affect part of the 80+% of the market controlled by their competitors. At that point, the government would likely impose regulations on the whole industry, without any individual automaker suffering a competitive disadvantage. Thus, it

*“It is to each automaker’s advantage to avoid making any large investments towards fixing security until their hand is forced by regulation, consumer outcry, or some other external inducement.”*

is to each automaker’s advantage to avoid making any large investments towards fixing security until their hand is forced by regulation, consumer outcry, or some other external inducement.

Another factor influencing automakers’ adoption of connected technology is the allure of surveillance capitalism. With the auto industry concerned about layoffs and a global drop in demand for cars<sup>85</sup>, they are understandably looking for other sources of revenue. Monetizing the information your car knows about you<sup>86</sup> is an obvious way to do that.

“We live in an era of constant total commercial surveillance,” said Alastair Mactaggart, proponent of a ballot measure that inspired the toughest online privacy law in America—the California Consumer Privacy Act. “You need a cell phone just to survive in today’s world, and yet your phone tracks you more thoroughly than any ankle monitor since your phone knows your thoughts and your interests. Your car knows how much you weigh, how often you speed, when you eat at a fast food restaurant, and how long you stay at the gym.”<sup>87</sup>

Surveillance capitalism has made the richest and most powerful corporations in the world—Facebook, Google, Amazon—who and what they are. Carmakers, like every industry, have taken note of the money to be made from selling our private information to the

<sup>84</sup> “Selected Automakers U.S. YTD Market Share in 1st quarter of 2019.” *Statista*: <https://www.statista.com/statistics/343162/market-share-of-major-car-manufacturers-in-the-united-states/>

<sup>85</sup> “The pain is just beginning: After 38,000 layoffs, Wall Street wakes up to ‘peak car.’” Jim Edwards, *Business Insider*, Jun. 2019: <https://www.businessinsider.com/peak-car-38000-layoffs-job-losses-sales-at-auto-makers-2019-5>

<sup>86</sup> “What your car knows about you,” Christina Rogers, *Wall Street Journal*, Aug. 2018: <https://www.wsj.com/articles/what-your-car-knows-about-you-1534564861>

<sup>87</sup> Alastair Mactaggart receiving Consumer Watchdog’s Citizen Activist of the Year Award at The Rage for Justice Awards, May 18, 2019, Beverly Wilshire Hotel. <https://www.youtube.com/watch?v=Ow879bRUkv4&t=18s>

highest bidders. GM ran a pilot program in late 2017 in which they harvested data from 90,000 connected cars, looking for ways to monetize it.<sup>88</sup> In a 2018 interview, Ford CEO Jim Hackett suggested his company could make money cross-referencing what your car knows about you with auto loan data:

*“We already know and have data on our customers. By the way, we protect this securely; they trust us. We know what people make. How do we know that? It’s because they borrow money from us. And when you ask somebody what they make, we know where they work; we know if they’re married. We know how long they’ve lived in their house, because these are all on the credit applications. We’ve never ever been challenged on how we use that. And that’s the leverage we’ve got here with the data.”<sup>89</sup>*

The desire for larger, easier profits from data-mining our cars is clear motive for automakers to connect all vehicles to the Internet in spite of the risks to consumers. The commercial value of where, when, and how we drive, and to what media we’re exposed along the way is a gold mine. Car executives are well aware that the revenue associated with data collection from surveillance capitalism could exceed the margins to be made from making and selling the cars themselves.

Automakers’ focus on profits also calls into question their commitment to maintaining automotive software into the future. Carmakers’ solution to keeping connected cars secure is frequent software patches. Even if such an approach were effective, the average lifespan of a new car is about 11 years, and cars frequently remain in use for 20 years or more.<sup>90</sup> What will happen to your Internet-connected car when it no longer makes economic sense for the automaker to keep patching the software? This could result in the same “planned obsolescence” that we’ve seen with smartphones, PCs, and other consumer electronics. By reducing the lifespan of cars, this could boost auto sales at consumers’ expense.

In 2016, Ashkan Soltani, while chief technologist for the Federal Trade Commission wrote, “If consumers are already exposed to security updates and end-of-life issues in more mature markets for routers and smartphones, one has to wonder what the security

<sup>88</sup> “GM’s data mining is just the beginning of the in-car advertising blitz,” Andrew Hawkins, *The Verge*, Oct. 2018: <https://www.theverge.com/2018/10/17/17990052/gm-radio-listen-tracking-habits-advertising-future>

<sup>89</sup> “Can an Industrial Giant Become a Tech Darling? (Ep. 357)” Stephen Dubner, *Freakonomics*, Nov:2018: <http://freakonomics.com/podcast/ford/>

<sup>90</sup> “America’s Cars and Trucks are Getting Older,” Wolf Richter, *Business Insider*, Aug 2018 <https://www.businessinsider.com/americas-cars-and-trucks-are-getting-older-2018-8>

implication will be like of this new and rapidly emerging market of IoT.<sup>91</sup> Indeed, people will undoubtedly continue to drive connected cars after the maker stops supporting the software. Technologists contend that while it is practically impossible to secure a car manufactured today from today's hackers, it is ludicrous to expect a car manufactured today to be safe from hackers two decades from now. Without a way to disconnect the cars from the Internet, they will be vulnerable, creating a public safety risk. To date, the auto industry has not offered any viable solution to this problem.

### Potential Damage from a Large-Scale Hack

Consider a hypothetical attacker who wants to cause as many casualties as possible. The attacker would most likely attempt a coordinated attack on as many vehicles as possible, to ensure a minimum of warning. Since infecting millions of vehicles simultaneously is probably not feasible, the attacker would more likely infect the vehicles over a period of weeks or months prior to the attack with malware that is programmed to activate at a specific day and time, or in response to an external signal. Such an infection could be achieved through the OTA update mechanism, using a virus or worm<sup>92</sup>, or by any number of other means. Some vehicles may escape infection, so we will assume an 80% infection rate.

Only a fraction of infected vehicles would be on the road at

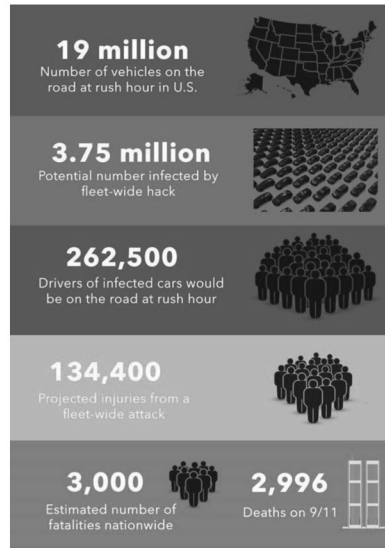

<sup>91</sup> "What's the Security Shelf Life of IoT?" Ashkan Soltani, Federal Trade Commission, Feb. 2015 <https://www.ftc.gov/news-events/blogs/techftc/2015/02/whats-security-shelf-life-iot>

<sup>92</sup> "Remote Exploitation of an unaltered passenger vehicle," Valasek and Miller, page 48, August 2015 <http://illmatics.com/Remote%20Car%20Hacking.pdf>

*“It could affect the evening ‘rush hour’ across all four continental U.S. time zones, when the number of vehicles on the road peaks at around 19 million, or approximately 7% of the entire U.S. fleet.”*

any one time, so the attacker would pick a time of maximum traffic. If the attack occurred at 4pm Pacific Time on a weekday, it could affect the evening “rush hour” across all four continental U.S. time zones, when the number of vehicles on the road peaks at around 19 million, or approximately 7% of the entire U.S. fleet<sup>93</sup>.

A hypothetical attack could disable the brakes and airbags in affected vehicles. Both are feasible once the CAN bus is compromised. Even mechanical brakes can be overridden by tricking the anti-lock mechanism into activating, or by “bleeding” the brakes while the vehicle is moving. Bleeding eliminates air bubbles from the brake hydraulics, with the side effect of making the brakes ineffective for a period. Valasek and Miller used the latter technique in their 2015 hacking demonstration.<sup>94</sup> A method of disabling the airbags was publicized in 2017 that is both impossible to patch and difficult for intrusion detection systems to detect.<sup>95</sup> The attack could also affect steering and acceleration in vehicles in which they are electronically controlled.

The attack is not guaranteed to cause an accident in every car, but might result in 80% of infected vehicles on the road involved in a collision. Statistically, in the U.S., there is one fatality per approximately 200 auto accidents.<sup>96</sup> Based on these numbers alone, we can expect one fatality per approximately 4500 vulnerable vehicles. While that does not sound very scary, with millions of vulnerable connected cars on the road, the death toll could feasibly be in the thousands.

Further, this estimate does not consider malicious intent. The number of fatalities could be much higher with airbags electronically disabled, and vehicles intentionally

<sup>93</sup> “Summary of Travel Trends, 2009 National Household Travel Survey,” U.S. Department of Transportation <https://nhts.ornl.gov/2009/pub/stt.pdf> (page 52)

<sup>94</sup> “Remote Exploitation of an Unaltered Passenger Vehicle,” Valasek and Miller, August 2015: <http://illmatics.com/Remote%20Car%20Hacking.pdf>

<sup>95</sup> “How secure is your car? Unpatchable flaw lets attackers disable safety features,” Liam Tung, *ZDnet*, Aug 2017: <https://www.zdnet.com/article/how-secure-is-your-car-unpatchable-flaw-lets-attackers-disable-safety-features/>

<sup>96</sup> “Traffic Safety Facts 2016 Data,” National Highway Traffic and Safety Administration, Sept 2018: <https://crashstats.nhtsa.dot.gov/Api/Public/ViewPublication/812580>

manipulated to cause maximum damage. Emergency services could be overwhelmed by a large-scale attack, resulting in slower response to the critically injured.

It's hard to predict how these factors would affect the fatality rate, but it's reasonable to assume it could rise as high as 1 fatality per 1000 affected vehicles. Each of the top automakers sells around three million cars in the U.S. each year. If only one model year is affected by the hack, we can still expect about 3,000 deaths—about the same as 9/11.<sup>97</sup> If multiple model years are involved, which is quite possible as major model upgrades only happen every 4-6 years, the number of deaths could be several times 9/11.

#### **The Future of Auto Safety: The Kill Switch & Beyond**

The best fix is to ensure there is no electronic connection between the cellular-accessible components and the safety-critical components in the vehicles. This “air gap” method is time-tested and very effective, as no matter how buggy the software, a hacker cannot cross the air gap from the remotely-accessible components to the components that control the car's motion.<sup>98</sup>

In most cars, the biggest downside of such a change is that it would be impossible to OTA update the software controlling safety-critical systems. As explained above, these safety-critical software updates are better done under a mechanic's supervision anyway, and disallowing OTA updates of safety-critical systems creates an economic incentive for carmakers to engineer their software more carefully. Unfortunately, if all automakers began redesigning their cars today to air-gap the safety-critical components, it would take 4-5 years for the new, safer vehicles to show up in the showroom. This means it would take approximately 18 years before even half the vehicles on the road had the new air-gap security architecture.<sup>99</sup>

An even simpler, safer fix is to remove all vehicles from the cellular network until the air-gapped security architecture described above can be rolled out. There are very few features for which cars require access to the outside world, and most of them have viable (albeit sometimes less convenient) alternatives. For example, in-dash navigation systems might use a network connection to access live traffic data, but dash-mounted smartphones can provide an equivalent capability without posing an undue risk to the car's cyber-safety.

<sup>97</sup> “September 11 Terror Attack Fast Facts” CNN, Sept 2018: <https://www.cnn.com/2013/07/27/us/september-11-anniversary-fast-facts/>

<sup>98</sup> “Air Gap (Networking)” Wikipedia, [https://en.wikipedia.org/wiki/Air\\_gap\\_\(networking\)](https://en.wikipedia.org/wiki/Air_gap_(networking))

<sup>99</sup> “How long does it take for 50% of cars to comply with a new law?” *Fleetcarma*, Dec 2015 <https://www.fleetcarma.com/cars-new-law-timeline/>

The auto industry has existed for more than a century. Only in the last few years have we begun making cars remotely accessible via computer networks. It is therefore very unlikely that the features made possible by the “connected car” are things we cannot live without, at least until we can develop a safer way to implement them.

The most cost effective and practical approach to cybersecurity is the inclusion in every connected car of a “kill switch”—a low tech device that allows every driver to disconnect their vehicle from the Internet. The approximate cost of such a device is 50 cents or less. Automakers should commit to include a kill switch in every car they produce until they develop long term security solutions needed to combat this threat. If carmakers don’t make such a commitment by the end of this year it should be mandated by Congress and safety regulators.

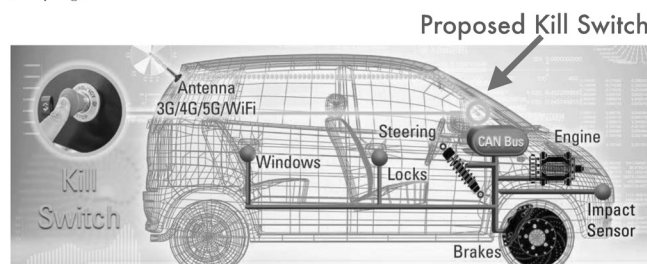

The greatest value of the kill switch would be to help restart the transportation infrastructure after a massive cyberattack. After 9/11, air traffic in the U.S. was shut down for several days while we implemented new security and verified that we could resume flying safely. In the aftermath of an automotive cyberattack, ensuring the safety of hundreds of millions of connected cars with "always-on" Internet connections could take months, during which time our economy and our ability to move necessities such as food across the country would be crippled. However, if cars were required to have the ability to disconnect from the Internet, we could restore our transportation infrastructure with the flip of a switch.

In addition to equipping every connected car in America with a “kill switch” that disconnects the safety-critical systems from the Internet and wide-area connections, the car industry should respond immediately with more transparency and consumer control.

If carmakers will not commit to equipping every vehicle with a kill switch by December 31, 2019, legislators and regulators should mandate these protections.

Given the auto industry's reluctance to submit to regulations and disclosure, federal and state regulators will likely have to take actions to force automakers to be transparent about their safety protocols.

In the short term, regulators should require automakers to publicly disclose the authorship, safety certifications, and testing methodology used for all safety- and security-critical software, allowing for analysis by independent regulatory and testing agencies.

CEOs of auto manufacturers should be required to sign personal statements and accept personal legal liability for the cyber-security status of their cars.

A precept that governs the industry standards should be that cars should not be connected to wide-area networks until they can be proven immune to hackers. If voluntary standards are not in the service of this imperative, then government at every level must act to insure this is the social more and legal standard that automakers live up to.

New car designs take three to five years to reach consumers. At the earliest possible implementation date, future designs should completely separate safety-critical systems from any device communicating with the Internet or other networks. Connecting safety-critical systems to the Internet is inherently dangerous design. Automakers must submit to this premise if safety on American roads is to be preeminent.



**APPENDIX: Key Answers From Top Engineers*****If cars are at risk, why haven't we seen reports of hackers taking control of cars "in the wild"?***

Most hackers are motivated by money, and in recent years, we have indeed seen a startling rise in "electronic" car theft, usually involving keyless entry systems. Attacks that take control of a car's movement cause physical harm and property damage, but generally aren't profitable, so are less interesting to most hackers. Such attacks are mainly of interest to terrorists and hostile nation states, and, while much less common, are likely to come at large scale and without warning.

***If the chance of a massive coordinated attack are low, why should we be concerned?***

It only takes one large-scale attack to cost thousands of lives, disrupt our economy, and start wars. Given simple steps to prevent such an attack, it would be irresponsible not to take them. As an analogy, the chance of your home burning down may be small, but carrying homeowner's insurance is still a good idea.

***Why would a hostile entity attack us through our cars? Aren't conventional weapons, such as bombs, more reliable?***

An Internet-based attack has several potential advantages. Automaker "bug bounty" programs have demonstrated that vulnerabilities can be bought for a few tens of thousands of dollars, which is much cheaper than conventional weapons. Internet-based attacks also do not require physical presence on foreign soil, and can be nearly impossible to trace back to their source. A clever hacker could even make it look like a third party was responsible.

***Is it possible to prove a car to be immune from cyber-attack?***

The auto industry has existed for more than a century, and for most of that history, cars have been provably immune to cyber-attack because they weren't connected to the Internet. Maintaining physical separation (an "air gap") between Internet-connected components and safety-critical components is a way to allow most of the benefits of connectivity (live traffic reports, Internet-based communication and entertainment, etc.) without putting the movement of the car at risk. These are low-tech, low-cost options that work when implemented correctly.

***Doesn't an Internet connection improve security by allowing manufacturers to keep our cars up-to-date with the latest security patches?***

Yes, keeping software up-to-date is a good thing, and Internet connectivity makes it simpler, easier, and more reliable to do that. However, every software update you receive on your smartphone or other connected gadget means the previous version of the software wasn't finished. That's fine when novelty is more important than safety, such as on a tablet or smartphone. But when you buy a new car, do you really want the brakes operating on unfinished software?

It is the automakers' responsibility to ensure the most critical automotive software is working correctly before it leaves the factory, or else consumer safety is at risk. If critical software requires an update, the automakers' safety and quality control processes have failed. Allowing automakers to update critical software frequently, easily, and away from public and regulatory attention only serves to cover up a serious public safety hazard.

Senator MARKEY. In response to this news, Senator Blumenthal and I sent a letter to NHTSA asking the Agency to share any information it has about these cyber risks and any actions it's taking to protect consumers.

Dr. Owens, NHTSA still hasn't responded to our letter. So please respond to my question now. Should consumers be told about the cyber risks of their Internet-connected cars? Yes or no? Investors are told of the risks, consumers are not. Should consumers also be told of the risks?

Dr. OWENS. Senator, every computer is potentially vulnerable to cybersecurity risk. So—

Senator MARKEY. I know that. And so, don't investors—because the investors are told of the risks, should consumers be told of the risks?

Dr. OWENS. Senator, if we determine that there is a cybersecurity incident or risk that poses a risk to safety, we will conduct a recall and that will—and that is a public action and the public will be aware of an identified incident or vulnerability. We did so in 2015, we recalled 1.4 million vehicles for a cybersecurity vulnerability that we identified.

Senator MARKEY. Well the, the problem is that they feel they have an obligation to notify investors and shareholders of these defects in the vehicle. Why don't you make sure that they notify consumers of the same defects in these vehicles?

Obviously it's relevant information that the automakers have to disclose with regard to the safety of the vehicles, who better to get the information than consumers. So I just urge you very strongly and we're going to be on you and answer our letter. Answer the letter that Senator Blumenthal and I have sent you. Will you do that?

Dr. OWENS. Yes, Senator, we will.

Senator MARKEY. And when will you get that back to us?

Dr. OWENS. As soon as we can.

Senator MARKEY. Yes, that's not a good answer given that we've waited since August. That's why actually in addition, Senator Blumenthal and I had introduced a Spy Car Act that directs NHTSA to establish Federal cybersecurity standards to secure our cars. Thank you, Mr. Chairman.

The CHAIRMAN. Do you think you might be able to get an answer within two weeks to that letter Dr. Owens?

Dr. OWENS. In my time in government, I've come to hesitate about giving deadlines because I inevitably get it wrong. But I can assure you we want to get this out as soon as we can.

The CHAIRMAN. Try to try to do that within a couple of weeks.

Senator MARKEY. Thank you Mr. Chairman.

The CHAIRMAN. If you don't mind. Well, it's been a good hearing and we have a vote on and we're going to close the hearing at this point.

I think a healthy degree of skepticism is always good. At the same time, I think a decade or two from now we'll look back and be amazed that there was ever a question that AVs will save lives and make the traveling public safer. It does. Let me just ask all three of you.

Is there any question in your minds that, that we are headed toward a dramatic reduction in accidents and in traffic fatalities as we move forward with AVs? Is there any question? Mr. Szabat?

Mr. SZABAT. Senator, no.

The CHAIRMAN. Dr. Owens?

Dr. OWENS. We don't have any questions about that.

The CHAIRMAN. And Mr. Sumwalt, you can't answer with one word so elaborate because you're such a great witness.

Mr. SUMWALT. Well, thank you. I do think that it holds great promise to improve safety, but it has to be done properly.

The CHAIRMAN. Absolutely. Absolutely. Well, I want to thank the witnesses and all the members for really, really good questions.

The hearing record will remain open for two weeks as usual. During this time Senators are asked to submit any questions for the record. Upon receipt, the witnesses are requested to submit their written answers to the Committee as soon as possible, but no later than Wednesday, December 12, 2019.

And Dr. Owens there is a common frustration among members of the House and Senate at getting letters answered. So do the best, your absolute best you possibly can, in responding to Senator Markey's request. And I now conclude the hearing and announce that we are adjourned.

Thank you all.

[Whereupon, at 11:47 a.m., the hearing was adjourned.]

# A P P E N D I X

CONSUMER TECHNOLOGY ASSOCIATION  
*November 18, 2019*

Chairman Wicker and Ranking Member Cantwell  
Senate Committee on Commerce, Science, and Transportation

Dear Chairman Wicker and Ranking Member Cantwell;

In advance of the Senate Committee on Commerce, Science, and Transportation hearing on automated vehicles, the Consumer Technology Association (CTA)<sup>®</sup> would like to highlight our support for a Federal self-driving vehicles bill. We applaud the leadership of the committee to work together in a bipartisan manner to advance legislation addressing self-driving vehicles. Self-driving vehicles (SDVs) will save thousands of lives a year on our highways and deliver life-changing freedom and independence to seniors and people with disabilities—but we must have the right laws in place.

CTA represents the entrepreneurs, technologists and innovators molding the future of the consumer technology industry. Our more than 2,200 member companies include many working to transform the safety and efficiency of the driving experience through automated driving technologies and assisted and self-driving cars.

One of the biggest challenges facing the development and implementation of these technologies is the growing patchwork of legislation and regulation across the country. Federal and state governments have different roles in the deployment of SDVs—and the expanding patchwork of local rules across the country will only delay SDV testing and hinder America’s global leadership. A ‘technology-neutral’ approach to SDV rules is also critical to allow new innovators to enter the SDV sector, develop safer technologies, and provide greater efficiencies.

Below are our key priorities for legislation related to self-driving vehicles.

Rulemakings, including updating existing standards and setting new standards;

- The current Federal Motor Vehicle Safety Standards (FMVSS) were established when the driving task was assumed to be performed by a human driver and, as a result, are typically drafted in a way that directly or indirectly refers to vehicle controls being operated by a human. SDV design may not revolve around a human driver in the vehicle. As such, current FMVSS limit the ability to make significant changes to vehicle design, which can preclude truly innovative approaches to fully self-driving vehicles.
- While exemptions will provide some relief in the short term, they are not a permanent solution. NHTSA needs to evaluate the FMVSS and update outdated standards before SDVs can be deployed widely. We must retain flexibility for NHTSA to update existing FMVSS to allow for self-driving vehicles, create new FMVSS, or a combination of both options. Additionally, NHTSA will need to update its test procedures for certifying compliance in a world where humans are not always the direct operators. A timeline from NHTSA detailing what steps the industry will take when will be important for long term planning.
- NHTSA should work in conjunction with the broad AV industry and leading standards bodies to collaboratively develop technology-neutral and transparent best practices and industry standards.
- Expedited rulemaking should apply to both passenger and passenger-less vehicles.

Federal, State and Local Roles and access to courts;

- The Federal Government is responsible for vehicle safety and performance standards (FMVSS), recalls, and issuing guidance for manufacturers to follow. States are responsible for regulating insurance, adjudication of liability, vehicle safety inspection, vehicle registration, human driver licensing requirements, and enacting and enforcing traffic laws. Any legislation must clarify this divi-

sion of responsibility and ensure the Federal Government is solely responsible for regulating vehicle safety and performance standards.

- CTA strongly opposes any provision limiting the use of arbitration, a legal mechanism widely used to reduce the cost of litigation for both companies and consumers, and to provide more timely remedies for everyone involved in a dispute. There is no clear public policy purpose to address it narrowly in the context of self-driving vehicles, nor is it appropriate to make changes to the Federal Arbitration Act in this bill.

#### Exemptions;

- NHTSA has the authority to exempt vehicles from existing FMVSS to allow for testing of new vehicle designs and safety features, and for the limited sale of such vehicles. Exemptions are currently available to vehicle manufacturers only on a temporary basis, typically two-three years, and only a small number (2,500) of exemptions are available. Expanding NHTSA's exemption authority would allow manufacturers and other entities to gather the data they need to improve safety and performance, while preserving the agency's oversight authority through the terms and conditions of individual exemptions.
- For many manufacturers, it is not economically feasible to build a manufacturing line for 2,500 vehicles or less. This hinders American competitiveness by disadvantaging U.S. companies against foreign competitors, like China, that do not have such limitations and whose companies can invest freely at scale.
- The exemption process must be available to all petitioners (*e.g.*, traditional OEMs, suppliers, tech companies, and new entrants) on a level playing field.
- Decisions on exemption petitions should be timely.
- Exemptions should be applicable for crashworthiness standards as well as crash avoidance and post-crash standards.

#### Testing Expansion;

- Expand eligibility of the FMVSS testing exemption created in the FAST Act (40 USC 30112) to provide parity among automobile manufacturers (OEMs), suppliers, manufacturers of ADS components, and developers of automated driving vehicles and automated driving systems (ADS).
- Testing, evaluation and/or demonstration of a SDV should be completed only by the respective employee(s), agent(s) or fleet management contractors of the manufacturer under this exemption.

#### Advisory Committees;

- Any advisory committee should ensure broad representation of stakeholders.

#### Cybersecurity;

- The industry has sought to proactively address cybersecurity challenges. In 2015, the Automotive Information Sharing and Analysis Center (Auto-ISAC) was created to share information and collaboratively address cybersecurity threats. Proactive, industry-led efforts—in contrast to a top-down regulatory approach—will best ensure that industry meets cybersecurity challenges without impeding innovation unnecessarily. In seeking to protect consumers' security, policymakers must not tie the hands of innovators, which would inhibit or prohibit the best technology solutions to security challenges from emerging and continually evolving.
- NHTSA should be directed to update the 2016 Cybersecurity Best Practices to reflect changes in technology.

#### Privacy;

- The Federal Trade Commission (FTC) has primary jurisdiction over privacy issues, while NHTSA remains focused on safety. As NHTSA states on its website “generally, it is the [FTC] and not the U.S. Department of Transportation or NHTSA that is charged with protecting consumer privacy.”<sup>1</sup> NHTSA goes on to note that “[d]espite rapid changes in technology across numerous sectors, the FTC's overall approach to privacy has remained consistent” and signals the agency's intention to work closely with the FTC in addressing any consumer privacy implications of vehicle technologies.<sup>2</sup> We support NHTSA's continued

<sup>1</sup> See Automated Driving Systems: Frequently Asked Questions, NAT'L HIGHWAY TRAFFIC SAFETY ADMIN., <https://www.nhtsa.gov/manufacturers/automated-driving-systems>.

<sup>2</sup> *Id.*

commitment to defining the respective roles and responsibilities of the two agencies with respect to vehicle policy issues and agree with the allocation of roles that NHTSA and the FTC have settled upon. Ensuring that Federal agencies play complementary, as opposed to overlapping or conflicting, roles with respect to AV technology is important to developing a clear and consistent policy framework that fosters innovation.

Consumer Education;

- Consumer education is an essential element to ensuring the acceptance and success of self-driving vehicles. Coordinated efforts between the industry and DOT, like how the FAA has worked with UAS stakeholders on the Know Before You Fly Campaign, will be helpful in this effort.
- CTA is a founding member of Partners for Automated Vehicle Education (PAVE), and industry-led effort to educate consumers on both current and future vehicle technology.

Safety Evaluation Reports;

- CTA supports the use of Voluntary Safety Self-Assessments (VSSAs) as detailed in the Federal Automated Vehicle Policy 3.0.

Crash Data, including reporting requirements;

- The 5th edition of the Model Minimum Uniform Crash Criteria (MMUCC) includes automated vehicle crashes. Further, state and local governments are updating their data collection efforts to reflect MMUCC. Therefore, we do not see a need to address crash data in Federal legislation.

Resources for NHTSA;

- CTA does not advocate on government spending; therefore, we do not have a position on funding for NHTSA.

Disability Access;

- Access for individuals with disabilities remains a top priority for the industry. It is important to maintain flexibility for the manufacturer to address the needs of the consumer and to expedite the development of life-saving technology. The disability community should be included in any advisory groups related to this matter.
- States should ensure that licensure requirements for individuals with a disability are compliant with the ADA.

Maintaining DOT's existing authority over larger vehicles;

- CTA does not request any changes to DOT's existing authority over larger vehicles.

Non-AV safety requirements;

- CTA urges that AV legislation be solely focused on ADS-equipped vehicles defined as Levels 3 through 5 by SAE. In Levels 3 through 5, the ADS monitors the driving environment. In Levels 3 through 5, ADS performs the entire dynamic driving task while it is engaged. NHTSA's ADS guidance and VSSA elements are squarely applicable to Levels 3 through 5 only.

Global Competitiveness.

- Congress should emphasize the necessity of Federal legislation to remain competitive with other countries and maintain our leadership position in automotive innovation and safety.

CTA appreciates the opportunity to provide the committee with our priorities for legislation addressing self-driving and automated vehicle technology. We look forward to working with you to advance legislation enabling the development and use of vehicles that will make our roads safer.

Sincerely,

JAMIE BOONE,  
*Vice President, Government Affairs,*  
 Consumer Technology Association.

CC: Members of the Senate Committee on Commerce, Science, and Transportation

U.S. CHAMBER OF COMMERCE'S TECHNOLOGY ENGAGEMENT CENTER  
*Washington, DC, November 19, 2019*

Hon. ROGER WICKER,  
 Chairman,  
 Senate Committee on Commerce,  
 Science, and Transportation,  
 United States Senate,  
 Washington, DC.

Hon. MARIA CANTWELL,  
 Ranking Member,  
 Senate Committee on Commerce,  
 Science, and Transportation,  
 United States Senate  
 Washington, DC.

Dear Chairman Wicker and Ranking Member Cantwell:

The U.S. Chamber of Commerce's Technology Engagement Center (C\_TEC) respectfully submits the following statement for the record for the committee's hearing entitled, "Highly Automated Vehicles: Federal Perspectives on the Deployment of Safety Technology."

C\_TEC strongly supports the Committee's efforts to understand how to most effectively reduce the number of roadway fatalities and ensure the safety of America's transportation system. According to the National Highway Traffic Safety Administration, 36,540 Americans lost their lives in 2018 due to motor vehicle crashes, 94 percent of which are caused by human error.

To address this problem, C\_TEC believes that the safe deployment of automated vehicles would dramatically reduce the number of motor vehicle fatalities and make our roads safer. Moreover, the introduction of automated vehicles would empower millions of Americans currently unable to drive or otherwise limited in their mobility. In addition, automated vehicles would bring significant economic benefits for American workers and consumers. Automated vehicles are projected to add \$800 billion in cumulative economic benefits by 2050.

C\_TEC believes that Congress can take an important role in facilitating the safe development, testing, and deployment of this life-saving technology and earlier this year developed Automated Vehicle Policy Principles to guide our approach (attached). These principles include: ensure a safety first approach, preserve the existing delineation of regulatory roles, promote technology and stakeholder neutrality, advance safe automated vehicle development, testing, and deployment, and modernize Federal motor vehicle safety standards and regulations.

Last Congress, C\_TEC was supportive of the Committee's leadership on S. 1885, the "American Vision for Safer Transportation through Advancement of Revolutionary Technologies (AV START) Act," and we are encouraged by the current bipartisan, bipartisan process to develop automated vehicle legislation. In addition, we are appreciative of the leadership shown by the Administration and by Secretary of Transportation Elaine Chao to advance automated vehicles and maintain American leadership in this technology.

Automated vehicles has the potential to save thousands of lives every year, enhance mobility for millions of Americans, and spur economic growth. Thank you for including this statement into the record, and C\_TEC stands ready to work with the Committee and its members to safely advance automated vehicles.

Sincerely,

TIM DAY,  
*Senior Vice President,*  
 C\_TEC U.S. Chamber of Commerce.

cc: Members of the Committee on Commerce, Science, and Transportation

---

PARTNERS FOR AUTOMATED VEHICLE EDUCATION  
*November 19, 2019*

Hon. ROGER WICKER,  
 Chairman,  
 Senate Committee on Commerce,  
 Science, and Transportation,  
 Washington, DC.

Hon. MARIA CANTWELL,  
 Ranking Member  
 Senate Committee on Commerce,  
 Science, and Transportation,  
 Washington, DC.

Dear Senator Wicker and Senator Cantwell,

Thank you for convening today's hearing, "Highly Automated Vehicles: Federal Perspectives on the Deployment of Safety Technology." Public hearings with experts on this important technology are an important venue for raising the level of public knowledge about automated vehicles.



Partners for Automated Vehicle Education (PAVE) is a diverse coalition of safety, mobility and sustainability advocates and industry participants who are united by two beliefs: the belief that automated vehicles have substantial potential benefits, and the belief that we will not achieve these benefits without the understanding and trust of the public.

To help achieve these potential benefits, PAVE is embarked on a campaign to help raise the level of public understanding about AV technology and its potential. This week, PAVE has teamed with the National League of Cities and PAVE member NAVYA to offer demonstration rides in a NAVYA automated shuttle to attendees at NLC's City Summit in San Antonio, Texas. Demonstration events like this help expose more Americans to these new technologies and raise their level of knowledge and awareness.

PAVE does not advocate for specific public policies, legislation or regulation. But we recognize the potential of automated vehicles to help reduce the roughly 37,000 annual deaths on U.S. roads and to improve transportation accessibility and sustainability. PAVE is highly focused on creating a more informed public as well as helping to inform policymakers charged with crafting the policies related to automated vehicles that can unlock these benefits. We also recognize the need for public information on automated vehicles to be accurate and fact-based, to accurately portray the capabilities and limitations of advanced vehicle technologies, and to avoid misleading drivers by creating an inaccurate impression of those capabilities. This means drawing a clear line for consumers between driver assistance systems that aid drivers (as defined up to SAE Level 2 in the Level 0–5 scale) and higher levels of automation (SAE levels 3–5). PAVE's mission is to provide just that sort of hype-free information, so that whatever policies are established at the federal, state or local level, those policies are informed by the best information available.

We appreciate your continued focus on these important issues and stand ready to assist in any way we can to help raise the level of knowledge and understanding on automated vehicles.

Respectfully,

BRAD STERTZ  
PAVE Co-Chair  
Director of Government Affairs  
Audi USA

KELLY NANTEL  
PAVE Co-Chair  
Vice President of Communications and  
Advocacy  
National Safety Council

AURORA  
November 20, 2019

Chairman ROGER WICKER,  
Ranking Member MARIA CANTWELL,  
U.S. Senate Committee on Commerce, Science, and Transportation,  
Washington, DC.

Dear Chairman Wicker and Ranking Member Cantwell,

Aurora's mission is to deliver the benefits of self-driving technology safely, quickly, and broadly. We are building the Aurora Driver, a platform that combines hardware, software, and data services that allows vehicles to move people and goods safely through the world. When complete, the Aurora Driver will enable a transportation ecosystem, bringing together automakers, logistics services, mobility services, and fleet management providers to deliver the benefits of self driving technology broadly.

Safety is our first priority in developing the Aurora Driver.<sup>1</sup> Our primary motivation is reducing accidents, injuries, and fatalities. The status quo<sup>2</sup> is not acceptable and we are working to do something about it. We put safety top of mind with everything that we do at Aurora, from the people that we hire to our development and decision-making process.

In conjunction with the hearing on "Highly Automated Vehicles: Federal Perspectives on the Deployment of Safety Technology", we would like to offer a few perspectives. Aurora strongly believes that government and regulators are key partners to the safe and successful deployment of self-driving vehicle technology. There are several elements and examples of Aurora's approach to safety that are worth high-

<sup>1</sup><https://medium.com/aurora-blog/putting-safety-into-practice-auroras-safety-approach-5297de2d8276>

<sup>2</sup><https://www.nhtsa.gov/press-releases/roadway-fatalities-2018-fars>

lighting as the Committee considers this important topic. There are four pillars to our safety culture at Aurora: practice a culture of safety; develop the technology safely; establish safety metrics; and collaborate and educate. In fact, Aurora was the first company approved by the Pennsylvania Department of Transportation to test our technology on public roads in the state.

Aurora published a detailed Voluntary Safety Self-Assessment (VSSA) outlining our focus on safety including the importance of simulation in the development of the Aurora Driver, our driver safety protocols and training programs, and our grounding policy.<sup>3</sup> For example, all Aurora employees, from founders to engineers to vehicle operators and business analysts, are empowered to ground the fleet if they identify something they consider a safety risk. In addition, virtual testing is a critical component of how we develop and test our technology safely and efficiently. We resist the urge to put more and more cars on the road in an effort to ramp up on-road miles. Instead, we use on-road testing to validate our virtual tests. When we are on the road, we have two expert human vehicle operators in our cars at all times. They undergo an intensive six-week training program when they begin, and continue training each week.

We need to partner with the government to put regulations in place that keep citizens safe, while also encouraging rapid innovation. As an example, there is currently a patchwork of regulations governing how humans should drive—and they often vary from state to state. Self-driving technology can save even more lives if states and cities can come together and work with industry groups to agree on consistent standards and metrics. We have begun to work with regulators to brainstorm ways to bring the states and communities together to standardize current road rules.

Aurora has also engaged with the Committee on your efforts to develop Federal highly automated vehicle legislation. Your leadership is greatly appreciated and we look forward to continuing to work with you. As your Committee approaches legislation, we continue to encourage you to level the playing field for all developers of self-driving technology and ensure that innovative, job-creating companies like Aurora are not disadvantaged versus incumbents.

Aurora's primary concerns for any Federal legislation are to, first, ensure that the National Highway Traffic Safety Administration (NHTSA) retains its primary safety authority vis-à-vis the states and, second, expand the ability of all companies to take advantage of exemptions in the development of their self-driving systems. While these two issues are critical to the development of self-driving cars, there will be additional issue areas where Aurora can offer expertise and insight to the committees' future work on legislation addressing Level 3 automation and above. We look forward to continuing this conversation and reviewing language as your committee goes through the legislative process.

Thank you for the opportunity to provide feedback on the topic of safety in the development and deployment of self-driving vehicle technology.

Sincerely,

GERARDO INTERIANO,  
*Head of Government Relations.*

cc: Members of the U.S. Senate Committee on Commerce, Science, and Transportation

---

NATIONAL ASSOCIATION OF MANUFACTURERS  
*Washington, DC, November 20, 2019*

Hon. ROGER WICKER,  
Chairman,  
Committee on Commerce, Science, and  
Transportation,  
United States Senate,  
Washington, DC.

Hon. MARIA CANTWELL,  
Ranking Member,  
Committee on Commerce, Science, and  
Transportation,  
United States Senate,  
Washington, DC.

Dear Chairman Wicker and Ranking Member Cantwell:

The National Association of Manufacturers welcomes the Committee's attention to the topic of autonomous vehicles with the hearing entitled "Highly Automated Vehicles: Federal Perspectives on the Deployment of Safety Technology," and we appreciate the opportunity to share our perspective on this important issue.

---

<sup>3</sup><https://aurora.tech/vssa/index.html>

The NAM is the largest manufacturing association in the United States representing manufacturers in every industrial sector and in all 50 states. Manufacturing employs more than 12.8 million men and women, contributes nearly \$2.4 trillion to the U.S. economy annually, has the largest economic impact of any major sector and accounts for 64 percent of all private-sector research and development in the Nation.<sup>1</sup> The NAM is the powerful voice of the manufacturing community and the leading advocate for a policy agenda that helps manufacturers compete in the global economy and create jobs across the United States.

The NAM represents all parts of the passenger and commercial AV supply chain, including original equipment manufacturers, suppliers, and entities involved in the design, testing and manufacturing of ADS, as well as commercial vehicle and multimodal transportation manufacturers and suppliers. The NAM also represents manufacturers who rely on advanced transportation technology to better serve their customers and communities.

As automotive technologies continue to advance, manufacturers in the United States continue to take the lead in designing and making products that improve safety and enhance the driving experience. Manufacturers have been early innovators of the technologies and products found in Automated Driving Systems and are building on long-standing research, knowledge and success to advance the safe, timely and widespread deployment of autonomous vehicles.

The NAM believes vehicles equipped with well-tested and proven AV technologies will present a new opportunity to make our roadways safer. According to National Highway Traffic Safety Administration (NHTSA) data released last year, human error was the critical cause in 94 percent of vehicle crashes.<sup>2</sup> Safety continues to be a primary objective for manufacturers at every stage of the process to design, build, test, operate and deploy autonomous vehicles. Manufacturers appreciate that Congress and the Department of Transportation have recognized the safety improvement potential presented by AV technologies and the need to address barriers for innovation and adoption of these technologies to realize those safety benefits.

The NAM continues to call for ongoing collaboration between industry and government to develop a voluntary, evolving framework that fosters further innovation in autonomous vehicle technology by manufacturers in America. As the NAM's Building to Win infrastructure blueprint states:

This is an exciting time for automotive and truck manufacturers as well as suppliers, but to maintain a mantle of leadership, our Nation's elected officials and leaders must get safety regulations and the adoption of new technologies right . . . Also, a Federal regulatory approach that considers the industry a technology partner and allows for innovation will be instrumental to the further success of automated driving systems (ADS).<sup>3</sup>

The NAM supports the ongoing work by DOT to develop a framework to promote progress on AV deployment and has communicated that manufacturers hope to see further progress on broad regulatory changes in the attached comments. At the same time, we urge Congress to recognize that Federal legislation is needed to fully advance these objectives. The NAM appreciates this Committee's leadership in the ongoing bipartisan, bicameral process to develop AV legislation. As these efforts progress, DOT's AV 3.0 automation principles, which include prioritizing safety, a commitment to remaining technology neutral, modernizing regulations and promoting a consistent regulatory and operational environment, should guide Congress as it sets out AV policy.

Federal legislation is necessary to clarify the role of the Federal and state governments in the advancement of AV innovation. The NAM has long supported an approach in which the vehicle and roadway safety experts at DOT lead the policy development for furthering automated technology for all types of motor vehicles on our Nation's roadways. The growth of AV technology and the accompanying advancement of AV safety goals can best be accomplished through a government-stakeholder partnership that provides a clear Federal framework for the testing and deployment of AVs and flexibility for industry in the technical development and design of the technology. Federal policy should prevent a patchwork of conflicting state requirements that can create regulatory uncertainty and delay the deployment of AV technologies. Federal legislation can also modernize and speed the regulatory process, and it should advance a technology-neutral approach that promotes competition and aids innovation for manufacturers developing new products and future technologies.

<sup>1</sup> <https://www.nam.org/facts-about-manufacturing/>

<sup>2</sup> <https://crashstats.nhtsa.dot.gov/Api/Public/ViewPublication/812506>

<sup>3</sup> [https://www.nam.org/wp-content/uploads/2019/05/IIHR.BTW\\_2019.v08.pdf](https://www.nam.org/wp-content/uploads/2019/05/IIHR.BTW_2019.v08.pdf)

Transformational automotive technologies are advancing around the world, and the United States must create an environment that fosters safe and timely adoption of AV technologies to retain industry leadership and maintain global competitiveness. As this Committee develops legislation to support the future of transportation, we encourage the Committee to continue to engage with stakeholders to ensure that emerging solutions work for those creating, manufacturing and investing in AV technologies. The NAM appreciates the leadership of the Committee on AV policy and the opportunity to share our key priorities on this important issue.

Sincerely,

ROBYN BOERSTLING,  
*Vice President,*

Infrastructure, Innovation and Human Resources Policy.

Enclosures: 3

---

NATIONAL ASSOCIATION OF MANUFACTURERS  
*Washington, DC, December 3, 2018*

U.S. Department of Transportation  
1200 New Jersey Avenue, SE  
West Building, Room W12-140  
Washington, DC 20590-0001

RE: Preparing for the Future of Transportation: Automated Vehicles 3.0 (AV 3.0)  
(Docket No. DOT-OST-2018-0149)

On behalf of the 14,000 members of the National Association of Manufacturers (NAM), the largest manufacturing association in the United States representing manufacturers in every industrial sector and in all 50 states, the NAM submits these comments in response to the Department of Transportation's (DOT) request for comment on Preparing for the Future of Transportation: Automated Vehicles 3.0 (AV 3.0).

Manufacturing employs more than 12 million men and women, contributes over \$2 trillion to the U.S. economy annually, has the largest economic impact of any major sector and accounts for more than three-quarters of all private-sector research and development in the Nation. The NAM is the powerful voice of the manufacturing community and the leading advocate for a policy agenda that helps manufacturers compete in the global economy and create jobs across the United States.

Manufacturers are leading innovators, designing and producing products that improve the lives of customers and using technologies that transform manufacturing processes. Manufacturers were early innovators of the technologies and products in Automated Driving Systems (ADS) and are poised to continue to lead in the safe, timely and widespread deployment of autonomous vehicles (AVs). The NAM represents all parts of the AV supply chain, including original equipment manufacturers, suppliers, and entities involved in the design, testing and manufacturing of ADS, as well as commercial vehicle and multimodal transportation manufacturers and suppliers. The NAM also represents manufacturers who rely on advanced transportation technology to better serve their customers and communities. The NAM welcomes the opportunity to comment on DOT's updated approach to ADS in AV 3.0.

AV technology presents an opportunity to make our roadways safer. According to National Highway Traffic Safety Administration (NHTSA) data released this year, human error was the critical cause in 94 percent of vehicle crashes.<sup>1</sup> Safety continues to be a primary objective for manufacturers at every stage of the process to design, build, test, operate and deploy autonomous vehicles.

The NAM submitted comments on the Federal Automated Vehicle Policy (the "Policy") released in 2016 and Automated Driving Systems: A Vision for Safety (the "Guidance") in 2017. In both cases, we noted our appreciation for NHTSA's outreach to industry and highlighted the need for ongoing collaboration to develop a voluntary, evolving framework that fostered further innovation in autonomous vehicle technology by manufacturers in America. The NAM appreciates DOT's continued outreach to manufacturers and that AV 3.0 represents a continuation of the approach taken in the prior frameworks while also incorporating additional stakeholder feedback.

The NAM has consistently called for guidance that is voluntary and provides flexibility for manufacturers to continue to innovate in ADS. AV 3.0 builds upon the voluntary guidance provided in 2017. The NAM appreciates that DOT continues to em-

<sup>1</sup><https://crashstats.nhtsa.dot.gov/Api/Public/ViewPublication/812506>

phasize the voluntary nature of developers' safety self-assessments and supports the development of voluntary technical standards and approaches for AV deployment. AV 3.0 "reaffirms DOT's reliance on a self-certification approach, rather than type approval, as the way to balance and promote safety innovation." Manufacturers prioritize safety and are committed to taking steps to build consumer confidence in the safety of AV technology. At this point in time, advancing AV safety goals can be best accomplished through a government-stakeholder partnership that provides a clear Federal framework for the testing and deployment of AVs and flexibility for industry in the technical development and design of the technology.

The NAM welcomes DOT's multimodal approach to the deployment of ADS in AV 3.0. The updated framework incorporates commercial vehicles and considers the authorities of the surface transportation operating administrations within DOT with jurisdictions impacted by AV technology. The NAM agrees that the best way to achieve the Federal Motor Carrier Safety Administration's (FMCSA) goal of reducing crashes involving commercial vehicles is to create a regulatory environment that speeds the development of ADS in these systems. Manufacturers look forward to participating in the subsequent development of policy and regulations by FMCSA to promote the integration of ADS-equipped commercial motor vehicles.

The NAM supports the continued approach in AV 3.0 to the role for the Federal and state governments in the advancement of AV innovation, specifically the call for states and localities to avoid unnecessary and incompatible regulations that could create hurdles for AV technologies. The NAM has long supported an approach to AVs in which the vehicle and roadway safety experts at DOT lead the policy development for this innovative technology. The Federal Government's approach should modernize the regulatory process and prevent a patchwork of conflicting state requirements from unnecessarily interfering with the timely deployment of AVs. The NAM supports congressional action on legislation to achieve this goal. The House of Representatives passed the SELF DRIVE ACT (H.R. 3388), introduced by Representatives Bob Latta and Jan Schakowsky, in September 2017. The AV START Act (S. 1885), introduced by Senators John Thune and Gary Peters, remains pending in the Senate. These two pieces of legislation would speed the development of NHTSA safety regulations workable for AVs, provide a pathway for AV manufacturers to test the technology while regulations are updated and clarify the role of the Federal and state governments to prevent a potentially conflicting and costly regulatory environment.

This transformational automotive technology is advancing around the world, and the United States has an opportunity to boost its global competitiveness by creating an environment that fosters safe and timely adoption. The NAM remains committed to working with DOT and its key modal agencies to accomplish this shared goal.

Comments submitted electronically by:

STEPHANIE HALL,  
*Director of Innovation Policy,*  
National Association of Manufacturers.

---

NATIONAL ASSOCIATION OF MANUFACTURERS  
*Washington, DC, August 26, 2019*

Docket Management Facility  
U.S. Department of Transportation  
1200 New Jersey Avenue, SE  
West Building, Ground Floor, Room W-12-140  
Washington, DC 20590-0001

Re: Safe Integration of Automated Driving Systems-Equipped Commercial Motor Vehicles (Docket No. FMCSA-2018-0037)

On behalf of the 14,000 members of the National Association of Manufacturers, the largest manufacturing association in the United States representing manufacturers in every industrial sector and in all 50 states, the NAM submits these comments in response to the Federal Motor Carrier Safety Administration's advanced notice of proposed rulemaking regarding the safe integration of automated driving systems-equipped commercial motor vehicles on our Nation's roadways.

Manufacturing employs more than 12.8 million men and women, contributes \$2.38 trillion to the U.S. economy annually, has the largest economic multiplier of any major sector and accounts for more than three-quarters of private-sector research and development. The NAM is the powerful voice of the manufacturing community and the leading advocate for a policy agenda that helps manufacturers compete in the global economy and create jobs across the United States.

As automotive technologies continue to advance, manufacturers in the United States continue to take the lead in designing and making products that improve safety and enhance the driving experience. Manufacturers have been early innovators of the technologies and products found in Automated Driving Systems and are building on long-standing research, knowledge and success to advance the safe, timely and widespread deployment of autonomous vehicles.

The NAM represents all parts of the passenger and commercial vehicle AV supply chain, including original equipment manufacturers, suppliers, and entities involved in the design, testing and manufacturing of ADS, as well as multimodal transportation manufacturers and suppliers developing automated technologies to improve all types of freight movements. The NAM also represents manufacturers who rely on advanced transportation technology to better serve their customers and communities.

According to National Highway Traffic Safety Administration (NHTSA), human error remains the critical cause of 94 percent of vehicle crashes. As the NAM's Building to Win infrastructure blueprint states:

This is an exciting time for automotive and truck manufacturers as well as suppliers, but to maintain a mantle of leadership, our Nation's elected officials and leaders must get safety regulations and the adoption of new technologies right . . . Also, a federal regulatory approach that considers the industry a technology partner and allows for innovation will be instrumental to the further success of (ADS).<sup>1</sup>

The NAM believes commercial motor vehicles that will be equipped with well-tested and proven ADS will present a new opportunity to make our roadways safer. At every stage of the process, safety continues to be the primary objective for manufacturers that are designing, building, testing, operating and deploying autonomous vehicles. The NAM agrees with the Department of Transportation's AV 3.0 estimation that the best way to achieve the Federal Motor Carrier Safety Administration's (FMCSA) goal to enhance safety is to create a regulatory environment that encourages the safe acceleration and adoption of ADS in CMVs.

The NAM applauds the DOT and FMCSA for their flexible regulatory approach to AV technology as it applies to passenger and commercial motor vehicles because the evolving transportation landscape requires an ongoing modernization of regulatory policies. We encourage DOT to expand the process of reviewing antiquated policies to make the application of ADS consistent with other modes of transportation, such as rail. The NAM submitted comments in 2018 to "Preparing for the Future of Transportation: Automated Vehicles 3.0" (AV 3.0) and highlighted the need for ongoing collaboration with all transportation and manufacturing stakeholders to develop a voluntary, evolving framework that fostered further innovation in autonomous vehicle technology.

In addition to a focus on safety, FMCSA must advance a regulatory policy that allows for autonomous technology to deliver increasing gains in freight efficiency and mobility. Ongoing innovation requires continued flexibility and a Federal framework that is focused on long-term progress and prepared for ongoing technology evolutions that can rapidly change. In AV 3.0, FMCSA correctly decided to "no longer assume that the CMV driver is always a human or that a human is necessarily present onboard a commercial vehicle during its operation."

Manufacturers encourage FMCSA to further explain this future-forward approach in its Notice for Proposed Rulemaking and analyze future implications of that assumption regarding drivers so that manufacturers and suppliers can appropriately prepare products for the market.

Further, as technology advances specifically around deployment of more advanced AV systems, FMCSA will likely need to modify policies surrounding certifications and training for commercial drivers, new digital identification, hours of service or other factors outlined in the ANPRM. However, it is important that any modification to FMCSA's current regulations be technology neutral. FMCSA must avoid technology mandates that stifle innovation, limit competition or disrupt supply chains by picking winners and losers.

In support of interstate commerce, the Department of Transportation must continue to lead the development of safety-oriented policy to govern the continued introduction of AV technology. The FMCSA has a clear responsibility to regulate commercial motor vehicle safety and to assert Federal leadership in order to avoid regulatory uncertainty and prevent the deleterious impacts of a 50-state patchwork. The

<sup>1</sup>[https://www.nam.org/wp-content/uploads/2019/05/IIHR.BTW\\_2019.v08.pdf](https://www.nam.org/wp-content/uploads/2019/05/IIHR.BTW_2019.v08.pdf)

NAM strongly supports the pre-emptive authority that FMCSA reiterated in its AV 3.0 framework.

Transformational automotive technologies are advancing around the world, and the United States has an opportunity to lead and maintain global competitiveness by creating an environment that fosters safe and timely adoption of ADS in commercial motor vehicles. DOT and FMCSA should continue to lead the regulatory promulgation with the input of all necessary stakeholders to support the many benefits of AV technologies. The NAM appreciates FMCSA's consideration of these comments on behalf of manufacturers and remains committed to working with the FMCSA to accomplish this shared goal.

Comments Submitted by:

CATIE KAWCHAK,  
*Director, Infrastructure Policy,*  
 National Association of Manufacturers.

---

NATIONAL ASSOCIATION OF MANUFACTURERS  
*Washington, DC, August 27, 2019*

Docket Management Facility  
 U.S. Department of Transportation  
 1200 New Jersey Avenue, SE  
 West Building, Ground Floor, Room W12-140  
 Washington, DC 20590-0001

Re: Removing Regulatory Barriers for Vehicles With Automated Driving Systems  
 (Docket No. NHTSA-2019-0036)

On behalf of the 14,000 members of the National Association of Manufacturers (NAM), the largest manufacturing association in the United States representing manufacturers in every industrial sector and in all 50 states, the NAM submits these comments in response to the National Highway Traffic Safety Administration's advance notice of proposed rulemaking (ANPRM) on Removing Regulatory Barriers for Vehicles With Automated Driving Systems.

Manufacturing employs more than 12 million men and women, contributes over \$2 trillion to the U.S. economy annually, has the largest economic multiplier of any major sector and accounts for more than three-quarters of all private-sector research and development in the Nation. The NAM is the powerful voice of the manufacturing community and the leading advocate for a policy agenda that helps manufacturers compete in the global economy and create jobs across the United States.

As automotive technologies continue to advance, manufacturers in the United States continue to take the lead in designing and making products that improve safety and enhance the driving experience. Manufacturers have been early innovators of the technologies and products found in Automated Driving Systems and are building on long-standing research, knowledge and success to advance the safe, timely and widespread deployment of autonomous vehicles. The NAM represents all parts of the passenger and commercial AV supply chain, including original equipment manufacturers, suppliers, and entities involved in the design, testing and manufacturing of ADS, as well as commercial vehicle and multimodal transportation manufacturers and suppliers. The NAM also represents manufacturers who rely on advanced transportation technology to better serve their customers and communities.

The NAM believes vehicles equipped with well-tested and proven ADS will present a new opportunity to make our roadways safer. According to NHTSA data released last year, human error remains the critical cause of 94 percent of vehicle crashes.<sup>1</sup> At every stage of the process, safety continues to be a primary objective for manufacturers that are designing, building, testing, operating and deploying autonomous vehicles. Manufacturers appreciate that NHTSA recognizes the safety improvement potential presented by ADS technologies, and the need to address barriers for innovation and adoption of these technologies to realize those safety benefits.

The NAM welcomes the opportunity to comment on this ANPRM intended to remove regulatory barriers that would prevent the timely deployment of AVs. The NAM submitted comments in 2016 to the Federal Automated Vehicle Policy and in 2017 to Automated Driving Systems: A Vision for Safety, as well as in 2018 to the Department of Transportation's request for comment on Preparing for the Future of Transportation: Automated Vehicles 3.0 (AV 3.0). At each stage, the NAM con-

---

<sup>1</sup><https://crashstats.nhtsa.dot.gov/Api/Public/ViewPublication/812506>

tinues to call for ongoing collaboration between industry and government to develop a voluntary, evolving framework that fosters further innovation in autonomous vehicle technology by manufacturers in America. As the NAM's Building to Win infrastructure blueprint states:

This is an exciting time for automotive and truck manufacturers as well as suppliers, but to maintain a mantle of leadership, our Nation's elected officials and leaders must get safety regulations and the adoption of new technologies right . . . Also, a Federal regulatory approach that considers the industry a technology partner and allows for innovation will be instrumental to the further success of (ADS).<sup>1</sup>

The NAM has consistently called for guidance that is voluntary and provides flexibility for manufacturers to continue to innovate in ADS and reiterates here its support for that approach taken by DOT with AV 3.0. The NAM further supports the DOT's automation principles outlined in AV 3.0, which include prioritizing safety, committing to remaining technology neutral, modernizing regulations and promoting a consistent regulatory and operational environment. These principles should guide NHTSA's approach in this ANPRM to addressing compliance verification challenges that exist for crash avoidance standards contained in the Federal Motor Vehicle Safety Standards specific to the unique questions presented by ADS technologies.

The NAM supports an approach to solving compliance verification challenges with AVs that provides manufacturers with maximum flexibility to adapt technology and innovate in a quickly evolving and competitive area. In this ANPRM, NHTSA provides six possible approaches to revising crash avoidance test procedures, specifically for ADS vehicles that lack manual controls. Manufacturers support an approach that would permit these various safety testing procedures, or additional new procedures if a more suitable alternative emerges. Keeping the door open to multiple testing procedures both promotes competition and aids innovation for manufacturers developing new products and future technologies in AVs. The growth of AV technology and the accompanying advancement of AV safety goals can best be accomplished through a government-stakeholder partnership that provides a clear Federal framework for the testing and deployment of AVs and flexibility for industry in the technical development and design of the technology.

Transformational automotive technologies are advancing around the world, and the United States has an opportunity to lead and maintain global competitiveness by creating an environment that fosters safe and timely adoption of ADS technologies. DOT, NHTSA and the Department's key modal agencies should continue to consider broad regulatory changes necessary to foster the growth of AVs, working with stakeholders to ensure that emerging solutions work for those creating, manufacturing and investing in AV technologies. The NAM remains committed to working with DOT and NHTSA to accomplish these shared goals.

Comments submitted electronically by:

STEPHANIE HALL,  
*Director of Innovation Policy,*  
National Association of Manufacturers.

NURO  
MOUNTAIN VIEW, CA, NOVEMBER 20, 2019

Chairman Wicker and Ranking Member Cantwell  
Senate Committee on Commerce, Science, and Transportation

Dear Chairman Wicker and Ranking Member Cantwell:

Thank you for your leadership in holding today's important hearing on the development and introduction into society of autonomous vehicle technology. We respectfully submit these comments on the life-saving benefits of autonomous vehicles versus traditional automobiles, and how they can expand the approach to road safety implemented by the National Highway Traffic Safety Administration over the past several decades.

Nuro has built a new class of vehicle from the ground up: lightweight, passengerless delivery vehicles, originally engineered and manufactured to be operated autonomously rather than retrofitted. Nuro's vehicles never get distracted or impaired, have complete 360-degree vision, and are programmed to obey the rules of the road consistently. They offer a significant opportunity to address the more than 35,000

<sup>1</sup>[https://www.nam.org/wp-content/uploads/2019/05/IIHR.BTW\\_2019.v08.pdf](https://www.nam.org/wp-content/uploads/2019/05/IIHR.BTW_2019.v08.pdf)



fatalities that are now occurring yearly on our roads. Fully passengerless vehicles like Nuro's present an untapped opportunity: a chance to rethink our use of the car itself.

**The best way to improve American road safety is to help people to stay off the roads.**

Over the past half-century, automotive safety innovation has focused overwhelmingly on occupant protection, reducing the occupants' risk of injury or death in a collision. What has escaped adequate consideration is that the safest protection for people is not an airbag or seatbelt. With 43 percent of all car trips dedicated to performing shopping or other errands, nearly half of all trips we take can be replaced by an autonomous delivery vehicle that brings items to our homes, while we remain safely off the roads. *Imagine the safety impact of eliminating occupants from nearly half of all vehicle trips.*

**Passengerless vehicles focus on protecting people outside the vehicle, not what's inside.**

Without the need for front seats or equipment to protect a driver or passengers, dedicated autonomous delivery vehicles can be narrower and lighter, taking up less space on the road and more nimbly avoiding pedestrians and bicyclists. With no one inside to protect, the vehicle can self-sacrifice to avoid a collision, prioritizing human life outside the vehicle at all costs. The vehicle can even be specifically designed with a crumple zone to mitigate the impact of crashing into another road user. The benefits also extend to driving behavior. With no one in the vehicle to get impatient or uncomfortable, Nuro's vehicle can choose conservative routes and driving styles, or brake suddenly in an emergency.

There is an urgent need for increased focus on pedestrian safety. In 2018, there were 6,283 pedestrian fatalities in the United States, a 3 percent increase from 2017, and the highest national level since 1990. At the same time, SUVs and light trucks are an increasing share of American vehicles, accounting for 69 percent of new U.S. vehicle sales in 2018. These vehicles are 2-3 times more likely to kill pedestrians in a collision than a passenger car. *Small, lightweight delivery vehicles can replace many trips by SUVs, light trucks, and passenger cars with a vehicle optimized for pedestrian protection.*

**Federal regulatory action is urgently needed to save American lives.**

Today's vehicle safety standards were developed decades prior to the emergence of autonomous technology. They are imbued with the presumption that cars will always have drivers, passengers, seats, airbags, brake pedals, and side mirrors. That presumption has now been outmoded. We respectfully submit that our Federal government should move quickly to bring Federal motor vehicle safety standards into the modern age. The opportunity to save lives is tremendous, and the timing is critical.

The autonomous vehicle legislation that your Committee has been working towards would improve public trust in this new technology, create a clear regulatory framework, and promote a high standard of safety across the industry. Nuro supports legislation that would help the National Highway Traffic Safety Administration move expeditiously to set standards that ensure autonomous vehicles operate safely, while also removing regulatory barriers that provide no safety benefit and impede the deployment of safety innovations like passengerless vehicles.

\* \* \*

Thank you for holding this important hearing. If you would like to discuss these matters further, please contact Matthew Lipka at [mlipka@nuro.ai](mailto:mlipka@nuro.ai) or 609-731-3896. Sincerely,

DAVID ESTRADA,  
Chief Legal and Policy Officer,  
Nuro.

SECURING AMERICA'S FUTURE ENERGY  
*Washington, DC, November 20, 2019*

Hon. ROGER WICKER,  
 Chairman, Senate Commerce, Science,  
 and Transportation Committee,  
 Washington, DC.

Hon. MARIA CANTWELL,  
 Ranking Member, Senate Commerce,  
 Science, and Transportation  
 Committee,  
 Washington, DC.

Chairman Wicker and Ranking Member Cantwell:

Thank you for holding today's hearing, "Highly Automated Vehicles: Federal Perspectives on the Deployment of Safety Technology," to examine the Federal government's role in overseeing the safe development of automated vehicle technologies and their significant social and economic benefits. Securing America's Future Energy (SAFE) appreciates the opportunity to submit this letter for the hearing record.

SAFE is a nonpartisan, nonprofit organization committed to reducing U.S. oil dependence to improve

American economic and national security. In 2006, SAFE formed the Energy Security Leadership Council (ESLC), a nonpartisan group of business and former military leaders in support of long-term policy toward this goal. The ESLC is co-chaired by Frederick W. Smith, Chairman and CEO of FedEx, and General James T. Conway, 34th Commandant of the U.S. Marine Corps (Ret.).

SAFE believes that automated vehicle (AV) technology presents a significant opportunity to accelerate the market-based adoption of electric vehicles and reduce oil consumption, while also delivering many other public benefits including increased traffic safety and accessibility. Accordingly, we are supportive of policies that will support the safe and expeditious deployment of AVs and maximize their tremendous social and economic benefits.

Significant technological progress has been made in the development and testing of AVs in recent years, leading to early-stage deployments throughout the United States. Recently, some companies have begun to operate AVs in commercial services on public roads without a safety driver.<sup>1</sup> As an executive from another AV company later remarked, "We now live in a post-driverless world."<sup>2</sup>

In sharp contrast, Federal policy has struggled to keep pace with the rapid development of AV technology. The existing regulatory framework for motor vehicles was written with human-driven vehicles in mind, resulting in unforeseen barriers to AVs. The Federal government does not yet have a unified framework for AV safety, resulting in a lack of regulatory certainty for developers.

Congress has a significant role to play in ensuring that AV technology realizes its full potential to make transportation safer, more efficient, and accessible to all Americans. This begins with creating a Federal regulatory framework to guide the safe testing and deployment of AV technology nationwide, while also maximizing their eventual benefits. To this end, we thank the Committee for its leadership on AV START (S. 1885) in the 115th Congress.

While AV START ultimately was not enacted before the end of the last Congress, the need for AV legislation remains as urgent as ever: The status quo on our roadways has not changed. According to the National Safety Council, nearly 40,000 Americans lost their lives in traffic collisions for the third straight year in 2018.<sup>3</sup> Traffic congestion causes Americans to waste a total of 3.3 billion gallons of fuel—plus an average loss of 54 hours per commuter due to delays—every year.<sup>4</sup> Furthermore, six million Americans with a disability have difficulty accessing the transportation they need.<sup>5</sup>

SAFE applauds this Committee and the House Energy & Commerce Committee for launching a joint bipartisan effort to advance AV legislation in this Congress. At a high level, SAFE urges you to consider prioritizing the following three goals in drafting AV legislation:

- 1) Accelerate progress towards regulatory standards that assure the safety of AVs and eliminate barriers to innovative AV designs.

<sup>1</sup> <https://techcrunch.com/2019/11/01/hailing-a-driverless-ride-in-a-waymo/>

<sup>2</sup> [https://news.voyage.auto/we-now-live-in-a-driverless-world-cb07a01159c0#\\_ga=2.55017067.1948161981.1574102920-743940195.1521039822](https://news.voyage.auto/we-now-live-in-a-driverless-world-cb07a01159c0#_ga=2.55017067.1948161981.1574102920-743940195.1521039822)

<sup>3</sup> <https://www.nsc.org/road-safety/safety-topics/fatality-estimates>

<sup>4</sup> <https://tti.tamu.edu/news/new-study-underscores-economy-traffic-jam-link/>

<sup>5</sup> [http://secureenergy.org/wp-content/uploads/2017/01/Self-Driving-Cars-The-Impact-on-People-with-Disabilities\\_FINAL.pdf](http://secureenergy.org/wp-content/uploads/2017/01/Self-Driving-Cars-The-Impact-on-People-with-Disabilities_FINAL.pdf)

- 2) Establish an interim, Federal regulatory framework that can improve the governance of AVs until a long-term framework is put in place; this interim framework is critical, as it would govern AVs as they ramp up commercial operation.
- 3) Advance the societal benefits of AVs to increase transportation access for people with disabilities, wounded veterans, and disadvantaged communities.

At the request of the Committees, SAFE provided detailed policy recommendations for AV legislation in a letter submitted on August 22, which has also been made available on our website.<sup>6</sup>

Thank you again for your attention to the issue of Federal AV regulation and your consideration of the tremendous potential of this technology. We look forward to working with you and your colleagues to advance policies that will allow the U.S. transportation sector to thrive in the decades to come.

Thank you,

ROBBIE DIAMOND,  
*President and CEO,*  
Securing America's Future Energy.

UBER  
*November 20, 2019*

Dear Chairman Wicker & Ranking Member Cantwell,

In advance of today's hearing, Uber appreciates the opportunity to offer our views on legislation that will promote the safe development and deployment of self-driving vehicles, and to update the committee on the progress we have made on safety over the last twenty months. We appreciate the continued leadership of the Senate Commerce Committee on these important matters.

Developing self-driving technology is one of the biggest technical challenges of our time. If successful, these vehicles have the potential to make our roads safer and transportation more affordable for everyone.

We believe that safe development of safe self-driving technology can be further enabled by strong, evidence-based legislative and regulatory frameworks that build trust and confidence in the technology that developers are building. That's why Uber supports Congress advancing legislation to address those issues which are necessary for the development and commercialization of automated vehicles (AVs) featuring high degrees of automation. We believe that such legislation should have three essential components: (1) a framework to ensure that the National Highway Traffic Safety Administration (NHTSA) fulfills its responsibility to modernize safety design standards for AVs; (2) preemption that respects the traditional division between state and Federal authorities, and ensures nationwide uniformity in the approach to regulating AV design; and (3) exemptions for safe testing and deployment.

A bill which addresses the issues identified above will not create a permanent regulatory structure or diminish any existing tools available to regulators. Rather, any legislation will serve to create regulatory clarity for the developers of self-driving vehicles during the interim period when NHTSA has not yet modernized the Federal Motor Vehicle Safety Standards (FMVSS) to accommodate self-driving vehicles or related equipment. Such legislation will not diminish NHTSA's existing authorities to remove unsafe vehicles from the road, to promulgate regulations related to the design of autonomous vehicle equipment, or to regulate across an array of safety design issues.

We understand the legitimate concerns and questions about the safety of testing developmental self-driving vehicles on public roads. Uber Advanced Technologies Group (ATG) remains deeply regretful for March 2018 crash in which an Uber ATG test vehicle, that was under human supervision, struck and killed a pedestrian in Tempe, Arizona. Since this tragic crash, Uber has worked closely with the National Transportation Safety Board, The National Highway Traffic Safety Administration, and local officials throughout their respective investigations to fully understand the facts surrounding this tragic event. We are committed to continuous improvements and have used the facts from these investigations and other sources to enhance our self-driving program and to sharing our learnings on safety with the broader industry. Please refer below to an overview of key changes we have implemented since March 2018, including hyperlinks to public resources and page number references to our *Voluntary Safety Self-Assessment* (VSSA).

<sup>6</sup><http://secureenergy.org/press/safe-calls-on-congress-to-prioritize-self-driving-legislation/>

### Operational Changes

- Revised Operator Roles—Raised technical competency required, added Commercial Driver’s License-level medical fitness requirements, and increased involvement in development process, targeting roughly half of working time out of the vehicle (VSSA, pages 36–37, 41–44, 55–56).
- Enhanced Operator Training—Increased training on defensive driving, distracted driving, fatigue, system capabilities and failure modes, and policies (*blog post*) (VSSA, pages 41–44).
- Revised In-Vehicle Staffing—Reverted to two Mission Specialists in-vehicle for all testing and reduced hours of service limit to four hours behind the wheel in a given workday and two hours without taking a break or switching positions (VSSA, page 36, 55–56).
- Driver Monitoring System—Added a camera system which detects a distracted operator, sounds an audible alert in the cabin, and immediately sends a notification to a remote monitoring team for review and action (VSSA, page 56).
- Public Safety Officials & First Responders’ Guide—Published a tool for trained public safety officials that may interact with Uber ATG’s developmental self-driving vehicles (*blog post, guide, pocket guide*).

### Technical Changes

- Software Improvements—Implemented modifications to reduce system latency, improve detection/tracking of pedestrians and cyclists, and drive more defensively.
- Automated Emergency Braking—Implemented modifications to Volvo’s emergency braking system to enable simultaneous operation with our self-driving technology.
- Operator Interface—Revised touchscreen software to minimize distraction and introduced excess speed warning feature during manual driving (VSSA, pages 55–58).
- Simulation and Track Testing—Formalized and improved the process by which on-road testing is requested and approved, in order to increase the accountability and traceability of every mile we drive (VSSA, pages 46–50).

### Organizational Changes

- Operational Safety—Created an Operational Safety team within the independent System Safety team, with responsibilities including Mission Specialist training.
- Systems Engineering—Established a new, separate Systems Engineering and Testing team responsible for the adoption of a rigorous systems engineering approach, including new practices for change management and quality management.
- Safety Concern Reporting—Revamped an anonymous reporting system with non-retaliatory protection as part of our reinvestment in Safety Culture (VSSA, page 53).
- Voluntary Safety Self-Assessment—Published a detailed VSSA in accordance with guidance from the U.S. National Highway Traffic Safety Administration (*blog post, report*)
- Safety Case Framework—Open-sourced the framework for our safety case, an argument that, when coupled with articles of evidence, convinces key stakeholders that the risk of harm from the system has been reduced to an acceptable level (*blog post, framework*)
- Self-Driving Safety and Responsibility Advisory Board—Established an independent panel of safety experts charged with reviewing and suggesting changes to Uber ATG’s self-driving enterprise (*blog post*)

While we are proud of our progress, we will never lose sight of what brought us here or our responsibility to continue raising the bar on safety. Over the last 20 months, we have provided the NTSB with complete access to information about our technology and the developments we have made since the crash. Uber will now carefully review the NTSB’s findings and recommendations, with an eye towards continuing to improve and enhance our safety program and overall safety culture.

Sincerely,

DANIELLE BURR,  
Head of Federal Affairs.

CC: Members of the Senate Committee on Commerce, Science, and Transportation

PREPARED STATEMENT OF CATHERINE CHASE, PRESIDENT,  
ADVOCATES FOR HIGHWAY AND AUTO SAFETY

### Introduction

Advocates for Highway and Auto Safety (Advocates) is a coalition of public health, safety, and consumer organizations, insurers and insurance agents that promotes highway and auto safety through the adoption of Federal and state laws, policies and regulations. Advocates is unique both in its board composition and its mission of advancing safer vehicles, safer motorists and road users, and safer infrastructure.

In 2018, nearly 37,000 people were killed in motor vehicle crashes.<sup>1</sup> Moreover, crashes impose a financial toll of over \$800 billion in total costs to society and \$242 billion in direct economic costs, equivalent to a “crash tax” of \$784 on every American. This carnage and expense is unacceptable.

### Available Commonsense and Cost-Effective Solutions

Every day on average, over 100 people are killed and nearly 7,500 people are injured in motor vehicle crashes. While far too many lives are lost and people are injured on our Nation’s roads each year, proven solutions are currently available that can prevent or mitigate these senseless tragedies. The National Highway Traffic Safety Administration (NHTSA) currently values each life lost in a crash at \$9.6 million. Each one of these preventable losses not only irreparably harms families and communities, but they also impose significant costs on society that can be avoided. While we are optimistic that in the future autonomous vehicles (AVs) may bring about meaningful and lasting reductions in motor vehicle crashes, that potential remains far from a near-term reality.

Therefore, it is essential that advanced vehicle technologies, also known as advanced driver-assistance systems (ADAS), which prevent and lessen the severity of crashes be required as standard equipment on all new vehicles. In fact, the National Transportation Safety Board (NTSB) has included increasing implementation of collision avoidance technologies in its Most Wanted Lists of Transportation Safety Improvements since 2016.<sup>2</sup>

Currently available collision avoidance systems include automatic emergency braking (AEB), lane departure warning (LDW), blind spot detection (BSD), rear AEB and rear cross-traffic alert.

The Insurance Institute for Highway Safety (IIHS) has found that:

- AEB can decrease front-to-rear crashes with injuries by 56 percent;
- LDW can reduce single-vehicle, sideswipe and head-on injury crashes by over 20 percent;
- BSD can diminish injury crashes from lane change by nearly 25 percent;
- Rear AEB can reduce backing crashes by 78 percent when combined with rear-view camera and parking sensors; and,
- Rear cross-traffic alert can reduce backing crashes by 22 percent.<sup>3</sup>

However, these crash avoidance safety systems are often sold as part of an additional, expensive trim package along with other non-safety features, or included only in high end models or vehicles. Moreover, there are currently no minimum performance standards to ensure they perform as expected. Additionally, the IIHS has found that while nighttime visibility is essential for safety, few vehicles are equipped with headlights that perform well.<sup>4</sup> The Federal Motor Vehicle Safety Standard (FMVSS) 108 should be upgraded to improve headlight performance.

We urge Congress to require that advanced technologies that have proven to be effective at preventing and mitigating crashes be standard equipment with minimum performance standards. The Protecting Roadside First Responders Act (S. 2700/H.R. 4871) directs the U.S. Department of Transportation (DOT) to require certain crash avoidance technologies that meet a minimum performance requirement in all new cars. We urge the Committee to advance this legislation with urgency. In a similar vein, new trucks and buses should be required to have proven safety technologies including AEB and speed limiters. Therefore, Congress should swiftly enact the Safe Roads Act of 2019 (H.R. 3773), the School Bus Safety Act of 2019 (S.2278/H.R. 3959) and the Cullum Owings Large Truck Safe Operating Speed

<sup>1</sup> Statistics are from the U.S. Department of Transportation unless otherwise noted.

<sup>2</sup> NTSB Most Wanted List Archives, [https://nhtsa.gov/safety/mwl/Pages/mwl\\_archive.aspx](https://nhtsa.gov/safety/mwl/Pages/mwl_archive.aspx)

<sup>3</sup> IIHS, Real world benefits of crash avoidance technologies, available at: <https://www.iihs.org/media/259e5bbdf859-42a7-bd54-38887a2d3ef/e9boUQ/Topics/ADVANCED%20DRIVER%20ASSISTANCE/IIHS-real-worldCA-benefits.pdf>

<sup>4</sup> IIHS, Headlights improve, but base models leave drivers in the dark (Nov. 29, 2018).

Act of 2019 (S. 2033). On the path to AVs, requiring minimum performance standards for these foundational technologies will ensure the safety of motorists in vehicles and all roads users sharing the driving environment with them, while also building consumer confidence in the capabilities of these technologies.

### **Autonomous Vehicles are Not Ready for Public Roads, Public Sale or Public Safety**

Autonomous vehicles (AVs), also known as driverless cars, are being developed and tested on public roads without sufficient safeguards to protect both those within the AVs and everyone sharing the roadways with them, and without express consent. Advocates is very concerned that an artificial rush to pass legislation, fueled by AV manufacturers wanting to rush their product to market and recoup their investments, could significantly undermine safety as well as public acceptance and ultimate success of these vehicles. Numerous public opinion polls show a high skepticism and fear about the technology, and for good reason. (*See Attachment.*)

At least six crashes resulting in four fatalities have occurred in the U.S. involving cars equipped with autonomous technology that are being investigated by the NTSB. The outcomes of these investigations will further identify safety deficiencies, determine contributing causes, and recommend government and industry actions to prevent future deadly incidents. We urge Congress to allow the critical information from these investigations, conducted by our Nation's preeminent crash investigators, to be released before taking action so as to help guide policy.

Just yesterday, the NTSB held a meeting to consider the probable cause of the tragic crash that occurred on March 18, 2018, in Tempe, Arizona, in which Elaine Herzberg was killed by an Uber test vehicle equipped with self-driving features. Several weeks ago, the NTSB opened the docket into this crash and a review of the materials shed light on the following alarming and disturbing details:

- The Uber test vehicle (Volvo XC90) was equipped with an AEB system as well as a function for detecting driver alertness. These systems were disabled when the vehicle automated driving functions were being tested. Given the specifications of these features, in simulations the Volvo would have avoided the collision in 17 out of 20 different scenarios and reduced the impact speed to less than ten miles per hour (mph) in the other three.
- The test "driver" is relied on to intervene and take action if the automated system exhibits erratic or unsafe behavior; however, the system was not designed to alert the driver to hazards in the path of travel. The automated system identified the pedestrian as a hazard in the lane 1.2 second before collision. The system was designed to then wait one second before taking any action. At 0.2 seconds before collision, the system provided an auditory signal that a controlled slowdown will be initiated. The "driver" (the fallback for this system) did not initiate a steering maneuver until 0.02 seconds before collision and did not start braking until after the impact. Uber had removed the second co-pilot from the testing protocol in the fall of 2017.
- The crash occurred in the evening, free of any inclement weather conditions, on an urban road with a speed limit of 45 mph. These conditions fell within the operational design domain (ODD) of the automated system. However, the system was not designed to account for jaywalking pedestrians despite the fact that a large portion of pedestrian crashes happen on urban roads, at night, and at midblock locations.

Some proponents of advancing the deployment of AVs contend the U.S. is falling behind other nations. However, this fear-inducing claim is misleading as other countries are taking a more deliberate, careful and cautious approach. For example, Germany requires a human to be behind the wheel of a driverless car in order to take back control and has other important elements including requirements for vehicle data recording. In the United Kingdom, testing has largely been limited to a handful of cities, and the government has published a detailed code of practice for testing AVs, but not applying to vehicles for sale. In Asia, Japan has allowed on-road testing with a driver behind the wheel and is currently working on regulatory and legal schemes for controlling the commercial introduction of AVs, but even so has not begun to address the highest levels of automation. Similarly, South Korea has plans to test these vehicles but has generally limited testing to 200 miles of public roads or to test tracks.

Furthermore, numerous industry executives and technical experts have stated that the technology is not ready and may not be for years ahead. This June, Gill Pratt, Director of the Toyota Research Institute said, "None of us have any idea

when full self-driving will happen,”<sup>5</sup> Bryan Salesky, CEO of Argo AI, said in July, “Level 5 as it’s defined by the SAE levels is a car that can operate anywhere—no geographic limitation. We’re of the belief, because we’re realistic, that Level 5 is going to be a very long time before it’s possible. I’m not saying that Level 5 isn’t possible but it is something that is way in the future.”<sup>6</sup> John Krafcik, CEO of Waymo, said late last year, “This is a very long journey. It’s a very challenging technology and we’re going to take our time. Truly every step matters.”<sup>7</sup> The disconnect between the readiness of the technology and the artificial urgency to pass legislation to allow for widespread deployment is alarming and the perceived need to expedite enactment of AV legislation, especially absent rulemaking requirements, is misguided.

### **Boeing 737 MAX Crashes—Lessons Learned and Applicability to AVs**

The recent crashes involving the Boeing 737 MAX airplane tragically highlight the catastrophic results that can occur when automated technology potentially malfunctions and is not subject to thorough oversight. Reports indicate that many aspects of the plane’s certification were delegated to Boeing. In fact, the Federal Aviation Administration (FAA) never fully evaluated the flawed automated system. The behavior of the planes in both crashes prior to the impact focused suspicion on the automated system known as the Maneuvering Characteristic Augmentation System (MCAS). The pilots, who were trained not in MCAS but were following Boeing’s instructions, attempted to shut off and override the MCAS system when it was activating erroneously. However, they were unable to regain control of the aircraft. News reports indicate that the pilots may have had as little as 40 seconds to recover control of the planes in such instances. Had a thorough evaluation of this system been undertaken, its flaws may have been detected and corrected, preventing two needless tragedies and the loss of hundreds of innocent lives.

Subsequent to the certification of the MAX airplane, at the direction of Congress, the FAA has alarmingly been given even less responsibility for the oversight of new technologies and equipment placed in planes.<sup>8</sup> This change in policy was deeply concerning to regulators at the FAA who noted such a change in policy would “not be in the best interest of safety.”<sup>9</sup> Moreover, FAA inspectors warned that doing so would turn the FAA into a “rubber stamp.”<sup>10</sup> Yet, instead of ensuring proper government oversight, Congress created an advisory committee that has since become dominated by industry resulting in a Federal agency being deferential to the industry it is tasked with regulating.<sup>11</sup>

Upon reviewing aspects of the crashes involving the MAX, comparisons to the early stages of AV development should give all lawmakers and regulators serious pause. Safety systems that could have assisted the pilots were not required as standard equipment but were offered as an option at an additional cost, similar to what is currently occurring with crash avoidance technology for vehicles. Pilots receive extensive training on how to properly fly a commercial airplane including how to utilize complex operational systems. In sharp contrast, there are no Federal training requirements for individuals testing or operating automated vehicle technology or for the consumers who purchase these vehicles and are using them on public roads. News reports indicate that the pilots may have had as little as 40 seconds to address a malfunction with the MCAS system and recover control of the plane, and were unable to do so. In AVs where drivers are expected to monitor their operation or serve as fall back operators, drivers could be faced with even shorter time periods to respond before a crash occurs. We urge this Committee to heed these important observations as it considers proper safeguards of AVs for testing and public sale.

### **Safeguards Necessary to Protect Public Safety**

Legislation to allow for the successful development and deployment of AVs must advance a public safety agenda and not just an economic agenda. Both goals are compatible and achievable. Any bipartisan, bicameral bill must ensure that the U.S. DOT conducts thorough oversight, establishes a regulatory structure that sets minimum safety performance standards and requires industry accountability before driverless cars are available in the marketplace and sold to the public. It is vital

<sup>5</sup> Lawrence Ulrich, *Driverless Still a Long Way From Humanless*, N.Y. Times (Jun. 20, 2019).

<sup>6</sup> Level 5 possible but “way in the future”, says VW-Ford AV boss, *Motoring* (Jun. 29, 2019).

<sup>7</sup> WSJ Tech D. Live Conference (Nov. 13, 2018).

<sup>8</sup> Natalie Kitroeff and David Gelles, *Before Crashes, Boeing Pushed To Undercut F.A.A. Oversight*, N.Y. Times (Oct. 27, 2019).

<sup>9</sup> *Id.*

<sup>10</sup> *Id.*

<sup>11</sup> *Id.*

that Congress adequately addresses the broad range of impacts on safety, mobility and infrastructure rather than rush enactment of a flawed bill that jeopardizes public safety and consumer confidence.

On October 28, 2019, staff of the Senate Commerce, Science, and Transportation Committee and

House Energy and Commerce Committee released three draft sections of potential AV legislation. Despite numerous meetings, group letters and written responses from our organization and others to Committee staff regarding requests about safety priorities, recommended provisions and crucial objections, these three sections do not address our concerns. We vehemently oppose the use of these three sections as fundamental components of our Nation's first AV law. Moreover, we were prevented from providing a comprehensive analysis as we were not given access to the totality of the potential AV legislation. For the purposes of submitting feedback to comply with the Committees staffs' request, we wrote a memo outlining our concerns, red-lined the sections accordingly, and provided proactive language that must be included in any AV bill. Our high level concerns follow.

*New Rulemakings to set Performance Standards are Essential.* Legislation should include requirements for DOT to issue minimum performance standards by a date certain before AVs are available for sale in the marketplace. Congress has already established this precedent with other lifesaving and cost-beneficial laws resulting in airbags, tire pressure monitoring, rollover and ejection prevention, and recently, rearview cameras. Issues include:

- *Human-Machine-Interface (HMI) for Driver Engagement:* Research demonstrates that even for a driver who is alert and performing the dynamic driving task, a delay in reaction time occurs between observing a safety problem, reacting and taking needed action. For a driver who is disengaged from the driving task during autonomous operation of a vehicle (*i.e.*, sleeping, texting, watching a movie), that delay will be longer because the driver must first be alerted to re-engage, understand and process the situation, and then take control of the vehicle before taking appropriate action. According to an article published by Dr. M.L. Cummings and Jason Ryan entitled *Who Is in Charge? The Promises and Pitfalls of Driverless Cars*, “[d]rivers in an autonomous or highly automated car were less attentive to the car while the automation was active, were more prone to distractions, especially to using cellular phones, and were slower to recognize critical issues and to react to emergency situations, for example, by braking.”<sup>12</sup> The failure of the automated driving system to keep the driver engaged in the driving task was identified as a problem by the NTSB in its investigation of the 2016 fatal crash in Florida involving a Tesla Model S. Furthermore, IIHS highlighted this major safety problem in their August 7, 2018 Status Report: “Experimental studies have shown that drivers can lose track of what automated systems are doing, fail to notice when something goes wrong and have trouble retaking control.”
- *Cybersecurity Standard:* AVs must be subject to cybersecurity requirements to prevent against hacking. See below section on cybersecurity for more detail on this position.
- *Electronics Safety Standard:* AVs must be subject to minimum performance requirements for the vehicle electronics that power and operate safety and autonomous driving systems. Electronic glitches are commonplace and relatively harmless in instances of computer or cell phone crashes. However, if an AV fails to operate properly on public roads, the outcomes could be catastrophic and result in mass casualties. Interference from entertainment functions and non-safety systems can affect the electronics that power critical safety systems if they share the same wiring and circuits. For example, in one reported instance a vehicle model lost power to its dashboard lights when an MP3 player was plugged in.<sup>13</sup>
- *“Vision Test” for AVs:* Driverless cars must be subject to a “vision test” to guarantee an AV will properly detect and respond to other vehicles, pedestrians,

<sup>12</sup>Cummings, M.L., & J.C Ryan, “Who Is in Charge? Promises and Pitfalls of Driverless Cars.” TR News, (May–June 2014) 292, p. 25–30. See also: United States. Cong. Senate. Committee on Commerce, Science, and

Transportation, *Hands Off: The Future of Self-Driving Cars*, Mar. 15, 2016, 114th Cong. 2nd Sess. (statement of Mary Cummings, PhD, Director, Duke Robotics Professor of Mechanical Engineering and Materials Science, Professor of Electrical and Computer Engineering Duke University).

<sup>13</sup>General Motors, LLC, Receipt of Petition for Decision of Inconsequential Noncompliance, NHTSA, 79 FR 10226, Feb. 24, 2014.



bicyclists, wheelchair users, roadway infrastructure, interactions with law enforcement and first responders, and other objects in the operating environment. A failure to properly detect and react to any of these road users or conditions could have tragic results, as demonstrated by the aforementioned March 2018 crash in Tempe, AZ that killed a woman walking a bicycle. According to the NTSB, the Uber vehicle in driverless mode misidentified the woman three times before the crash. Additionally, research has shown that simple modifications of a standard stop sign could cause an AV system to interpret it as a 45-mile-per-hour speed limit sign.<sup>14</sup>

- *Standard for Over-the-Air Updates:* It is anticipated that updates will be made to AV systems over the air that may change the functionality, capabilities and operational design domain (ODD) of the vehicle. In fact, Tesla is already performing these types of updates. In one reported instance, an update to a Tesla Model 3 left the vehicle without the use of essential safety systems including AEB.<sup>15</sup> To protect against this type of problem and other safety-critical issues that can arise from over-the-air updates, a standard must be issued and provide that consumers be given timely and appropriate information on the details of the update as well as ensure any needed training or tutorials are provided. Safety upgrades should not be optional or force the consumer to incur additional expenses. Also, during the update process cybersecurity must be maintained.
- *Manual Override:* Occupants of a driverless car need the ability to assume control or shut the system down and get to a safe location in the event of a failure. A standard should be established to ensure the capability for a human to assume control of AV when it malfunctions or travels outside the ODD. The manual override must be accessible to all occupants, including people with cross-disabilities, children and other vulnerable populations.
- *Functional Safety Standard:* Functional safety is a process by which a product is designed, developed, manufactured and deployed to ensure that the product as a whole will function safely and as intended. Basically, a functional safety standard assures consumers that a vehicle will do what a manufacturer states it does, will do so safely, and will not operate outside of conditions under which it can operate safely. Legislation should direct NHTSA to establish a functional safety standard that requires a manufacturer to certify to the Agency that an AV has been tested to ensure it will operate reliably and safely under the conditions the vehicle is designed to encounter. Additionally, NHTSA should confirm the manufacturer's certifications are accurate by conducting their own testing as needed.
- *Revising Federal Motor Vehicle Safety Standards:* Any actions by NHTSA to revise existing FMVSS in order to facilitate the introduction of AVs must be conducted in a public rulemaking process and meet the safety need and equivalency provided by current standards.

*Broadening Statutory Exemptions from FMVSS is Unwise, Unnecessary and Unsafe.* Federal safety standards have been established using thorough objective research, scientific studies and data. They are also subject to a robust and transparent public process and ensure the safety and security of all road users. No demonstrable evidence has been presented to show that the development and deployment of AVs requires larger volumes of exemptions from Federal safety standards which are essential to public safety. Current law already permits manufacturers to apply for an unlimited number of exemptions. For each exemption granted, manufacturers can sell up to 2,500 exempt vehicles. The proposed exemption process in the October 28 staff draft and resultant huge numbers of exempt vehicles permitted on the road (potentially millions) *de facto* turn everyone—in and around exempted vehicles—into unknowing and unwilling human subjects in a risky experiment and without an independent institutional review board (IRB). It is also expected that the massive influx of new vehicles exempt from FMVSS will have ramifications (both those that can be predicted or some that cause unintended consequences) for our Nation's infrastructure including changes to or the need to more frequently maintain signage, lane markings, traffic signalization, and others.

There are substantial and grave problems with the staff draft language that pose serious risk to the public. Permitting major increases to exemption numbers beyond

<sup>14</sup>Ivan Evtimov, Kevin Eykholt, Earlence Fernandes, Tadayoshi Kohno, Bo Li, Atul Prakash, Amir Rahmati, Dawn Song, Robust Physical-World Attacks on Deep Learning Models, arXiv preprint 1707.08945, August 2017.

<sup>15</sup>Patrick Olsen, Over-the-Air Update Left Tesla Model 3 Without Key Safety Features, Consumer Reports (Sep. 14, 2018).

the current cap of 2,500 vehicles in a 12-month period will threaten the safety of everyone on the roads by exposing them to even more AVs exempt from FMVSS. Additionally, no metrics or criteria are enumerated for determining that these features or vehicles will be “safety equivalent.” This misguided proposal to drastically revise established Federal law would allow the industry to manufacture a large number of AVs under broad exemptions instead of requiring the Agency to take the necessary action to thoughtfully and thoroughly update and issue new standards specifically for AVs.

The following necessary actions were identified by Advocates in response to the October 28 staff draft:

- 1) Strike the huge increases in exemption numbers. There should be no increase in exemption numbers as manufacturers are already permitted up to 2,500 for sale. There also should be no “stair-step” approach which would allow a manufacturer to simply wait out a time period and get a large number of exemptions;
- 2) Replace the word “or” with “and” in determining safety equivalency as safety equivalency should only be determined if the exempted feature at issue meets the safety purpose and intent of the standard *and* if the vehicle operates at an overall level of safety at least equal to the safety of non-exempt vehicles;
- 3) Remove deadlines for NHTSA review which may limit the Agency’s ability to thoroughly review each application for exemption. Currently, NHTSA lacks the needed resources and/or expertise to accomplish the major responsibility of reviewing multiple applications requesting large volumes of new exemptions. Limiting deadlines will likely lead to the Agency rubber-stamping applications;
- 4) Enumerate criteria for review of previously granted exemptions;
- 5) Prohibit exemptions from crashworthiness standards;
- 6) Include safety-critical information in the exemption database such as the level of the vehicle’s automation and its ODD;
- 7) Require information provided to the Secretary by manufacturers be made public, ensuring transparency;
- 8) Direct that the Secretary immediately review the safety performance of an AV or AV system granted an exemption from FMVSS upon a safety critical event resulting in death or serious injury. If warranted, the Secretary shall issue a do not drive order as well as suspend the sale of any new vehicles under the exemption;
- 9) Provide NHTSA with imminent hazard authority to take immediate action when the Agency determines a defect substantially increases the likelihood of death and injury;
- 10) Remove the current cap on civil penalties; and,
- 11) Provide the U.S. DOT with criminal penalty authority in appropriate cases in which corporate officers who acquire actual knowledge of a product danger that could lead to serious injury or death and fail to inform NHTSA and warn the public.

*Ensuring Proper Oversight of Testing is Fundamental.* Under the FAST Act (P.L. 114–94, Sec. 24404), automakers are permitted to test or evaluate an unlimited number of vehicles that do not comply with FMVSS. Please note that Advocates and other organizations strongly opposed this provision during deliberations on the FAST Act because no safety conditions were required of manufacturers that put experimental vehicles on neighborhood streets and roads. Nonetheless, AV testing is already underway, as affirmed by the University of Florida Transportation Institute which noted that approximately 80 companies are currently testing autonomous technology and AVs in the U.S.<sup>16</sup> The only change Advocates supports to current law is imposing some fundamental and commonsense safeguards to the existing statutory language which should have been enacted in the FAST Act. The need for such protections was underscored when the NTSB noted that “at the time of the [Uber] crash and the writing of this report there was no Federal oversight of the testing of autonomous vehicles.”<sup>17</sup>

The language in the October 28 staff draft broadly expands the eligibility pool for entities that can test, evaluate or demonstrate AVs to “employees, agents, fleet management contractors, or other partners of the manufacturer of the highly automated

<sup>16</sup>Brookings Institution, *Autonomous cars: Science, technology, and policy* (Jul. 25, 2019).

<sup>17</sup>The Operations Factors Group Chairman’s Factual Report (HWY18MH010).

vehicle, the automated driving system, or any component of the vehicle or system; or research institutions, including institutions of higher education and automated vehicle proving grounds.” Taken literally, this language could allow a human resources manager of an AV manufacturer (“employee”), a sales representative of an AV manufacturer (“agent”), an advertising agency of an AV manufacturer (“partner”), or a high school (“research institution”), to name a few examples, to avail themselves of this exemption. Furthermore, essential and basic enforcement authorities to protect the public are missing.

The following are critical actions to protect safety:

- 1) Require that any entity that is testing or evaluating an AV agree to suspend testing if a safety critical event resulting in death or serious injury occurs during testing. The suspension will be in place until the vehicle and testing procedures can be evaluated by NHTSA and corrective measures have been taken by the manufacturer;
- 2) Require any entity that is testing or evaluating an AV to agree to provide the Secretary any and all documentation provided to state authorities;
- 3) Require any entity that is testing or evaluating an AV to agree to establish an Institutional Review Board as defined in 21 CFR Part 56 to evaluate any testing involving human subjects;
- 4) Significantly restrict the expansion of those eligible to test, evaluate or demonstrate the motor vehicles with clear and precise criteria on eligibility;
- 5) Provide NHTSA with imminent hazard authority to take immediate action when the Agency determines a defect substantially increases the likelihood of death and injury;
- 6) Remove the current cap on civil penalties;<sup>18</sup>
- 7) Provide the U.S. DOT with criminal penalty authority in appropriate cases in which corporate officers who acquire actual knowledge of a product danger that could lead to serious injury or death and fail to inform NHTSA and warn the public; and,
- 8) Limit access to vehicles testing on public roads to individuals affiliated with the AV manufacturer.

*Advisory Committees Should be Balanced and Subject to Basic Protocols.* Advisory committees are unacceptable substitutes for the Agency fulfilling its statutory mission and issuing safety standards through open public rulemakings. The work of an advisory committee should in no way impair, constrain or supplant the authority of the Secretary or NHTSA to issue timely regulations, institute oversight actions and propose program policies for AVs. For example, the U.S. DOT should not delay or defer regulatory actions on AVs while awaiting any report, recommendations or approval from any advisory committees.

Rather than expend scarce Agency funds and staff time on an advisory committee, NHTSA should be given the resources to hire experts with requisite knowledge. These types of committees, even so-called “balanced” ones, allow for undue industry influence, as demonstrated by the Boeing tragedy chronicled recently in *The New York Times* on October 27, 2019.<sup>19</sup> Committees are time consuming and drain Agency resources. The October 28 staff draft text lacks clear language indicating that the report/recommendations from the Advisory Council (“Council”) do not in any way delay issuance of rules or affect the ability of the Secretary to issue regulations and other policies. Strict assurance that no interest can have more representation than any other and a general cap on membership numbers is essential. Moreover, the breadth of issue areas is extremely expansive and should not be delegated to an advisory council.

The following are necessary protections to ensure the measured, balanced and structured nature of the Council:

- 1) Significantly reduce the technical purview of the Advisory Council;
- 2) Provide authorization for a dedicated funding source so that the Council does not divert money from NHTSA’s budget;
- 3) Require that members of the Council submit a financial disclosure that is made public;
- 4) Establish a structure of the Council including chairs, voting construct, consensus requirements, and the ability for dissenting members to report;

<sup>18</sup> 49 USC 30165(a).

<sup>19</sup> Natalie Kitroeff and David Gelles, *Before Crashes, Boeing Pushed To Undercut F.A.A. Oversight*, N.Y. Times (Oct. 27, 2019).

- 5) Ensure recommendations made by the Council, records of the Council meetings, meeting announcements and agendas, reports, transcripts, minutes and other documents are made available to the public;
- 6) Enumerate representation of some essential stakeholders including first responders, law enforcement, public health representatives, pedestrians and bicyclists; and,
- 7) Remove the limitation on the applicability of the Federal Advisory Committee Act (FACA (5 USC App.)).

*Issuing a Cybersecurity Standard is Vital for Safety and Protection.* NHTSA must issue a minimum cybersecurity standard by a date certain to protect against potentially catastrophic hacks of AVs. As such, Advocates supports the enactment of the SPY Car Act of 2019 (S. 2182). Numerous high profile cyber attacks on a variety of industries have already occurred, and AVs will not be immune to this threat. In 2015, hackers demonstrated their ability to take over the controls of a sport utility vehicle (SUV) that was traveling 70 miles-per-hour on an Interstate outside of St. Louis, MO by accessing the vehicle's entertainment system using a laptop computer located miles away from the vehicle.<sup>18</sup> Traditional vehicles, which are less complex than AVs, have been weaponized and used in terrorist attacks including in New York City (2017), Toronto, Canada (2018), Berlin, Germany (2016) and Nice, France (2016).

*Privacy Protections Needed to Guard Against Misuse.* AVs will be collecting significant amounts of personal data including the operation and location of the vehicle. Manufacturers must have robust safeguards and policies in place to protect this data from being stolen and/or misused. However, the ability of NHTSA, the NTSB and local law enforcement to access critical crash data in a timely manner must be preserved. In addition, the use of communication bandwidth needed for vehicle-to-everything communication must be limited to non-commercial use.

*Consumers Must Be Given Sufficient Information about AVs.* Every manufacturer should be required to provide consumers with information about the capabilities, limitations and exemptions from safety standards for all vehicles sold in the U.S. During a September 2017 NTSB hearing on the 2016 fatal Tesla crash, the Board correctly criticized the lack of adequate and consistent consumer information about the capabilities, limitations and any exemptions granted for AV systems. Consumer information should be available at the point of sale, in the owner's manual and in any over-the-air updates. NHTSA should be directed to immediately issue an interim final rule (IFR) requiring such readily available information be provided to consumers. Additionally, similar to the user-friendly *safercar.gov* website, NHTSA must establish a website accessible by vehicle identification number (VIN) with basic safety information about the AV level, safety exemptions, and limitations and capabilities of the AV driving system, including any changes made by over-the-air updates. The website will also allow NHTSA and other research groups to perform independent evaluations of the comparative safety performance of AV systems.

*Any Submission to NHTSA Should be Informative and Include Sufficient Data.* Advocates recommends that each manufacturer be required to submit an Autonomous Technology Notice (ATN, formerly referenced by legislation as a "Safety Evaluation Report") as it requires autonomous technology manufacturers to give notice to NHTSA about their planned actions. The ATN is not designed to be, nor can it be, a substitute for NHTSA promptly issuing minimum performance standards through a public rulemaking process. The primary purpose of the ATN is to give notice to the Agency and the public of the intention of the manufacturer to introduce an AV or AV system into commerce and provide documentation of the work undertaken to ensure its safe performance. Any AV produced must still meet all of the FMVSS and the submission of an ATN alone, cannot permit, in any way whatsoever, the sale of an AV that does not meet all applicable Federal safety standards. In addition, if NHTSA finds that an ATN is deficient, manufacturers must be required to submit any additional information requested by the Agency.

AV legislation that requires a publicly-accessible submission to NHTSA must ensure that the report includes sufficient data and documentation necessary to adequately detail and evaluate the subject areas. Merely allowing manufacturers to "describe" their AV system has encouraged manufacturers to submit glossy, marketing-style brochures with little, if any, substantive or relevant information from which to ascertain critical information about safety and performance. As such, legislative language must direct companies to both "describe and document" how they are com-

<sup>18</sup>Andy Greenberg, Hackers Remotely Kill a Jeep on the Highway—With Me in It, *Wired* (Jul. 21, 2015).

prehensively addressing each issue area under the ATN, until a safety standard for that particular issue area has been established.

Past actions by several automakers to hide from the public and NHTSA known safety defects that have caused deaths and serious injuries and led to the recall of tens of millions of vehicles fortify this essential need. An ATN provision must require:

- 1) Submission of false or misleading information be subject to criminal penalties;
- 2) The cap on civil penalties be removed;
- 3) NHTSA to verify the level of automation being asserted by the manufacturer;
- 4) NHTSA be provided with sufficient time, a minimum of six months, to adequately analyze the ATN and request additional information if necessary; and,
- 5) At a minimum the topics covered by the ATN should include: System Safety, Data Recording, Cybersecurity, Human-Machine Interface, Crashworthiness, Capabilities, Post-Crash Behavior, Account for Applicable Laws (*i.e.*, compliance with traffic safety laws) and Automation Function.

*Collect Standardized Data, Make it Publicly Available and Require EDRs.* With the increasing number of AVs of different automation levels being tested and some being sold to the public, standardized recording and access to AV event data are necessary for the proper oversight and analysis of crashes.

The lack of standardization and collection of data is already hampering understanding and investigations of AVs. For example, as a result of the 2016 fatal Tesla crash in Florida, the NTSB has called for the U.S DOT to act on data collection. The NTSB recommended that NHTSA implement data collection requirements for all new vehicles equipped with AV control systems, and to define a standard format for reporting this data. The NTSB also called for this data to be readily available to, at a minimum, the NTSB and NHTSA. This data should also be made public.

Every vehicle should be equipped with an event data recorder (EDR). While there is currently a NHTSA requirement for what data voluntarily-installed EDRs must capture, this information is insufficient to properly ascertain information about crashes involving AVs. IIHS also reiterated the need for EDRs in the August 7, 2018, Status Report: “IIHS has asked the agency to require event data recorders to encode information on the performance of automated driving systems in the moments before, during and after a crash. This information would help determine whether the human driver or vehicle was in control and the actions each entity took prior to the event.”<sup>19</sup>

Other data needs include:

- 1) Manufacturers must be required to report AV safety critical events to NHTSA, including crashes and disengagements;
- 2) NHTSA’s crash databases should be updated to capture AV crashes. This includes a revision of Early Warning Data to ensure manufacturers provide more information about crashes and incidents that could indicate a safety defect and lead to a recall; and,
- 3) A structure should be established to facilitate mandatory sharing of AV failures by manufacturers.

*Provide Additional Resources and Enforcement Authorities.* Ensuring NHTSA has adequate resources, funds, staff and enforcement authority is essential for the Agency to successfully carry out its statutory mission and address the multiple challenges presented by the deployment of self-driving technologies. Even without the upcoming enormous challenges AV development and deployment will create, the Agency is chronically underfunded; NHTSA’s Operations & Research (O&R) budget is meager (only about \$350 million annually in the past 2 years). In fact, this year, the Administration proposed a draconian \$50 million cut in NHTSA’s O&R budget. The Agency cannot effectively oversee a multi-billion dollar industry and protect hundreds of millions of motorists without a significant increase in resources—both financial and staff. Currently, 95 percent of transportation-related fatalities and 99 percent of transportation injuries, involve motor vehicles. Yet, NHTSA receives only one percent of the overall DOT budget. Furthermore, it is estimated that currently more than 70 million cars are on the road with an open recall.<sup>20</sup>

<sup>19</sup> IIHS, Status Report, Reality Check-Research, deadly crashes show need for caution on road to full autonomy, Vol. 53, No. 4 (Aug. 7, 2018).

<sup>20</sup> Consumer Federation of America, Over 70 Million Vehicles On The Road With Open Recalls (Sep. 18, 2018).

Any AV legislation must include the following provisions to address inadequate funds, staff and enforcement ability:

- 1) A significant increase in funding for NHTSA's operations and research (O&R) budget;
- 2) Imminent hazard authority to take immediate action when the Agency determines a defect substantially increases the likelihood of death and injury; and,
- 3) Criminal penalty authority in appropriate cases in which corporate officers who acquire actual knowledge of a product danger that could lead to serious injury or death and fail to inform NHTSA and warn the public.

*Guarantee Access for Individuals with Cross-Disabilities.* Autonomous driving technology has the potential to increase access and mobility for individuals with disabilities who may have varying needs. However, that goal can only be realized by Congressional directive in legislation. People with disabilities have different requirements for access and mobility—AVs may help increase mobility for some members of the disability community but provide little or no assistance to others. Installing an automated system in a vehicle or removing the driver in a ridesharing service will not sufficiently eliminate mobility barriers and may even exacerbate them. For example, wheelchair users may require a ramp or lift system as well as assistance in ensuring the wheelchair is properly secured or stowed during the ride. As such, full accessibility for all users must be required for all types of common and public use AVs. Additionally, funding should be authorized to promote research and development of accessible AVs and standards, including vehicle safety and crash-worthiness standards, and technical assistance.

As previously stated, allowing AVs to be exempt from safety standards is dangerous for all road users, but could pose even more serious problems for people with cross-disabilities should the vehicle be involved in a crash, not function as intended, or have a defect. In the event of a failure, a person could be stranded in the vehicle with no driver. The diverse needs of members of the cross-disability community must be taken into account for systems that require human engagement as well as when developing a failsafe. Should there be an emergency that requires human intervention (such as a manual override), such a safeguard must be useable by any potential occupant of the vehicle regardless of a person's disability.

*Federal, State and Local Roles Should Not be Altered.* The statutory mission of the U.S. DOT established by Congress in 1966 is to regulate the design and performance of motor vehicles to ensure public safety, which now includes automated driving system technology and driverless cars.<sup>21</sup> For more than 50 years, the U.S. DOT through the NHTSA has issued safety standards for passenger and commercial motor vehicles. The role of states is to regulate road safety by the passage of traffic safety laws. However, in the absence of comprehensive and strong minimum Federal standards and regulations to govern the driverless car rules of the road, the states retain a legal right and a duty to its citizens to develop proposals and implement solutions to ensure public safety. There should be no attempt in legislation to prohibit states in any way from advancing AV safety in the absence of Federal rules.

### **Conclusion**

While fully driverless cars may have a future potential to reduce the carnage on our roads and expand mobility, commonsense, lifesaving solutions can and must be implemented now. Advocates urges Congress to direct the U.S. DOT to put the vital safeguards outlined in this testimony in place prior to the wide-scale deployment of unproven driverless cars onto public roads. We look forward to continuing to work with the Committee to make our Nation's roads safe for all.

---

### ATTACHMENT

#### ***Public Opinion Polls Show Deep Skepticism About Autonomous Vehicles***

##### **2019 Reuters/Ipsos Poll<sup>i</sup>**

- 64 percent of Americans said they would not buy a self-driving car.
- 67 percent said self-driving cars should be held to higher safety standards than traditional cars.

---

<sup>21</sup> National Traffic and Motor Vehicle Safety Act of 1966, Pub. L. 89-563 (1966).

**2019 AAA Poll<sup>ii</sup>**

- 71 percent of U.S. drivers surveyed would be afraid to ride in a fully self-driving vehicle.

**2018 SADD/State Farm Survey<sup>iii</sup>**

- When asked to rate how safe they would feel riding in a fully autonomous vehicle on a one-to-five scale with one being least safe and five being most safe, 55.6 percent of high school students polled said one.

**2018 Allianz Global Assistance Survey<sup>iv</sup>**

- 57 percent of Americans say they are not very or not at all interested in utilizing self-driving/autonomous vehicles—up from 47 percent in 2017.
- When asked why they had a lack of interest in self-driving/autonomous cars, 71 percent of respondents cited safety concerns—up from 65 percent in 2017.
- The number of Americans who said they were not very or not at all confident that that self-driving/autonomous cars will develop safely enough to consider using jumped 12 percentage points from 36 percent in 2017 to 48 percent in 2018.

**2018 Cox Automotive Survey<sup>v</sup>**

- 45 percent of respondents believe roadways would be safer if all vehicles were fully autonomous—down from 63 percent who said so in 2016.
- 68 percent of consumers said they'd feel uncomfortable riding in an autonomous vehicle fully driven by a computer.
- 84 percent of consumers think people should always have the option to drive themselves even in an autonomous vehicle.
- 75 percent of respondents believe autonomous vehicles need real world testing in order to be perfected but:
  - 54 percent prefer that this testing take place in a different town or city from where they live;
  - 54 percent would not feel comfortable walking near roads where these tests take place; and,
  - 50 percent would not feel comfortable driving on the same roads where these tests take place.

**2018 ORC International Poll<sup>vi</sup>**

- 69 percent of respondents said they were concerned about sharing the road with driverless vehicles as motorists, bicyclists and pedestrians.
- 80 percent of Americans said that National Transportation Safety Board (NTSB) investigations of crashes involving cars equipped with self-driving technology will be helpful in identifying problems and recommending improvements.
- 84 percent of respondents believe the NTSB should complete these crash investigations before Congress acts on driverless car legislation.

**2018 Public Policy Polling/Consumer Watchdog Poll<sup>vii</sup>**

- When informed that Congress is currently considering legislation to allow more driverless cars onto America's roads, 75 percent of respondents from four states (FL, CA, MI, SD) agreed that we need to apply the brakes on driverless cars until the technology is proven safe.
  - 78 percent of voters agreed in Florida.
  - 71 percent agreed in California.
  - 74 percent agreed in Michigan.
  - 79 percent agreed in South Dakota.
- 76 percent of voters in Florida said they would not be likely to ride in a driverless car if it were available. 69 percent said so in California, 69 percent said so in Michigan and 77 percent said so in South Dakota.
- 84 percent of voters in Florida agreed that there should be regulations in place to help protect the public from public experiments with driverless cars. 87 percent agreed in California, 86 percent agreed in Michigan and 82 percent agreed in South Dakota.
- 80 percent of respondents agreed that Federal and state governments, and not the driverless car industry, should regulate driverless vehicles for the safety of riders, pedestrians and other drivers.
- 56 percent of voters polled said they would be very concerned for their safety as a passenger, pedestrian, bicyclist or other driver on the road if a driverless car service were operating in their city.

- 56 percent of respondents said they were very concerned about the security of the data collected by driverless vehicles.
- 59 percent of voters polled said that they do not think that in their lifetimes, driverless cars will be safe enough to use.

**2018 AAA Poll<sup>viii</sup>**

- 73 percent of American drivers said they would be too afraid to ride in a fully self-driving vehicle, up from 63 percent in late 2017.
- 63 percent of U.S. adults said they would feel less safe sharing the road with a self-driving vehicle while walking or riding a bicycle.

**2018 Gallup Poll<sup>ix</sup>**

- 52 percent of Americans said that even after driverless cars are certified by government auto safety regulators, they would never want to use one.

**2018 CARiD Survey<sup>x</sup>**

- 53 percent of respondents said they would feel somewhat or very unsafe riding in an autonomous car.
- 66 percent of those polled said they think the U.S. government must be involved in regulating autonomous vehicles.
- 75 percent of poll respondents said that if given a choice, they would still rather drive than ride autonomously.

**2018 Morning Consult Poll<sup>xi</sup>**

- 50 percent of U.S. adults said that based on what they have seen, read or heard, they believe self-driving cars are somewhat less safe or much less safe than regular vehicles driven by humans.
- 57 percent of those polled said that based on what they have seen, read or heard, they have a not too favorable or not at all favorable view of self-driving cars.
- 38 percent of respondents said they would not ride in a self-driving car, versus 19 percent who said they would and 35 percent who said maybe in the future.

**2018 Reuters/Ipsos Poll<sup>xii</sup>**

- 67 percent of Americans polled said they were uncomfortable with the idea of riding in self-driving cars.

**2018 Morning Consult Poll<sup>xiii</sup>**

- 67 percent of adults polled were somewhat or very concerned about cyber threats to driverless cars.

**2018 ORC International Poll<sup>xiv</sup>**

- 64 percent of respondents said they were concerned about sharing the road with driverless cars.
- 63 percent said they are not comfortable with Congress increasing the number of driverless cars which do not meet existing Federal vehicle safety standards and would be available for public sale.
- 75 percent of Americans said they weren't comfortable with manufacturers being able to disable vehicle controls, such as the steering wheel, and brake and gas pedals, when an AV is being operated by the computer.
- 73 percent of those polled support the development of U.S. Department of Transportation safety standards for new features related to the operation of driverless cars.
- 81 percent said they support U.S. Department of Transportation cybersecurity rules to protect against hacking of cars that are being operated by a computer.
- 84 percent of Americans said they support uniform U.S. Department of Transportation rules to ensure that the human driver is alert in order to safely take control from the computer.
- 80 percent of respondents support minimum performance requirements for computers that operate driverless cars similar to those for computers that operate commercial airplanes.
- 87 percent said it would be helpful to have a U.S. Department of Transportation website for consumers to look up information about the safety features of a new or used driverless car which they may be purchasing.



**2017 Pew Research Center Survey<sup>xv</sup>**

- 56 percent of U.S. adults surveyed said they would not ride in a self-driving vehicle.
- Of those who said they wouldn't, 42 percent of respondents said they didn't trust the technology or feared giving up control and 30 percent cited safety concerns.
- 30 percent of respondents think that autonomous vehicles will make roads *less* safe for humans if they become more widespread.
- 87 percent of respondents said they would favor a requirement that all driverless vehicles have a human in the driver's seat who can take control of the vehicle in case of an emergency.
- 53 percent of people surveyed said the development of driverless cars makes them feel very or somewhat worried.
- 52 percent said they would feel not too or not at all safe sharing the road with driverless passenger vehicles.
- 65 percent said they would feel not too or not at all safe sharing the road with driverless freight trucks.

**2017 Morning Consult/POLITICO Poll<sup>xvi</sup>**

- 51 percent of registered voters polled said they were not too likely or not likely at all to ride as a passenger in an AV.
- 61 percent of respondents said they aren't likely to buy self-driving cars once they become available.
- 35 percent of those polled said they believe AVs are less safe than the average human driver, compared to 22 percent who said they were safer than human drivers and 18 percent who said AVs were about the same level of safety as the average human driver. Over a quarter (26 percent) said they didn't know or had no opinion.

**2017 Deloitte Study<sup>xvii</sup>**

- 74 percent of U.S. consumers polled said they felt that fully autonomous vehicles will not be safe.
- 68 percent of respondents said an established track record of fully autonomous cars being safely used would make them more likely to ride in one.

**2017 MIT AgeLab and New England Motor Press Association Survey<sup>xviii</sup>**

- 13 percent of respondents said they would be comfortable with a fully autonomous car, down from 24 percent in a similar 2016 survey.
- 48 percent said they would never purchase a car that completely drives itself when asked about their interest in purchasing a self-driving car.
- Of those who said they wouldn't purchase a completely driverless car, 37 percent said they feared a loss of control, 29 percent said they don't trust it, 25 percent said they believe it will never work perfectly, and 21 percent said it's unsafe.

**2017 AAA Survey<sup>xix</sup>**

- 54 percent of U.S. drivers polled feel less safe at the prospect of sharing the road with a self-driving vehicle. Moreover, only 10 percent said they'd actually feel safer sharing the roads with driverless vehicles.
- 78 percent of Americans surveyed said they were afraid to ride in a self-driving vehicle.

**2016 Kelley Blue Book Study<sup>xx</sup>**

- 51 percent of respondents said they would prefer to have full control of their vehicle, even if it's not as safe for other drivers.
- 64 percent said they need to be in control of their vehicle.

**2016 Morning Consult Poll<sup>xxi</sup>**

- 43 percent of registered voters polled said autonomous cars are not safe. About one-third (32 percent) said they are safe, but that's not much more than the 25 percent who said they didn't know or didn't care.
- Majorities of voters found it unacceptable for a rider in a driverless car to text or e-mail, read, watch movies or TV, be drunk or sleep.
- 76 percent said they were as worried about driverless cars operating on the same roads as cars driven by humans.

- When asked broadly about road safety, 80 percent said they were concerned. Likewise, 80 percent of respondents said they were concerned about glitches in an autonomous car’s software.
- Compiled by Advocates for Highway and Auto Safety, November 2019
- <sup>i</sup> Americans still don’t trust self-driving cars, Reuters/Ipsos poll finds, April 2019
  - <sup>ii</sup> AAA Annual Automated Vehicle Survey, March 2019
  - <sup>iii</sup> SADD/State Farm, Teens’ Thoughts Regarding the Future of Vehicle Technology, October 2018
  - <sup>iv</sup> Allianz Global Assistance, Sharing Economy Index, September 2018
  - <sup>v</sup> Cox Automotive, Evolution of Mobility: Autonomous Vehicles, August 2018
  - <sup>vi</sup> ORC International and Advocates for Highway and Auto Safety, CARAVAN Public Opinion Poll: Public to U.S. Senate: Pump the Brakes on Driverless Car Bill, July 2018
  - <sup>vii</sup> Consumer Watchdog, As Americans Hit the Road for Memorial Day, Consumer Watchdog Poll Finds Voters Want Congress to Apply the Brakes on Driverless Cars, May 2018
  - <sup>viii</sup> American Automobile Association (AAA), American Trust in Autonomous Vehicles Slips, May 2018
  - <sup>ix</sup> Gallup, Driverless Cars Are a Tough Sell to Americans, April 2018
  - <sup>x</sup> CARiD and Survey Monkey, How do American feel about autonomous driving?, April 2018
  - <sup>xi</sup> Morning Consult, National Tracking Poll #180339, April 2018
  - <sup>xii</sup> Reuters and Ipsos, Reuters and Ipsos Poll poll of 2,592 participants conducted between Jan. 11–18, 2018, January 2018
  - <sup>xiii</sup> Morning Consult, National Tracking Poll #180108, January 2018
  - <sup>xiv</sup> ORC International and Advocates for Highway and Auto Safety, CARAVAN Public Opinion Poll: Driverless Cars January 2018
  - <sup>xv</sup> Smith, A. and Anderson, M., Pew Research Center, Automation in Everyday Life, October 2017
  - <sup>xvi</sup> Morning Consult and POLITICO, National Tracking Poll #170904, September 2017
  - <sup>xvii</sup> Deloitte Global Automotive Consumer Study, What’s ahead for fully autonomous driving: Consumer opinions on advanced vehicle technology, January 2017
  - <sup>xviii</sup> Abraham, H., Reimer, B., Seppelt, B., Fitzgerald, C., Mehler, B. and Coughlin, J., MIT AgeLab and New England Motor Press Association (NEMPA), Consumer Interest in Automation: Preliminary Observations Exploring a Year’s Change, May 2017
  - <sup>xix</sup> American Automobile Association (AAA), Vehicle Technology Survey—Phase II, March 2017
  - <sup>xx</sup> Kelley Blue Book and Cox Automotive, Future Autonomous Vehicle Driver Study, September 2016
  - <sup>xxi</sup> Nasr, A. and Johnson, F., Morning Consult, Voters Aren’t Ready for Driverless Cars, Poll Shows, February 8, 2016

---

PREPARED STATEMENT OF IAN JEFFERIES, PRESIDENT AND CHIEF EXECUTIVE  
OFFICER, ASSOCIATION OF AMERICAN RAILROADS

### Introduction

On behalf of the members of the Association of American Railroads (AAR), thank you for the opportunity to submit this statement for the record. AAR members include the Class I freight railroads and Amtrak. AAR unites these organizations in working toward a single goal: to ensure that railroads remain the safest, most efficient, cost-effective, and environmentally-sound mode of transportation in the world.

The development of new technologies, including autonomous vehicles, offers the unique opportunity to dramatically improve the safety of our Nation’s roads. These and similar technologies can also help to address many of the challenges our Nation faces in improving our freight-moving capabilities to meet the needs of tomorrow. It is essential that Congress and DOT facilitate the development and incorporation of these technologies with a focus on both of these goals.

### Autonomous Vehicles and Highway-Rail Grade Crossings

A highway-rail grade crossing is a location where a railway and roadway intersect at the same level. There are more than 200,000 of these crossings in the United States, and, unfortunately, in 2018, there were more than 2,200 grade crossing collisions, resulting in 840 injuries and 262 fatalities.

AAR and its members have worked diligently to improve the safety of drivers and pedestrians at grade crossings, and the railroads remain committed to trying to

eliminate grade crossing incidents. AAR promotes the 3 “E”s of grade crossing safety: education of the public about the dangers around railways; enforcement of traffic laws related to crossing signs and property laws related to trespassing; and engineering research and innovation to improve the safety of crossings. The railroads’ efforts have contributed to a 55 percent reduction in the number of annual grade crossing collisions over the last 25 years, including through public safety education and awareness campaigns conducted by Operation Lifesaver. However, regardless of these efforts and advances in train control systems, trains simply cannot stop in time to avoid vehicles or pedestrians at grade crossings, and the vast majority of these accidents are due to mistakes or poor choices made by pedestrians or motor vehicle drivers.

Autonomous vehicles have the potential to substantially improve grade crossing safety by reducing or eliminating human error by motor vehicle drivers. AAR has submitted comments to both the Department of Transportation (DOT) and this and other relevant Congressional Committees in an effort to ensure that highly automated vehicle technologies include such capabilities, and DOT has indicated the importance of grade crossing safety by including a reference in its recent guidance: *Autonomous Vehicles 3.0: Preparing for the Future of Transportation (AV 3.0)*. Motor vehicles must yield to trains, and automated vehicle systems must be designed to recognize and respond appropriately to warning devices and approaching trains. More specifically, AAR encourages DOT and Congress to ensure that autonomous vehicles have the following capabilities:

First, autonomous vehicles should be able to recognize when they are approaching grade crossings by identifying the various signs and pavement markings associated with those grade crossings. There should be sufficient technological redundancies in place in order to ensure that autonomous vehicles retain the capability to make these determinations in various types and degrees of weather conditions, as well as if signage were down or misplaced or if road conditions were seriously deteriorated. Second, autonomous vehicles should be able to detect approaching trains, including identifying locomotive headlights, horns, or bells, and account for any variables that might obstruct their view. Third, autonomous vehicles should not begin crossing tracks unless they will be able to fully move through them. Stopping on tracks because of traffic queueing or other causes creates a dangerous situation that can be prevented with highly automated vehicle technology. Finally, it is important for designers of autonomous vehicles to understand that positive train control (PTC) is not being deployed across the entire rail network, and does not have the capability to communicate train location or speed information to highway vehicles in any event.

The incorporation of the above-mentioned capabilities into highly automated vehicles will save lives. It is imperative that Congress and DOT encourage and foster the development of such technologies.

#### **The Importance and Benefits of a Level Playing Field**

Competition in the freight transportation marketplace is fierce. Railroads welcome this competition, because the industry offers a combination of price and service that freight customers want. In order to ensure that customers continue to reap the benefits of this robust competition for their businesses, however, it is essential that the government not pick winners and losers by creating policies that artificially shift freight from one mode to another.

This principle extends to the regulatory and policy framework surrounding the development and implementation of autonomous or highly automated vehicles. DOT’s *AV 3.0* guidance focuses mostly on highways and notes that DOT “is in the process of identifying and modifying regulations that unnecessarily impede the testing, sale, operation, or use of automation across the surface transportation system” and that DOT “supports an environment where innovation can thrive.”<sup>1</sup> Railroads respectfully suggest that the same openness to regulatory modernization should apply to all modes of transportation.

For example, automation promises to significantly enhance other areas of rail safety beyond grade crossings. Automated technologies can detect a wider range of defects, respond faster, and provide a larger window for action than a safety system that is subject to the limitations inherent in human eyes, minds, and hands. Automated track inspections can reduce track defects, leading to fewer accidents. Likewise, automated inspection of locomotives and freight cars has been shown to reduce the occurrence of broken wheels and other mechanical problems. But unfortunately, due to the current limited regulatory framework, many new technologies can only be used in conjunction with, rather than as a replacement for, manual inspections

<sup>1</sup>U.S. Department of Transportation, *Autonomous Vehicles 3.0: Preparing for the Future of Transportation*, pp. 35 and 41.

required by existing Federal Railroad Administration (FRA) regulations. Railroads can sometimes obtain a temporary FRA waiver from existing regulations, but that process is often cumbersome and uncertain. These regulations discourage investment in innovative technologies.

Because automation in the rail industry is new and unfamiliar, regulators will be pressured to identify and resolve every possible risk before allowing testing or early deployment. That pressure must be resisted, because hesitation will come at a cost to safety. DOT recognized this in the context of autonomous vehicles in *AV 3.0*, when it claimed that “delaying or unduly hampering . . . testing until all specific risks have been identified or eliminated means delaying the realization of global reductions in risk.”<sup>2</sup> DOT should realize these safety benefits for rail, as well, by encouraging early deployment of autonomous or highly automated technology on railroads. Unlocking the many potential benefits of automated technology is just as important for railroads as it is for other transportation modes.

### **General Principles for the Regulation of Automated Technologies**

In formulating a regulatory framework that ensures a level playing field for all modes of transportation and that encourages the realization of the benefits of emerging technologies, railroads urge Congress and DOT to adhere to several principles.

First, limited short-term waivers from existing regulations do not give industry sufficient confidence to invest in new technologies. Regulatory barriers must be overcome in ways that are more enduring than waivers. For example, Congress could direct DOT to make permanent long-standing waivers whose value has been proven through successful implementation. Additionally, DOT could issue waivers of indefinite duration and provide procedures for the expedited conversion of time-limited waivers to permanent waivers or final rules if equivalent or improved safety has been demonstrated.

Second, to the greatest extent possible, carriers and equipment manufacturers should be permitted to continue to create voluntary standards for safety technology. No one has a greater stake in the success of new safety technologies than carriers and their suppliers, and market pressures already incentivize them to create and implement safety technologies that work.

Third, new regulations governing automated operations in the transportation sector should be performance-based, rather than prescriptive. This will focus industry attention and effort on the outcome, rather than on how that outcome is achieved. Performance standards would give industry discretion to experiment with new ways to improve safety, while still being subject to DOT oversight, which would oversee goal-setting, ensure that measures and data are accurate, and impose sanctions if carriers failed to meet their safety targets. As such, employees, customers, and the public at large would still be fully protected.

Fourth, regulation of automated operations should occur at the Federal level to avoid a patchwork of state and local rules that would create confusion and inhibit the deployment of safety technology. State and local laws governing rail safety and operations are already preempted by Federal law and regulation, and it is especially critical to the efficient functioning of the national rail network that the principle of a uniform set of national regulations not be undercut by state or local laws targeting autonomous or highly automated technologies.

Last, as with any new technology, public fear of the unknown is often unfounded but can prove to be a major obstacle. The public can and will read much into what DOT and FRA say, or do not say, on the issue of automated technologies. We urge DOT and FRA to be supportive of innovation and work to facilitate the realization of the benefits of these technologies.

### **Conclusion**

As FRA Administrator Ron Batory has stated, “Technology will move faster than the ink can be applied or dried [on regulations]. And if we don’t unleash technology, it will pass us up.” Autonomous vehicles and highly automated technologies can make our society safer and the movement of freight more efficient than it has ever been. It is essential that DOT and Congress set goals for the incorporation of certain essential capabilities, while also providing a regulatory environment that incentivizes industry to be constantly developing new, and improving existing, technologies.

<sup>2</sup>*Autonomous Vehicles 3.0: Preparing for the Future of Transportation*, op. cit. p. 2.

## PREPARED STATEMENT OF AMERICAN PROPERTY CASUALTY INSURANCE ASSOCIATION

Automated driver assistance system (ADAS) and automated driving system (ADS) technology is evolving rapidly, and the increasing automation of the driving function presents an opportunity for society to improve road safety and mobility. It also presents a challenge for policy makers to develop an appropriate regulatory framework for the testing and deployment of highly automated vehicles or “self-driving” vehicles. As these innovations fundamentally change the nature of driving, property casualty insurers will have a key role to play in encouraging the safe and efficient introduction of advanced vehicle technology. In order to do so, insurers must have access to information and data to innovate and develop services, products and pricing to support the new automotive technologies.

The American Property Casualty Insurance Association (APCIA) is the primary national trade association for home, auto, and business insurers. APCIA promotes and protects the viability of private competition for the benefit of consumers and insurers, with a legacy dating back 150 years. APCIA members represent all sizes, structures, and regions—protecting families, communities, and businesses in the U.S. and across the globe. Together, APCIA members write 53 percent of the automobile insurance in the United States. We offer these comments to provide the Senate Committee on Commerce, Science and Transportation our perspectives on the safe testing and deployment of ADS equipped vehicles.

#### **Safety Standards, Exemptions and Testing of ADS Equipped Vehicles**

As vehicle automation increases, safety standards for the use of vehicle automation on public roads should be established to set clear expectations for the public and provide clear direction for technology developers and manufacturers for compliance. Separate safety standards should be developed appropriate to each level of automation, and regulatory agencies should have enough staff and funding to function effectively and keep pace with the rapidly evolving vehicle technology.

There should be standardization of terminology used to describe both automated driver assistance (ADAS) and automated driving systems (ADS) used for highly automated or “self-driving” vehicles. Common terminology would allow insurers to identify and differentiate systems by performance, for insurance product development and pricing. Common terminology would also enable the public to have a clearer understanding of the technology. Safety evaluation reports provided by developers and manufacturers of these systems should contain enough detail for regulators, insurers and the public to understand the technology, how it works and how to use it properly. Additionally, a public education program should be developed that addresses the proper use of both assisted (ADAS) and automated (ADS) driving systems and the associated risks.

All vehicles, including highly automated vehicles, should meet all Federal and state safety requirements and be capable of complying with all state and Federal motor vehicle laws. Exceptions to existing auto safety laws and motor vehicle safety standards should be rare, limited to only the highest levels (*i.e.*, fully autonomous) of automated driving and should clearly define the levels of automation to which the modification applies. Exceptions should not be made for collision protection standards.

Highly automated vehicle testing standards should address both road and simulated testing, include a variety of road, weather and traffic conditions and apply to vehicles intended for both personal and commercial transportation.

#### **Development of a Single Data Access Standard and Data Set**

As the driving function becomes increasingly automated, it will be necessary for insurers to determine what automated driving technology was engaged and how the vehicle was being operated at the time of an accident. Just like a human driver stores his or her recollections of an accident, automated driving systems should be capable of recording and reproducing data about how the vehicle was being operated, and the information used by the system to operate the vehicle. This includes, but is not limited to, what driving function the system was performing, speed of travel, braking and steering status, objects and other vehicles detected by cameras and sensors as well as information to determine if an automated vehicle operating system software was up to date at the time of the accident. Insurers will need access to accident data, pictures and video from an automated driving system on reasonable terms and in easily usable formats to allow for prompt resolution of claims for damage and injury arising from the accident.

To facilitate that exchange, APCIA urges Congress to direct the appropriate Federal agencies to create a single standard for automated vehicle data access that follows the precedent of the Driver Privacy Act of 2015 which allows the vehicle owner to authorize access without the involvement of a third party (such as the manufac-

turer), provides access via court order or subpoena and provides access for federal, state and local government for safety research or for emergency response.

As part of the development of the data access standard, Congress should direct the appropriate Federal agencies to work with state motor vehicle regulators and insurance regulators to develop a standard set of data elements to be recorded by an automated vehicle for crash investigation purposes.

#### **Federal, State and Local Roles and Access to Courts**

APCIA supports preservation of the current division of Federal and state regulatory responsibilities for motor vehicles, with the Federal government setting and enforcing safety standards for motor vehicles and recalls, as well as setting requirements for large vehicles. The states should continue to have primacy on motor vehicle “rules of the road”, liability issues, insurance requirements and regulation, as they do today. APCIA believes that our state based legal liability system has proven to be very adaptable to new technology and as such, APCIA opposes blanket immunity for manufacturers as well as strict liability imposed on vehicle owners for accidents involving automated vehicles.

#### **Cybersecurity and Privacy**

To protect the safety of the users and other motorists, standards for automated and connected vehicle systems should address protection of safety critical systems against cyber-attack. There should also be standards in place to protect the privacy of vehicle owners and users. However, ensuring the vehicle owners ability to authorize sharing of vehicle data on a secure and transparent basis, must be an essential element of the cybersecurity or privacy regulatory framework for automated vehicles.

#### **Advisory Committees**

The insurance industry has an essential role to play in encouraging the safe and efficient introduction of advanced vehicle technology, and the industry should be represented on any advisory committee related to automated vehicle safety or liability issues. APCIA would support an advisory committee on data access, however such an advisory committee should be in addition to, and not take the place of legislative language that would establish a data access framework as recommended earlier in these comments.

#### **Conclusion**

Automated driving technology holds great promise for the future, and implementing clear standards for safety, maintaining the current Federal and state roles in regulating automated vehicle technology and ensuring that insurers have access to vehicle data on reasonable terms to efficiently handle claims, develop products and underwriting methods are an essential first step toward that future. APCIA and its members stand ready to assist members of Congress and look forward to working together to establish a regulatory framework for automated driving.

---

PREPARED STATEMENT OF JOHN BOZZELLA, PRESIDENT AND CEO,  
ASSOCIATION OF GLOBAL AUTOMAKERS, INC.

On behalf of the Association of Global Automakers (“Global Automakers”), I am pleased to provide the following statement for the record of the Senate Committee on Commerce, Science, and Transportation hearing entitled “Highly Automated Vehicles: Federal Perspectives on the Deployment of Safety Technology.” We commend Chairman Wicker, Ranking Member Cantwell, Senators Thune and Peters and other members of the Committee in their continued interest in automated vehicles and ensuring the safe deployment of advanced technologies on the Nation’s roadways.

Global Automakers represents the U.S. operations of international motor vehicle manufacturers, original equipment suppliers, and other automotive-related companies and trade associations. Our companies are technology leaders, bringing a wide range of fuel-efficient technologies for gasoline, plug-in, battery-electric, and fuel cell electric cars and trucks, and innovating in the areas of connected and automated technologies as well.

Global Automakers’ companies have made significant investments in the development and testing of automated driving systems (ADS) in the United States. These technologies can help address the persistent transportation challenges that affect safety, mobility, and economic growth in the United States.

There were 36,560 fatalities on U.S. roadways in 2018. Millions more crashes resulted in injuries and costly medical bills and repairs. Increased travel demands

have placed additional burden on existing roadway infrastructure, often leading to congestion. Travel times for moving people, goods and services increase annually, hampering economic efficiency and growth, as well as productivity and quality of life. Congestion also wastes energy and increases emissions.

We therefore need to identify new opportunities to integrate highly automated vehicles (HAVs) and other intelligent transportation technologies, such as V2X communication, that will help modernize the U.S. transportation system and provide people with safer, cleaner, more efficient, and accessible mobility options.

The challenges associated with the successful integration and implementation of these new technologies and systems are substantial—from both a technology and policy standpoint. Further, public acceptance is critical to widespread adoption and to maximizing the benefits offered. Thus, successful integration of automated vehicle technologies will require a holistic approach that recognizes and balances the input of technology developers, infrastructure owner-operators, transportation service providers, and the public.

Safety is a priority for Global Automakers' members. We recognize the important role of both public and private sector organizations in providing the necessary assurances that key issues of concern are being addressed. In 2017, the Department of Transportation (DOT), through NHTSA, issued guidance *to support the automotive industry and other key stakeholders as they consider best practices relative to the testing and deployment of automated vehicle technologies*.<sup>1</sup> Since then, the Department issued further guidance, adopting a more multimodal approach, while also seeking to address policy uncertainty and helping define processes for engaging with DOT (and its composite agencies).<sup>2</sup> NHTSA has also taken initial steps toward addressing potential barriers within existing Federal Motor Vehicle Safety Standards (FMVSS), and it is imperative these rulemaking efforts advance swiftly to ensure HAVs are not otherwise prohibited from being deployed as a consequence of legacy regulations.<sup>3</sup> Federal agencies have also been actively engaged in responding to safety incidents occurring on public roads, exercising both their investigative and enforcement authority, and providing additional direction and recommendations as appropriate.

Additionally, the automotive industry has been proactive in its own efforts to advance the safe testing of ADS on public roads. The development of new technology is often an iterative process driven by continuous improvement, not just in terms of advances in the technology itself, but also in the processes used for testing and evaluation. In this regard, a number of OEMs, suppliers, technology companies, and other standard-setting organizations have, through individual and collaborative engagements, launched efforts to share and make available best practices, recommendations, and principles designed to address potential safety challenges.<sup>4,5,6,7</sup> Additional efforts to educate the public, through consortia such as the Partners for Automated Vehicle Education (PAVE), also provide awareness of new technology and perspectives on how automated vehicle safety is being considered.<sup>8</sup>

The rapid pace of innovation, in which existing paradigms and models may not best apply, presents new challenges for policymakers. Congress has a key role to play in advancing the testing and deployment of automated vehicles and establishing the United States as a leader in transportation innovation—particularly as other countries move forward in seeking to address these same issues.

We encourage Congress' continued engagement in ensuring that existing regulations are modernized to accommodate highly automated vehicles. Legislation is also necessary to enable meaningful deployment of these advanced driving technologies given that existing regulations, understandably, did not envision the emergence of vehicles capable of operating without the engagement or presence of a driver. A uni-

<sup>1</sup>Automated Driving Systems 2.0: A Vision for Safety, U.S. Department of Transportation (DOT) National Highway Traffic Safety Administration (NHTSA), DOT HS 812 442, September 2017.

<sup>2</sup>Preparing for the Future of Transportation: Automated Vehicle 3.0, U.S. Department of Transportation (DOT) National Highway Traffic Safety Administration (NHTSA), October 2018.

<sup>3</sup>NHTSA ANPRM Removing Regulatory Barriers for Vehicles With Automated Driving Systems (see: 84 FR 24433)

<sup>4</sup>NHTSA Voluntary Safety Self-Assessment Homepage—<https://www.nhtsa.gov/automated-driving-systems/voluntary-safety-self-assessment>

<sup>5</sup>SAE-IITC AVSC Best Practice for in-vehicle fallback test driver (safety operator) selection, training, and oversight procedures for automated vehicles under test—<https://avsc.sae-itc.org/principles-01-5471WV-42925L3.html?respondentID=23171787#Started>

<sup>6</sup>SAE J3018 (2019)—[https://www.sae.org/standards/content/j3018\\_201909/](https://www.sae.org/standards/content/j3018_201909/)

<sup>7</sup>SAFETY FIRST FOR AUTOMATED DRIVING—<https://newsroom.intel.com/wp-content/uploads/sites/11/2019/07/Intel-Safety-First-for-Automated-Driving.pdf>

<sup>8</sup>Partners for Automated Vehicle Education (PAVE)—<https://pavecampaing.org/>

form approach to policies can ensure that these life-saving technologies can be made available to the public nationwide in the safest way possible.

Global Automakers and our member companies look forward to working with the Committee to help bring the benefits of connected and automated vehicles to the American people.

Thank you for your continued attention to this important issue.

---

PREPARED STATEMENT OF THE NATIONAL ASSOCIATION OF MUTUAL  
INSURANCE COMPANIES

The National Association of Mutual Insurance Companies (“NAMIC”) is pleased to offer comments on the United States Senate Committee on Commerce, Science, and Transportation on Federal perspectives on the deployment of safety technology for highly automated vehicles.

NAMIC is the largest and most diverse national property/casualty insurance trade and political advocacy association in the United States. Its 1,400 member companies write all lines of property/casualty insurance business and include small, single-state, regional, and national carriers accounting for 50 percent of the automobile/homeowners’ market and 31 percent of the business insurance market. NAMIC has been advocating for a strong and vibrant insurance industry since its inception in 1895.

These comments are submitted in response to the committee’s interest in perspectives on the safe testing and deployment of highly automated vehicles, as well as recommendations for realizing the potential safety benefits of such vehicles.

The development of Automated Driving Systems (ADS) may be the most consequential transportation issue of our time. New technology and novel service strategies promise faster and better mobility that will be less expensive, and more environmentally friendly. Spring boarding from existing and widely accepted “assisted driving” systems such as cruise control, ADS developers promise a wider array of functions from greater driver assistance to vehicles that will perform every driving operation with no human intervention.

**Safety Must Be the Primary and Overriding Focus**

The single most important reason to support the development of ADS is the potential to enhance safety and save lives. While the idea of working, napping, or watching a movie while the car drives itself may be enticing to many, enhanced safety must always be the primary focus of ADS development. ADS that are proven safer than existing drivers will have innumerable benefits to society. However, the development and deployment of proven, safe ADS will require significant technological advances, revisions to the regulatory paradigm, and the active participation of all the stakeholders.

The potential for technology to move the needle on crash statistics is extraordinary; however, there will still be crashes, especially in an environment where autonomous vehicles continue to share the road with human drivers. It is important to note that ADS, in and of themselves, do not fundamentally change the legal theories of liability associated with motor vehicle crashes. As these ADS crashes happen and questions of liability arise, insurance will play a crucial role for ADS manufacturers, suppliers, owners, operators, and passengers.

Safety must be the primary goal for ADS development but defining and proving what “improved safety” means for ADS is not simple. Currently, Federal auto safety regulations focus more on the structure and design of vehicles and less on the driving operations that are subject to human control. With ADS, the vehicle will assume driving operations formerly performed by the human driver. Thus, the safety responsibilities of the vehicle will expand and will continue to expand until the vehicle assumes all driving operations without any human control. On the one hand, most car crashes involve driver error and ADS promises computer systems that will not replicate the conditions that lead to those errors—i.e. sleeping, intoxication, distraction, or speeding.

According to the NHTSA, “Fully automated vehicles that can see more and act faster than human drivers could greatly reduce errors, the resulting crashes, and their toll.” On the other hand, the elimination of certain human errors does not tell us anything about the introduction of computer, sensor, or software error. Safe ADS will require a substantial amount of specialized software, sensors, controllers, and actuators to collectively perform without error, or at least as well as those human drivers, the large universe of operations that human drivers already perform. The bar for performance has been set high: human drivers in 2017 averaged 500,000 ve-



hicle miles between crashes, more than one million vehicle miles between crashes with an injury and nearly 100 million vehicle miles between fatal crashes.<sup>1</sup>

The development of ADS will require a new way to look at the fundamental nature of driving, and that development should not be hindered by requiring outdated safety requirements that do not apply to new technologies. At the extreme end of the spectrum, the development of ADS with no driver controls will mean that vehicle features that are now required for human operation may not be necessary or practical. Sound policy should include a review of which requirements would no longer be relevant for a fully autonomous vehicle. The Federal Motor Vehicle Safety Standards (FMVSS) are the U.S. Federal regulations specifying nationwide design, construction, performance, and durability requirements for auto-safety-related components, systems, and design features.

FMVSS focus mostly on crash avoidance, crashworthiness, and crash survivability. Existing FMVSS specify that controls and displays must be located where they are visible to or within the reach of a person sitting in the driver's seat. Depending on whether the occupants have "dual mode" or no control of an ADS, there may not be a "driver's seat" or the relevant controls or displays of driving operations may vary with the driving operations that the human retains. In various iterations of ADS, auto parts subject to FMVSS such as rearview mirrors may or may not be superfluous for driving operations. Similarly, controls for turn signals, lights, or wipers may or may not be required and may or may not be subject to safety standards.

The focus must remain on ensuring that critical safety aspects are examined and validated and that any safety assurance gaps that may be created by the introduction of ADS onto the roads are identified and addressed. This is far more complicated than it may seem. While many human-driver focused FMVSS do not make sense for ADS, perhaps ADS-specific safety tests should accompany broad exemptions. Existing self-certification should be supplemented by governmentally defined and publicly disclosed standards and then supplemented by third-party validation of design and testing. Pre-market approval has many downsides, but some level of independent ADS safety review could supplement self-certification.

#### **Insurance Companies Have the Expertise to Enhance Safe Testing and Deployment of Highly Automated Vehicles**

Insurers have long championed auto and highway safety issues and have helped raise public awareness through the creation and ongoing support of auto safety research organizations such as the Insurance Institute for Highway Safety and the Highway Loss Data Institute. The Insurance Institute for Highway Safety is an independent, nonprofit scientific and educational organization dedicated to reducing the losses—deaths, injuries and property damage—from motor vehicle crashes. The Highway Loss Data Institute shares and supports this mission through scientific studies of insurance data representing the human and economic losses resulting from the ownership and operation of different types of vehicles and by publishing insurance loss results by vehicle make and model. Insurers have allied with safety groups to work together to make America's roads safer.

The critical issues related to passenger safety, liability, and recovery after a crash require that insurance companies are included in the development, deployment, regulation, and use of ADS, including any NHTSA research program. Consumers will continue to look to property/casualty insurers to provide them with the protections they have come to expect as this new frontier of automotive products and services evolves. A 2018 JD Power survey found that consumers have the highest levels of confidence in insurance dealing with ADS.<sup>2</sup>

The business of insurance demands that it applies hard data and institutes actuarial science to assess and mitigate risk. It was more than 30 years ago that coalitions of insurance companies together with consumer groups first favored state requirements for seat belts and air bags and opposed the auto makers reluctance to provide such safety features.

Insurers have a long and proven history of working hand-in-hand with regulators and auto manufacturers to facilitate developments that save lives and prevent injuries and damage. The revolutionary replacement of the human driver with ADS will require auto insurers to understand each vehicle's design and operation. Ultimately, drivers may not be comfortable with "dual mode" or no control whatsoever, which means that the insurer of that human driver must fully understand the planned

<sup>1</sup> US Department of Transportation Bureau of Transportation Statistics <https://www.bts.gov/content/motor-vehicle-safety-data>

<sup>2</sup>Automated Vehicles and Insurance Pulse Survey, [https://www.namic.org/pdf/18member\\_advisory/181008\\_Automated\\_Vehicles\\_JD\\_Power\\_NAMIC\\_Questionnaire.pdf](https://www.namic.org/pdf/18member_advisory/181008_Automated_Vehicles_JD_Power_NAMIC_Questionnaire.pdf)

automated driving operations as well as any possible human operation of the vehicle under any circumstances.

The insurance industry understands that new and different data will be needed for insurers to write ADS-related insurance policies. The extensive history and level of human driving data that insurers have developed must now be supplemented by increasingly complex data on the automated driving systems that assist or replace those human drivers. Insurers have a proven record of assessing driving risks and communicating to auto owners the methods to mitigate that risk.

#### **Defining and Analyzing the Appropriate Safety Data is Critical**

Insurers should have access to a robust ADS information and data framework—including crash accident and incident information and data for businesses purposes including underwriting and rating—that is timely, complete and useful. It is critically important for Congress to address these issues when writing any legislation for the development and deployment of automated vehicles.

The types of objective and verifiable data that will be required to provide insurance for ADS—data on frequency, severity, and repairs—are the same types of data that can authoritatively validate safety levels of ADS to the public and regulators. Auto insurance rates and coverage are established by insurance companies using vast amounts of historical data and established actuarial science, analyzing years of relevant data on frequency and severity of incidents. The rates determined by insurance companies are then frequently subject to a review by the state insurance regulators to ensure that they are fair and supported by data.

Valid and understandable data on ADS is critical to safety. The development and deployment of ADS—particularly the proposed ADS with “dual mode” or no controls for a human driver—is a game changer. It will entail a fundamental change in transportation, mobility, infrastructure, and myriad other areas. The adoption of ADS on a wide scale will impact millions of people and will require adaptation by governments, industries, and the culture in general. The precondition to this development is an accepted belief that ADS improve safety, which will itself require sufficient data and information upon which to validate that belief. To date, information about ADS development in general and safety specifically has been limited.

ADS development is still in the early stages and myriad business, design, technical, and other issues are still only being discussed. In the competition to bring ADS to market, there should be a requisite level of confidentiality. Insurance companies understand confidential information and have a long history of working with auto companies to obtain and use available data. Similarly, insurance companies have deep experience in data security and the wide scope of data privacy requirements.

At the same time, there is a significant level of concern that this system of voluntary self-certification by manufacturers of the safety of ADS may not be adequate to enable the development and public acceptance of safe ADS. Having defined and transparent government standards will result in more and better data and information on ADS that will help its development, the understanding and acceptance by the public of ADS, and the development of related businesses like insurance that will be critical to ADS use.

It would be in the best interests of proponents of safe ADS to coordinate and consider new and improved alternatives to communicate on ADS technology and performance. Somewhere between the extreme poles of “just trust us” and reams of Federal regulations requiring submission of millions of certified data points is a system of information and communication that is usable and comprehensible for the public, governments, and other industries. Validation of safe ADS development and a resulting public acceptance can be greatly enhanced by a measurable gauge of ADS safety/risks through recognized analysis of most relevant data. Insurers, with their direct and ongoing contact with drivers and owners, are a most effective way to enhance that communication.

#### **Conclusion**

The insurance industry has continuously proven its commitment to supporting the development and deployment of real auto safety benefits at the earliest time. For ADS, these benefits are dependent, however, on many and daunting technological, logistical, and regulatory revisions that remain to be designed and successfully implemented. The existing environment of auto safety regulation evolved with a human-driver focus and has not fully considered the many nuances of increased assisted and automated driving systems. As these systems develop and evolve, the risk of regulatory safety gaps increases and the need for a comprehensive reassessment of driving operation safety grows exponentially, starting with the paramount focus on the safety of vehicle occupants, occupants of other vehicles, and the public.

For the public to understand and accept ADS safety developments<sup>3</sup>, we must show how we got to the answer; to illustrate the exact steps taken to achieve specific metrics of safety for ADS. Broad assurances of overall safety must be bolstered by facts and data on ADS design and operation. Third party validation of ADS data and safety testing by insurers will help to develop the requisite public, insurer, and governmental trust to support further ADS deployment.

A prerequisite of that trust, particularly for insurers, is the access to more and better data on the proposed and adopted design and operation of ADS. Through their highly regulated development of rates and coverage, insurers apply many of the objective and independent validations sought for ADS operational safety. Just as with the established and active advocacy of seat belts and air bags, auto insurance companies can work with auto manufacturers and safety advocates to develop and implement commercial standards that can save lives.

---

PREPARED STATEMENT OF THE NATIONAL SAFETY COUNCIL

Thank you for allowing the National Safety Council (NSC) to submit this statement for the record. NSC is a 100-year-old nonprofit based in Itasca, Ill., with a mission to end preventable deaths in our lifetime at work, in homes and communities and on the road through leadership, research, education and advocacy. Our more than 16,000 member companies represent employees at more than 50,000 U.S. worksites. These members are across the U.S. and likely are in each district represented on this Committee.

The National Safety Council estimates that approximately 40,000 people were killed in motor vehicle crashes in 2018.<sup>1</sup> Your timing for this hearing is critical. As we enter the holiday season, NSC estimates that U.S. roads will experience 417 fatalities over the Thanksgiving holiday, and another 47,500 people may be seriously injured.<sup>2</sup>

Included here are the number of people killed in motor vehicle crashes in 2018 from the Chairman's and Ranking Member's states.<sup>3</sup>

Mississippi	664
Washington	546

These are the lives of your constituents. These mothers, fathers, sisters, brothers, aunts and uncles contributed to the communities in which they lived. Yet, our national outrage at these losses is conspicuously absent, particularly when you compare to deaths in other forms of transportation, such as aviation. These crashes and deaths on our roadways not only have a human toll, but there is an annual cost to the American economy of over \$433 billion.<sup>4</sup> The U.S. has consistently avoided the hard choices needed to save lives on the roadways, and NSC calls on Congress to act in a bipartisan manner to implement policies that will save lives. We know the solutions; we need the will to enact them.

---

<sup>3</sup> A 2019 Reuters/Ipsos poll, half of U.S. adults think automated vehicles are more dangerous than traditional vehicles operated by people, and more than 60 percent of respondents would not pay more to have a self-driving feature on their vehicle. Americans still don't trust self-driving cars, Reuters/Ipsos poll finds, at <https://www.reuters.com/article/us-autos-self-driving-poll/americans-still-dont-trust-self-driving-cars-reuters-ipsospoll-finds-idUSKCN1RD2QS> AAA reports that more than 70 percent of Americans are afraid to ride in a self-driving car, an increase from 63 percent in 2017. Three in Four Americans Remain Afraid of Fully Self-Driving Vehicles, at <https://newsroom.aaa.com/2019/03/americans-fear-self-driving-cars-survey/>

<sup>1</sup> <https://www.nsc.org/in-the-newsroom/2018-marks-third-straight-year-that-motor-vehicle-deaths-are-estimated-to-have-reached-40000>

<sup>2</sup> <https://injuryfacts.nsc.org/motor-vehicle/holidays/thanksgiving-day/>

<sup>3</sup> <https://cdan.nhtsa.gov/STSI.htm#>

<sup>4</sup> <https://injuryfacts.nsc.org/motor-vehicle/overview/introduction/>

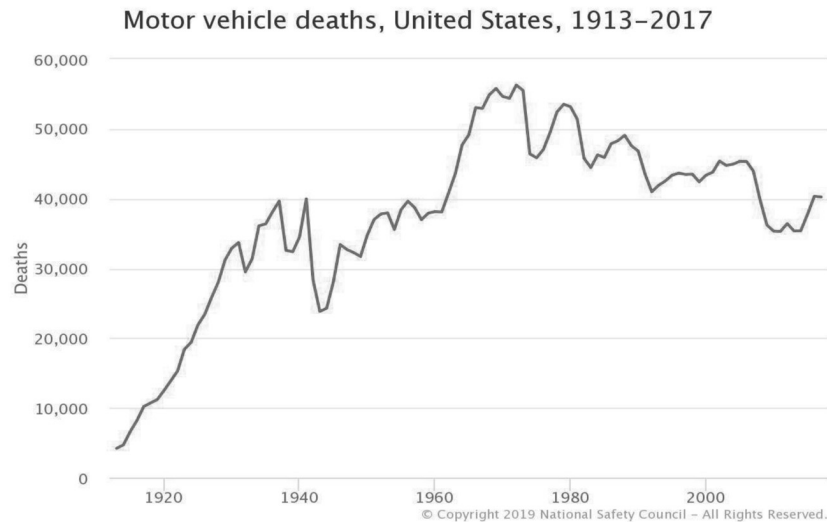

### Road to Zero

NSC is so committed to the goal of zero deaths on the roadways that we lead, in partnership with the U.S. Department of Transportation, the Road to Zero Coalition, a diverse group of over 900 members committed to eliminating roadway fatalities by 2050. Over the past two and a half years, the coalition has grown to include members from across the country representing transportation organizations, businesses, academia, safety advocates and others, the first time so many organizations have collaborated to put forth a plan to address fatalities on our roads.

The centerpiece of the coalition's work has been the creation of the *Road to Zero* report, a comprehensive roadmap of the strategies necessary to achieve its goal by 2050. In April 2018, the coalition issued its report with three primary recommendations.

1. Double down on what works through proven, evidence-based strategies
2. Accelerate advanced life-saving technology in vehicles and infrastructure
3. Prioritize safety by adopting a safe systems approach and creating a positive safety culture

### The Lifesaving Potential of Advanced Technology

NSC believes advanced vehicle technology, up to and including fully automated vehicles, can provide many benefits to society. The most important contribution will be the potential to greatly reduce the number of fatal crashes on our roadways. Federal leadership on motor vehicle safety is necessary because there should only be one level of safety. Consumers need confidence in vehicles regardless of where they reside; manufacturers need certainty in order to invest in design and production, and states do not possess the expertise and the resources to replicate design, testing and reporting programs. Further, a patchwork of requirements will result in confusion for consumers and increased cost for manufacturers and operators attempting to comply with a myriad of requirements. Finally, the absence of a safe, workable standard will drive development, testing and deployment overseas, resulting in the flight of innovation and the jobs that accompany it to locations outside of the U.S.

To reach zero deaths, we need to encourage the development of innovations that address human errors and road design failures and, once proven, establish mandates for adoption of technologies that work. The potential safety benefits of automated vehicles could be incredible; however, it will be decades before we have meaningful fleet penetration on U.S. roadways of AVs.

One of the biggest challenges in moving from level 1 to level 4/5 vehicles is successfully identifying the improvements needed for the human-machine interface to be successful. In other industries, such as aviation, there have been many lessons learned regarding mode confusion and overreliance on automation. We must recognize that the most dangerous environment will exist when both the human and ma-

chine are involved in the safe operation of a vehicle. The greatest risks are not when one or the other has sole responsibility for the vehicle, but when the control is shared.

Advanced Driver Assistance Systems (ADAS) can prevent or mitigate crashes. Consumer education about these new technologies is of utmost importance, and NSC is expanding consumer education around these new technologies. NSC and the University of Iowa created the first and largest ADAS national campaign at *MyCarDoesWhat.org*, to help. When a person visits *MyCarDoesWhat.org*, he or she learns about dozens of existing safety features such as lane departure warning, blind spot monitoring, backup cameras, automatic emergency braking and more. The purpose of *MyCarDoesWhat* is to educate the public about these assistive safety features in order to maximize their potential lifesaving benefits.

Another way to advance consumer understanding is to standardize the nomenclature or taxonomy for advanced technologies. NSC recommends that, at the very least, systems that are not fully automated or Level 5 should not be described as such. ADAS, with emphasis on driver assist, represents the vehicles being sold today and requires drivers to remain fully engaged in the driving task. That fact is often lost in marketing, media reports and consumer expectations. Labeling a motor vehicle as “automated” or “autonomous” today, or even using terms such as “autopilot,” only confuse consumers and can contribute to losses of situational awareness around the driving task. By establishing standard nomenclature and establishing clear performance outcomes, consumers will better understand what they should expect from these technologies.

Today (Nov. 20), NSC, in collaboration with AAA, Consumer Reports, and J.D. Power, released recommendations to standardize nomenclature in order to help educate consumers on the benefits, limitations, and proper use of these new technologies. (See [www.nsc.org/in-the-newsroom](http://www.nsc.org/in-the-newsroom) for more details.) The four organizations agreed on standardized naming that is simple, specific, and based on system functionality in an effort to reduce consumer confusion. Today, 93 percent of new vehicles offer at least one ADAS feature and while the technology has the potential to improve safety and save lives, the terminology prioritizes marketing over clarity. We urge other safety organizations, automakers, journalists, and lawmakers to join us in adopting these terms.

Additionally, the National Safety Council was a founding member of PAVE (Partners for Automated Vehicle Education), which launched in January of 2019. PAVE is a broad-based coalition that includes automotive and technology companies, safety and mobility advocates and community partners. PAVE members believe that in order to fully realize the benefits of self-driving technology, policymakers and the public need factual information about the present and future state of such technology. PAVE enhances public understanding through a variety of strategies including an educational website at [PaveCampaign.org](http://PaveCampaign.org), “hands-on” demonstrations allowing the public to see and experience driverless technology and workshops to help understand the technology. In the future, PAVE will produce educational toolkits for car dealers to help them communicate more effectively with customers about their vehicles’ capabilities and limitations. PAVE is focusing on levels 4 and 5 vehicles.

Finally, the New Car Assessment Program (NCAP) program has operated for nearly 40 years with a goal of testing vehicle safety systems and educating consumers about them. Practically, it has created a mechanism to allow consumers to evaluate vehicles on safety systems. NSC supports NCAP, and expanding its role into ADAS safety, believing it is an important program to improve the safety of the motor vehicle fleet.

### **Data Sharing**

Congress should facilitate data sharing as widely as possible and require that manufacturers provide accessible, standardized data to law enforcement, state highway safety offices, investigators, insurers, and/or other relevant stakeholders. Collecting and sharing de-identified data about near misses and other relevant problems could also help to aggregate useful information for the motor vehicle industry, allowing it to take proactive steps based on leading indicators rather than waiting for a crash or a series of crashes to occur. Finally, these data will be useful to researchers and the safety community in analyzing the safety benefits—and potential drawbacks—of these technologies as they continue to mature.

Acquiring an understanding of what happens when systems perform as intended, fail as expected, or fail in unexpected ways yields valuable information for manufacturers—some of whom have common suppliers. Further, in-service data, as well as near miss and post-crash information sharing, can help civil engineers and planners design better and safer roadways, as well as help safety and health professionals design better interventions to discourage risky driving or affect the behaviors of

other roadway users. NHTSA has begun work toward data sharing, and we urge Congress to support this effort.

### Prioritizing Safety

By prioritizing safety, we commit to changing our Nation's safety culture. This means we have to accept that any life lost is one too many. Once we accept that one death is too many, we will begin thinking about how to take a "safe systems" approach to our roadways. Fully adopted by the aviation industry, this approach features fail-safe systems that anticipate human error and develop infrastructure with safety margins. When it comes to technology, the U.S. prioritized safety years ago by dedicating spectrum for safety purposes to prevent crashes. Today, other groups would like to take the spectrum for streaming services. I urge this committee to direct the U.S. DOT, the Federal Communications Commission, the Department of Commerce and others to maintain the spectrum for roadway safety purposes allowing vehicles to communicate with each other, infrastructure, pedestrians and others to prevent crashes. This spectrum provides a safety margin that we cannot afford to give away.

While infrastructure change may not seem like "high tech," this is a known solution for increasing safety and should be encouraged throughout the U.S. For example, in the pictures below, a multi-lane intersection with a red light in Scottsdale, Ariz., was replaced with a roundabout. With the intersection, there are 32 potential points of failure, but with a roundabout, those points of failure are engineered down to only eight. Speeds are decreased, and if crashes do occur, they occur at angles that are not as violent.



Infrastructure changes do not have to be expensive. Through the Road to Zero Coalition, NSC has awarded grants to groups across the country working in communities of all sizes. The biggest and hardest change is the shift to truly prioritize safety by changing safety culture on the roads. We cannot be complacent when it comes to losing so many people each and every day on our roads. We need leaders in this area, and there are none better than the members of this Committee. We have changed safety culture in workplaces, around seat belt usage, around child passenger safety seats and in other areas. We can do it here too with your help.

### Conclusion

Today, we have millions of drivers behind the wheel, spend millions of dollars on education and enforcement campaigns, and still recognize billions in economic losses as a result of crashes. In spite of safer vehicle designs and record-setting seat belt use rates across the nation, operating a motor vehicle remains one of the deadliest things we do on a daily basis. The integration of some of these technologies will likely be messy as we deal with a complex and ever-changing human-machine interface. There will be an evolution of the existing technologies and perhaps a revolution when it comes to new and different technologies. We need to be prepared for unanticipated consequences and new failure modes.

For these reasons, NSC respectfully urges the Committee to keep the following policies and potential barriers in mind:

- How will cars with newer technologies such as those with "self-driving" features, interact with cars that are not equipped with this capability? How will they interact with pedestrians?
- The formal regulatory process can take many years to finalize. Mandates, as well as the potential for a mandate, can spur adoption by manufacturers.<sup>5</sup>

<sup>5</sup> [https://www.ihs.org/media/31d3dec6-79d5-48a8-bafb-1e93df1fb16f/324452632/HLDI%20Research/Bulletins/hldi\\_bulletin\\_31\\_15.pdf](https://www.ihs.org/media/31d3dec6-79d5-48a8-bafb-1e93df1fb16f/324452632/HLDI%20Research/Bulletins/hldi_bulletin_31_15.pdf)

- Voluntary cooperation by automakers promotes the proliferation of vehicle safety technologies into the U.S. fleet.
- Safety should not only be available to those who can afford it. Right now, many ADAS features are part of more expensive packages, and the used car market exposes those consumers to a higher risk just because they are choosing a used vehicle.
- We are many years away from actual fully automated cars (Level 5).
- Continuous research is necessary to ensure the safety of these systems.
- Current Federal Motor Vehicle Safety Standards and other regulations should not be repealed until there is clear, evidence based data that safety will not be compromised.

The U.S. trails other industrialized countries in addressing highway deaths. We cannot afford to ignore the carnage on our highways any longer. It is a national epidemic.

NSC appreciates this Committee's leadership on vehicle technology and safe roadway transportation. If safety for the traveling public is the ultimate goal, advanced technology provides the most promising opportunity to achieve that outcome in a short amount of time, and will go a long way toward reaching the goal of eliminating preventable deaths in our lifetime.

---

RESPONSE TO WRITTEN QUESTIONS SUBMITTED BY HON. JERRY MORAN TO  
HON. JOEL SZABAT

In 2017, there were 287 crashes attributed to illegal drug use in Kansas. Eighty-three people lost their lives in these crashes. Studies have found that marijuana use impairs a person's judgment, concentration and reaction time. Yet NHTSA found from 2007–2014 that there was a 48 percent increase in drivers testing positive for marijuana.

*Question 1.* What recommendations would you provide to address this issue both at a Federal and local level?

Answer. The Department is dedicated to raising awareness of the dangers of drug-impaired driving. We continue to support law enforcement training on drug-impaired driving, as well as training for prosecutors and judges and are conducting research on the topic of roadside testing and evaluating the accuracy of new oral fluid screening devices.

In addition, we are proactive in identifying areas to target with specific campaigns for impaired driving. Recently, the following ads have been launched in select markets:

- *If You Feel Different, You Drive Different, Drive High Get a DUI* campaign (released August 2018).
- *There is More Than One Way to be Under the Influence* (for prescription and over the counter drugs) (released 2019)
- *If You Feel Different, You Drive Different campaign* (the social norming version) (released 2019).

*Question 2.* Is it critical for local law enforcement to have the equipment needed for reliable roadside drug tests?

- Follow up. I would appreciate any insight you can provide on the development and availability of this technology to measure marijuana inebriation, and how Congress can help prevent further deaths from illegal drug use of drivers.

Answer. The Department, and specifically NHTSA, received an additional \$5M in FY 2018 and \$7M in FY 2019 to address impaired driving. The International Association of Chiefs of Police (IACP) received \$2.3 million award to increase the number of law enforcement officers who are trained as Drug Recognition Experts (DRE) and in Advanced Roadside Impaired Driving Enforcement (ARIDE). NHTSA also supports development and delivery of drug impaired driving education and technical assistance for prosecutors and judges.

Recently, NHTSA released the *Law Enforcement Phlebotomy Toolkit: A Guide to Assist Law Enforcement Agencies With Planning and Implementing a Phlebotomy Program*. The report shares best practices from agencies that have implemented phlebotomy programs.

In addition, the Department is investigating whether a behavioral or cognitive roadside test could indicate potential impairment use as well as studying the feasibility of a standardized protocol to assess the driving impairment risk of drugs. Re-

search is also evaluating the accuracy of new oral fluid screening devices that could be used by law enforcement to screen drivers for drug use in a matter of minutes.

---

RESPONSE TO WRITTEN QUESTIONS SUBMITTED BY HON. MARSHA BLACKBURN TO  
HON. JOEL SZABAT

*Question 1.* The Department of Transportation's AV 3.0 report recognized the intersection of privacy and automated vehicles. Some have argued that DOT should regulate privacy issues as it relates to automated vehicles. DO you believe that DOT is appropriately equipped to regulate privacy? Or Should DOT instead partner with other Federal entities, such as the Federal Trade Commission, to address any privacy concerns related to the automated vehicles?

Answer. U.S. DOT takes consumer privacy seriously, diligently considers the privacy implications of our safety regulations and voluntary guidance, and works closely with the Federal Trade Commission (FTC)—the primary Federal agency charged with protecting consumers' privacy and personal information—to support the protection of consumer information and provide resources relating to consumer privacy.

*Question 2.* How does DOT plan on utilizing emerging 5G networks with respect to the intersection of fully autonomous vehicles and connected infrastructure?

Answer. DOT will prepare for complementary technologies that enhance the benefits of AVs, such as communication technologies between vehicles and the surrounding environment, but will not assume universal implementation of any particular approach, including Dedicated Short Range Communications (DSRC), Connected Vehicle to Everything (C-V2X) or a future 5G technology.

---

RESPONSE TO WRITTEN QUESTIONS SUBMITTED BY HON. TODD YOUNG TO  
HON. JOEL SZABAT

I'm concerned that if we bifurcate the regulatory environment for small and large vehicles we will delay these life-saving and life-changing benefits AV technology can bring to all Americans.

*Question 1.* Considering that truck-involved crashes tend to be serious and often involve other road users—do you see a reason why development of technologies such as advanced driver-assistance systems or AV should be limited to passenger vehicles?

Answer. No, the Department does not intend to limit this technology to passenger vehicles. Advanced driver-assistance systems have the potential to save lives—and safety is always the Department's top priority. NHTSA has set FMVSS to regulate how vehicles, both passenger and motor carriers, equipment will perform when new and, in the case of more complicated safety systems (such as air bags and electronic stability control systems), require the systems to monitor their operating capability and warn drivers when there is a malfunction.

In addition, all advanced driver-assistance systems require the full and undivided attention of the drivers to assure safety.

*Question 2.* As we contemplate a legislative framework for autonomous vehicles, should vehicles above 10,000 pounds be included?

Answer. Yes. Advanced driver-assistance systems can improve and enhance safety of all vehicles and should not be limited. In addition to NHTSA's authorities, FMCSA has every authority it requires to allow for the safe and regulated introduction of automated systems in commercial motor vehicles.

According to data from the Indiana University Public Policy Institute, more Indiana drivers in deadly crashes tested positive for drugs than for being alcohol impaired.

*Question 3.* What is DOT doing to address drug-inebriated driving and how can Congress help?

Answer. The Department, and specifically NHTSA, received an additional \$5M in FY 2018 and \$7M in FY 2019 to address impaired driving. The International Association of Chiefs of Police (IACP) received \$2.3 million award to increase the number of law enforcement officers who are trained as Drug Recognition Experts (DRE) and in Advanced Roadside Impaired Driving Enforcement (ARIDE). NHTSA also supports development and delivery of drug impaired driving education and technical assistance for prosecutors and judges.

In addition, we are proactive in identifying areas to target with specific campaigns for impaired driving. Recently, the following ads have been launched in select markets:



- *If You Feel Different, You Drive Different, Drive High Get a DUI* campaign (released August 2018).
- *There is More Than One Way to be Under the Influence* (for prescription and over the counter drugs) (released 2019)
- *If You Feel Different, You Drive Different* campaign (the social norming version) (released 2019).

---

RESPONSE TO WRITTEN QUESTIONS SUBMITTED BY HON. MARIA CANTWELL TO  
HON. JOEL SZABAT

*Question 1.* While we need to prepare for the commercialization of highly automated vehicles, most new vehicles already have technologies that control braking, steering, and acceleration. Do you believe technologies like autonomous emergency braking and forward collision warning should be standard on all vehicles?

Answer. The Department, and specifically NHTSA, supports the widespread adoption of proven and mature safety technologies. Our research and those of others has identified substantive safety benefits associated with various types of advanced driver assistance systems (ADAS) available to consumers today, such as automatic emergency braking (AEB) and forward collision warning (FCW).

NHTSA continues to conduct a variety of activities related to AEB and FCW technologies. In November 2015, NHTSA added these technologies to its New Car Assessment Program, including testing for crash imminent braking and dynamic brake support system performance in vehicles beginning with model year 2018.

In March 2016, 20 automakers made a historic voluntary commitment to NHTSA and the Insurance Institute for Highway Safety to equip virtually all new passenger vehicles with low-speed AEB that includes FCW by September 1, 2022. During the reporting period, September 1, 2018, through August 31, 2019, 12 manufacturers equipped more than 75 percent of their new passenger vehicles with AEB and 20 manufacturers equipped more than 9.5 million new passenger vehicles with AEB. Manufacturers have made great strides in providing advanced safety to consumers compared to just 2 years ago, when only 30 percent of their new vehicles were equipped with AEB.

Additionally, NHTSA continues to perform research on other ADAS that help drivers avoid crashes.

*Question 2.* How is DOT approaching the human-machine interface between operators—whether that be drivers, pilots, or locomotive engineers—and the increasingly complex automated systems they are operating? What is DOT doing to ensure appropriate operator engagement, particularly in passenger vehicles, with automated technologies that perform part or all of the operating function?

Answer. No matter the mode of transportation, safety is fundamentally a human responsibility. There are open human factors questions around potential misuse, disuse, and abuse of ADAS technologies, and whether design approaches can help mitigate foreseeable safety concerns. NHTSA is very active in researching effective strategies around managing driving vigilance in the context of automated driving, and has published guidance on human-machine-interface design for SAE L2 and L3 systems.

While we need to prepare for the commercialization of highly automated vehicles, most new vehicles already have technologies that control braking, steering, and acceleration.

*Question 3.* What did DOT and NHTSA know about Uber's autonomous technologies and its testing program before the fatal crash in Tempe, Arizona? What data are you collecting about all automated technology testing to properly analyze any potential risk to the public?

Answer. The Department and NHTSA were aware of Uber's autonomous technologies and testing program in Tempe, Arizona. As the NTSB report identifies, there were multiple potential failure points at all levels that led to this outcome. We take to heart the need to learn from this horrific incident, and appreciate the ongoing investigatory work being done by NHTSA, and take very seriously the NTSB recommendations.

NHTSA employs numerous research approaches to explore the safety performance assessment of new technologies. These include: controlled track testing at our applied research labs (Vehicle Research and Test Center), naturalistic driving experiments with highly-instrumented vehicles, larger scale naturalistic studies that leverage connectivity that are being built into modern vehicles, and modeling and simulation approaches that synthesize findings across various methods.

NHTSA collects real-world crash data on ADAS technologies in both its crash record and investigation-based data systems. The collection is focused on two categories of data: vehicles that are equipped with ADAS (equipped) and vehicles that are both equipped with the ADAS and the ADAS is in use during the crash (usage). The investigation-based systems can collect specific detailed information on each technology for both equipped and use. The record-based data system relies on the information contained in the police crash reports. The police crash report data is typically collected based on the recommendation in the Model Minimum Uniform Crash Criteria.

There are challenges in determining whether a vehicle involved in a crash is equipped with ADAS and whether the ADAS is in use during a crash event. These challenges impact the quality of the real-world crash data. NHTSA would benefit from “build sheet data” for determining whether the vehicle is equipped. The only method to definitively determine usage would be through direct evaluation of the data recorded in the vehicle. While at least one manufacturer provides usage information in the event data recorder output, NHTSA investigators primarily rely on physical evidence and interviews for determining usage. In high profile investigations, NHTSA has requested the data from the manufacturer.

---

RESPONSE TO WRITTEN QUESTION SUBMITTED BY HON. JON TESTER TO  
HON. JOEL SZABAT

*Question 1.* How is the Department of Transportation currently working to ensure that individuals with disabilities are involved in the development process of autonomous vehicles in order to ensure that they will have access to this technology?

Answer. In AV 3.0, DOT recognized the potential of automation technologies to enhance individual freedom by expanding access to safe and independent mobility to people with disabilities and older Americans. The Department has focused on ensuring these stakeholders are part of our development process and their feedback is critical to our success. Over the past three years, USDOT increased investment in accessibility-related research by approximately 50 percent. These new investments demonstrate the Department’s continued commitment to innovations that enhance access and mobility for all.

On October 29, 2019, DOT hosted the Access and Mobility for All Summit to raise awareness of DOT and announced nearly \$50 million in new initiatives to expand access to transportation for people with disabilities, older adults, and individuals of low income. This includes a planned Inclusive Design Challenge, which will make up to \$5 million in cash prizes available to innovators who design solutions to enable accessible automated vehicles. DOT aims to increase availability and decrease cost of aftermarket modifiers that improve accessibility of vehicles today and spark development for future automated vehicles.

Other initiatives include:

- A planned Complete Trip Deployment solicitation, which will make up to \$40 million available to enable communities to showcase innovative business partnerships, technologies, and practices that promote independent mobility for all. “Complete Trip” means that a user can get from point A to point B seamlessly, regardless of the number of modes, transfers, and connections.
- A Notice of Funding Opportunity for FTA’s FY 2020 Mobility for All Pilot Program. The program seeks to improve mobility options and access to community services for older adults, individuals with disabilities, and people with low incomes. The \$3.5 million initiative will fund projects that enhance transportation connections to jobs, education, and health services.
- A strategic plan for the *Coordinating Council on Access and Mobility (CCAM)*, an interagency partnership to coordinate the efforts of Federal agencies funding transportation services for targeted populations. The strategic plan will help provide better transportation outcomes through the coordination of more than 130 government-wide programs.

Updates on these initiatives will be posted at [www.transportation.gov/accessibility](http://www.transportation.gov/accessibility) when available.

---

RESPONSE TO WRITTEN QUESTIONS SUBMITTED BY HON. JOHN THUNE TO  
DR. JAMES C. OWENS

*Question 1.* Dr. Owens, as I mentioned before, NHTSA has taken several actions to encourage the safe deployment of AVs, including a rulemaking proceeding to up-

date crash avoidance safety standards for areas where they are currently incompatible with AVs. When does the agency expect this rulemaking to be finalized?

Answer. NHTSA is currently evaluating the public comments and additional available information to determine next steps. NHTSA expects to announce the next steps for this rulemaking in the 2020 Spring Unified Agenda for Regulatory and De-regulatory Actions.

*Question 2.* Does NHTSA plan to issue rulemaking proceedings in the future to address additional series of safety standards, such as crashworthiness?

Answer. Yes.

Dr. Owens, you mentioned in your testimony that research will be a critical component of NHTSA and the Department's efforts to develop a regulatory framework for AVs.

*Question 3.* Can you speak to some of the research currently being conducted by the agency, and describe how you believe it will inform future motor vehicle safety standards?

Answer. NHTSA is conducting research into various aspects of Automated Driving Systems (ADSs), including:

- Challenges existing Federal Motor Vehicle Safety Standards may pose for vehicles with ADSs that have innovative interior and/or exterior designs, and whether translations or alternative test protocols can demonstrate compliance with existing standards;
- Methods and metrics for assessing safety performance of ADS-equipped vehicles, including track testing, simulation testing, and potential on-road testing components;
- Methods to assess critical subcomponents of ADS, such as Perception and Prediction;
- New tools and methods to assess crashworthiness of ADS-equipped vehicles that may offer novel seating configurations and occupant postures;

Collectively, NHTSA's research will help build a safety resume around the testing and validation of ADSs while allowing innovation for the developers.

NHTSA presented more details of its research in these topic areas at its Public Research Meetings held on November 19–20, 2019. The slides can be found in docket NHTSA–2019–0083, and recordings of sessions have been made available to the public at <https://www.nhtsa.gov/event/research-public-meeting-2019>.

---

RESPONSE TO WRITTEN QUESTIONS SUBMITTED BY HON. DEB FISCHER TO  
DR. JAMES C. OWENS

Nebraska is seeing an increase in the number of drug-related crashes. In Grand Island, Nebraska, police report that the percentage of DUIs involving drugs like marijuana has risen from 16 percent four years ago to 39 percent now. Law enforcement is doing the best it can, but there is still not a reliable roadside breathalyzer test for marijuana-use, or a uniform standard to measure marijuana-use.

*Question 1.* Aside from NHTSA's work on public awareness, what efforts is the agency taking to address drugged driving?

Answer. NHTSA continues to support law enforcement training on drug-impaired driving, as well as training for prosecutors and judges, including:

- Expanding Advanced Roadside Impaired Driving Enforcement (ARIDE) and Drug Recognition Expert (DRE) training to law enforcement and other criminal justice professionals;
- Providing a Transportation Safety Institute course to improve courtroom preparation and communication between prosecutors and toxicologists;
- Supporting the development and delivery of drug-impaired driving education and technical assistance for prosecutors and judges; and
- Supporting DWI courts—criminal justice programs that incorporate drug and alcohol treatment with the goal of reducing recidivism in high-risk DWI offenders.

NHTSA also released *Law Enforcement Phlebotomy Toolkit: A Guide to Assist Law Enforcement Agencies With Planning and Implementing a Phlebotomy Program*. This report shares best practices from agencies that have implemented phlebotomy programs.

In addition to these ongoing program efforts, NHTSA has many innovative research projects underway to advance the science on this important issue. For exam-

ple, NHTSA is investigating whether a behavioral or cognitive roadside test could indicate potential impairment use as well as studying the feasibility of a standardized protocol to assess the driving impairment risk of drugs. NHTSA is also evaluating the accuracy of new on-site oral fluid screening devices that could be used by law enforcement to screen drivers for drug use in a matter of minutes.

*Question 2.* Additionally, are there actions Congress should take that would help address drugged driving?

Answer. NHTSA appreciates Congress' support of our efforts to combat drugged driving, and we would be pleased to work with the Committee and provide technical assistance in this area.

---

RESPONSE TO WRITTEN QUESTIONS SUBMITTED BY HON. ROY BLUNT TO  
DR. JAMES C. OWENS

*Question 1.* Many stakeholders have requested that AVs meet safety standards such as a "vision test" to assure that driverless vehicles are able to effectively identify and navigate other types of roadway users like motorcyclists, pedestrians and cyclists. What is your agency's position on prescribing such standards?

Answer. NHTSA's portfolio includes research into potential assessment methods for Automated Driving Systems (ADS) subsystems, such as Perception systems for object detection and object classification. Perception testing is an emerging area that crosscuts various disciplines of engineering, and is considered one of the most challenging functions to test and validate. Research results will guide whether an objective and practical Perception test can be viable for the variety of ADS concepts under development.

*Follow up.* Would third party verification of such standards be an approach that you would recommend?

Answer. NHTSA is involved in researching safety performance methods and metrics, regardless of who conducts such testing. When methods are objective, repeatable, and reproducible, it does not matter who performs the tests. The National Traffic and Motor Vehicle Safety Act of 1966 created a self-certification regime, and manufacturers are free to use whatever method they choose to certify their vehicles to existing standards—including third party verification—but are legally required to exercise reasonable care in doing so.

*Question 2.* As AV technology and testing continues to increase, does the National Highway Traffic Safety Administration (NHTSA) support transparent reporting by manufacturers of test results so that members of the public can review the data?

Answer. NHTSA is encouraged by the release of data and scenarios by some of the Automated Driving Systems (ADS) developers. This information, along with Voluntary Safety Self Assessments, contributes to the public transparency around safety of ADSs.

*Follow up.* Specifically, would searchable data about how these new products interact with non-AV roadway users like motorcyclists, pedestrians and cyclists be an important tool for the public?

Answer. Searchable data could contribute to public transparency. However, a searchable database may be difficult to implement in a commonly formatted manner, and to maintain as products evolve continuously.

*Question 3.* Last year, the National Highway Traffic Safety Administration (NHTSA) initiated rulemaking on an AV Pilot Program, which would use existing DOT authority to create a pathway to deployment. However, there has been no movement on this program since the comments were due in 2018. What is holding up progress on this program moving forward?

Answer. NHTSA is reviewing comments and identifying potential next steps.

---

RESPONSE TO WRITTEN QUESTIONS SUBMITTED BY HON. JERRY MORAN TO  
DR. JAMES C. OWENS

In 2017, there were 287 crashes attributed to illegal drug use in Kansas. Eighty-three people lost their lives in these crashes. Studies have found that marijuana use impairs a person's judgment, concentration and reaction time. Yet NHTSA found from 2007–2014 that there was a 48 percent increase in drivers testing positive for marijuana.

*Question 1.* What recommendations would you provide to address this issue both at a Federal and local level?

Answer. NHTSA is dedicated to raising awareness of the dangers of drug-impaired driving.

We are proactive in identifying areas to target with specific campaigns for impaired driving.

Recently, NHTSA launched the following advertisements in select markets:

- If You Feel Different, You Drive Different, Drive High Get a DUI campaign (released August 2018);
- There is More Than One Way to be Under the Influence (for prescription and over the counter drugs) (released 2019); and
- If You Feel Different, You Drive Different campaign (the social norming version) (released 2019).

NHTSA continues to support local law enforcement training on drug-impaired driving, as well as training for prosecutors and judges, including:

- Expanding Advanced Roadside Impaired Driving Enforcement (ARIDE) and Drug Recognition Expert (DRE) training to law enforcement and other criminal justice professionals;
- Providing a Transportation Safety Institute course to improve courtroom preparation and communication between prosecutors and toxicologists;
- Supporting the development and delivery of drug-impaired driving education and technical assistance for prosecutors and judges; and
- Supporting DWI courts—criminal justice programs that incorporate drug and alcohol treatment with the goal of reducing recidivism in high-risk DWI offenders.

NHTSA also released *Law Enforcement Phlebotomy Toolkit: A Guide to Assist Law Enforcement Agencies With Planning and Implementing a Phlebotomy Program*. This report shares best practices from agencies that have implemented phlebotomy programs.

In addition to these ongoing program efforts, NHTSA has many innovative research projects underway to advance the science on this important issue. For example, NHTSA is investigating whether a behavioral or cognitive roadside test could indicate potential impairment use and studying the feasibility of a standardized protocol to assess the driving impairment risk of drugs. NHTSA is also evaluating the accuracy of new on-site oral fluid screening devices that could be used by law enforcement to screen drivers for drug use in a matter of minutes.

*Question 2.* Is it critical for local law enforcement to have the equipment needed for reliable roadside drug tests?

Answer. The detection of driver drug impairment typically takes place as a result of a law enforcement officer observing inappropriate driving behavior. The officer will form a suspicion of impairment based on observations, such as the appearance of the driver (*e.g.*, face flushed, speech slurred, odor of alcoholic beverages on breath), behavior of the driver, and any statements the driver has made about alcohol or drug use. The officer's observations and subsequent evidence collection are sufficient to support an impaired driving prosecution.

Recently, on-site oral fluid drug screening devices have been commercially developed and marketed to law enforcement agencies, with manufacturers claiming that they provide a relatively quick and easy indication of a driver's drug use. Devices typically screen for the presence of five to seven different drug categories.

Availability of real-time information on a driver's drug use could increase the likelihood that law enforcement officers apprehend and prosecutors charge drug-impaired drivers. However, the accuracy and reliability of these on-site screening test devices compared to laboratory-based confirmatory tests have not been clearly established. NHTSA is currently conducting research designed to provide preliminary information on the accuracy, reliability, sensitivity, and specificity of some of these devices.

*Follow up.* Can you provide any insight on the development and availability of this technology to measure marijuana inebriation, and how Congress can help prevent further deaths from illegal drug use of drivers?

Answer. While this technology has the potential to identify the presence of marijuana, quantitative analyses of marijuana levels in the human body do not correlate well to level of impairment. One of the difficulties is that the marijuana level in blood (or oral fluid) does not appear to be an accurate and reliable predictor of impairment from marijuana. Also, the drug data for fatal crashes has limitations, including lack of consistent policies and procedures across States, across jurisdictions within States, and even across testing labs within the same jurisdiction. More re-

search is needed into the relationship between marijuana levels at the time of the crash, the degree of driving impairment, and the associated risk of a fatal crash before producing an accurate estimate.

NHTSA is investigating whether a behavioral or cognitive roadside test could indicate potential impairment as well as studying the feasibility of a standardized protocol to assess the driving impairment risk of drugs. The agency is also evaluating the accuracy of new on-site oral fluid screening devices that could be used by law enforcement to screen drivers for drug use in a matter of minutes.

While research is ongoing, NHTSA has developed tools for use by law enforcement in detecting and prosecuting drivers impaired by marijuana:

- NHTSA manages of the Drug Recognition Expert (DRE) program with the International Association of Chiefs of Police and supported development of the Advanced Roadside Impaired Driving Enforcement training (ARIDE).
- Recently, NHTSA released the *Law Enforcement Phlebotomy Toolkit: A Guide to Assist Law Enforcement Agencies With Planning and Implementing a Phlebotomy Program*. The report shares best practices from agencies that have implemented phlebotomy programs.

NHTSA appreciates Congress' support of our efforts on drugged driving, and we would be pleased to work with the Committee and provide technical assistance in this area.

---

RESPONSE TO WRITTEN QUESTIONS SUBMITTED BY HON. TODD YOUNG TO  
DR. JAMES C. OWENS

I'm concerned that if we bifurcate the regulatory environment for small and large vehicles we will delay these life-saving and life-changing benefits AV technology can bring to all Americans.

*Question 1.* Considering that truck-involved crashes tend to be serious and often involve other road users—do you see a reason why development of technologies such as advanced driver-assistance systems or AV should be limited to passenger vehicles?

Answer. No. NHTSA encourages safe development and deployment of life saving technologies on all vehicle platforms.

*Follow up.* As we contemplate a legislative framework for autonomous vehicles, should vehicles above 10,000 pounds be included?

Answer. Yes. NHTSA's research to date in Automated Driving Systems (ADS) has been agnostic to vehicle class. To date, we have not identified any reason to separately consider ADS in passenger vehicles and large trucks.

According to data from the Indiana University Public Policy Institute, more Indiana drivers in deadly crashes tested positive for drugs than for being alcohol impaired.

*Question 2.* What is NHTSA doing to address drug-inebriated driving and what progress have you made?

Answer. NHTSA is dedicated to raising awareness of the dangers of drug-impaired driving.

We are proactive in identifying areas to target with specific campaigns for impaired driving.

Recently, NHTSA launched the following advertisements in select markets:

- If You Feel Different, You Drive Different, Drive High Get a DUI campaign (released August 2018);
- There is More Than One Way to be Under the Influence (for prescription and over the counter drugs) (released 2019); and
- If You Feel Different, You Drive Different campaign (the social norming version) (released 2019).

NHTSA continues to support law enforcement training on drug-impaired driving, as well as training for prosecutors and judges, including:

- Expanding Advanced Roadside Impaired Driving Enforcement (ARIDE) and Drug Recognition Expert (DRE) training to law enforcement and other criminal justice professionals;
- Providing a Transportation Safety Institute course to improve courtroom preparation and communication between prosecutors and toxicologists;
- Supporting the development and delivery of drug-impaired driving education and technical assistance for prosecutors and judges; and

- Supporting DWI courts—criminal justice programs that incorporate drug and alcohol treatment with the goal of reducing recidivism in high-risk DWI offenders.

NHTSA also released *Law Enforcement Phlebotomy Toolkit: A Guide to Assist Law Enforcement Agencies With Planning and Implementing a Phlebotomy Program*. This report shares best practices from agencies that have implemented phlebotomy programs.

In addition to these ongoing program efforts, NHTSA has many innovative research projects underway to advance the science on this important issue. For example, NHTSA is investigating whether a behavioral or cognitive roadside test could indicate potential impairment use as well as studying the feasibility of a standardized protocol to assess the driving impairment risk of drugs. NHTSA is also evaluating the accuracy of new on-site oral fluid screening devices that could be used by law enforcement to screen drivers for drug use in a matter of minutes.

*Follow up.* How can Congress help?

Answer. NHTSA appreciates Congress' support of our efforts on drugged driving, and we would be pleased to work with the Committee and provide technical assistance in this area.

*Question 3.* Can you confirm that Uber has submitted its Voluntary Safety Self-Assessment disclosure?

Answer. According to our records, Uber published its Voluntary Safety Self-Assessment on November 2, 2018. It is indexed at <https://www.nhtsa.gov/automated-driving-systems/voluntary-safety-self-assessment>.

---

RESPONSE TO WRITTEN QUESTIONS SUBMITTED BY HON. MARIA CANTWELL TO  
DR. JAMES C. OWENS

*Question 1.* While we need to prepare for the commercialization of highly automated vehicles, most new vehicles already have technologies that control braking, steering, and acceleration. Do you believe technologies like autonomous emergency braking and forward collision warning should be standard on all vehicles?

Answer. NHTSA supports the widespread adoption of proven and mature safety technologies. Our research and those of others identified substantive safety benefits associated with various types of advanced driver assistance systems (ADAS) available to consumers today, such as automatic emergency braking (AEB) and forward collision warning (FCW).

NHTSA continues to conduct a variety of activities related to AEB and FCW technologies. In November 2015, NHTSA added these technologies to its New Car Assessment Program that included testing for crash imminent braking and dynamic brake support system performance in vehicles beginning with model year 2018.

In March 2016, 20 automakers made a historic voluntary commitment to NHTSA and the Insurance Institute for Highway Safety to equip virtually all new passenger vehicles with low-speed AEB that includes forward collision warning by September 1, 2022. During the reporting period, September 1, 2018, through August 31, 2019, 12 manufacturers equipped more than 75 percent of their new passenger vehicles with AEB and 20 manufacturers equipped more than 9.5 million new passenger vehicles with AEB. Manufacturers have made great strides in providing advanced safety to consumers compared to just 2 years ago, when only 30 percent of their new vehicles were equipped with AEB.

Additionally, NHTSA continues to perform research on ADAS that help the drivers avoid crashes.

*Question 2.* What is NHTSA doing to ensure level 1 and level 2 technologies which require driver engagement, are operated in a safe way?

Answer. NHTSA has been performing human factors research across the full spectrum of driving automation systems as well as advanced driver assistance systems. The agency published two guidance documents on human factors design principles for driver-vehicle interfaces,<sup>1</sup> and for level 2 and level 3 automated driving concepts.<sup>2</sup> We continue to perform research on novel human machine interface concepts that are being introduced in the market, as well as effectiveness of attention management approaches employed by manufacturers.

---

<sup>1</sup> [https://www.nhtsa.gov/sites/nhtsa.dot.gov/files/documents/812360\\_humanfactorsdesignguidance.pdf](https://www.nhtsa.gov/sites/nhtsa.dot.gov/files/documents/812360_humanfactorsdesignguidance.pdf)

<sup>2</sup> [https://www.nhtsa.gov/sites/nhtsa.dot.gov/files/documents/13494\\_812555\\_l2l3automationhfguidance.pdf](https://www.nhtsa.gov/sites/nhtsa.dot.gov/files/documents/13494_812555_l2l3automationhfguidance.pdf)

*Question 3.* What data does NHTSA currently collect regarding the performance of level 1 and level 2 technologies, and what additional data is needed to evaluate the effectiveness and safety of these technologies?

Answer. NHTSA employs numerous research approaches to explore the safety performance assessment of new technologies. These include controlled track testing at our applied research labs (Vehicle Research and Test Center), naturalistic driving experiments with highly instrumented vehicles, larger scale naturalistic studies that leverage connectivity that are being built into modern vehicles, and modeling and simulation approaches that synthesize findings across various methods.

NHTSA collects real-world crash data on advanced driver assistance systems (ADAS) technologies in both its crash record and investigation-based data systems. The collection is focused on two categories of data: vehicles that are equipped with ADAS (equipped) and vehicles that are both equipped with the ADAS and the ADAS is in use during the crash (usage). The investigation-based systems can collect specific detailed information on each technology for both equipped and use. The record-based data system relies on the information contained in the police crash reports. The police crash report data is typically collected based on the recommendation in the Model Minimum Uniform Crash Criteria (MMUCC).

There are challenges in determining whether a vehicle involved in a crash is equipped with ADAS and whether the ADAS is in use during a crash event. These challenges impact the quality of the real-world crash data. NHTSA would benefit from “build sheet data” for determining whether the vehicle is equipped. The only method to definitively determine usage would be through direct evaluation of the data recorded in the vehicle. While at least one manufacturer provides usage information in the event data recorder output, NHTSA investigators primarily rely on physical evidence and interviews for determining usage. In high profile investigations, NHTSA has requested the data from the manufacturer.

*Question 4.* What did DOT and NHTSA know about Uber’s autonomous technologies and its testing program before the fatal crash in Tempe, Arizona? What data are you collecting about all automated technology testing to properly analyze any potential risk to the public?

Answer. NHTSA regulates and oversees the safety of motor vehicles and motor vehicle equipment. NHTSA does not regulate the testing of advanced technologies, but rather provides recommendations to State partners who may take such action. Automated Driving Systems (ADS) 2.0 provided such guidance and recommendations to States. Further, NHTSA encourages industry to develop best practices guidance for safe on-road testing of prototype systems. Society of Automotive Engineers (SAE) J3018 was established and revised to provide testing safety guidance to developers including on the selection, training, and monitoring of safety drivers.

*Question 5.* The School of Engineering at the University of Washington demonstrated in 2015 that hackers were able to remotely take control of a car. There have been several other incidents that demonstrate that cybersecurity weaknesses can be exploited and pose dangers to the driving public. How does NHTSA identify and respond to potential cyber vulnerabilities? Why hasn’t NHTSA updated its cybersecurity best practices yet and when will that be completed? What specific expertise does NHTSA currently possess to evaluate potential cyber vulnerabilities in all vehicles?

Answer. NHTSA has been very active in researching vehicle cybersecurity topics, helping and encouraging the industry to continually improve the cybersecurity posture of their vehicle platforms and also their preparedness to respond to incidents. We have encouraged and supported the establishment of the Automotive-Information Sharing and Analysis Center (ISAC), published best practices guidance, convened annual meetings in partnership with SAE International bringing together different groups to discuss hard cybersecurity challenges in the automotive world, and led by example in participating in well-established large scale cyber exercises, along with industry such as the biannual Cyberstorm exercises organized by the Department of Homeland Security. Internally, we have established working groups and incident response processes to ensure risks are appropriately and expeditiously assessed and appropriate actions are taken for the responsible parties to address potential safety risks. To support this activity, we have established an applied cybersecurity lab at Vehicle Research and Test Center to be able to independently assess the validity and risks of identified issues.

Additionally, NHTSA is working on updates to its current cybersecurity best practices.



RESPONSE TO WRITTEN QUESTIONS SUBMITTED BY HON. AMY KLOBUCHAR TO  
DR. JAMES C. OWENS

*Vehicle Recall.* As vehicles become increasingly connected through automation and mobile applications, transportation safety remains a priority for me. Recent reports have found that one in six vehicles used to transport Uber and Lyft passengers have at least one open recall and that neither app alerts passengers in these situations. In September, I led a letter to NHTSA with Senators Cantwell, Blumenthal, and Markey asking how NHTSA can work with rideshare companies to notify consumers about vehicles with open recalls.

*Question 1.* In your view, does NHTSA have adequate data regarding the use of Uber and Lyft vehicles with recalls nationwide to ensure passenger safety?

Answer. NHTSA currently does not have data regarding the use of Uber and Lyft vehicles with recalls.

*Question 2.* What can NHTSA do to work with ridesharing companies to ensure that consumers are aware if the cars they are riding in have open recalls?

Answer. While NHTSA has authority to enforce Federal laws requiring manufacturers to provide timely notice of and a free remedy for any motor vehicle defect that affects motor vehicle safety, there is no Federal law requiring vehicle owners (including rideshare vehicle owners) to complete open recall repairs or inform passengers of open recalls. NHTSA's efforts in this area to date have been focused on encouraging the ridesharing companies to work with the independent drivers who own the vehicles used to provide the services to have open recalls addressed. NHTSA recently met with Lyft and Uber executives and technical representatives to encourage these companies to incentivize drivers to check their vehicles for open recalls and to complete remedy work. Separately, NHTSA works closely with vehicle manufacturers to deliver effective recall notices and utilize other means of communication that increase recall completion rates.

In addition to our meetings with ridesharing companies, NHTSA is planning a pilot outreach program to provide on-the-spot safety recall checks for rideshare drivers and their vehicles at the U.S. Department of Transportation headquarters and other locations here in Washington, D.C. We anticipate this program will provide NHTSA with some preliminary data and understanding of how best to communicate the urgency of the issue and to motivate both ridesharing companies and vehicle owners to have open recalls completed in a timely manner. If successful, this program could be expanded to additional geographic areas and targeted at locations with high concentrations of rideshare vehicles.

These existing tools and efforts provide ridesharing companies with the means to set their own policies regarding the use of a vehicle subject to an open recall and to notify customers of the existence of an open recall on the vehicle being used to provide the ridesharing services.

---

RESPONSE TO WRITTEN QUESTIONS SUBMITTED BY HON. EDWARD MARKEY TO  
DR. JAMES C. OWENS

*Pedestrian and Bicyclist Safety.* According to a recent report by the AAA foundation, automatic emergency braking systems failed 60 percent of the time to stop a vehicle traveling at 20 miles per hour before hitting a pedestrian. When tested with child mannequins, these systems failed 89 percent of the time.

This rate of failure is unacceptable, especially when we are facing a national safety crisis on our streets for pedestrians and bicyclists. According to years of NHTSA data, pedestrian and bicyclist fatality rates are on the rise. In fact, NHTSA recently reported that more pedestrians and cyclists were killed in 2018 than in any year since 1990.

*Question 1.* How will NHTSA ensure that autonomous vehicle technology can detect, identify and respond to pedestrians, bicyclists and all other users of the road?

Answer. NHTSA has a comprehensive research program in pedestrian safety that can help facilitate the advancement of pedestrian detection. Many trim levels of modern vehicles available to consumers offer advanced driver assistance systems, including Pedestrian Automatic Emergency Braking (PAEB) systems. NHTSA has recently published its work on potential test methods and performance metrics that could help assess PAEB system performance. NHTSA plans to expand this work in 2020 to include pedalcyclists.

Vehicles that may feature higher levels of driving automation (often referred to as Automated Driving Systems or ADS, SAE levels 3–5) are still under testing and development. If ADS-equipped vehicles are to operate in environments (operational domains) that include pedestrians and bicyclists, NHTSA expects that manufactur-

ers would include object detection and response capabilities for those scenarios and that those scenarios would be validated and verified. Our active research in advanced driver assistance systems and ADS subsystems research underway consider these safety assurance needs.

*Question 2.* Are you currently testing autonomous vehicle technology with pedestrians?

Answer. NHTSA has been developing Pedestrian Automatic Emergency Braking (PAEB) test procedures and conducting tests with current model year vehicles that have advanced driver assistance systems.

*Question 3.* Are you currently testing autonomous vehicle technology with bicyclists?

Answer. NHTSA plans to initiate pedalcyclist crash avoidance testing in 2020.

*Question 4.* Are you currently testing autonomous vehicle technology with people in wheelchairs?

Answer. NHTSA is not currently performing advanced driver assistance technology testing for their ability to detect and respond to persons in wheelchairs. However, we are actively monitoring crash risk trends.

*Question 5.* Are you currently testing autonomous vehicle technology with People on scooters or using other mobility devices?

Answer. NHTSA is not currently conducting testing involving people on scooters or other mobility devices. NHTSA continues to monitor the safety issues surrounding scooters and other personal conveyance devices relative to the capabilities of current and emerging vehicle technologies.

*Question 6.* The United States Global Change Research Program issued a Climate Science Special Report as part of the Fourth National Climate Assessment, developed in conjunction with the Department of Transportation and 12 other Federal agencies. This report concluded that “human activities, especially emissions of greenhouse gases, are the dominant cause of the observed warming since the mid-20th century.”<sup>3</sup> Do you agree with this finding?

Answer. NHTSA is considering the information in the Climate Science Special Report along with a wide array of other studies and data as it prepares the Final Environmental Impact Statement for its Safer Affordable Fuel Efficient vehicles rule.

*Question 7.* The Preliminary Regulatory Impact Analysis (PRIA) for the Safer Affordable Fuel-Efficient (SAFE) Vehicles Rule for Model Year 2021–2026 Passenger Cars and Light Trucks includes divergent estimates of how much more expensive new vehicles will be under the current fuel economy standards compared to the proposed alternative of freezing standards at 2020 levels. On page 1340, the PRIA states that the “results of this analysis project that vehicle prices will be nearly \$1,900 higher under the augural CAFE standards compared to the preferred alternative that would hold stringency at MY 2020 levels in MYs 2021–2026,” while on page 100, it states that, “the analysis suggests that, compared to the proposed standards today, the previously-issued standards would increase average vehicle prices by about \$2,100.” Can you provide a mathematical explanation for the discrepancy between these figures?

Answer. NHTSA and EPA are reviewing and carefully considering all comments to the 2018 SAFE proposal as we develop the upcoming final rule.

*Question 8.* Environmental Protection Agency (EPA) staff have raised concerns over NHTSA’s air quality modeling in the PRIA, writing, “It seems peculiar that some increase while others decrease; it’s especially counter-intuitive that toxics go down while VOC goes up.”<sup>4</sup> How does NHTSA justify this conclusion, which EPA analysts have called into question?

Answer. NHTSA and EPA are reviewing and carefully considering all comments to the 2018 SAFE proposal as we develop the upcoming final rule.

*Question 9.* The Notice of Proposed Rulemaking (NPRM) for the SAFE Vehicles Rule states that freezing the standards at MY 2020 levels will result in 12,700 avoided deaths over the lifetime of the program, compared to the current standards. An EPA-revised analysis found that not only would the rollback not result in avoided deaths, it would actually cause an additional 17 fatalities per year from 2036–

<sup>3</sup> USGCRP, 2017: *Climate Science Special Report: Fourth National Climate Assessment, Volume I* [Wuebbles, D.J., D.W. Fahey, K.A. Hibbard, D.J. Dokken, B.C. Stewart, and T.K. Maycock (eds.)]. U.S. Global Change Research Program, Washington, DC, USA, 470 pp.

<sup>4</sup> *E-mail 5—E-mail from William Charmley to Chandana Achanta—June 18, 2018* [EPA-HQ-OAR-2018-0283], <https://www.regulations.gov/document?D=EPA-HQ-OAR-2018-0283-0453>.

2045—a major, alarming difference from the published estimate.<sup>5</sup> In the published NPRM, it does not appear that EPA's suggested changes to NHTSA's model were included nor that the technical concerns were remedied. Why did NHTSA not accept EPA's edits to the model?

Answer. NHTSA and EPA are reviewing and carefully considering all comments to the 2018 SAFE proposal as we develop the upcoming final rule.

---

RESPONSE TO WRITTEN QUESTION SUBMITTED BY HON. JON TESTER TO  
DR. JAMES C. OWENS

*Question.* How specifically is the National Highway Traffic Safety Administration working to address the challenges of integrating autonomous vehicles in rural areas?

Answer. NHTSA is focused on methods, metrics, and approaches that can assess the safety performance of motor vehicles and motor vehicle equipment, including automated driving functions. While we do not particularly focus on rural or urban applications, we are cognizant that safety risks and scenarios that could be encountered by Automated Driving Systems could vary based on operational design domains. If through research there are specific safety hazards and risks identified that could be unique to rollout of ADS in rural settings, we would seek methods that would take that into account.

---

RESPONSE TO WRITTEN QUESTIONS SUBMITTED BY HON. JERRY MORAN TO  
HON. ROBERT L. SUMWALT III

In 2017, there were 287 crashes attributed to illegal drug use in Kansas. Eighty-three people lost their lives in these crashes. Studies have found that marijuana use impairs a person's judgment, concentration and reaction time. Yet NHTSA found from 2007–2014 that there was a 48 percent increase in drivers testing positive for marijuana.

*Question 1.* What recommendations would you provide to address this issue both at a Federal and local level?

Answer. The NTSB has a long history of investigating accidents across all modes of transportation that involved misuse of alcohol and other drugs, and impairment remains a leading cause of crashes on our Nation's roadways. Drivers who are impaired by drugs other than alcohol present unique challenges, as well as significant opportunities to effectively address this important topic, such as improving and updating data on drugged driving, strengthening and standardizing toxicology procedures, and applying demonstrated law enforcement drug-detection techniques. The NTSB has several key recommendations in these areas.

As you point out, the National Highway Traffic Safety Administration's (NHTSA's) National Roadside Survey (NRS) found a 48-percent increase in drivers testing positive for tetrahydrocannabinol (THC) from 2007 to 2014.<sup>1</sup> Unfortunately, the NRS has not been conducted since 2014, and updated data are critical to understanding the scope of impaired driving, developing efficacious policy, and effectively distributing resources. The Federal government can play a critical role in addressing impaired driving by facilitating the collection of drugged driving data through the NRS, as well as by promoting the toxicology best practices described below.

Unlike for alcohol, no standardized drug-testing procedure exists, and there is no established limit or threshold to determine drug impairment. This results in inconsistent drug-testing practices across—and within—states. As a result of our investigations, and to address this known problem, we have recommended that Federal regulators develop a common standard of practice for drug toxicology testing, including the circumstances under which tests should be conducted, a minimum set of drugs for which to test, and cutoff values for reporting the results.<sup>2</sup>

We have recommended that states include in their highway safety plans provisions for high-visibility enforcement of impaired driving laws using passive alcohol-sensing technology during law enforcement contacts, such as routine traffic stops,

---

<sup>5</sup> *E-mail 5—E-mail from William Charmley to Chandana Achanta—June 18, 2018 [EPA-HQ-OAR-2018-0283], <https://www.regulations.gov/document?D=EPA-HQ-OAR-2018-0283-0453>.*

<sup>1</sup> US Department of Transportation, National Highway Traffic Safety Administration. "Results of the 2013–2014 National Roadside Survey of Alcohol and Drug Use by Drivers." Washington, DC: NHTSA; 2015. [https://www.nhtsa.gov/sites/nhtsa.dot.gov/files/812118-roadside\\_survey\\_2014.pdf](https://www.nhtsa.gov/sites/nhtsa.dot.gov/files/812118-roadside_survey_2014.pdf)

<sup>2</sup> National Transportation Safety Board, Safety Recommendation H-12-33.

saturation patrols, sobriety checkpoints, and accident scene responses.<sup>3</sup> Law enforcement efforts specific to detecting drugs are also critical.

Additional related safety recommendations are attached.

It is critical for local law enforcement to have the equipment needed for reliable roadside drug tests.

*Question 2.* I would appreciate any insight you can provide on the development and availability of this technology to measure marijuana inebriation, and how Congress can help prevent further deaths from illegal drug use of drivers.

Answer. Detecting drugs in drivers is critical to both enforcement and deterrence. Currently, when a driver is stopped by law enforcement, it is up to the officer to determine if the individual is impaired. Evaluating the impact of drugs on a driver's performance is challenging because many drugs impair individuals differently than alcohol, and there are hundreds of different drugs—illicit and legal—available to users. As a result, unlike alcohol where a toxicology parameter (such as blood alcohol level) may be used to infer a driver's impairment, testing positive for other drugs does not necessarily mean an individual was actively impaired by that drug at the time of driving. Thus, effectively identifying drug-impaired driving requires demonstrating drug use through roadside and laboratory toxicology testing that documents driver substance use and law enforcement observations that indicate actual driver impairment.

Roadside oral fluid drug-testing devices may be an important early investigative step in detecting drug presence in drivers. As opposed to waiting lengthy periods of time for laboratory testing, roadside oral fluid devices can provide quick, qualitative (above or below certain drug threshold) results for a number of common drugs. The accuracy of this technology is rapidly improving and is supported by emerging research. After examining available roadside testing equipment, we concluded that oral fluid drug-screening devices can improve law enforcement officers' ability to detect drug-impaired drivers. Several oral fluid drug-screening devices are now available; however, their overall performance varies based on the type of device and drug classes for which they test. We have recommended that NHTSA develop and disseminate best practices, identify model specifications, and create a conforming products list for oral fluid drug-screening devices.<sup>4</sup>

Roadside oral fluid and laboratory drug testing may provide critical information about a driver's history of drug use, but not direct evidence of impairment; therefore, it should be supplemented with officer documentation and impairment evaluations. Although standardized field sobriety tests were designed to detect alcohol impairment, additional law enforcement training, such as Advanced Roadside Impaired Driving Enforcement (ARIDE) training and the Drug Evaluation and Classification (DEC) Program, is specifically designed to help officers recognize impairment by drugs other than alcohol. Law enforcement officers trained in the DEC Program as drug recognition experts can administer a standardized, postarrest procedure to determine if a suspect is impaired by one or more categories of drugs. Both ARIDE training and the DEC Program, when used in conjunction with roadside oral fluid testing and a standard of practice for drug toxicology testing, are critical to detecting drug-impaired drivers.

---

RESPONSE TO WRITTEN QUESTION SUBMITTED BY HON. ROY BLUNT TO  
HON. ROBERT L. SUMWALT III

*Question 1.* As AV technology and testing continues to increase, does the National Transportation Safety Board (NTSB) support transparent reporting by manufacturers of test results so that members of the public can review the data?

Answer. The NTSB believes that additional data needs to be collected and reported to ensure safe automated vehicle (AV) development and deployment. Based on our investigation of a crash involving a vehicle operating in semiautonomous mode in Williston, Florida, we have called on the U.S. Department of Transportation (DOT) and its agencies to define recorded AV data parameters and to require manufacturers to report AV crash data.<sup>5</sup>

Further, the building blocks of AVs—collision avoidance technologies, such as forward collision warning and automatic emergency braking systems—are available to improve safety *today*; however, consumers need to be informed about their availability and their capabilities. Accordingly, we have recommended that vehicle manu-

<sup>3</sup>National Transportation Safety Board, Safety Recommendation H-13-6.

<sup>4</sup>National Transportation Safety Board, Safety Recommendation H-18-56.

<sup>5</sup>National Transportation Safety Board, Safety Recommendations H-17-37, H-17-39, and H-17-40.

facturers install these systems as standard equipment in all new vehicles, and that the National Highway Traffic Safety Administration (NHTSA) incorporate them into its New Car Assessment Program (NCAP) rating system.<sup>6</sup>

We believe the NCAP is an excellent way to convey test results, specifically regarding collision avoidance system performance, to the public. Unfortunately, the current NCAP only reports on the presence of these systems, not their performance.

*Question 2.* Specifically, would searchable data about how these new products interact with non-AV roadway users like motorcyclists, pedestrians and cyclists be an important tool for the public?

Answer. To address the increase in the number of vulnerable road user fatalities across the nation, the NTSB recently published two special investigation reports: one pertaining to pedestrian safety and the other examining bicyclist safety. We recommended that NHTSA develop performance tests to evaluate automatic pedestrian safety systems and a car's ability to avoid crashes with bicycles, and to incorporate such systems into the NCAP. Again, we believe consumers need to be more aware of the availability of these systems and their performance capabilities and limitations.<sup>7</sup>

---

RESPONSE TO WRITTEN QUESTION SUBMITTED BY HON. TODD YOUNG TO  
HON. ROBERT L. SUMWALT III

I'm concerned that if we bifurcate the regulatory environment for small and large vehicles we will delay these life-saving and life-changing benefits AV technology can bring to all Americans.

*Question 1.* Considering that truck-involved crashes tend to be serious and often involve other road users—do you see a reason why development of technologies such as advanced driver-assistance systems or AV should be limited to passenger vehicles?

Answer. Automate vehicles (AVs) and the building blocks that go into them, such as driver-assistance systems, have great potential to improve safety for all road users. Many of the initial recommendations we issued regarding collision avoidance systems focused on their use in commercial vehicles. Nearly 20 years ago, we published a special investigation report, *Vehicle-and Infrastructure-Based Technology for the Prevention of Rear-End Collisions*, in which we recommended that the National Highway Traffic Safety Administration (NHTSA) complete a rulemaking on adaptive cruise control and collision warning system performance standards for new commercial vehicles.<sup>8</sup> In 2015, due to NHTSA's inaction, we closed this recommendation unacceptably. We have since recommended that NHTSA develop performance standards and protocols to assess forward collision avoidance systems in commercial vehicles.<sup>9</sup> This recommendation is currently open, but NHTSA has conducted research and, thus far, provided an acceptable response. In 2018, as a result of several school bus crash investigations, we issued a similar recommendation that all new school buses be equipped with collision avoidance systems and automatic emergency braking technologies.<sup>10</sup>

Although we have recommended and advocated for these advanced systems on both passenger and commercial vehicles, and despite the technologies having been proven viable, progress toward fleetwide implementation of these systems has been disappointingly slow.

*Question 2.* As we contemplate a legislative framework for autonomous vehicles, should vehicles above 10,000 pounds be included?

Answer. Yes. We have investigated many crashes in which a commercial vehicle struck the rear vehicle in a queue of suddenly slowed or stopped traffic. This is a tragically common crash scenario that, because of the striking vehicle's weight and average highway speed, is nearly always fatal. We continue to recommend and advocate for advanced technologies that can avoid or mitigate crashes. Safety systems that can avoid a crash in the last moments are critical, regardless of if they are employed on a passenger or commercial vehicle, or a vehicle driven by a human or an automated system.

<sup>6</sup>National Transportation Safety Board, Safety Recommendations H-15-6, H-15-7, H-15-8, and H-15-9.

<sup>7</sup>National Transportation Safety Board, Safety Recommendations H-18-42, H-18-43, and H-19-36.

<sup>8</sup>National Transportation Safety Board, Safety Recommendation H-01-6.

<sup>9</sup>National Transportation Safety Board, Safety Recommendation H-15-5.

<sup>10</sup>National Transportation Safety Board, Safety Recommendation H-18-8.

According to data from the Indiana University Public Policy Institute, more Indiana drivers in deadly crashes tested positive for drugs than for being alcohol impaired.

*Question 3.* What is NTSB doing to address drug-inebriated driving and how can Congress help?

Answer. The NTSB has a long history of investigating accidents across all modes of transportation that involved misuse of alcohol and other drugs, and impairment remains a leading cause of crashes on our Nation's roadways. Drivers who are impaired by drugs other than alcohol present unique challenges, as well as significant opportunities to effectively address this important topic, such as improving and updating data on drugged driving, strengthening and standardizing toxicology procedures, and applying demonstrated law enforcement drug-detection techniques. The NTSB has several key recommendations in these areas.

NHTSA's National Roadside Survey (NRS) found a 48-percent increase in drivers testing positive for tetrahydrocannabinol from 2007 to 2014.<sup>11</sup> Unfortunately, the NRS has not been conducted since 2014, and updated data are critical to understanding the scope of impaired driving, developing efficacious policy, and effectively distributing resources. The Federal government can play a critical role in addressing impaired driving by facilitating the collection of drugged driving data through the NRS, as well as by promoting the toxicology best practices described below.

Unlike for alcohol, no standardized drug-testing procedure exists, and there is no established limit or threshold to determine drug impairment. This results in inconsistent drug-testing practices across—and within—states. As a result of our investigations, and to address this known problem, we have recommended that Federal regulators develop a common standard of practice for drug toxicology testing, including the circumstances under which tests should be conducted, a minimum set of drugs for which to test, and cutoff values for reporting the results.<sup>12</sup>

RESPONSE TO WRITTEN QUESTION SUBMITTED BY HON. MARIA CANTWELL TO  
HON. ROBERT L. SUMWALT III

*Question.* The National Transportation Safety Board has done a lot of work on human factors. What are the most important issues that Congress and the Department of Transportation should focus on to safely deploy automated technologies?

Answer. Automation technologies have the potential to improve transportation safety; yet, history has shown that introducing automation can lead to new safety challenges. Many automated systems rely on human operators to remain vigilant and monitor system performance; however, human factors research has shown that humans are susceptible to error when performing tasks that require sustained vigilance, especially when responding to an unexpected situation. Recent high-profile events in highway and aviation have brought these issues to light, and the NTSB has responded with specific recommendations to the U.S. Department of Transportation (DOT) and its modal administrations to foster the safe development and deployment of automated technologies in transportation.

In 2017, we issued a report on the first fatal crash involving a car operating in automated mode.<sup>1</sup> We found that factors such as driver overreliance on vehicle automation and vehicle design permitted prolonged disengagement from the driving task. Our recommendations to the National Highway Traffic Safety Administration (NHTSA), the DOT, and auto manufacturers focused on incorporating system safeguards that limit the use of automated vehicles (AVs) to the conditions for which they were designed. We also called on NHTSA and the DOT to define recorded AV data parameters and to require manufacturers to report AV crash data.<sup>2</sup>

Our most recent recommendations stem from our investigation of a collision between a car controlled by a developmental automated driving system and a pedestrian.<sup>3</sup> Contributing to that crash was ineffective oversight of the vehicle's operators

<sup>11</sup>US Department of Transportation, National Highway Traffic Safety Administration. "Results of the 2013–2014 National Roadside Survey of Alcohol and Drug Use by Drivers." Washington, DC: NHTSA; 2015. [https://www.nhtsa.gov/sites/nhtsa.dot.gov/files/812118-roadside\\_survey\\_2014.pdf](https://www.nhtsa.gov/sites/nhtsa.dot.gov/files/812118-roadside_survey_2014.pdf)

<sup>12</sup>National Transportation Safety Board, Safety Recommendation H–12–33.

<sup>1</sup>National Transportation Safety Board. 2017. *Collision Between a Car Operating With Automated Vehicle Control Systems and a Tractor-Semitrailer Truck Near Williston, Florida, May 7, 2016*. NTSB/HAR–17/02.

<sup>2</sup>National Transportation Safety Board, Safety Recommendations H–17–37, H–17–38, H–17–39, and H–17–40.

<sup>3</sup>National Transportation Safety Board. 2019. *Collision Between Vehicle Controlled by Developmental Automated Driving System and Pedestrian*. NTSB/HAR–19/03.

and of the AV testing, as well as a lack of adequate mechanisms to address operators' automation complacency. We recommended that NHTSA require those who wish to test automated driving systems to submit a safety self-assessment report and to establish a process to evaluate such reports to determine if they include appropriate safeguards, such as vehicle operator engagement monitoring.<sup>4</sup>

RESPONSE TO WRITTEN QUESTION SUBMITTED BY HON. AMY KLOBUCHAR TO HON. ROBERT L. SUMWALT III

*Question.* This week, NTSB released a report showing that distracted driving played a role in the fatal crash of an autonomous test vehicle that struck and killed a pedestrian last year. In your view, what should both regulators and industry be doing in an effort to prevent more of these types of tragic accidents?

*Answer.* The final report of our investigation of the Tempe, Arizona, crash was published on December 11, 2019. Based on this investigation, we recommended that the National Highway Traffic Safety Administration (NHTSA) require and evaluate the submission of the currently voluntary safety self-assessment report. We also recommended that states establish an application process for autonomous vehicle testing, and that industry implement safety management systems.<sup>5</sup> Ultimately, operators and regulators need to ensure sufficient risk management and establish countermeasures to prevent crashes and operator inattentiveness within the approved testing parameters.

While many efforts focus on higher levels of automation, we believe that partial automated systems, or SAE Level 2 systems, give us key information; therefore, we recommended that NHTSA, the U.S. Department of Transportation (DOT), and auto manufacturers incorporate system safeguards that limit the use of AVs to the conditions for which they were designed. We also called on NHTSA and the DOT to define recorded AV data parameters and to require manufacturers to report AV crash data.<sup>6</sup> Implementing these recommendations will reduce the risk of these crashes while automated systems continue to be developed and tested.

**National Transportation Safety Board—Recommendation Subjects**

Overall Status: All Open      Addressee: NHTSA

Recommendation #	Overall Status	Date Closed	Subject
H-00-001	OUA		TO THE NATIONAL HIGHWAY TRAFFIC SAFETY ADMINISTRATION: Revise the Federal Motor Vehicle Safety Standards to require that all motorcoaches be equipped with emergency lighting fixtures that are outfitted with a self-contained independent power source.
H-00-002	OUA		TO THE NATIONAL HIGHWAY TRAFFIC SAFETY ADMINISTRATION: Revise the Federal Motor Vehicle Safety standards to require the use of interior luminescent or exterior retroreflective material or both to mark all emergency exits in all motorcoaches.
H-00-028	OUA		TO NATIONAL HIGHWAY TRAFFIC SAFETY ADMINISTRATION: Modify the Federal Motor Vehicle Safety Standards to prohibit protruding door handles or latching mechanisms on emergency exit doors.
H-01-040	OUA		TO THE NATIONAL HIGHWAY TRAFFIC SAFETY ADMINISTRATION: Develop and incorporate into the Federal Motor Vehicle Safety Standards performance standards for school buses that address passenger protection for sidewalls, sidewall components, and seat frames.
H-01-041	OUA		TO THE NATIONAL HIGHWAY TRAFFIC SAFETY ADMINISTRATION: Evaluate the feasibility of incorporating automatic crash notification systems on school buses and, if feasible, proceed with system development.
H-09-022	OUA		TO THE NATIONAL HIGHWAY TRAFFIC SAFETY ADMINISTRATION: Require all new motor vehicles weighing over 10,000 pounds to be equipped with direct tire pressure monitoring systems to inform drivers of the actual tire pressures on their vehicles

<sup>4</sup>National Transportation Safety Board Safety Recommendations H-19-47 and H-19-48.

<sup>5</sup>National Transportation Safety Board, Safety Recommendations H-19-47, H-19-48, H-19-49, H-19-50, H-19-51, and H-19-52.

<sup>6</sup>National Transportation Safety Board, Safety Recommendations H-17-37, H-17-38, H-17-39, and H-17-40.

Overall Status: All Open

Addressee: NHTSA—Continued

Recommendation #	Overall Status	Date Closed	Subject
H-10-001	OUA		TO THE NATIONAL HIGHWAY TRAFFIC SAFETY ADMINISTRATION: Require new commercial motor vehicles with a gross vehicle weight rating above 10,000 pounds to be equipped with lane departure warning systems.
H-10-003	OUA		TO THE NATIONAL HIGHWAY TRAFFIC SAFETY ADMINISTRATION: In your rulemaking to improve motorcoach roof strength, occupant protection, and window glazing standards, include all buses with a gross vehicle weight rating above 10,000 pounds, other than school buses.
H-10-004	OAA		TO THE NATIONAL HIGHWAY TRAFFIC SAFETY ADMINISTRATION: Develop performance standards for all newly manufactured buses with a gross vehicle weight rating above 10,000 pounds to require that overhead luggage racks are constructed and installed to prevent head and neck injuries and remain anchored during an accident sequence. (This recommendation supersedes Safety Recommendations H-09-23 and -24.)
H-10-012	OUA		TO THE NATIONAL HIGHWAY TRAFFIC SAFETY ADMINISTRATION: To improve highway vehicle crash compatibility, develop performance standards for front underride protection systems for trucks with gross vehicle weight ratings over 10,000 pounds. [This recommendation supersedes Safety Recommendation H-06-16]
H-10-013	OUA		TO THE NATIONAL HIGHWAY TRAFFIC SAFETY ADMINISTRATION: After establishing performance standards for front underride protection systems for trucks with gross vehicle weight ratings over 10,000 pounds, require that all such newly manufactured trucks be equipped with front underride protection systems meeting the performance standards.
H-10-014	OUA		TO THE NATIONAL HIGHWAY TRAFFIC SAFETY ADMINISTRATION: Develop and implement minimum performance standards for event data recorders for trucks with gross vehicle weight ratings over 10,000 pounds that address, at a minimum, the following elements: data parameters to be recorded; data sampling rates; duration of recorded event; standardized or universal data imaging interface; data storage format; and device and data survivability for crush, impact, fluid exposure and immersion, and thermal exposure. The standards should also require that the event data recorder be capable of capturing and preserving data in the case of a power interruption or loss, and of accommodating future requirements and technological advances, such as flashable and/or reprogrammable operating system software and/or firmware updates.
H-10-015	OUA		TO THE NATIONAL HIGHWAY TRAFFIC SAFETY ADMINISTRATION: After establishing performance standards for event data recorders for trucks with gross vehicle weight ratings over 10,000 pounds, require that all such vehicles be equipped with event data recorders meeting the standards.
H-11-007	OUA		TO THE NATIONAL HIGHWAY TRAFFIC SAFETY ADMINISTRATION: Develop stability control system performance standards for all commercial motor vehicles and buses with a gross vehicle weight rating greater than 10,000 pounds, regardless of whether the vehicles are equipped with a hydraulic or a pneumatic brake system. This recommendation supersedes Safety Recommendation H-10-5.
H-11-008	OUA		TO THE NATIONAL HIGHWAY TRAFFIC SAFETY ADMINISTRATION: Once the performance standards in Safety Recommendation H-11-7 have been developed, require the installation of stability control systems on all newly manufactured commercial vehicles with a gross vehicle weight rating greater than 10,000 pounds. This recommendation supersedes Safety Recommendation H-10-6.
H-11-009	OUA		TO THE NATIONAL HIGHWAY TRAFFIC SAFETY ADMINISTRATION: Establish comprehensive minimum rollover performance standards, based on the least stable condition operated, for all newly manufactured cargo tank motor vehicles with a gross vehicle weight rating greater than 10,000 pounds.
H-11-010	OUA		TO THE NATIONAL HIGHWAY TRAFFIC SAFETY ADMINISTRATION: Once the performance standards in Safety Recommendation H-11-9 have been developed, require that all newly manufactured cargo tank motor vehicles with a gross vehicle weight rating greater than 10,000 pounds comply with the performance standards.



Overall Status: All Open

Addressee: NHTSA—Continued

Recommendation #	Overall Status	Date Closed	Subject
H-11-011	OUA		TO THE NATIONAL HIGHWAY TRAFFIC SAFETY ADMINISTRATION: Evaluate the effect of emergency maneuvers on the sloshing and surging of bulk liquids that have various densities over a range of partially filled levels in a U.S. Department of Transportation specification cargo tank.
H-11-012			If the results of Safety Recommendation H-11-11 warrant action, establish and implement performance standards for mitigating the sloshing and surging of bulk liquids in all newly manufactured cargo tank motor vehicles with a gross vehicle weight rating greater than 10,000 pounds.
H-11-036	OUA		TO THE NATIONAL HIGHWAY TRAFFIC SAFETY ADMINISTRATION: Modify Federal Motor Vehicle Safety Standard 217 to require that all emergency exits on school buses be easily opened and remain open during an emergency evacuation.
H-11-037	OUA		TO THE NATIONAL HIGHWAY TRAFFIC SAFETY ADMINISTRATION: Modify Federal Motor Vehicle Safety Standard 217 or the corresponding laboratory test procedure to eliminate the potential for objects such as latch plates to protrude into the emergency exit window opening space even when that protrusion still allows the exit window to meet the opening size requirements.
H-11-038	OUA		TO THE NATIONAL HIGHWAY TRAFFIC SAFETY ADMINISTRATION: To cover the interim period until Federal Motor Vehicle Safety Standard 217 is modified as specified in Safety Recommendations H-11-36 and 37, provide the states with guidance on how to minimize potential evacuation delays that could be caused by protruding latch mechanisms on emergency exit windows and by exit windows that require additional manual assistance to remain open during egress.
H-12-020	OUA		TO THE NATIONAL HIGHWAY TRAFFIC SAFETY ADMINISTRATION: Develop performance standards for advanced speed-limiting technology, such as variable speed limiters and intelligent speed adaptation devices, for heavy vehicles, including trucks, buses, and motorcoaches.
H-12-021	OUA		TO THE NATIONAL HIGHWAY TRAFFIC SAFETY ADMINISTRATION: After establishing performance standards for advanced speed-limiting technology for heavy commercial vehicles, require that all newly manufactured heavy vehicles be equipped with such devices.
H-12-022	OUA		TO THE NATIONAL HIGHWAY TRAFFIC SAFETY ADMINISTRATION: Evaluate the effects of seat spacing and armrests as factors for potential occupant injury, and if safer spacing or armrest configurations are identified, develop and implement appropriate guidelines.
H-12-032	OUA		TO THE NATIONAL HIGHWAY TRAFFIC SAFETY ADMINISTRATION: Develop and disseminate to the 50 states, the Commonwealth of Puerto Rico, and the District of Columbia blood alcohol concentration testing and reporting guidelines based on the 2012 report State Blood Alcohol Concentration Testing and Reporting for Drivers Involved in Fatal Crashes: Current Practices, Results, and Strategies, 1997-2009.
1H-12-033	OAA		TO THE NATIONAL HIGHWAY TRAFFIC SAFETY ADMINISTRATION: Develop and disseminate to appropriate state officials a common standard of practice for drug toxicology testing, including (1) the circumstances under which tests should be conducted, (2) a minimum set of drugs for which to test, and (3) cut-off values for reporting the results.
H-12-043			Work with the Automotive Coalition for Traffic Safety, Inc., to accelerate widespread implementation of Driver Alcohol Detection System for Safety (DADSS) technology by (1) defining usability testing that will guide driver interface design and (2) implementing a communication program that will direct driver education and promote public acceptance.
H-12-058	OUA		TO THE NATIONAL HIGHWAY TRAFFIC SAFETY ADMINISTRATION: Develop minimum performance standards for onboard brake stroke monitoring systems for all air-braked commercial vehicles.
H-12-059	OUA		TO THE NATIONAL HIGHWAY TRAFFIC SAFETY ADMINISTRATION: Once the performance standards in Safety Recommendation H-12-58 have been developed, require that all newly manufactured air-braked commercial vehicles be equipped with onboard brake stroke monitoring systems.

Overall Status: All Open

Addressee: NHTSA—Continued

Recommendation #	Overall Status	Date Closed	Subject
H-13-001	OAA		TO THE NATIONAL HIGHWAY TRAFFIC SAFETY ADMINISTRATION: Seek legislative authority to award incentive grants for states to establish a per se blood alcohol concentration (BAC) limit of 0.05 or lower for all drivers who are not already required to adhere to lower BAC limits.
H-13-011	OUA		TO THE NATIONAL HIGHWAY TRAFFIC SAFETY ADMINISTRATION: Develop performance standards for visibility enhancement systems to compensate for blind spots in order to improve the ability of drivers of single-unit trucks with gross vehicle weight ratings over 10,000 pounds to detect vulnerable road users, including pedestrians and cyclists, in their travel paths.
H-13-012	OUA		TO THE NATIONAL HIGHWAY TRAFFIC SAFETY ADMINISTRATION: Once the performance standards requested in H-13-11 have been developed, require newly manufactured single-unit trucks with gross vehicle weight ratings over 10,000 pounds to be equipped with visibility enhancement systems meeting the performance standards.
H-13-013	OUA		TO THE NATIONAL HIGHWAY TRAFFIC SAFETY ADMINISTRATION: Develop performance standards for side underride protection systems for single-unit trucks with gross vehicle weight ratings over 10,000 pounds.
H-13-014	OUA		TO THE NATIONAL HIGHWAY TRAFFIC SAFETY ADMINISTRATION: Once the performance standards requested in H-13-13 have been developed, require newly manufactured single-unit trucks with gross vehicle weight ratings over 10,000 pounds to be equipped with side underride protection systems meeting the performance standards.
H-13-015	OUA		TO THE NATIONAL HIGHWAY TRAFFIC SAFETY ADMINISTRATION: Develop performance standards for rear underride protection systems for single-unit trucks with gross vehicle weight ratings over 10,000 pounds.
H-13-016	OUA		TO THE NATIONAL HIGHWAY TRAFFIC SAFETY ADMINISTRATION: Once the performance standards requested in H-13-15 have been developed, require newly manufactured single-unit trucks with gross vehicle weight ratings over 10,000 pounds to be equipped with rear underride protection systems meeting the performance standards.
H-13-017			Require conspicuity treatments on the sides and rears of newly manufactured single-unit trucks with gross vehicle weight ratings over 10,000 pounds consistent with the requirements for such treatments on truck-tractors and trailers specified in 49 CFR Part 571.108 (Federal Motor Vehicle Safety Standards: Lamps, Reflective Devices, and Associated Equipment).
H-13-018	OUA		TO THE NATIONAL HIGHWAY TRAFFIC SAFETY ADMINISTRATION: Develop and implement a plan for using vehicle identification numbers and other variables, such as cargo type or trailers, to improve the coding and classification of large commercial vehicles in the Fatality Analysis Reporting System and the National Automotive Sampling System.
H-13-030	OUA		TO THE NATIONAL HIGHWAY TRAFFIC SAFETY ADMINISTRATION: Develop minimum performance standards for connected vehicle technology for all highway vehicles.
H-13-031	OUA		TO THE NATIONAL HIGHWAY TRAFFIC SAFETY ADMINISTRATION: Once minimum performance standards for connected vehicle technology are developed, require this technology to be installed on all newly manufactured highway vehicles.
H-14-001	OUA		TO THE NATIONAL HIGHWAY TRAFFIC SAFETY ADMINISTRATION: Require that newly manufactured truck-tractors with gross vehicle weight ratings over 26,000 pounds be equipped with visibility enhancement systems to improve the ability of drivers of tractor-trailers to detect passenger vehicles and vulnerable road users, including pedestrians, cyclists, and motorcyclists.
H-14-002	OAA		TO THE NATIONAL HIGHWAY TRAFFIC SAFETY ADMINISTRATION: Require that newly manufactured trailers with gross vehicle weight ratings over 10,000 pounds be equipped with side underride protection systems that will reduce underride and injuries to passenger vehicle occupants.

Overall Status: All Open

Addressee: NHTSA—Continued

Recommendation #	Overall Status	Date Closed	Subject
H-14-003	OAA		TO THE NATIONAL HIGHWAY TRAFFIC SAFETY ADMINISTRATION: Require that newly manufactured truck-tractors with gross vehicle weight ratings over 26,000 pounds be equipped with side underride protection systems that will reduce underride and injuries to passenger vehicle occupants.
H-14-004	OAA		TO THE NATIONAL HIGHWAY TRAFFIC SAFETY ADMINISTRATION: Revise requirements for rear underride protection systems for newly manufactured trailers with gross vehicle weight ratings over 10,000 pounds to ensure that they provide adequate protection of passenger vehicle occupants from fatalities and serious injuries resulting from fullwidth and offset trailer rear impacts.
H-14-005	OAA		TO THE NATIONAL HIGHWAY TRAFFIC SAFETY ADMINISTRATION: Add trailer vehicle identification number and trailer model year to the Fatality Analysis Reporting System database for trailers with gross vehicle weight ratings over 10,000 pounds.
H-14-006	OAA		TO THE NATIONAL HIGHWAY TRAFFIC SAFETY ADMINISTRATION: Work with the Model Minimum Uniform Crash Criteria expert panel to modify the data element titled "Motor Vehicle License Number" to include the trailer license plate number in the next edition of the Model Minimum Uniform Crash Criteria Guideline.
H-14-007	OAA		TO THE NATIONAL HIGHWAY TRAFFIC SAFETY ADMINISTRATION: Work with the Model Minimum Uniform Crash Criteria expert panel to modify the data element titled "Vehicle Identification Number" to include the trailer vehicle identification number in the next edition of the Model Minimum Uniform Crash Criteria Guideline.
H-15-004	OAA		TO THE NATIONAL HIGHWAY TRAFFIC SAFETY ADMINISTRATION: Develop and apply testing protocols to assess the performance of forward collision avoidance systems in passenger vehicles at various velocities, including high speed and high velocity-differential.
H-15-005	OAA		TO THE NATIONAL HIGHWAY TRAFFIC SAFETY ADMINISTRATION: Complete, as soon as possible, the development and application of performance standards and protocols for the assessment of forward collision avoidance systems in commercial vehicles. (Safety Recommendation H-15-005 supersedes Safety Recommendation H-01006)
H-15-006	OAA		TO THE NATIONAL HIGHWAY TRAFFIC SAFETY ADMINISTRATION: Expand the New Car Assessment Program 5-star rating system to include a scale that rates the performance of forward collision avoidance systems.
H-15-007	OAA		TO THE NATIONAL HIGHWAY TRAFFIC SAFETY ADMINISTRATION: Once the rating scale, described in Safety Recommendation H-15-6, is established, include the ratings of forward collision avoidance systems on the vehicle Monroney labels.
H-15-010	OAA		TO THE NATIONAL HIGHWAY TRAFFIC SAFETY ADMINISTRATION: Develop requirements addressing the minimum aisle width for safe evacuation from all buses, including those with moveable seats.
H-15-012	OAA		TO THE NATIONAL HIGHWAY TRAFFIC SAFETY ADMINISTRATION: Revise Federal Motor Vehicle Safety Standard302 to adopt the more rigorous performance standards for interior flammability and smoke emissions characteristics already in use throughout the U.S. Department of Transportation for commercial aviation and rail passenger transportation.
H-15-013	OAA		TO THE NATIONAL HIGHWAY TRAFFIC SAFETY ADMINISTRATION: Require new motorcoach and bus designs to include a secondary door for use as an additional emergency exit.
H-15-017	OAA		TO THE NATIONAL HIGHWAY TRAFFIC SAFETY ADMINISTRATION: Require that modifications to limo van vehicles (1) retain a full-sized exit on at least one side of the vehicle's passenger compartment, and (2) have at least one other exit located on the front, back, or roof of the passenger compartment.
H-15-027	OAA		TO THE NATIONAL HIGHWAY TRAFFIC SAFETY ADMINISTRATION: Seek authority to require all tire dealers to register tires at the point of sale, and then require them to do so.
H-15-028	OAA		Develop voluntary standards, in consultation with tire industry leaders, for a computerized method of capturing, storing, and uploading tire registration information at the point of sale.

Overall Status: All Open

Addressee: NHTSA—Continued

Recommendation #	Overall Status	Date Closed	Subject
H-15-029	OAA		TO THE NATIONAL HIGHWAY TRAFFIC SAFETY ADMINISTRATION: Include fields on the tire registration form for the purchaser's e-mail address, telephone number, and vehicle identification number to assist manufacturers in locating and notifying owners of recalled tires.
H-15-030	OUA		TO THE NATIONAL HIGHWAY TRAFFIC SAFETY ADMINISTRATION: Require tire manufacturers to include the complete tire identification number on both the inboard and outboard sidewalls of a tire.
H-15-031	OAA		TO THE NATIONAL HIGHWAY TRAFFIC SAFETY ADMINISTRATION: Require tire manufacturers to put the safety recall information for their tires on their websites in a format that is searchable by tire identification number as well as by brand and model; if necessary, seek legislative authority to implement this recommendation.
H-15-032	OAA		TO THE NATIONAL HIGHWAY TRAFFIC SAFETY ADMINISTRATION: Modify the tire recall search feature on your website to allow users to search for recalls by tire identification number as well as by brand and model.
H-15-033	OAA		TO THE NATIONAL HIGHWAY TRAFFIC SAFETY ADMINISTRATION: Determine the level of crash risk associated with tire aging since the implementation of Federal Motor Vehicle Safety Standard Nos. 138 and 139; if, based on this determination, it appears that the aging-related risk should be mitigated, develop and implement a plan to promote the tire aging test protocol to reduce the risk.
H-15-034	OUA		TO THE NATIONAL HIGHWAY TRAFFIC SAFETY ADMINISTRATION: Develop a consensus document with input from the automotive industry, the tire industry, and safety advocacy groups that addresses tire aging and service life and that also includes best practices for those consumers whose tires are most at risk of experiencing an aging-related failure.
H-15-035	OAA		TO THE NATIONAL HIGHWAY TRAFFIC SAFETY ADMINISTRATION: Develop, in consultation with automotive and tire industry representatives, a tire safety action plan to reduce or mitigate tire-related crashes by promoting technological innovation and adapting regulations as necessary.
H-15-040	OAA		TO THE NATIONAL HIGHWAY TRAFFIC SAFETY ADMINISTRATION: Develop, and require compliance with, a side-impact protection standard for all newly manufactured medium-size buses, regardless of weight.
H-16-018	OUA		TO THE NATIONAL HIGHWAY TRAFFIC SAFETY ADMINISTRATION: Adopt the U.S. Coast Guard's assumed average weight per person and amend the certification regulation in 49 Code of Federal Regulations Part 567 to specify that the gross vehicle weight rating for an amphibious passenger vehicle "shall not be less than the sum of the unloaded vehicle weight, the rated cargo load, and 185 pounds times the vehicle's number of designated seating positions."
H-16-019	OUA		NATIONAL HIGHWAY TRAFFIC SAFETY ADMINISTRATION: Classify all amphibious passenger vehicles (APV) as non-over-the-road buses and, under the authority of the National Traffic and Motor Vehicle Safety Act of 1966, make newly manufactured APVs subject to applicable Federal Motor Vehicle Safety Standards in effect at the time of manufacture.
H-17-019	OAA		TO THE NATIONAL HIGHWAY TRAFFIC SAFETY ADMINISTRATION: Identify speeding-related performance measures to be used by local law enforcement agencies, including "but not limited to" the numbers and locations of speeding-related crashes of different injury severity levels, speeding citations, and warnings, and establish a consistent method for evaluating data-driven, high-visibility enforcement programs to reduce speeding. Disseminate the performance measures and evaluation method to local law enforcement agencies.
H-17-020	OAA		TO THE NATIONAL HIGHWAY TRAFFIC SAFETY ADMINISTRATION: Identify best practices for communicating with law enforcement officers and the public about the effectiveness of data-driven, high-visibility enforcement programs to reduce speeding, and disseminate the best practices to local law enforcement agencies.

Overall Status: All Open

Addressee: NHTSA—Continued

Recommendation #	Overall Status	Date Closed	Subject
H-17-021	OAA		TO THE NATIONAL HIGHWAY TRAFFIC SAFETY ADMINISTRATION: Work with the Governors Highway Safety Association, the International Association of Chiefs of Police, and the National Sheriffs' Association to develop and implement a program to increase the adoption of speeding-related Model Minimum Uniform Crash Criteria Guideline data elements and improve consistency in law enforcement reporting of speeding-related crashes.
H-17-022	OAA		TO THE NATIONAL HIGHWAY TRAFFIC SAFETY ADMINISTRATION: Work with the Federal Highway Administration to update the Speed Enforcement Camera Systems Operational Guidelines to reflect the latest automated speed enforcement (ASE) technologies and operating practices, and promote the updated guidelines among ASE program administrators.
H-17-023	OAA		TO THE NATIONAL HIGHWAY TRAFFIC SAFETY ADMINISTRATION: Work with the Federal Highway Administration to assess the effectiveness of point-to-point speed enforcement in the United States and, based on the results of that assessment, update the Speed Enforcement Camera Systems Operational Guidelines, as appropriate.
H-17-024	OAA		TO THE NATIONAL HIGHWAY TRAFFIC SAFETY ADMINISTRATION: Incentivize passenger vehicle manufacturers and consumers to adopt intelligent speed adaptation (ISA) systems by, for example, including ISA in the New Car Assessment Program.
H-17-025	OAA		TO THE NATIONAL HIGHWAY TRAFFIC SAFETY ADMINISTRATION: Collaborate with other traffic safety stakeholders to develop and implement an ongoing program to increase public awareness of speeding as a national traffic safety issue. The program should include, but not be limited to, initiating an annual enforcement mobilization directed at speeding drivers.
H-17-026	OAA		TO THE NATIONAL HIGHWAY TRAFFIC SAFETY ADMINISTRATION: Establish a program to incentivize state and local speed management activities.
H-17-038	OAA		Develop a method to verify that manufacturers of vehicles equipped with Level 2 vehicle automation systems incorporate system safeguards that limit the use of automated vehicle control systems to those conditions for which they were designed.
H-17-039	OAA		TO THE NATIONAL HIGHWAY TRAFFIC SAFETY ADMINISTRATION: Use the data parameters defined by the U.S. Department of Transportation in response to Safety Recommendation H-17-37 as a benchmark for new vehicles equipped with automated vehicle control systems so that they capture data that reflect the vehicle's control status and the frequency and duration of control actions needed to adequately characterize driver and vehicle performance before and during a crash; the captured data should be readily available to, at a minimum, National Transportation Safety Board investigators and National Highway Traffic Safety Administration regulators.
H-17-040	OAA		TO THE NATIONAL HIGHWAY TRAFFIC SAFETY ADMINISTRATION: Define a standard format for reporting automated vehicle control systems data, and require manufacturers of vehicles equipped with automated vehicle control systems to report incidents, crashes, and vehicle miles operated with such systems enabled.
H-17-062	OAA		TO THE NATIONAL HIGHWAY TRAFFIC SAFETY ADMINISTRATION: Work with SAE International and the Federal Motor Carrier Safety Administration to improve truck-tractor side-mounted fuel tank crashworthiness to prevent catastrophic tank ruptures and limit postcollision fuel spillage, and develop and promulgate an updated standard.
H-18-008	OAA		TO THE NATIONAL HIGHWAY TRAFFIC SAFETY ADMINISTRATION: Require all new school buses to be equipped with collision avoidance systems and automatic emergency braking technologies.
H-18-029	OAA		TO THE NATIONAL HIGHWAY TRAFFIC SAFETY ADMINISTRATION: Incorporate motorcycles in the development of performance standards for passenger vehicle crash warning and prevention systems.
H-18-030	OAA		TO THE NATIONAL HIGHWAY TRAFFIC SAFETY ADMINISTRATION: Incorporate motorcycles in the development of performance standards for connected vehicle-to-vehicle systems.

Overall Status: All Open

Addressee: NHTSA—Continued

Recommendation #	Overall Status	Date Closed	Subject
H-18-031	OAA		TO THE NATIONAL HIGHWAY TRAFFIC SAFETY ADMINISTRATION: Work with the Federal Highway Administration to incorporate motorcycles in the development of performance standards for connected vehicle-to-infrastructure systems.
H-18-032	OUA		TO THE NATIONAL HIGHWAY TRAFFIC SAFETY ADMINISTRATION: Require all new motorcycles manufactured for on-road use in the United States be equipped with antilock braking system technology.
H-18-033	OAA		TO THE NATIONAL HIGHWAY TRAFFIC SAFETY ADMINISTRATION: Conduct or sponsor research to evaluate the effectiveness of stability control systems for motorcycles.
H-18-034	OAA		TO THE NATIONAL HIGHWAY TRAFFIC SAFETY ADMINISTRATION: Based on the research recommended in Safety Recommendation H-1833, develop and publish performance standards for stability control systems on motorcycles, and require systems meeting those standards on all new motorcycles manufactured for on-road use in the United States.
H-18-035	OAA		TO THE NATIONAL HIGHWAY TRAFFIC SAFETY ADMINISTRATION: Examine the influence of alcohol and other drug use on motorcycle rider crash risk compared to that of passenger vehicle drivers, and develop guidelines to assist states in implementing evidence-based strategies and countermeasures to more effectively address substance-impaired motorcycle rider crashes.
H-18-036	OAA		TO THE NATIONAL HIGHWAY TRAFFIC SAFETY ADMINISTRATION: Evaluate the effectiveness of state motorcycle licensing procedures for reducing motorcycle crashes, injuries, and fatalities among novice and unlicensed riders; based on the results of that evaluation, update the Guidelines for Motorcycle Operator Licensing or other guidance as appropriate.
H-18-039	OUA		TO THE NATIONAL HIGHWAY TRAFFIC SAFETY ADMINISTRATION: Revise Federal Motor Vehicle Safety Standard 108 to include performance-based standards for vehicle headlight systems correctly aimed on the road and tested on-vehicle to account for headlight height and lighting performance.
H-18-040	OAA		TO THE NATIONAL HIGHWAY TRAFFIC SAFETY ADMINISTRATION: Revise Federal Motor Vehicle Safety Standard 108 to allow adaptive headlight systems.
H-18-041	OUA		TO THE NATIONAL HIGHWAY TRAFFIC SAFETY ADMINISTRATION: Develop performance test criteria for vehicle designs that reduce injuries to pedestrians.
H-18-042	OAA		TO NATIONAL HIGHWAY TRAFFIC SAFETY ADMINISTRATION: Develop performance test criteria for manufacturers to use in evaluating the extent to which automated pedestrian safety systems in light vehicles will prevent or mitigate pedestrian injury.
H-18-043	OAA		TO THE NATIONAL HIGHWAY TRAFFIC SAFETY ADMINISTRATION: Incorporate pedestrian safety systems, including pedestrian collision avoidance systems and other more-passive safety systems, into the New Car Assessment Program.
H-18-044	OAA		TO THE NATIONAL HIGHWAY TRAFFIC SAFETY ADMINISTRATION: Develop a detailed pedestrian crash data set that represents the current, complete range of crash types and that can be used for local and state analysis and to model and simulate pedestrian collision avoidance systems.
H-18-045	OAA		TO THE NATIONAL HIGHWAY TRAFFIC SAFETY ADMINISTRATION: Work with the Centers for Disease Control and Prevention to develop and implement a plan for the states to combine highway crash data and injury health data, with the goal of producing a national database of pedestrian injuries and fatalities. (Supersedes H-13-026)
H-18-046	OAA		TO THE NATIONAL HIGHWAY TRAFFIC SAFETY ADMINISTRATION: Examine the past framework of the Crash Outcome Data Evaluation System and establish methods that states and metropolitan planning organizations can use to collect pedestrian event data, then define a common framework that will allow those data sources to be combined.
H-18-050	OAA		TO THE NATIONAL HIGHWAY TRAFFIC SAFETY ADMINISTRATION: Assess, and if necessary, update the guidelines on pupil transportation safety to specifically address pedestrian issues related to conspicuity and route selection.
H-18-056	OAA		Develop and disseminate best practices, identify model specifications, and create a conforming products list for oral fluid drug screening devices.

Overall Status: All Open

Addressee: NHTSA—Continued

Recommendation #	Overall Status	Date Closed	Subject
H-18-057	OAA		TO THE NATIONAL TRAFFIC SAFETY ADMINISTRATION: Evaluate best practices and countermeasures found to be the most effective in reducing fatalities, injuries, and crashes involving drug-impaired drivers and provide additional guidance to the states on drug-impaired driving in Countermeasures That Work: A Highway Safety Countermeasure Guide for State Highway Safety Offices.
H-18-058	OAA		TO THE NATIONAL TRAFFICS SAFETY ADMINISTRATION: Amend Federal Motor Vehicle Safety Standard 210 to increase the minimum anchorage spacing for individual seat belt assemblies, taking into account the dynamic testing of seat belt designs, seat belt fit, and vehicle configuration.
H-18-059	OAA		TO THE NATIONAL TRAFFIC SAFETY ADMINISTRATION: Amend Federal Motor Vehicle Safety Standard 208 to require lap/shoulder belts for each passenger seating position on all new buses with a gross vehicle weight rating of more than 10,000 pounds but not greater than 26,000 pounds.
H-19-004	OAR		NATIONAL HIGHWAY TRAFFIC SAFETY ADMINISTRATION: Require all new school buses to be equipped with fire suppression systems that at a minimum address engine fires.
H-19-005	OAR		TO THE NATIONAL HIGHWAY TRAFFIC SAFETY ADMINISTRATION: Develop standards for newly manufactured school buses, especially those with engines that extend beyond the firewall, to ensure that no hazardous quantity of gas or flame can pass through the firewall from the engine compartment to the passenger compartment.
H-19-014	OAR		TO THE NATIONAL HIGHWAY TRAFFIC SAFETY ADMINISTRATION: Require lap/shoulder belts for each passenger seating position on all new vehicles modified to be used as limousines.
H-19-015	OAR		TO THE NATIONAL HIGHWAY TRAFFIC SAFETY ADMINISTRATION: Require that seating systems installed in new vehicles modified to be used as limousines meet minimum performance standards to ensure their integrity during a crash.
H-99-009	OUA		TO THE NATIONAL HIGHWAY TRAFFIC SAFETY ADMINISTRATION: Revise the Federal Motor Vehicle Safety Standard 217, "Bus Window Retention and Release," to require that other than floor-level emergency exits can be easily opened and remain open during an emergency evacuation when a motorcoach is upright or at unusual attitudes.
H-99-049	OUA		TO THE NATIONAL HIGHWAY TRAFFIC SAFETY ADMINISTRATION: Expand your research on current advanced glazing to include its applicability to motorcoach occupant ejection prevention, and revise window glazing requirements for newly manufactured motorcoaches based on the results of this research.
H-99-050	OUA		TO THE NATIONAL HIGHWAY TRAFFIC SAFETY ADMINISTRATION: In 2 years, develop performance standards for motorcoach roof strength that provide maximum survival space for all seating positions and that take into account current typical motorcoach window dimensions.
H-99-051	OUA		TO THE NATIONAL HIGHWAY TRAFFIC SAFETY ADMINISTRATION: Once performance standards have been developed for motorcoach roof strength, require newly manufactured motorcoaches to meet those standards.

---

**Total Number of Recommendations for Recommendation Subjects Report: 110**

---

