



Safety Recall: 2003–07 Accord Power Steering Feed Hose Leak (Supersedes 12-066, dated September 27, 2012; see REVISION SUMMARY)

REVISION SUMMARY

An example of the customer letter was added.

BACKGROUND

Shortly, your customer will receive a recall notice regarding the P/S feed hose. A second recall notice will be sent to the customer when improved parts are available.

If a concerned customer comes in before receiving the second notice (to bring their vehicle in to have the improved part installed), inspect the power steering feed hose for damage or leaks. If any damage or leak is found, replace it with current parts stock and advise the customer to return when they receive the customer letter advising them that an improved hose is available. If no damage or leak is found, assure the customer that their hose should be OK until the improved hose is available.

CUSTOMER NOTIFICATION

Owners of affected vehicles will receive a notification of this campaign in October 2012.

Do an **iN VIN status inquiry** to make sure the vehicle is shown as eligible.

Some vehicles affected by this campaign may be in your used vehicle inventory. These vehicles must be inspected before they are sold. If the power steering feed hose has any damage or leaks, make an interim repair by replacing the hose with current parts stock.

Should a dealership sell a vehicle without first having inspected it (and conducting any necessary interim repair) and subsequently there is injury or damage because of the failure of a power steering feed hose, the dealership could be solely responsible to the damaged party, and may be required to defend and indemnify American Honda for any resulting claims. To see if a vehicle in inventory is affected by this campaign, do an iN VIN status inquiry before selling it.

CORRECTIVE ACTION

Inspect and, if necessary, install a power steering feed hose.

PARTS INFORMATION

P/S Feed Hose: P/N 53713-SDB-A01
P/S Switch O-ring: P/N 91304-P0H-013

REQUIRED MATERIALS

Honda Genuine Power Steering Fluid:
P/N 08206-9002
(Each vehicle may need up to three 12 oz. bottles.)

WARRANTY CLAIM INFORMATION

OP#	Description	FRT
5135A4	Inspect the P/S feed hose.	0.2
5121G7	Replace the P/S feed hose.	1.2

Failed Part: P/N 53713-SDB-A01

Defect Code: 5NT00

Symptom Code: S5900

Skill Level: Repair Technician

NOTE: You must obtain DPSM authorization for replacing the P/S feed hose.



INSPECTION PROCEDURE

1. Carefully inspect the power steering feed hose for leaks or damage.
 - If there are any leaks or damage found, go to REPAIR PROCEDURE.
 - If there are no leaks visible, go to step 2.
2. With the vehicle in P (or N for M/T) and the parking brake set, start the engine, and turn the steering all the way to full lock. With the steering wheel in full lock, inspect the hose for seepage or leaks. Turn the steering wheel in the opposite direction until it reaches full lock, then check again for seepage or leaks.

NOTE: The leaks are typically very small. If you don't see an active leak, check for evidence of a leak, such as the hose being damp, "hose sweat," or dust that appears damp stuck to the hose.

- If there is any seepage or leaks, obtain DPSM approval, and go to REPAIR PROCEDURE.
- If there is no seepage or leaks, assure the customer that the P/S hose is OK at this time. Remind them that they will need to return when they receive a notification that the new part is available.

REPAIR PROCEDURE

NOTE: You must obtain DPSM approval before doing this repair.

1. Drain the P/S fluid.
 - Raise the reservoir, then disconnect the return hose to drain the reservoir. Take care not to spill the fluid. Wipe off any spilled fluid immediately.
 - Connect a properly sized hose to the disconnected return hose, and put the hose in a container large enough to hold the fluid.
 - Start the engine, let it idle, then turn the steering wheel from lock-to-lock several times. When the fluid stops running out of the hose, turn off the engine. Discard the fluid.
 - Reinstall the return hose on the reservoir.

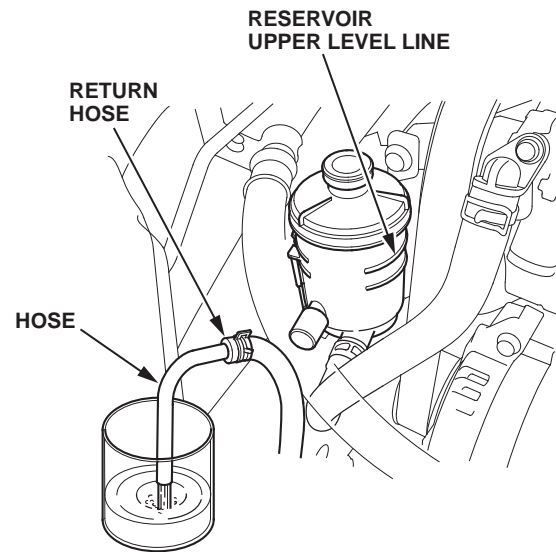

2. Remove the P/S pump outlet hose from the P/S pump, then plug the outlet hose and the P/S pump. Remove the P/S feed hose from the clamp.

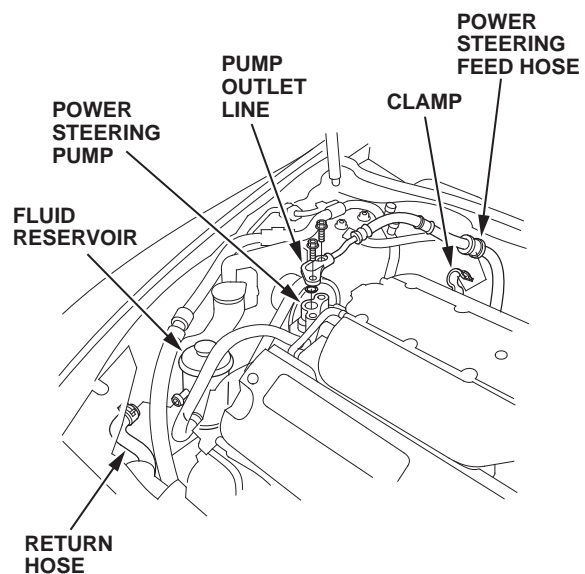

3. Disconnect the P/S pressure switch connector.

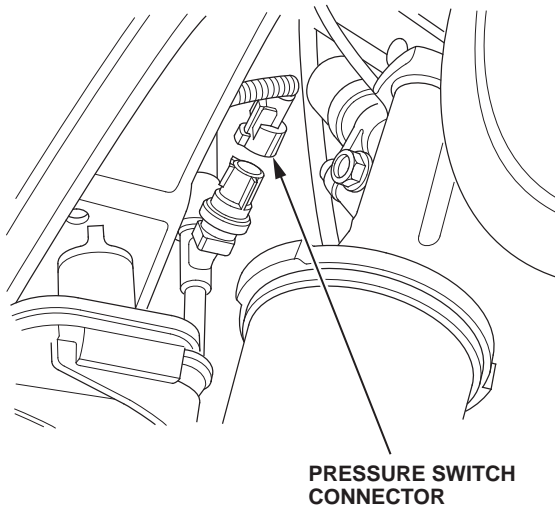

4. Remove the bolts securing the feed hose holders.

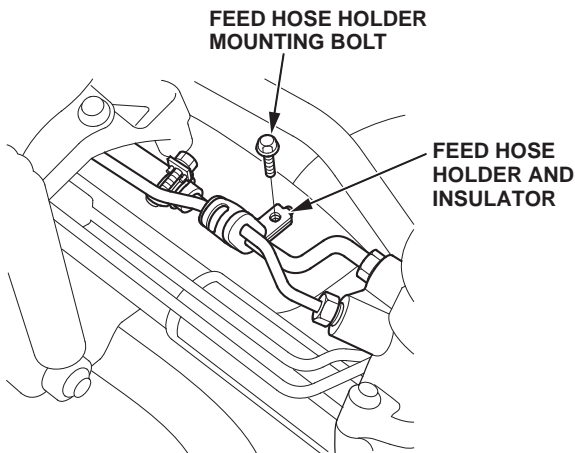
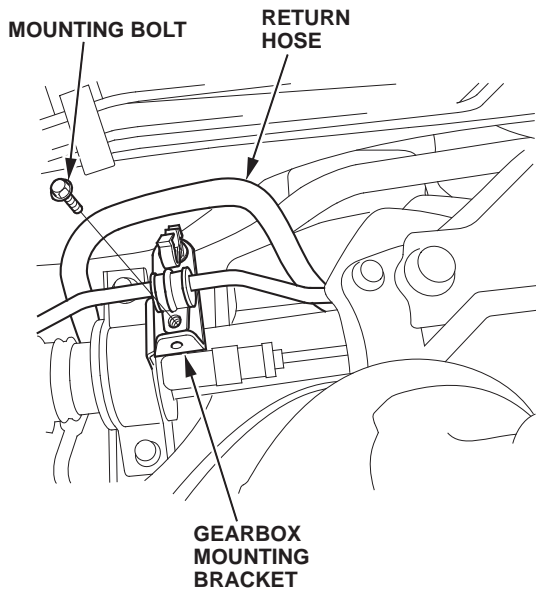

5. Raise the vehicle on a lift.

6. Remove the P/S heat baffle plate.

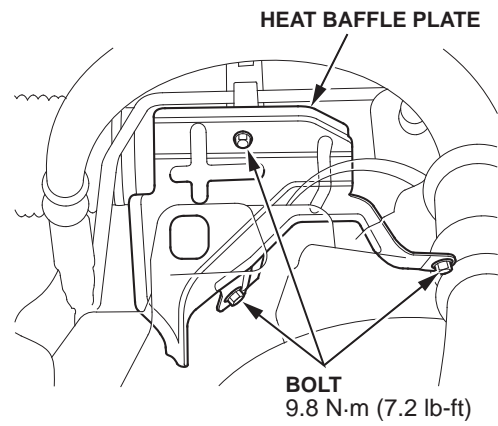

7. Lower the vehicle.
8. Disconnect the P/S feed hose from the steering gearbox by loosening its flare nut.

NOTE: To prevent fluid from dripping, place several shop towels under the feed hose connection, and wrap a towel around the exposed joint end.

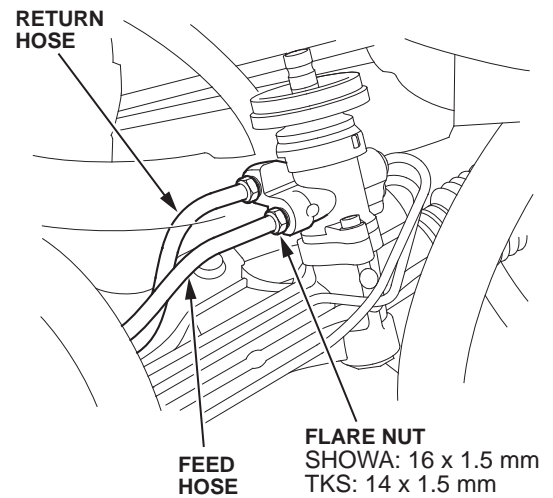

9. Raise the vehicle, and remove the exhaust hanger bracket bolts, and slide the exhaust hanger to the rear of the vehicle.

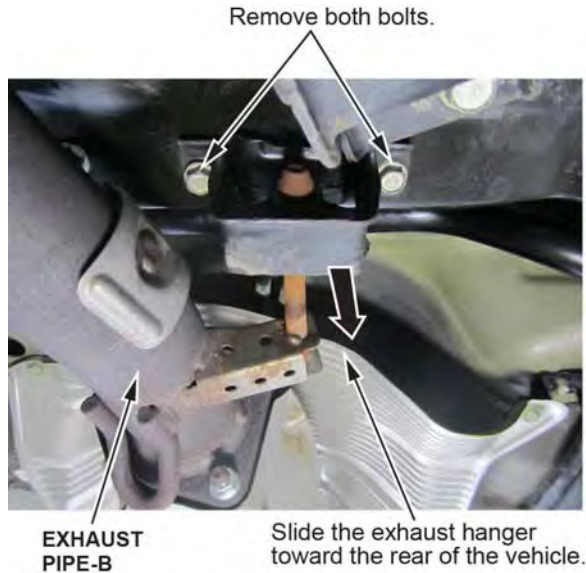

10. Remove three of the rear engine mount bracket bolts from the subframe. Loosen the fourth bolt 20-25 mm and make sure that it is still threaded.

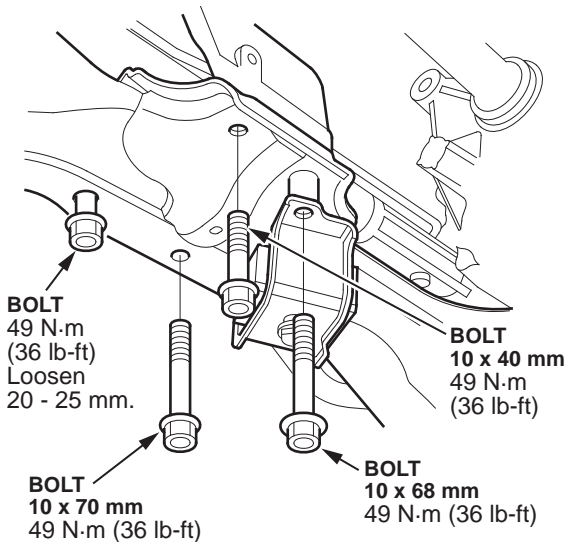

11. Using a transmission jack, carefully lift the engine until the rear engine bracket lifts off the rear part of the subframe.

NOTE: To minimize stress damage on the other engine/transmission mounts, do not lift the assembly too much.

12. Push up on the rear engine mount bracket and remove the P/S feed hose. Wipe up any P/S fluid that may have spilled.
13. Lower the transmission jack, then lower the vehicle.

14. Remove the P/S feed hose from the top of the engine. Make sure you don't damage the high pressure switch because it will be reused.

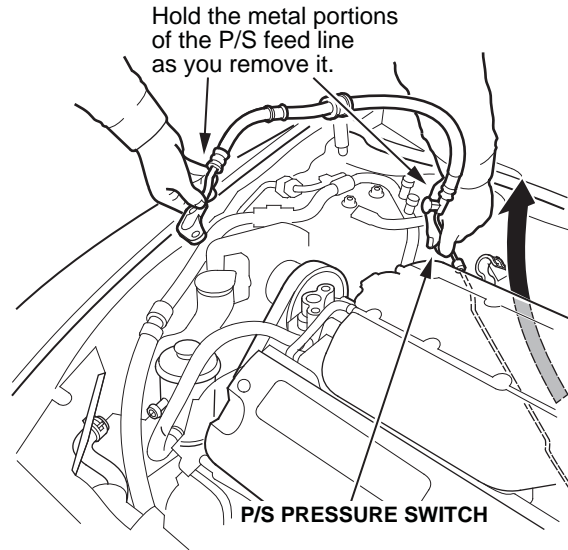

15. Transfer the P/S pressure switch from the old feed hose and install it on the new one with a new O-ring. Torque the switch to **12 N·m (8.7 lb-ft)**.

16. Install the replacement P/S hose.

17. Raise the vehicle.

18. Reconnect the P/S feed hose, and torque the flare nut to **28 N·m (21 lb-ft)**.

19. Reinstall, and torque the rear engine mount bracket bolts to **49 N·m (36 lb-ft)**.

20. Reinstall the exhaust hanger.

21. Reinstall the P/S heat baffle plate, and torque the bolts to **9.8 N·m (7.2 lb-ft)**.

22. Reinstall the feed hose holders, and torque the bolts to **9.8 N·m (7.2 lb-ft)**.

23. Lower the vehicle, and connect the P/S pressure switch connector.

24. Fill the P/S reservoir to the upper level line.

NOTE:

- Use Honda Genuine Power Steering Fluid.
- The system capacity is **1.1 L (37.2 oz)**.
- The reservoir capacity is **0.32 L (10.8 oz)**.

25. Start the engine, run it at a fast idle, and turn the steering wheel lock-to-lock several times. This will bleed any air from the P/S system.

26. Recheck the fluid level, and add more if needed. Do not fill the reservoir above the upper level line.

NOTE:

- Make sure you remove all shop towels used during the procedure.
- Wipe off any spilled P/S fluid.

Example of Customer Letter

October 2012

**Safety Recall: 2003–07 Accord Power Steering
Feed Hose Leak - NHTSA Recall 12V-222**

Dear Honda Accord Owner:

This notice is sent to you in accordance with the requirements of the National Traffic and Motor Vehicle Safety Act.

What is the reason for this notice?

Honda has decided that a defect which relates to motor vehicle safety exists in certain 2003–2007 model year Accord V6 vehicles. Prolonged high under-hood temperatures and high power steering fluid temperatures may cause the power steering hose to deteriorate prematurely and may cause the hose to crack and leak power steering fluid. Fluid leaking onto a hot catalytic converter will generate smoke, a burning smell and possibly lead to an under-hood fire.

What should you do?

Parts to complete the repair will begin to arrive at dealerships in early 2013. Honda will send you another letter when parts are available to repair your vehicle.

If you have questions

If you have any questions about this notice or any concerns or questions about your vehicle, please call Honda Automobile Customer Service at 800-999-1009, and select option 4.

What to do if you feel this notice is in error

Registration records indicate that you are the current owner or lessee of a 2003–2007 Honda Accord V6 involved in this campaign. If this is not the case, or the name/address information is not correct, please complete and sign the Information Change Card and return it in the enclosed postage-paid envelope. We will then update our records

Lessor Information

Federal law requires that any vehicle lessor receiving this recall notice must forward a copy of this notice to the lessee within 10 days.

We apologize for any inconvenience this campaign may cause you.

Sincerely,

**American Honda Motor Co., Inc.
Honda Automobile Division**