

TP-201P-00
August 19, 1999

U.S. DEPARTMENT OF TRANSPORTATION
NATIONAL HIGHWAY TRAFFIC SAFETY ADMINISTRATION
LABORATORY TEST PROCEDURE
FOR
FMVSS 201
RIGID POLE SIDE IMPACT TEST



U.S. Department of Transportation
National Highway Traffic Safety Administration
Office of Vehicle Safety Compliance (NSA-30)
400 7th Street, S.W., Room 6111
Washington, DC 20590

LABORATORY TEST PROCEDURE NO. TP-201P
TABLE OF CONTENTS

	PAGE
1. PURPOSE AND APPLICATION.....	1
2. GENERAL REQUIREMENTS.....	2
3. SECURITY	3
4. GOOD HOUSEKEEPING.....	5
5. TEST SCHEDULING AND MONITORING	5
6. FACILITY AND EQUIPMENT	
6.1 Tow Road	5
6.2 Test Vehicle Preparation Building.....	5
6.3 Tow and Guidance Systems	6
6.4 Rigid Pole	6
6.5 Test Vehicle Velocity Measurement.....	8
6.6 Test Brake Abort System.....	8
6.7 Notification of COTR.....	9
7. GOVERNMENT FURNISHED PROPERTY (GFP)	
7.1 Test Vehicles	9
7.2 Side Impact Hybrid Dummy (SID/HIII)	10
8. INSTRUMENTATION AND CALIBRATION REQUIREMENTS	
8.1 General Requirements.....	10
8.2 SID/HIII Instrumentation.....	12
8.3 SID/HIII Calibration	17
8.4 Drawing List for SID/HIII	17
8.5 Test Vehicle Instrumentation	21
8.6 Impact Line Marker	23
9. PHOTOGRAPHIC DOCUMENTATION	
9.1 Ground Based Cameras Required.....	25
9.2 Test Vehicle Onboard Cameras Required	26
9.3 Coloring Requirements for Photographic Purposes	27
9.4 Vehicle and Dummy Photographic Coverage (Real Time).....	27
9.5 Impact Event Markers	28
9.6 Photographic Targets and Tape for Test Vehicle.....	28
9.7 Target Vehicle Information Placards.....	30
9.8 Crash Film Title, Heading and Sequence	30
9.9 Still Photographs.....	31
9.10 Vehicle Measurements	32

TABLE OF CONTENTS....Continued

10.	DEFINITIONS	34
11.	TEST EXECUTION	
11.1	Test Vehicle Preparation.....	35
11.2	Dummy Preparation, Positioning and Placement.....	44
12.	TEST DATA	
12.1	Performance Requirements	50
12.2	Data Processing	52
12.3	Computer Data Tape	52
12.4	Data Loss (Retest).....	52
12.5	Partial Payment	53
12.6	Data Retention by Contractor	53
12.7	Data Sheets	53
13.	FORMS	76

APPENDICES

- A. Laboratory Configuration and Performance Verification Procedure
- B. Initial Positioning Procedure for SID/HIII
- C. Head-Neck Bracket Assembly

REVISION CONTROL LOG
FOR OVSC LABORATORY
TEST PROCEDURES

TP201P
RIGID POLE SIDE IMPACT TEST

TEST PROCEDURE		FMVSS 201		DESCRIPTION
REV. No.	DATE	AMENDMENT	EFFECTIVE DATE	
00	8/19/99			Original release signed by O.D.
01				
02				
03				
04				
05				
06				
07				
08				

1. PURPOSE AND APPLICATION

The Office of Vehicle Safety Compliance (OVSC) provides contractor laboratories with Laboratory Test Procedures as guidelines for obtaining compliance test data. The data are used to determine if a specific vehicle or item of motor vehicle equipment meets the minimum performance requirements of the subject Federal Motor Vehicle Safety Standard (FMVSS). The purpose of the OVSC Laboratory Test Procedures is to present a uniform testing and data recording format, and provide suggestions for the use of specific equipment and procedures. If any contractor views any part of an OVSC Laboratory Test Procedure to be in conflict with a Federal Motor Vehicle Safety Standard (FMVSS) or observes deficiencies in a Laboratory Test Procedure, the contractor is required to advise the Contracting Officer's Technical Representative (COTR) and resolve the discrepancy prior to the start of compliance testing.

Every contractor is required to submit a detailed test procedure to the COTR before initiating the compliance test program. The procedure must include a step-by-step description of the methodology to be used. The contractor's test procedure shall contain a complete listing of test equipment with make and model number and a detailed check-off sheet. The list of test equipment shall include instrument accuracy and calibration dates. All equipment shall be calibrated in accordance with the manufacturer's instructions. There shall be no contradictions between the Laboratory Test Procedure and the contractor's in-house test procedure. Written approval of the in-house test procedures shall be obtained from the COTR before initiating the compliance test program. The OVSC Laboratory Test Procedures are not intended to limit or restrain a contractor from developing or utilizing any testing techniques or equipment which will assist in procuring the required compliance test data. These Laboratory Test Procedures do not constitute an endorsement or recommendation for use of any product or method. However, the application of any such testing technique or equipment is subject to prior approval of the COTR.

NOTE: The OVSC Laboratory Test Procedures, prepared for the limited purpose of use by independent laboratories under contract to conduct compliance tests for the OVSC, are not rules, regulations or NHTSA interpretations regarding the meaning of a FMVSS. The Laboratory Test Procedures are not intended to limit the requirements of the applicable FMVSS(s). In some cases, the OVSC Laboratory Test Procedures do not include all of the various FMVSS minimum performance requirements. Recognizing applicable test tolerances, the Laboratory Test Procedures may specify test conditions that are less severe than the minimum requirements of the standard.

1. PURPOSE AND APPLICATION....Continued

In addition, the Laboratory Test Procedures may be modified by the OVSC at any time without notice, and the COTR may direct or authorize contractors to deviate from these procedures, as long as the tests are performed in a manner consistent with the standard itself and within the scope of the contract. Laboratory Test Procedures may not be relied upon to create any right or benefit in any person. Therefore, compliance of a vehicle or item of motor vehicle equipment is not necessarily guaranteed if the manufacturer limits its certification tests to those described in the OVSC Laboratory Test Procedures.

2. GENERAL REQUIREMENTS

The upper interior impact requirements of FMVSS 201, Occupant Protection in Interior Impact, were amended to include an option for dynamically deployed upper interior head protection systems.

Each vehicle shall, when equipped with a dummy test device specified in part 572, subpart M, and tested as specified in S8.16 through S8.28 comply with the requirements specified in S7 when crashed into a fixed, rigid pole of 254 mm in diameter, at any velocity up to and including 29 kph (18 mph).

NOTE: The vehicle may be tested on either the left side (driver's side) or right side (passenger's side). This determination will be made by the COTR.

S7 Performance Criterion. The HIC(d) shall not exceed 1000 when calculated in accordance with the following formula:

$$HIC = \left[\frac{1}{t_2 - t_1} \int_{t_1}^{t_2} a \, dt \right]^{2.5} (t_2 - t_1)$$

where $A_R = [A_x^2 + A_y^2 + A_z^2]^{1/2}$ Resultant Acceleration magnitude in g units at the dummy head CG, and

t_1 and t_2 are any two points in time during the impact event which are separated by not more than a 36 millisecond time.

3. SECURITY

The contractor shall provide appropriate security measures to protect the NHTSA test vehicles, dummies and any Government Furnished Property from unauthorized personnel during the entire testing program. The contractor is financially responsible for any acts of theft and/or vandalism which occur during the storage of test vehicles. Any security problems which arise shall be reported by telephone to the Industrial Property Manager (IPM), Office of Contracts and Procurement, within two working days after the incident. A letter containing specific details of the security problem will be sent to the IPM (with copy to the COTR) within 48 hours.

The contractor shall protect and segregate the data that evolves from testing before and after each vehicle test. No information concerning the vehicle testing program shall be released to anyone except the COTR, unless specifically authorized by the COTR or the COTR's Branch or Division Chief.

The tested vehicles, protected from the elements, shall be retained by the test contractor for a MINIMUM of 60 days so that NHTSA personnel can be given an inspection opportunity.

NOTE: No individuals, other than contractor personnel directly involved in the testing program, shall be allowed to witness any NHTSA vehicle test unless specifically authorized by the COTR. It is the contractor's responsibility to secure the test site area during a test and to shield the impact area from the public view by the use of canvas or other blocking devices.

3. SECURITY....Continued

RULES FOR CONTRACTORS

- A. No vehicle manufacturer's representative(s) or anyone other than the contractor's personnel working on the NHTSA Contracts and NHTSA personnel, shall be allowed to inspect NHTSA vehicles or witness vehicle preparations without prior permission. Such permission can never be assumed.
- B. All communications with vehicle manufacturers shall be referred to the NHTSA. The contractor shall not release crash test data without the permission of the NHTSA.
- C. Unless otherwise specified, the vehicle manufacturer's representative(s) shall only be authorized to visit the contractor's test facility on the day that the test is scheduled, and the representative(s) must be escorted by NHTSA and/or contractor personnel.
- D. Test vehicle inspection by the vehicle manufacturer's representative(s) shall be limited to 30 minutes prior to the start of vehicle impact test. Post test inspection shall be limited to one (1) hour after contractor personnel have completed their test tasks.
- E. Photographs and videotapes of the test vehicle, associated test equipment and test event will be allowed. However, test personnel shall not be included in any photographic coverage, and videotaping of vehicle preparation must be approved by NHTSA. The contractor's personnel shall not respond to any questions from the manufacturer's representatives regarding the NHTSA test. All questions shall be referred to the COTR, a NHTSA representative present at the test site, or to NHTSA.
- F. The contractor shall permit public access to and inspection of the test vehicles and related data during the times specified by the NHTSA COTR. NHTSA shall advise interested parties that such access and inspection shall be limited to a specified day, and specified hours and require prior approval from the NHTSA. The contractor shall refer all visit requests from vehicle manufacturer's representatives to the NHTSA. This service shall be included as an incidental part of the crash test program and will not result in any additional cost to the NHTSA. The contractor shall make his own arrangements with interested parties for expenses incurred beyond providing access and inspection services.

4. GOOD HOUSEKEEPING

Contractors shall maintain the entire vehicle testing area, dummy calibration area, test fixtures and instrumentation in a neat, clean and painted condition with test instruments arranged in an orderly manner consistent with good test laboratory housekeeping practices.

5. TEST SCHEDULING AND MONITORING

The contractor shall submit a test schedule to the COTR prior to testing. Tests shall be completed as required in the contract. The COTR will make adjustments to the crash test schedule in cases of unusual circumstances such as inclement weather or difficulty experienced by the Agency in the procurement of a particular vehicle make and model.

Scheduling shall be adjusted to permit sample motor vehicles to be tested to other FMVSS as may be required by the NHTSA. All testing shall be coordinated to allow monitoring by the COTR.

6. FACILITY AND EQUIPMENT – PRETEST REQUIREMENTS

6.1 TOW ROAD

The tow road surface must be straight, level, smooth and uniform construction. The tow road must have sufficient length to allow for stabilization of the test vehicle velocity (approximately zero acceleration) prior to side impact with the rigid pole, and if necessary, to allow time for the vehicle to be stopped prior to impacting the pole in case of a test abort.

6.2 TEST VEHICLE PREPARATION BUILDING

In order that the test vehicle can be prepared for testing during hot or cold weather, a permanent wood or metal enclosure must be constructed which is large enough to house the test vehicle and allow for personnel movement around the test vehicle. The temperature inside the test vehicle must be maintained between 20.6EC and 22.2EC (69EF - 72EF) for a minimum of four (4) hours prior to the side impact event. The SID/HIII shall soak for 16 hours in a controlled environment of 20.6EC and 22.2EC prior to the impact event. The ambient temperature must be monitored and continuously recorded within 36 inches of the dummy until just before impact. Minor ($\pm .5$ EC) temperature fluctuations (above or below the specified 20.6EC to 22.2EC) are acceptable if they last less than a cumulative 5 minutes. The intent of the test procedure is to ensure that the core temperature and neck temperature of the SID/HIII is not out of specification for an extended period of time.

6. FACILITY AND EQUIPMENT – PRETEST REQUIREMENTS....Continued

6.3 TOW AND GUIDANCE SYSTEMS

The tow system must be capable of ensuring that the test vehicle shall impact the rigid pole laterally at a speed of 29 kph (FOR COMPLIANCE PURPOSES: 28.0 kph \pm 0.9 kph). The test vehicle conveyance shall be continuously towed up until 600 mm (approximately) from impact. The tow cable attachment device must release from the tow cable before impact. The test vehicle impact velocity measurement shall be taken after cable release.

A guidance system is required to assure that the test vehicle is propelled sideways so that its line of forward motion forms an angle of 90 degrees (\pm 3 degrees) with the vehicle's longitudinal center line and within \pm 38 mm (\pm 1.5 in) horizontally of the vehicle's impact reference line.

VEHICLE DELIVERY

Any vehicle delivery and guidance system that reduces test vehicle tire to track friction may be employed as long as the required test vehicle attitude and test weight are maintained. Some tow configurations may result in removing the tires and wheels completely. This is acceptable as long as the required test vehicle attitude and test weight distribution are maintained. The vehicle conveyance system is released from the tow cable (roughly 600 mm) prior to striking the pole.

The test vehicle shall be delivered laterally at a velocity of 29 kph (18 mph) (FOR COMPLIANCE PURPOSES: 28.0 kph \pm 0.9 kph).

6.4 RIGID POLE

The impact face of the rigid pole shall be a vertically oriented metal structure with a diameter of 254 mm \pm 3 mm and beginning no more than 102 mm above the lowest point of the tires on the struck side of the test vehicle (loaded according to S8.16) and extending at least 150 mm above the highest point of the roof of the test vehicle. The pole face shall be offset from its mounting and support such that the vehicle will not contact such within 100 ms from the initial vehicle-to-pole contact. The pole illustrated in the following figures is from the Federal Highway Administration's Turner-Fairbank Highway Research Center and is provided for illustrative purposes only.

6. FACILITY AND EQUIPMENT – PRETEST REQUIREMENTS...Continued

FOIL 300K RIGID POLE - All Measurements in mm

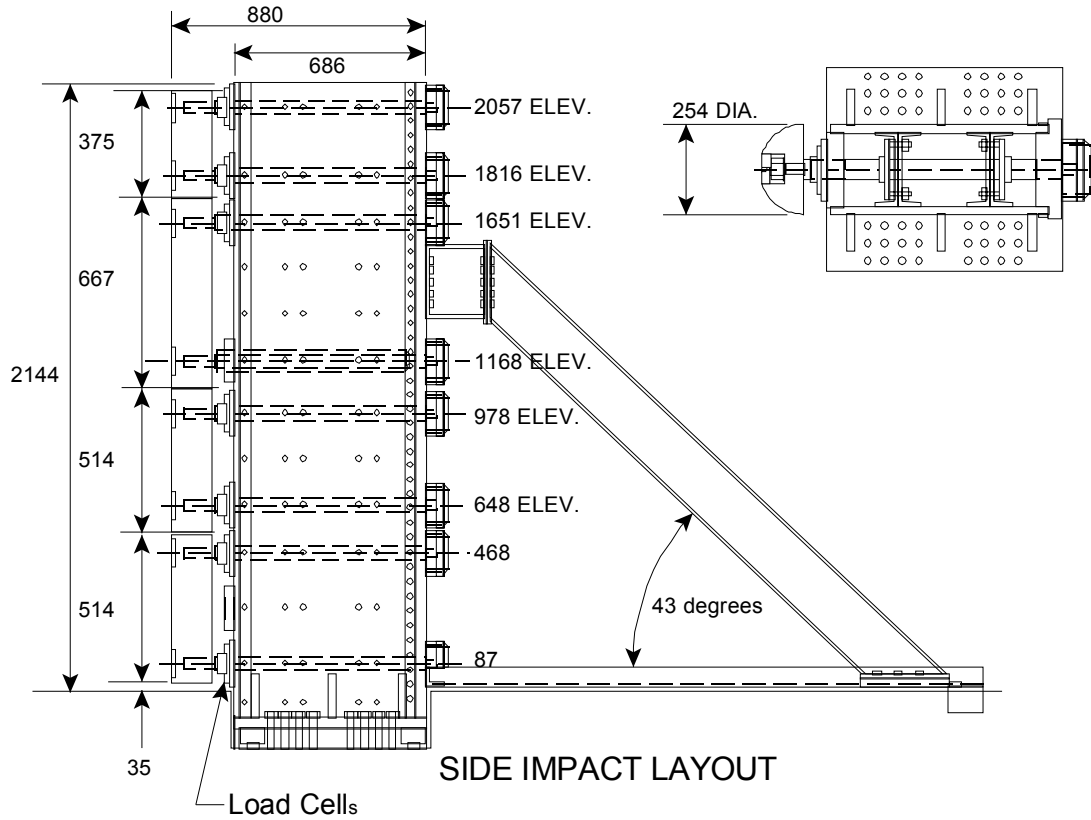

FIGURE 1

FOIL 300K RIGID POLE

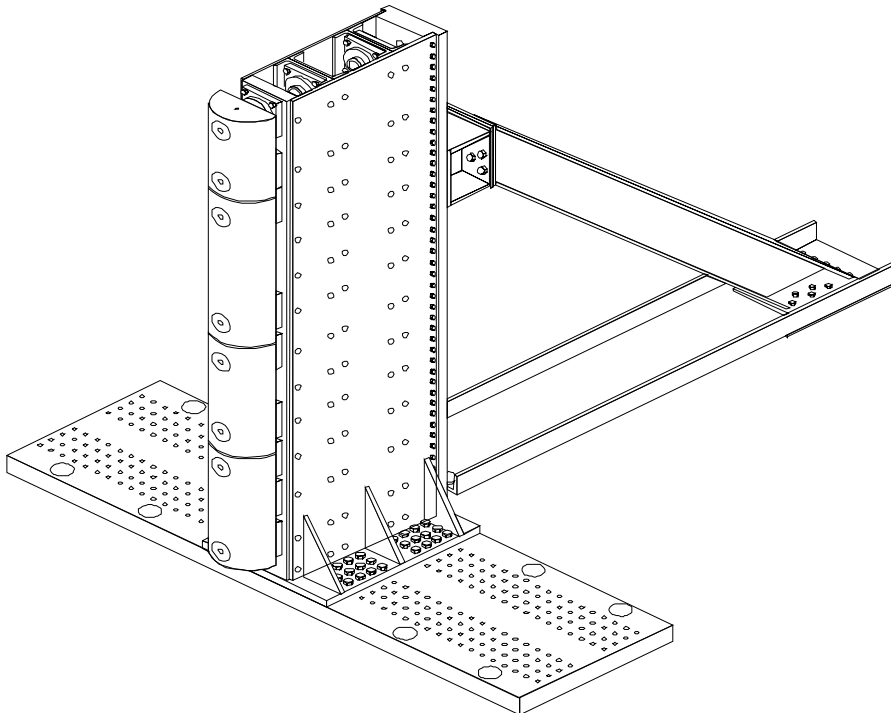

FIGURE 2

6.5 TEST VEHICLE VELOCITY MEASUREMENT

The speed of the test vehicle shall be controlled to obtain and maintain the vehicle speed at 29 kph (FOR COMPLIANCE PURPOSES: $28.0 \text{ kph} \pm 0.9 \text{ kph}$). Primary test vehicle impact speed measurement may be achieved by the use of break wires, photocells, or laser beams. Usually two sets of break wires or 2 photocell transmitters and receivers are used in the final speed trap which records the time, on an electronic counter, for the test vehicle to travel the last 1.5 m before pole impact. The test vehicle's velocity shall be constant (essentially having zero acceleration or deceleration) for a minimum of the last 1.5 m of travel before impact. The final velocity shall be measured (after tow system release) when the test vehicle is within 300 mm of the pole face, and the reported impact velocity will take into consideration all of the response characteristics of the entire velocity measurement system utilized in its determination.

Impact velocity will be measured by no less than 2 sets of timing devices and the timing devices shall be accurate to within $\pm 0.1 \text{ kph}$. The idea is to record the vehicle velocity over essentially the same distance with two separate devices. The basis of the velocity measurement (time and distance) shall be calibrated by an instrument traceable to the National Institute of Standards and Technology (NIST). The impact velocity shall be permanently recorded.

A timing device shall monitor the velocity of the test vehicle to permit aborting the test if the vehicle's speed is outside of the specified velocity range (**NOTE:** the use of an abort system will be dependent on the method of conveying the vehicle laterally down the track). The test vehicle shall impact the rigid pole at 29 kph (FOR COMPLIANCE PURPOSES: $28.0 \text{ kph} \pm 0.9 \text{ kph}$).

6.6 TEST BRAKE ABORT SYSTEM

The vehicle conveyance system will be equipped with an onboard brake abort system (if possible). Abort criteria consists of vehicle velocity, data acquisition and instrumentation system readiness, and stability of the vehicle on the tow road. The first two criterion are to be automatically monitored by the test control system while the third is manually monitored by the test director. For added safety, a manual abort shall be available from start, until the point at which the vehicle is impossible to stop without impacting the rigid pole.

6. FACILITY AND EQUIPMENT – PRETEST REQUIREMENTS....Continued

6.7 NOTIFICATION OF COTR

The COTR must be notified within 24 hours after a test vehicle has been delivered.

NOTE: The tested vehicles, protected from the elements, shall be retained by the test contractor for a MINIMUM of 60 days so that NHTSA personnel can be given an inspection opportunity.

7. GOVERNMENT FURNISHED PROPERTY (GFP)

7.1 TEST VEHICLES

The Contractor has the responsibility of accepting test vehicles from either new car dealers or vehicle transporters. In both instances, the contractor acts in the NHTSA's behalf when signing an acceptance of test vehicles. If a vehicle is delivered by a dealer, the contractor must check to verify the following:

- A. All options listed on the 'window sticker' are present on the test vehicle.
- B. Tires and wheel rims are the same as listed.
- C. There are no dents or other interior or exterior flaws.
- D. The vehicle has been properly prepared and is in running condition.
- E. The glove box contains an owner's manual, warranty document, consumer information, and extra set of keys.
- F. Proper fuel filler cap is supplied on the test vehicle.
- G. Spare tire, jack, lug wrench and tool kit (if applicable) is located in the vehicle cargo area.

The Contractor shall check for damage which may have occurred during transit. The COTR is to be notified of any damage prior to preparation of the vehicle for testing.

A 'Vehicle Condition' form will be supplied to the contractor by the COTR when the test vehicle is transferred from the new car dealer or between test contracts. The upper half of the form describes the vehicle in detail, and the lower half provides space for a detailed description of the post test condition. Vehicle Condition forms must be returned to the COTR with the copies of the Final Test Report or the reports will NOT be accepted.

7. GOVERNMENT FURNISHED PROPERTY (GFP)....Continued

7.2 SIDE IMPACT HYBRID DUMMY (SID/HIII)

An adequate number of **non-instrumented** Part 572 Subpart M side impact hybrid dummies (SID/HIIIs) will be furnished to the contract laboratory by the NHTSA. The dummies shall be stored in an upright seated position with the weight supported by the internal structure of the pelvis. The eye bolt in the top of the dummy's head shall not be used to support the SID during storage between tests. These dummies shall be stored in a secured room which is kept between 12.8EC and 29.4EC F(55EF and 85EF). The Contractor will check the dummy components for damage when performing the calibrations and complete a dummy damage checklist. The COTR will be kept informed of the dummies condition in order that replacement parts can be provided.

These dummies shall be calibrated by the Contractor before every vehicle-pole impact test and the calibration checked after every vehicle-pole impact test.

The contractor shall keep a detailed record for each SID/HIII, describing parts replaced and the results of calibration tests.

8. INSTRUMENTATION AND CALIBRATION REQUIREMENTS

8.1 GENERAL REQUIREMENTS

Contractors are required to supply all instrumentation necessary to conduct the test according to this test procedure. This will include, but is not limited to, all vehicle and dummy accelerometers and sensors.

Before the Contractor initiates the NHTSA test program, a test instrumentation calibration system will be implemented and maintained in accordance with established calibration practices. Instrumentation and sensors used must also conform to the SAE J211 1/2 MAR95 recommended practice requirements. The analog data shall be recorded in accordance with SAE J211 1/2 MAR95 channel filter class 1000 specification.

The calibration system shall include the following as a minimum:

- A. Standards for calibrating the measuring and test equipment will be stored and used under appropriate environmental conditions to assure their accuracy and stability.

8. INSTRUMENTATION AND CALIBRATION REQUIREMENTS....Continued

- B. All measuring instruments and standards shall be calibrated by the contractor, or a commercial facility, against a higher order standard at periodic intervals not to exceed 6 months for instruments and twelve (12) months for the calibration standards. Records, showing the calibration traceability to the National Institute of Standards and Technology (NIST), shall be maintained for all measuring and test equipment.
- C. All measuring and test equipment and measuring standards will be labeled with the following information:
- (1) Date of calibration
 - (2) Date of next scheduled calibration
 - (3) Name of the technician who calibrated the equipment
- D. A written calibration procedure shall be provided by the Contractor which includes as a minimum the following information for all measurement and test equipment:
- (1) Type of equipment, manufacturer, model number, etc.
 - (2) Measurement range
 - (3) Accuracy
 - (4) Calibration interval
 - (5) Type of standard used to calibrate the equipment (calibration traceability of the standard must be evident)
- E. Records of calibration for all test instrumentation shall be kept by the contractor in a manner which assures the maintenance of established calibration schedules. All such records shall be readily available for inspection when requested by the COTR. The calibration system will need the acceptance of the COTR before testing commences.

ACCELEROMETER CALIBRATION

- A. All vehicle and dummy based accelerometers shall be calibrated by the contractor, or a commercial facility, against a standard at periodic intervals not to exceed six (6) months, or every 4 tests, or after a vehicle fails to meet FMVSS 201 performance requirements, whichever occurs first. Records, showing the calibration traceability to the National Institute of Standards and Technology (NIST), shall be maintained for each sensor.

8. INSTRUMENTATION AND CALIBRATION REQUIREMENTS....Continued

- B. Records of the calibrations for all accelerometers shall be kept by the contractor in a manner which assures the maintenance of established calibration schedules. Records, including dates and sensitivity values from the most recent THREE (3) calibrations, shall be readily available for inspection before testing commences and when requested by the COTR. A listing of each accelerometer and date of most recent calibration should be included in the Final Test Report.

Further guidance is provided in the International Standard ISO 10012-1, "Quality Assurance Requirements For Measuring Equipment," and American National Standard ANSI/NCSL Z540-1, "Calibration Laboratories and Measuring and Test Equipment – General Requirements."

NOTE: In the event of a test failure or data anomaly, additional calibration checks of some critically sensitive test equipment, instrumentation, and sensors may be required. The necessity for the calibration will be at the COTR's discretion and will be performed without additional cost.

8.2 SIDE IMPACT HYBRID DUMMY (SID/HIII) INSTRUMENTATION

The full vehicle test concept requires the use of human surrogates to determine the injury levels. The Part 572 Subpart M, Side Impact Hybrid Dummy , 50th Percentile Male, SID/HIII, has been chosen as the appropriate Anthropomorphic Test Device (ATD).

The SID/HIII is a hybrid dummy in which the Side Impact Dummy (SID), Part 572(F), was combined with the Hybrid III head and neck, Part 572(E). A new neck bracket has been designed to preserve the head/neck alignment for the SID and ensure that the hybrid dummy is within the seating height of the 50th percentile male and the SID (See drawings 96-SIDH3-001 thru 96-SIDH3-004). The SID/HIII is generally configured for left side impact. For a right side impact, the damper must be rotated 180 degrees from the configured orientation. The test vehicle may be impacted on either side. The COTR will decide whether the test should be conducted on the left or right side.

8. INSTRUMENTATION AND CALIBRATION REQUIREMENTS....Continued

HEAD AND NECK INSTRUMENTATION

The SID/HIII head cavity shall be instrumented with three (3) accelerometers to measure orthogonal accelerations (A_x , A_y and A_z) at the center-of-gravity (CG) of the head assembly. The 3 accelerometers shall be mounted in an orthogonal array, and the intersection of the planes containing the sensitive axis of the 3 sensors will be the origin of the array. Head accelerometers shall have dimensions, response characteristics and sensitive mass locations specified in P572(E) drawing 78051-136 Rev. A and be mounted in the head as shown in P572(E) drawing 78051-61X Rev. C.

The SID/HIII upper neck shall be instrumented with a six axis load cell (F_x , F_y , F_z , M_x , M_y , M_z). Neck transducers shall have the dimensions, response characteristics and sensitive axis locations specified in P572(E) drawing C1709.

As with the accelerometers, the Contractor shall provide and install a calibrated six axis load cell in each dummy.

NOTE: The Contractor shall provide the necessary equipment to record the data from this load cell (F_x , F_y , F_z , M_x , M_y , M_z) and include the data in the final test report and data tape/diskette.

CHEST INSTRUMENTATION

The SID/HIII thorax and pelvic regions shall be instrumented with Endevco Model 7264-2000g (or equivalent) uniaxial accelerometers (configured for Y axis sensitivity according to impact condition, redundant accelerometers may be required (final decision will be made by COTR) and their locations are clearly indicated in the User's Manual and located in the following positions for a left side impact (see Figures 3 thru 5 on following pages):

- A. Left Upper Rib (LUR)
- B. Left Lower Rib (LLR)
- C. Lower Spine (T_{12})
- D. Pelvis Assembly (PEV)

8. INSTRUMENTATION AND CALIBRATION REQUIREMENTS...Continued

NOTE: The neck, chest and pelvis are instrumented for the purpose of collecting additional information about the event. For right side impact, the rib accelerometers shall be installed on the right upper and lower ribs.

SID/HIII SCHEMATIC -- LEFT SIDE VIEW IN SITTING

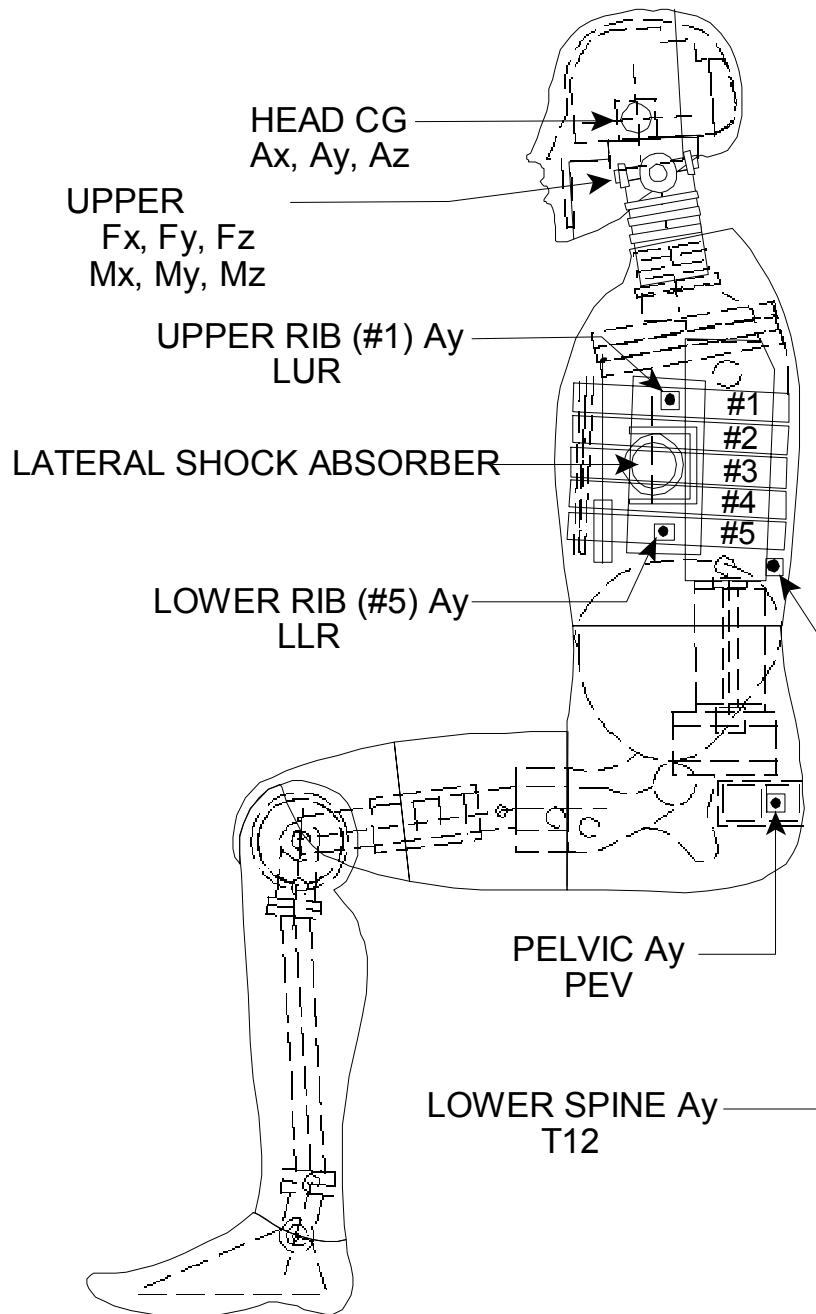

FIGURE 3

8. INSTRUMENTATION AND CALIBRATION REQUIREMENTS....Continued

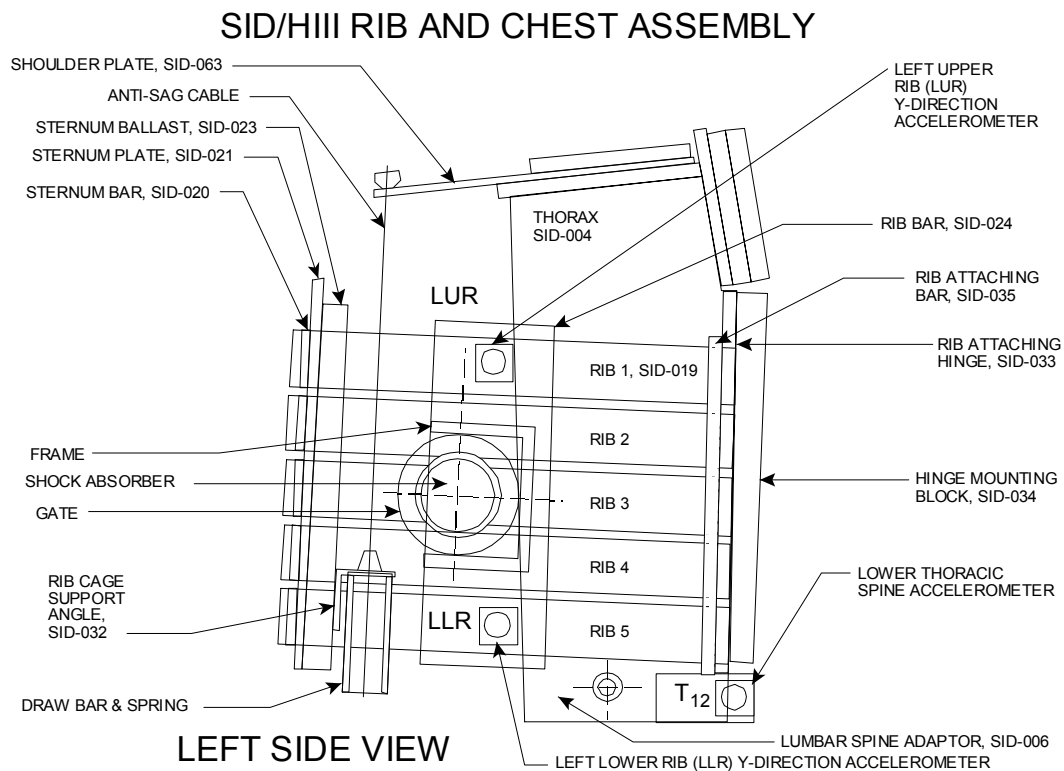

FIGURE 4

8. INSTRUMENTATION AND CALIBRATION REQUIREMENTS....Continued

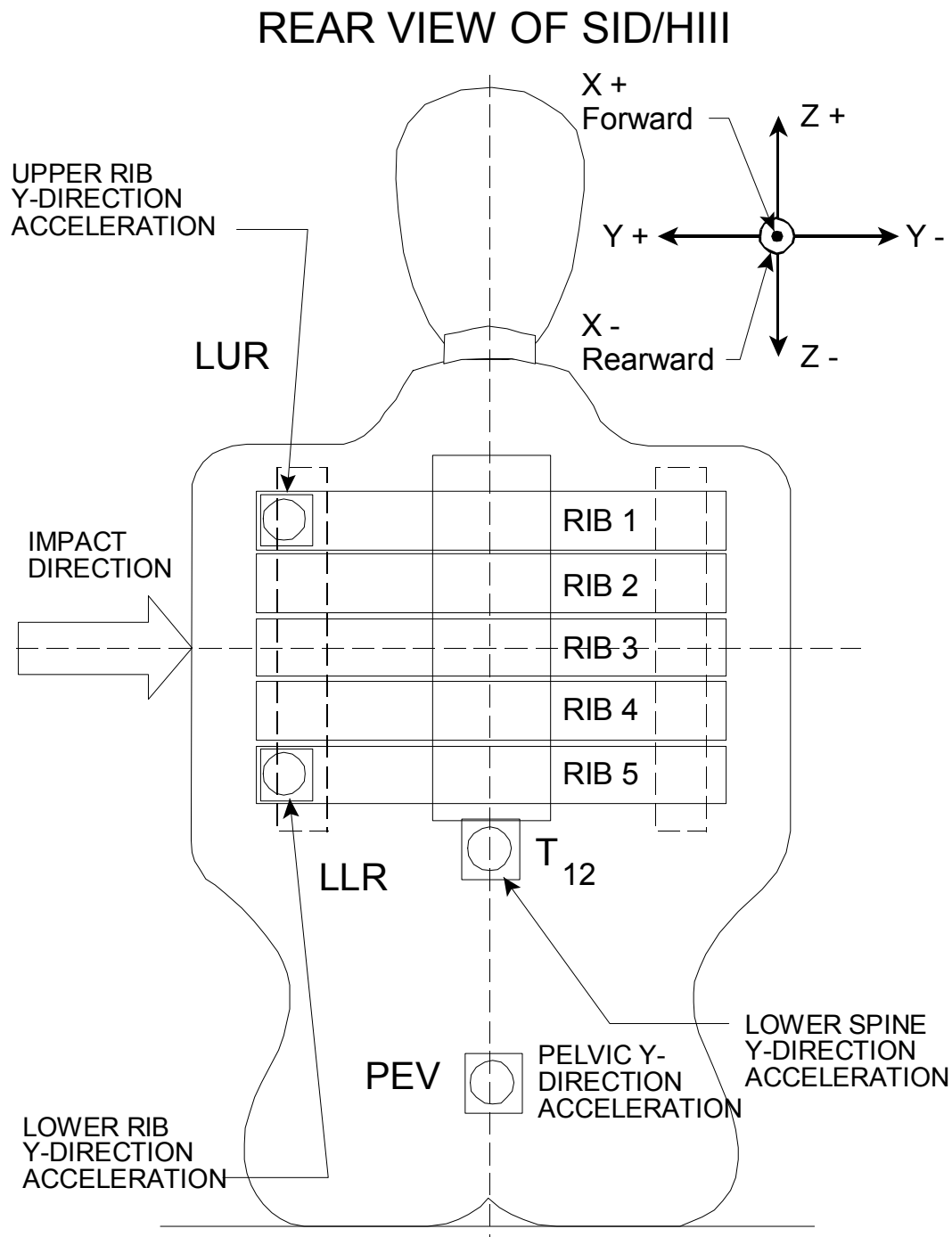

FIGURE 5

8. INSTRUMENTATION AND CALIBRATION REQUIREMENTS....Continued

8.3 SIDE IMPACT HYBRID DUMMY (SID/HIII) CALIBRATION

DUMMY CONFIGURATION AND PERFORMANCE VERIFICATION TESTING

All GFP Part 572(M) test dummies, SID/HIII, shall be calibrated (pre and post-test) by the contractor ON-SITE. The SID/HIII thorax and lumbar spine are to be calibrated based on Part 572(F), i.e. SID, requirements. The SID/HIII is to be calibrated based on the procedures as outlined in Appendix A — Laboratory Configuration and Performance Verification Procedure for Side Impact Hybrid Dummy.

The SID/HIII shall be clothed with form fitting cotton pants (above-the-knee to mid-calf length) and short sleeve shirts during the calibration test and also during the compliance test.

NOTE: The SID/HIII shock absorber shall be calibrated prior to initiating the test program. It is not necessary to calibrate the shock absorber after every impact, but it shall be calibrated after 5 exposures or in the event there is a problem with obtaining acceptable calibration data for the upper or lower ribs.

8.4 DRAWING LIST FOR SIDE IMPACT HYBRID DUMMY (SID/HIII)

In addition to the Part 572(B) part drawings, the Part 572(M) SID/HIII drawings include the Part 572(E) and Part 572 (F) part drawings:

PART 572(E), HIII, DRAWINGS

78051-61X Rev. C	- Head Assembly
78051-383 Rev. P	- 6-Axis Transducer Structural Replacement
C1709	- 6-Axis Transducer
78051-339	- Head-Neck Pivot Pin
78051-90 Rev. A	- Neck Assembly
78051-307 Rev. X	- Upper Neck Bracket*
78051-303 Rev. E	- Lower Neck Bracket*

* Lateral Neck Calibration Only

8. INSTRUMENTATION AND CALIBRATION REQUIREMENTS....Continued

PART 572(F), SID, DRAWINGS

SID-002 -	Lumbar (Molded)
SID-003 -	Lumbar Flange
SID-004 -	Thoracic Assembly
SID-005 -	Thorax to Lumbar Adaptor Assembly
SID-006 -	Lumbar Adaptor
SID-007 -	Thorax Assembly Bottom Plate
SID-008 -	Thorax Assembly Bottom Plate Locator
SID-009 -	Lower Thoracic Spine Accelerometer (T ₁₂) Mounting Platform
SID-010 -	Thorax Assembly Side Plate
SID-011 -	Thorax Assembly Front Block
SID-012 -	Thorax Assembly Back Block
SID-013 -	Thorax Assembly Top Plate
SID-014 -	Upper Thoracic Spine Accelerometer (T ₁) Base Plate
SID-015 -	Front Partition Plate – DELETED
SID-016 -	Rear Partition Plate – DELETED
SID-017 -	Side Plate Tapping Block – DELETED
SID-018 -	Side Impact Rib Assembly
SID-019 -	Side Impact Rib (Steel Portion)
SID-020 -	Sternum Center Bar
SID-021 -	Sternum Plate (Urethane)
SID-022 -	Top and Bottom Sternum Bar
SID-023 -	Sternum Ballast
SID-024 -	Rib Bar
SID-025 -	Front Rib Ballast
SID-026 -	Rear Rib Ballast
SID-027 -	Rib Bar Right Side Ballast
SID-028 -	Rib Bar Left Side Ballast
SID-029 -	Rib Ballast Cushion
SID-030 -	Rib Reinforcement
SID-031 -	Sternum Ballast Upper and Lower Washer Bar
SID-032 -	Rib Cage Support Angle
SID-033 -	Rib Attaching Hinge
SID-034 -	Hinge Mounting Block
SID-035 -	Rib Cage to Hinge Bar
SID-036 -	Upper Thoracic Spine Accelerometer (T ₁) Plate
SID-037 -	Upper Thoracic Spine Accelerometer (T ₁) Mount

8. INSTRUMENTATION AND CALIBRATION REQUIREMENTS....Continued

SID-038 -	Lower Thoracic Spine Accelerometer (T ₁₂) Mount
SID-039 -	Lower Thoracic Spine Accelerometer (T ₁₂) Cover
SID-040 -	Rib Wrap Assembly
SID-041 -	Outer Rib Pad
SID-042 -	Inner Rib Pad
SID-043 -	Rib Bar Washer Strip
SID-046 -	Anti-bottoming Pad Spacer – DELETED
SID-047 -	Rib Routing Tube – DELETED
SID-048 -	Upper Thoracic Spine Accelerometer (T ₁) Routing Tube – DELETED
SID-049 -	Lower Thoracic Spine Accelerometer (T ₁₂) Routing Tube – DELETED
SID-052 -	Lower Shoulder Foam
SID-053 -	Rib Cage General Layout
SID-054 -	Shock Absorber (Damper) Gate
SID-055 -	Shock Absorber (Damper) Pivot Pin
SID-056 -	Shock Absorber Mounting Frame
SID-057 -	Shock Absorber Support Angle
SID-058 -	Shock absorber Mount Nylon Washers
SID-059 -	Potentiometer Mounting Bracket and Ring – OPTIONAL
SID-060 -	Shock Absorber Cap and Rod End – DELETED
SID-061 -	Shock Absorber to Rib Bar Attaching Shaft and Spacer
SID-062 -	Shock Absorber to Rib Bar Attaching Clevis
SID-063 -	Shoulder Plate
SID-064 -	Rib Cage Support Details
SID-065 -	Outer Skin Zipper Assembly
SID-066 -	Outer Skin
SID-067 -	Front Zipper Assembly
SID-068 -	Rear Zipper Assembly
SID-069 -	Arm Foam
SID-070 -	Tapered Socket Head Bolt Listing
SID-071 -	Socket Head Bolt Listing
SID-072 -	Flat Head Socket Bolt Listing
SID-073 -	Machine Screw Listing
SID-074 -	Hex Nut Listing
SID-075 -	Washer Listing
SID-076 -	Lower Rib Bar Accelerometer Mount – DELETED

8. INSTRUMENTATION AND CALIBRATION REQUIREMENTS....Continued

SID-077 -	Shock Absorber Rod End
SID-078 -	Upper Knee Post
SID-079 -	Lower Knee Post
SID-081 -	DELETED
SID-082 -	DELETED
SID-083 -	Thoracic Shock Absorber Test Procedure and Specifications
SID-084 -	Rib Ballast Nut Plate
SID-085 -	Rib Bar Cushion
SID-086 -	DELETED
SID-087 -	Pelvis Structure and Flesh Assembly (2 Pages)
SID-088 -	Lumbar Pelvic Adaptor
SID-089 -	Linear Potentiometer – OPTIONAL
SID-090 -	SID Pelvic Accelerometer – Mount

ADDITIONAL PART 572(M), SID/HIII, DRAWINGS

96-SIDH3-001 -	Head-Neck Bracket Assembly
96-SIDH3-002 -	Head-Neck Bracket, Upper Base
96-SIDH3-003 -	Head-Neck Bracket, Support
96-SIDH3-004 -	Head-Neck Bracket, Lower Base
96-SIDH3-006 -	Shoulder Foam Pieces, Upper and Middle

8. INSTRUMENTATION AND CALIBRATION REQUIREMENTS...Continued

8.5 TEST VEHICLE INSTRUMENTATION

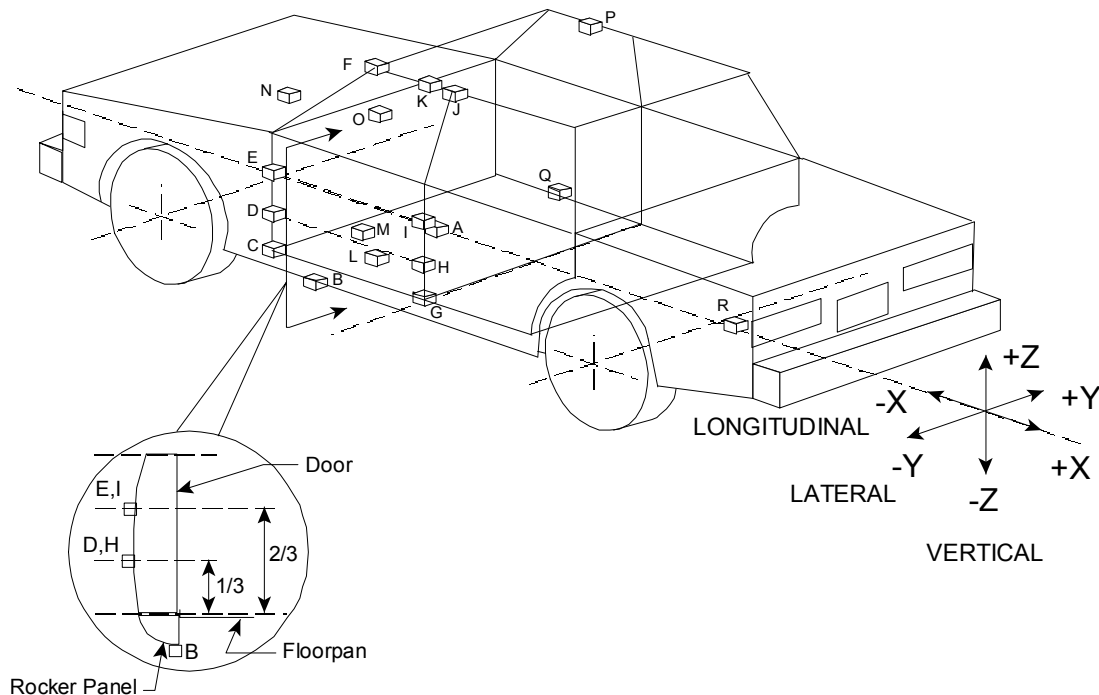

FIGURE 6

The following accelerometers shall be attached to the test vehicle;

NOTE: The COTR shall be consulted prior to accelerometer installation to determine if any unique characteristics of the advanced dynamic head impact system are compatible with the listed accelerometer locations.

- A. Vehicle CG: One triaxial or three uniaxial accelerometer(s) mounted to the floorpan at the longitudinal and lateral location of the vehicle CG to provide A_x , A_y and A_z data. Triaxial angular rate (deg/sec) sensor mounted at the longitudinal and lateral location of the vehicle CG to provide pitch, roll and yaw data.
- B. Left Floor Sill: Uniaxial accelerometer mounted on the impacted side sill forward of the impact line but rearward of the A pillar to provide A_y data.

8. INSTRUMENTATION AND CALIBRATION REQUIREMENTS....Continued

- C. A Pillar Sill: Uniaxial accelerometer mounted on the left A pillar at the lower sill level to measure Ay data.
- D. A Pillar Low: Uniaxial accelerometer mounted on the left A pillar (1/3 the distance from the floor to the bottom of the doors window opening) to measure Ay data.
- E. A Pillar Mid: Uniaxial accelerometer mounted on the left A pillar (2/3 the distance from the floor to the bottom of the doors window opening) to measure Ay data.
- F. A Pillar Upper: Uniaxial accelerometer mounted on the left A pillar at the joining point of the pillar and roof rail to measure Ay data.
- G. B Pillar Sill: Uniaxial accelerometer mounted on the left B pillar at the lower sill level to measure Ay data.
- H. B Pillar Low: Uniaxial accelerometer mounted on the left B pillar (1/3 the distance from the floor to the bottom of the doors window opening) to measure Ay data.
- I. B Pillar Mid: Uniaxial accelerometer mounted on the left B pillar (2/3 the distance from the floor to the bottom of the doors window opening) to measure Ay data.
- J. B Pillar Upper: Uniaxial accelerometer mounted on the left B pillar near the joining point of the pillar and roof rail to measure Ay data.
- K. Left Roof: Uniaxial accelerometer mounted on the left roof rail between the A and B pillars, rearward of the impact location but out of the way of the dummy's possible head contact areas to provide Ay data.
- L. Driver Seat: Uniaxial accelerometer mounted on the driver's seat track approximately aligned with the dummy's H-point to obtain Ay data.
- M. Driver Door: A minimum of 3 uniaxial accelerometers mounted on the driver door inner panel removed from the impact location to measure Ay data.

8. INSTRUMENTATION AND CALIBRATION REQUIREMENTS....Continued

- N. Engine: Biaxial accelerometer mounted on the top of the engine to measure Ax and Ay data.
- O. Firewall: Uniaxial accelerometer mounted on the center of the firewall to measure Ay data.
- P. Right Roof: Uniaxial accelerometer mounted on the passenger side roof rail in line with pole impact location to measure Ay data.
- Q. Right Floor Sill: Uniaxial accelerometer mounted on the passenger side floor sill in line with the pole impact location to measure Ay data.
- R. Rear Deck: Biaxial accelerometer mounted on the rear floorpan behind the rear axle laterally centered to measure Ax and Ay data.

The following instruments shall be attached to the rigid pole (if so equipped):

Six to eight load cells arranged in a vertical array.

8.6 IMPACT LINE MARKER

A permanent record of the actual impact line (vertical) shall be made by taping a cement tack or similar device to the center of the pole at a height coincident with the mid door (tape level 3). The horizontal impact line offset tolerance (at the time of first contact with the pole) shall be ± 38 mm.

8. INSTRUMENTATION AND CALIBRATION REQUIREMENTS...Continued

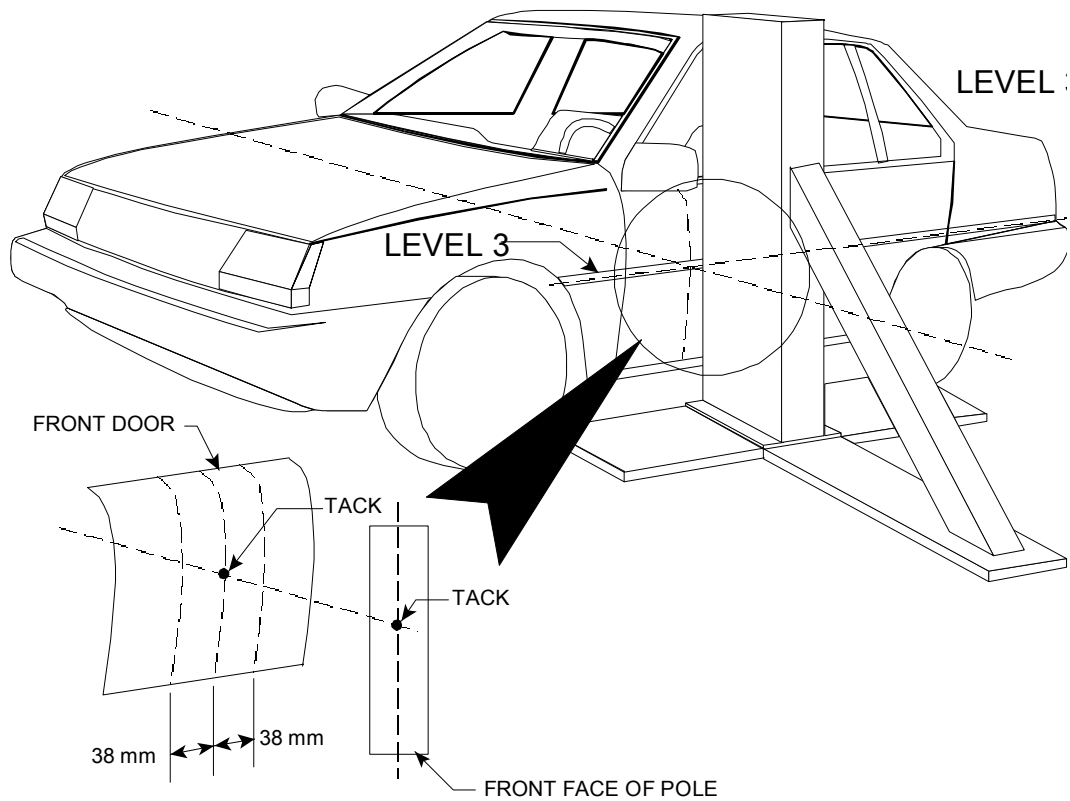

FIGURE 7

9. PHOTOGRAPHIC DOCUMENTATION

Each side impact test shall be documented on 16 mm color movie film at a minimum speed of 1000 frames-per-second (fps) except for the 24 fps real-time cameras. Glare or lights showing on any glass area (closed windows or vents) must be minimized so that views of the dummies during the test are visible for film analysis.

A timing mark must be registered on the film edge at least every 10 milliseconds (ms) and a time zero impact mark must be registered on the film to indicate when contact is made in order to permit vehicle and dummy kinematic analysis on a film analyzer.

9. PHOTOGRAPHIC DOCUMENTATION....Continued

The vehicle interior may require auxiliary on-board lighting to ensure adequate film exposure.

The contractor shall report the locations of all cameras along with camera speeds and lens focal lengths on the appropriate final report data sheet. Camera locations shall be referenced to the most forward edge of the pole along the pole's X axis with the X, Y and Z coordinates of the lens recorded for each camera.

9.1 GROUND BASED CAMERAS REQUIRED

- Camera 1 high-speed overhead camera to view the entire target vehicle and positioned directly above the forward edge of the pole.
- Camera 2 high-speed overhead camera to provide closeup view of the impact (should include view of photo targets on centerline of test vehicle and photo targets on top of the pole) and positioned adjacent to Camera 1.
- Camera 3 high-speed camera positioned 45 deg. to the left side of the test vehicle viewing the impact area to the rear of the pole.
- Camera 4 high-speed camera positioned 45 deg. to the left side of the test vehicle viewing the impact area forward of the pole.
- Camera 5 real-time (24 fps) camera to provide pretest, test, and post test coverage.
- Camera 6 high-speed camera positioned along the pole's longitudinal axis to the rear of the pole.
- Camera 7 high-speed camera positioned 90 deg to the pole's longitudinal axis viewing the front end of the test vehicle at impact.
- Camera 8 high-speed camera positioned 90 deg to the pole's longitudinal axis with a view of the front vertical roof targets and the test vehicle at impact (25—35 mm lens).

9. PHOTOGRAPHIC DOCUMENTATION...Continued

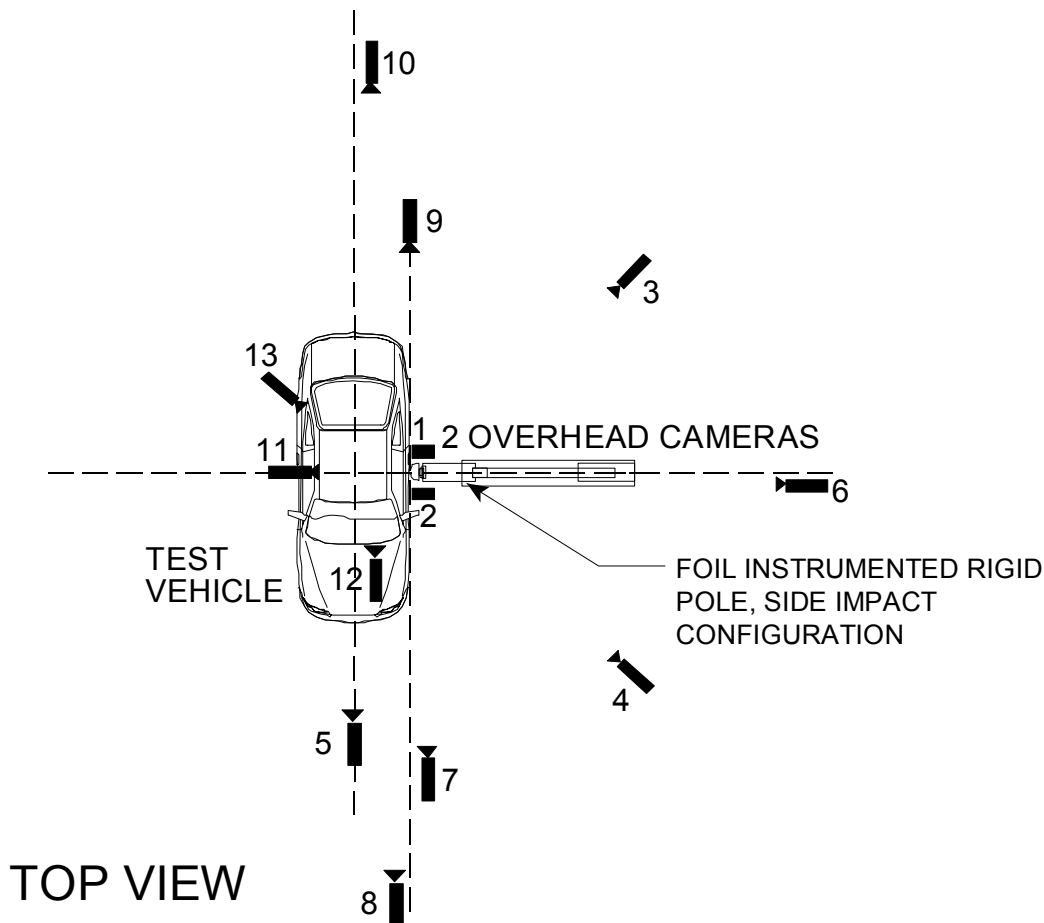

FIGURE 8

Camera 9 high-speed camera positioned 90 deg to the pole's longitudinal axis viewing the rear end of the test vehicle at impact.

Camera 10 high-speed camera positioned 90 deg to the pole's longitudinal axis with a view of the rear vertical roof targets and the test vehicle at impact.

9.2 TEST VEHICLE ONBOARD CAMERAS REQUIRED

Camera 11 high-speed camera to provide right side view of the front SID/HIII through the vehicle's front passenger window.

Camera 12 high-speed camera to provide a front view of the front SID/HIII.

Camera 13 high-speed camera to provide right side rear view of the front SID/HIII through vehicle's rear passenger window.

9. PHOTOGRAPHIC DOCUMENTATION....Continued

9.3 COLORING REQUIREMENTS FOR PHOTOGRAPHIC PURPOSES

- A. Vehicle interior surfaces such as the A, B, C-pillars and trim panels, interior door trim panels, etc., on the impact side of the vehicle shall be painted with flat white paint. The area around surfaces where the air bag or dynamic system deploys shall **NOT** be painted. In addition, the air bag or dynamic system indicator light on the instrument panel shall **NOT** be painted so as to be visible prior to testing.
- B. Parts of the anthropomorphic test device shall be coated with colored chalk/water solutions to show contact points with the vehicle's door and interior components. The chalk/water solution shall be applied after final dummy positioning.

CHALK COLORS TO BE USED ON TEST DUMMIES

DUMMY PART	DRIVER
Face	Blue
Top of Head	Yellow
Left Side of Head	Green
Back of Head	Red
Left Hip	Red
Left Shoulder	Orange

9.4 VEHICLE AND DUMMY PHOTOGRAPHIC COVERAGE (REAL-TIME)

The real-time camera (24 fps) shall be used to document the pretest and post test condition of the test vehicle and pole in addition to the pretest and post test positions of the test dummy including but not limited to the placement of the lap and shoulder belt on the dummy.

9. PHOTOGRAPHIC DOCUMENTATION....Continued

9.5 IMPACT EVENT MARKERS

It is strongly recommended that in-camera light emitting diodes (LEDS) be used to record the side impact event time zero point. If this is not possible, strobe lights or taped flash bulbs shall be placed in the field-of-view of all twelve high-speed cameras to mark the time zero point. The contractor shall use pressure switches attached to the test vehicle or pole impact face in order to trigger the time zero indicators.

9.6 PHOTOGRAPHIC TARGETS AND TAPE FOR TEST VEHICLE

PHOTOGRAPHIC TARGETS AND TAPE FOR RIGID POLE AND TEST VEHICLE

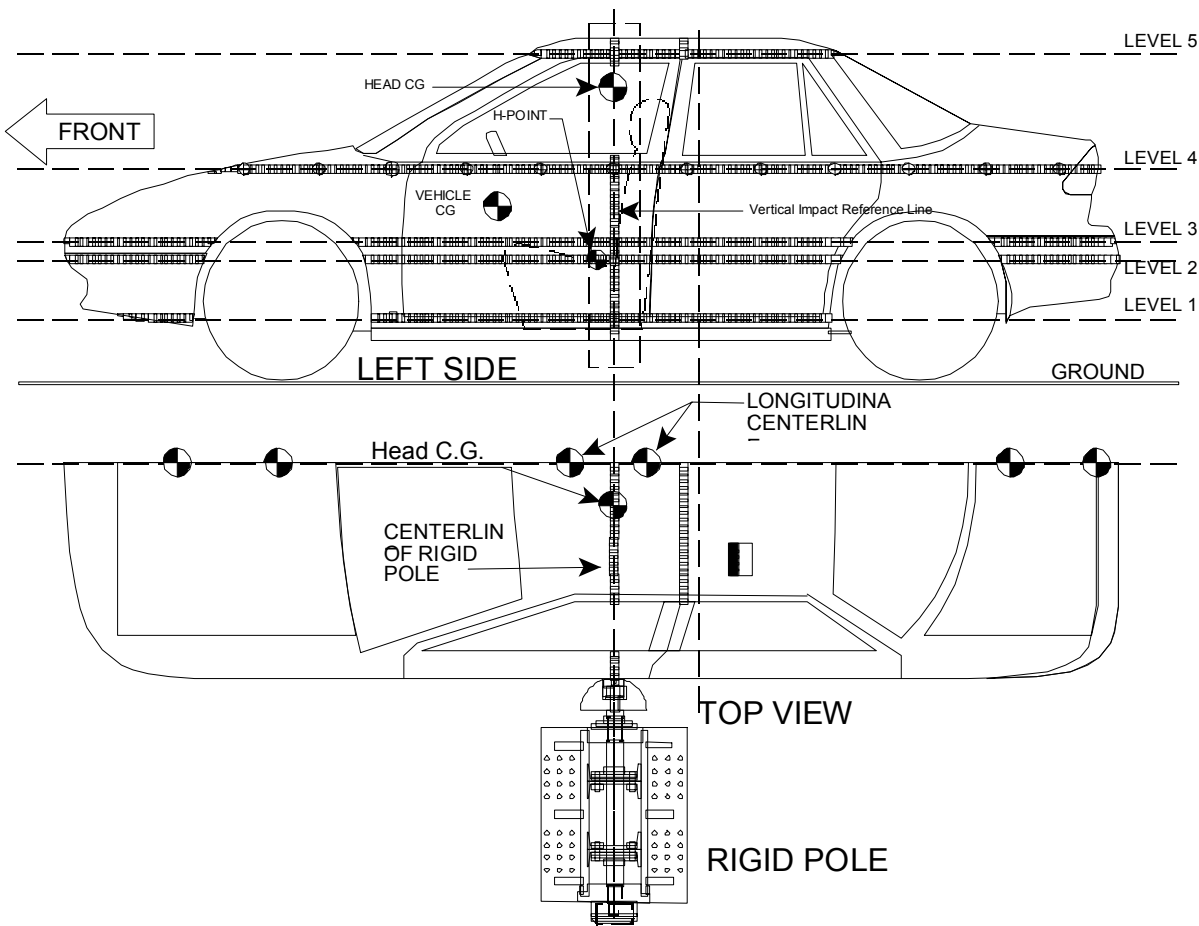

FIGURE 9

9. PHOTOGRAPHIC DOCUMENTATION....Continued

A. Twenty-five millimeter (25 mm) wide yellow/black checkerboard tape shall be placed along the struck side of the test vehicle at the following five levels above the ground surface –

- (1) LEVEL 1 – side sill top height
- (2) LEVEL 2 – occupant H-Point height
- (3) LEVEL 3 – mid-door height (midpoint of distance from the bottom of the windowsill to bottom of door).
- (4) LEVEL 4 – window sill height
- (5) LEVEL 5 – top of window height

In addition, the target tape shall be placed vertically on the struck side of the vehicle coincident with the pole impact location. On the top of the vehicle, place target tape down the longitudinal centerline of the entire vehicle (excluding glazing surfaces). Also, place target tape laterally across the roof of the vehicle in two locations 90 deg. to the centerline tape. First, in-line with the pole impact location, second, in-line with the left B pillar. On the front of the vehicle, place target tape in the lateral direction either on the bumper on another surface that is nearly planar (vehicle YZ). On the pole apparatus, place two strips of target tape vertically along the sides of the pole just behind the cylindrical impact faces.

B. Photographic targets (100 mm diameter) shall be placed on the vehicle and pole as follows:

- (1) the driver door to denote the vehicle CG location,
- (2) the roof to mark the head CG location,
- (3) 2 targets on the roof aligned with the longitudinal centerline exactly 760 mm (30 in.) apart (center to center) centered on rigid pole centerline,

9. PHOTOGRAPHIC DOCUMENTATION....Continued

- (4) 2 vertical targets 610 mm (24 in.) apart rear of the B-pillar centered about the longitudinal centerline,
- (5) 2 targets on the hood aligned with the longitudinal centerline exactly 610 mm (24 in.) apart (center to center),
- (6) 2 targets on the trunk aligned with the longitudinal centerline exactly 305 mm (12 in.) apart (center to center),
- (7) on the top of the pole behind the cylindrical impact masses.

If the roof/hood/trunk surface(s) is too short to accommodate the recommended placements of the photographic targets 3-6, the COTR shall determine the separation distances.

9.7 TARGET VEHICLE INFORMATION PLACARDS

Test vehicle identification placards shall be positioned so that at least one placard will be visible in each of the 10 camera's field of view. The following information shall be shown:

- A. Target vehicle's NHTSA number
- B. The words "Rigid Pole Side Impact", FMVSS 201
- C. Date of the side impact test
- D. Name of contract laboratory
- E. Vehicle year, make and model

9.8 CRASH FILM TITLE HEADING & SEQUENCE

The contractor shall submit 3 copies of the 16mm color movie film for each crash test two weeks from the date of the vehicle crash test. The master print for each of the crash test films shall be retained by the contractor, but will be made available to the NHTSA upon request.

9. PHOTOGRAPHIC DOCUMENTATION....Continued

The 16 mm color test movie film shall include the following title frames:

- A. The following Rigid Side Impact Test was conducted under the contract with the National Highway Traffic Safety Administration by (laboratory name, city, state).
- B. Rigid Pole Side Impact at x.x km/hr - FMVSS 201
Test Vehicle Model Year, Make and Model
NHTSA No. XXXXXX
Date of Impact Event
Contract No.: DTNH22-XX-X-XXXXX
- C. The ending frame shall state "THE END".

The film shall be edited in the following sequence:

- A. Title
- B. Pretest Coverage
- C. Real Time Pan Coverage
- D. All high speed coverage
- E. Post test Coverage
- F. Any vehicle failures or anomalies.
- G. "The End"

9.9 STILL PHOTOGRAPHS

Photographs shall be color, 203 mm x 254 mm (8 in. x 10 in.), and be clear and sharp. A tag, label or placard identifying the test vehicle model, NHTSA number, and test date shall appear in each photograph and be legible. Each photograph shall be labeled as to subject matter. As a minimum the following photographs shall be included:

- A. Pretest and post test frontal views of the target vehicle
- B. Pretest and post test rear views of the target vehicle
- C. Pretest and post test side views of the struck side of the vehicle showing initial impact line longitudinally and vertically on the target vehicle

9. PHOTOGRAPHIC DOCUMENTATION....Continued

- D. Pretest and post test occupant compartment views showing the SID/HIII positions and the available clearance between the dummy and the struck door, as well as positions of belt restraints (photographs with door closed and with door open)
- E. Post test close-up view of impact zone
- F. Pretest views of dynamic system
- G. Post test views of the deployed dynamic system, head impact location marks
- H. Pretest and post test views of front inner door panel
- I. Pretest and post test views of rear inner door panel
- J. Post test overhead view of impact location
- K. Pretest shots of all vehicle mounted sensors
- L. Post test views of damaged interior components such as the dashboard, seats, and steering wheel/column, upper interior
- M. Closeup view of vehicle's certification label
- N. Closeup view of vehicle's tire information placard or label

9.10 VEHICLE MEASUREMENTS

A. EXTERIOR PROFILE MEASUREMENTS (SIDE CRUSH)

Prior to the test (with the test vehicle in the "as tested" configuration) exterior profile measurements of the impact side of the vehicle shall be made. These (pretest and post test) measurements are to be made at all five levels across the entire length of the vehicle at 75 mm intervals between the A and B pillars, and at 150 mm intervals elsewhere as shown in Figure 10. These lateral measurements are made from a reference plane which is parallel to the test vehicle's longitudinal centerline.

9. PHOTOGRAPHIC DOCUMENTATION....Continued

NOTE: The post test measurements shall begin at the first 150 mm mark forward of forwardmost point of the induced damage and end at the first (150 mm) mark past the rearwardmost point of the induced damage. Measurements shall be made to the same targets used for the pretest measurements (these will not necessarily be every 75 mm after the test).

PRETEST AND POST TEST EXTERIOR PROFILE MEASUREMENTS

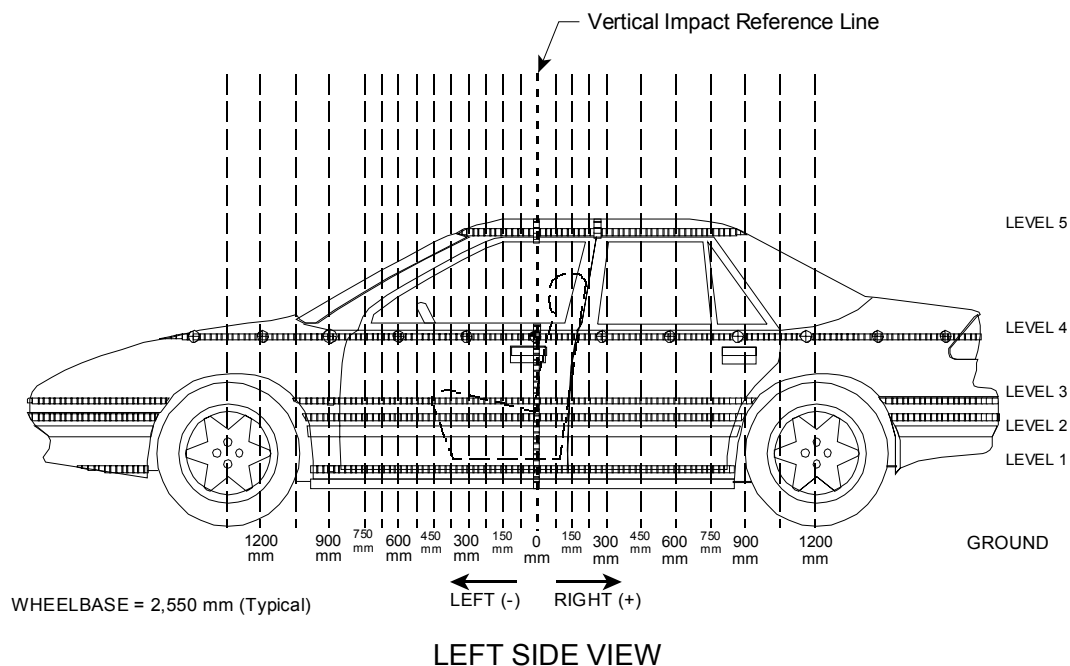

FIGURE 10

B. TEST VEHICLE INSTRUMENTATION LOCATION & MEASUREMENTS

Pretest and post test measurements of all the vehicle accelerometer/sensor locations should be taken. A point on the vehicle that will not experience significant relative displacement, such as the vehicle CG or right side (for a left side impact) lower sill, should be chosen as the reference point for the measurements.

C. STRUCK SIDE DIMENSIONS

Pretest and post test dimensional measurements of the struck side of the vehicle should be recorded on the appropriate data sheet(s). The vehicle must be in the "as tested" configuration.

9. PHOTOGRAPHIC DOCUMENTATION....Continued

NOTE: All measurements should be accurate to within ± 3 mm. In the case of post test sensor location measurements, this may not always be possible, but every effort should be made to collect as accurate results as possible.

10. DEFINITIONS

CURB WEIGHT

The weight of a vehicle with standard equipment; maximum capacity of engine fuel, oil, coolant; and, if so equipped, air conditioning and additional weight optional engine.

DESIGNATED SEATING CAPACITY (DSC)

The number of designated seating positions provided as found on the tire information placard (required for passenger cars by FMVSS 110). This number must be consistent with the number of restraints in the vehicle.

DESIGNATED SEATING POSITION (DSP)

Any plan view location capable of accommodating a person at least as large as a 5th percentile adult female, if the overall seat configuration and design and vehicle design is such that the position is likely to be used as a seating position while the vehicle is in motion, except for auxiliary seating accommodations such as temporary or folding jump seats. Any bench or split-bench seat in a passenger car, truck or multipurpose passenger vehicle with a GVWR less than 10,000 pounds, having greater than 1270 mm of hip room (measured in accordance with SAE Standard J 1100(a)) shall not have less than three designated seating positions, unless the seat design or vehicle design is such that the center position cannot be used for seating.

DYNAMICALLY DEPLOYED INTERIOR HEAD PROTECTION SYSTEM

A protective device or devices which are integrated into a vehicle and which, when activated by an impact, provides, through means requiring no action from occupants, protection against head impacts with interior structures and components of the vehicle in crashes.

10. DEFINITIONS....Continued

H-POINT

The mechanically hinged hip point of a manikin which simulates the actual pivot center of the human torso and thigh, described in SAE Recommended Practice J826, "Manikin for Use in Defining Vehicle Seating Accommodations," May 1987.

SIDE IMPACT HYBRID DUMMY (SID/HIII)

The SID/HIII is identical in many respects to the existing P572 Subpart F test dummy used in FMVSS 214 except that the SID head and neck have been replaced with the P572 Subpart E head and neck assembly including a modified head-neck bracket assembly. The thorax and pelvis have been designed to produce human-like acceleration responses in the lateral direction. Also, the dummy has provision to mount accelerometers on the ribs, spine and pelvis; a shock absorber between the ribcage and the spine; and a hinge where the ribs attach to the spine. The SID/HIII does not have articulating arms or shoulders. Instead, the mass of the arms has been incorporated into the mass of the thorax, and urethane foam arms have been added for the appropriate biofidelity characteristics.

UNLOADED VEHICLE WEIGHT (UVW)

The weight of a vehicle with maximum capacity of all fluids necessary for operation of the vehicle, but **WITHOUT** cargo or occupants.

11. TEST EXECUTION

11.1 TEST VEHICLE PREPARATION

A. VEHICLE TEST WEIGHT

AS DELIVERED

After the test vehicle is received, fluids will be added to 100% capacity and the vehicle weight recorded to determine the "Unloaded Vehicle Weight" (UVW).

11. TEST EXECUTION....Continued

NOTE: The scales used to weigh the test vehicle shall be accurate to within 0.1%.

RATED CARGO AND LUGGAGE WEIGHT

FMVSS 110 requires that the Vehicle Capacity Weight (VCW) and the Designated Seating Capacity (DSC) be recorded on the tire information placard for passenger cars. This information can be used to determine the "Rated Cargo and Luggage Weight" (RCLW) as follows:

$$\text{RCLW} = \text{VCW} - (68 \text{ kg} \times \text{DSC})$$

Where the VCW is not provided on the label (for a multipurpose passenger vehicle, truck, or bus) it can be calculated by the following formula:

$$\text{VCW} = \text{Gross Vehicle Weight} - \text{UVW}$$

FULLY LOADED (CALCULATED TEST VEHICLE TARGET WEIGHT)

The fully loaded condition is the vehicle loaded to its UVW, plus the vehicle's RCLW (or 136 kg (300 lb), whichever is less) located along the vehicle's longitudinal centerline in the luggage compartment, plus the weight of the necessary fully instrumented SID/HIII, placed in the test configuration.

The calculated Test Vehicle Target Weight (TVTW) [fully loaded test weight] is computed as follows:

$$\text{TVTW} = \text{UVW} + \text{RCLW} + (\text{weight of instrumented SID/HIII})$$

NOTE: A SID/HIII shall be placed in the front outboard seating position on the struck side of the vehicle for a dynamic head impact protection system.

11. TEST EXECUTION....Continued

AS TESTED VEHICLE WEIGHT

Drain the fuel system and operate the engine until the fuel system is dry. Slowly refill the entire fuel system (rotate engine) with Stoddard solvent which has been dyed purple, having the physical and chemical properties of Type 1 solvent or cleaning fluid, Table 1, ASTM Standard D484-71, "Standard Specifications for Hydrocarbon Dry-cleaning Solvents" until, not less than 92 percent and not more than 94 percent, of the vehicle manufacturer's stated "usable capacity" is reached (use the useable capacity supplied by manufacturer, do not use values in the owners manual). This volume will be furnished by the COTR. The Stoddard solvent must be filtered while being introduced into the fuel system. Drain all other fluids from the test vehicle with the exception of brake fluid if required for abort system, so that Stoddard solvent leakage from the fuel system will be evident. Just prior to the test, operate the engine to assure that Stoddard solvent is present throughout the entire fuel system.

NOTE: It is permissible to cut small holes in coolant hoses and transmission torque converters to assure that all fluid other than Stoddard solvent has been removed from the vehicle.

Load the vehicle with the required instrumented test dummies and necessary on-board test equipment (including all instrumentation boxes, cameras, lighting, etc.) and then add ballast, if necessary, to achieve the Test Vehicle Target Weight. Weigh the vehicle again and record this weight as the **actual** Test Vehicle Weight (TVW).

The **Actual** Test Vehicle Weight (TVW) shall have the following boundaries;

(Calculated TVTW - 4.5 kg.) \$ Actual TVW \$ (Calculated TVTW - 9 kg.)

If the Calculated Test Vehicle Target Weight (TVTW) is exceeded, the contractor must notify the COTR to discuss the possible removal of vehicle components or instrumentation which would decrease the weight.

NOTE: Under no circumstances shall the actual vehicle test weight be greater than the Test Vehicle Target Weight (TVTW).

11. TEST EXECUTION....Continued

B. VEHICLE ATTITUDE (INCLUDING PITCH AND ROLL ANGLES)

When the vehicle is in its "as delivered," "fully loaded" and "as tested" condition, locate the vehicle on a flat, horizontal surface to determine the vehicle attitude. Determine using the same level surface or reference plane and the same standard points on the test vehicle for the "as delivered," "fully loaded" and "as tested" condition.

Measure the angles relative to a horizontal plane, front-to-rear and from left to right for the "as delivered," "fully loaded" and "as tested" conditions. The front-to-rear angle (pitch) shall be measured along a fixed reference on the driver's and passenger's door sill. Mark where the angles are taken on the door sill. The left to right angle (roll) shall be measured along a fixed reference point on the front and rear bumpers at the vehicle longitudinal centerline. Mark where the angles are measured.

The vehicle "as tested" pitch and roll angles shall be between the "as delivered" and "fully loaded" condition, inclusive.

C. TEST TEMPERATURE CONDITIONS

The Contractor must verify that the dummy temperature is in the specified temperature range (20.6EC - 22.2EC). The dummies must be soaked in an ambient air environment in the specified temperature range for 16 hours prior to test conduct. The ambient air temperature must be monitored and continuously recorded within 915 mm (36") of the dummies. The temperature sensor(s) shall be accurate to at least within ± 0.1 EC.

The Contractor shall mark the ambient air temperature recording with the date, time and technician's name at the beginning of the 16 hour soak and when the vehicle begins to move toward the pole. Any excursions from the specified temperature must be noted on the recording along with the reason for the excursion. Minor ($\pm .5$ EC) temperature fluctuations (above or below the specified 20.6EC to 22.2EC) are acceptable if they last less than a cumulative of 5 minutes. Temperature recordings shall be supplied to the COTR with final test reports.

11. TEST EXECUTION....Continued

D. ADDITIONAL PRETEST VEHICLE SETUP

- (1) Adjustable seats (on impact and nonimpact side) are placed in the adjustment position midway between the forward most and rearmost positions, and then if separately adjustable in a vertical direction, are adjusted to the lowest position. If an adjustment position does not exist midway between the forward most and rearmost positions, the closest adjustment position to the rear of the midpoint is used. (i.e.; the seat will be moved more rearward.)
- (2) Place all adjustable seat backs in the manufacturer's nominal design riding position in the manner specified by the manufacturer. If the position is not specified, set the seat back at the first detent rearward of 25 degrees from the vertical (when seat is unoccupied). (Provided by COTR).
- (3) Place each adjustable head restraint in its highest adjustment position. Position adjustable lumbar supports so that they are set in their released, i.e., full back position.
- (4) Dummy Seating Procedure: The dummy shall be seated initially using the FMVSS 214 seating and positioning procedures as outlined in Appendix B.
- (5) Establish the rearmost point (pt A) of intersection of the rear surface of the SID/HIII head (in the midsagittal plane) and a horizontal plane passing through the head's center of gravity (See Figure 11). If this point is NOT at least 50 mm (measured along the head cg horizontal plane, perpendicular to the vehicle's longitudinal centerline) forward of the front door daylight opening (pt B) (door must be closed - measure to the forward most point of the door daylight opening, which may be part of the door trim), then adjust the SID/HIII position as follows:
 - (A) Adjust the seat back angle until the 50 mm clearance is achieved, up to a maximum of 5 degrees. Please consult the COTR for seat back angle measurement location (see Section D(2) above).

11. TEST EXECUTION....Continued

- (B) If the clearance cannot be established with the seat back angle adjustment alone, then the seat is moved forward from the mid-position until either the 50 mm clearance is achieved, the seat's full forward adjustment is reached, or until there is knee interference, whichever comes first.

NOTE: Upon moving the seat forward, the target H-point is moved from its initially specified horizontal and vertical location.

- (C) If the clearance cannot be established with the seat back angle and seat track adjustment of 5(A) and (B), then further adjust the seat back angle until the 50 mm clearance is achieved, or until the seat back is in its full upright locking position, whichever comes first.
 - (D) Record the final seat back angle, seat track position and H-point movement.
- (6) The test dummy shall be restrained using **ALL** available belt systems in all seating positions. Adjustable anchorages are placed in the mid adjustment position or if there is no mid position, the COTR will determine test position.
 - (7) Adjustable steering controls are adjusted so that the steering wheel hub is at the geometric center of the locus it describes when it is moved through its full range of driving positions. If there is no detent at this position the steering controls will be adjusted according to the manufacturer's instructions. **(Provided by COTR)**
 - (8) Any adjustable arm rests shall be tested in the retracted (up) position.
 - (9) The test vehicle tire pressures shall be as stated on the tire placard or label to determine the "as delivered" and "fully loaded" vehicle attitude. If the tires on the vehicle are not the same as those specified on the tire placard, the C.O.T.R. shall determine what tire pressure should be used.

11. TEST EXECUTION....Continued

- (10) All test vehicle doors, including any rear hatchback or tailgate, shall be fully closed and latched but **NOT LOCKED**. (S8.23)

NOTE: Instrument Panel telltales shall be checked just prior to test to ensure that all doors and hatches are closed.

- (11) All the test vehicle's side windows that are adjustable shall be fully **OPEN**. If so equipped, the test vehicle's sunroof shall be **CLOSED**.
- (12) Convertibles and open-body type vehicles have the top, if any, in place in the closed passenger compartment configuration.
- (13) The key shall be in the ignition and switched to the **"ON"** position.
- (14) Parking brakes shall be **ENGAGED**.
- (15) Manual transmissions shall be placed in **SECOND** gear.
- (16) Automatic transmissions shall be placed in **NEUTRAL**.
- (17) The compartment temperature of the test vehicle shall be maintained at 20.6EC to 22.2EC (69EF - 72EF) for a minimum of four hours prior to the test.
- (18) Onboard cameras may be removed (with approval of COTR) if there is a problem attaining the test weight of the vehicle. Instrumentation should be removed first if possible. If there is a problem attaining the vehicles test weight, the COTR may require the onboard instrumentation to be removed. This will entail the instrumentation to be flexible enough to record data outside of the vehicle via umbilical cables or other equivalent (as approved by the COTR) devices.

11. TEST EXECUTION...Continued

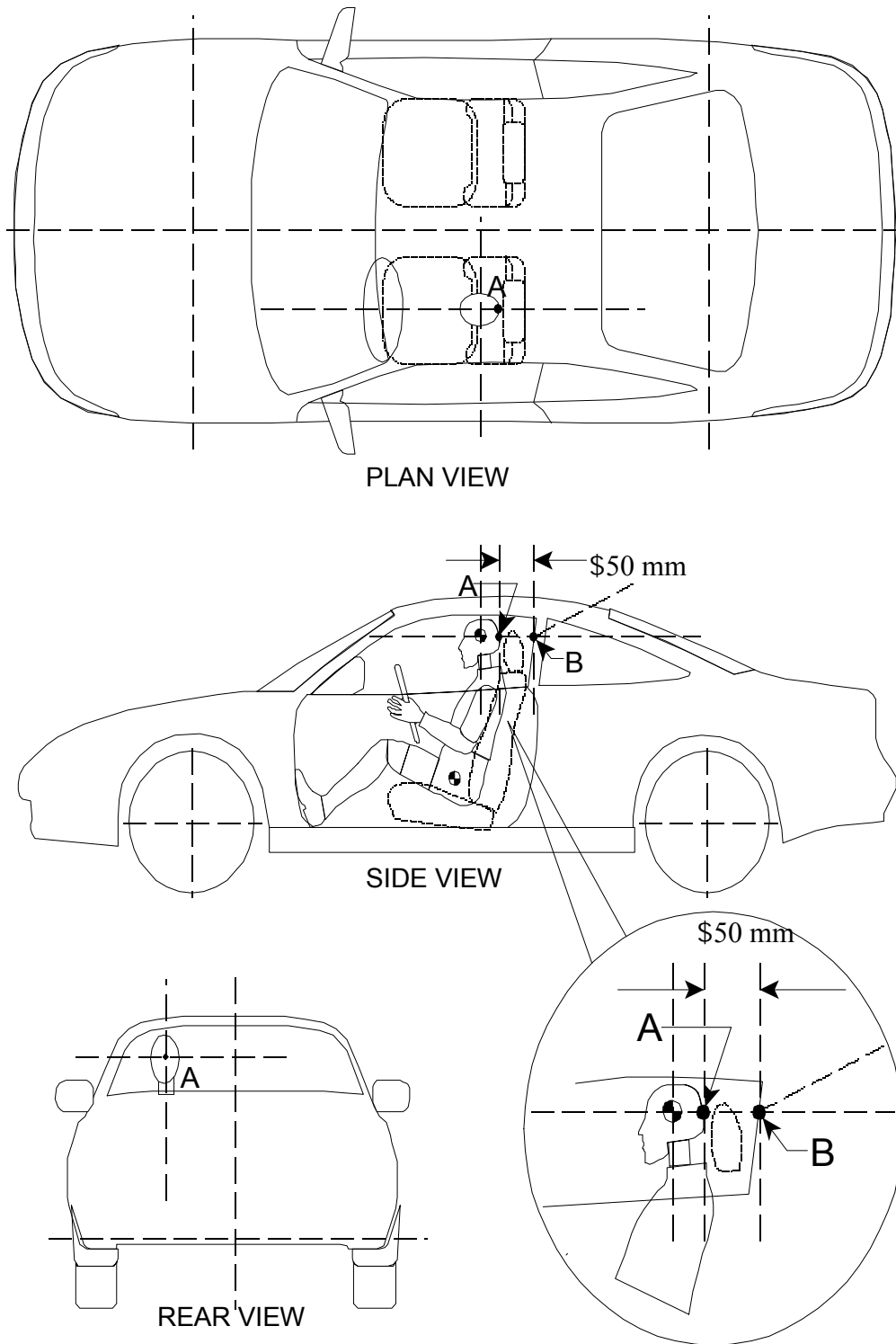

FIGURE 11

TEST EXECUTION....Continued

IMPACT REFERENCE LINE

A vertical impact reference line shall be established on the test vehicle at the intersection of the vertical transverse plane through the dummy head CG (front outboard designated seating position) and the vehicle exterior. The vertical impact reference line should be aligned with the centerline of the rigid pole such that the vehicle impacts the pole centerline within ± 38 mm (± 1.5 in) horizontally.

PHOTOGRAPHIC TARGETS AND TAPE FOR RIGID POLE AND TEST VEHICLE

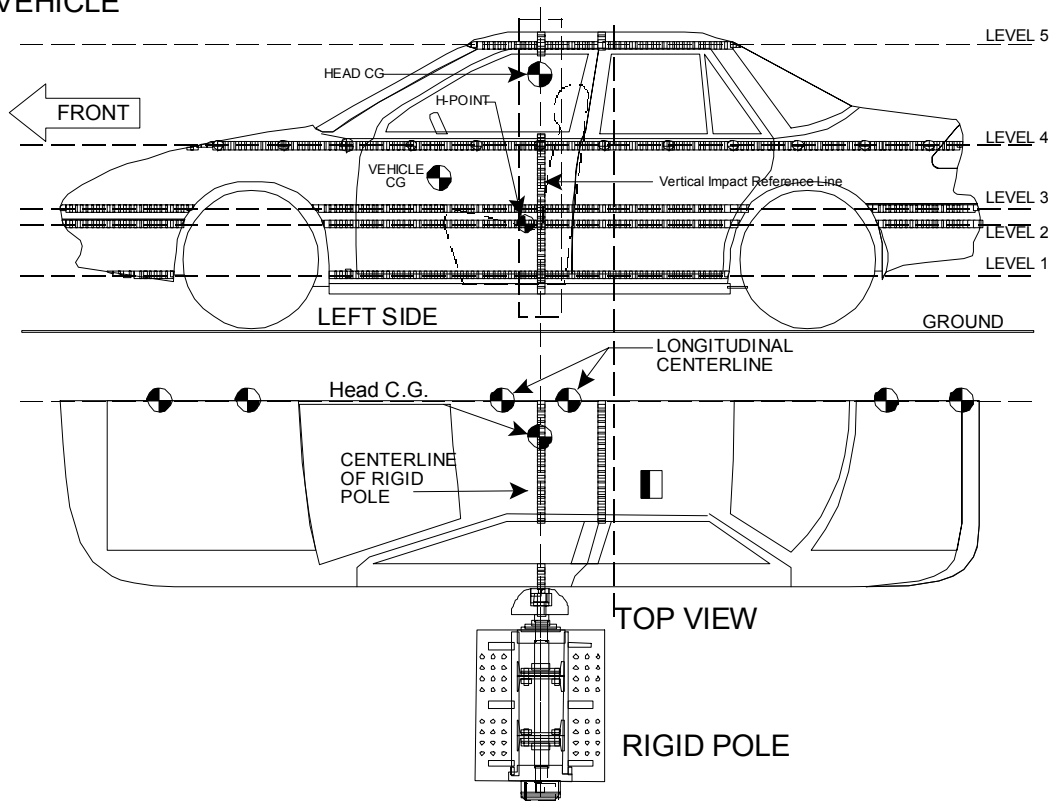

11. TEST EXECUTION...Continued

11.2 DUMMY PREPARATION, POSITIONING AND PLACEMENT

The stabilized temperature of the test dummy at the time of the side impact test shall be at any temperature between **20.6°C** and **22.2°C**. Each test dummy shall be clothed in form fitting cotton stretch garments with short sleeves and pants (above-the-knee to midcalf length). Each foot of the dummy shall be equipped with a size 11EEE shoe which meets the configuration, size, sole, and heel thickness specifications of MIL-S-13192 and weighs 0.48 kg to 0.66kg.

NOTE: In order to prevent permanent seat set, do NOT place the dummy in the test vehicle for overnight storage.

Initial dummy positioning procedures are detailed in Appendix B. Final positioning, if necessary (rear portion of head CG not 50 mm forward of front door daylight opening), shall be conducted in accordance with TP 201P - Section 11D (1 thru 5) The final positions of the driver dummy seated in the test vehicle shall be recorded by taking the following measurements (accurate to ± 3 mm);

SID/HIII LONGITUDINAL CLEARANCE DIMENSIONS (See Figure 13)

- *HH HEAD TO HEADER - taken from the point where the dummy's nose meets his forehead (between the eyes) to the furthest point forward on the header.
- *HW HEAD TO WINDSHIELD - taken from the point where the dummy's nose meets his forehead (between the eyes) to a point on the windshield. Use a level or plumb-bob.
- HZ HEAD TO ROOF - taken from the point where the dummy's nose meets his forehead (between the eyes) to the point on the roof directly above it. Use a level.
- *CS STEERING WHEEL TO CHEST - taken from the center of the steering wheel hub to the dummy's chest. Use a level.

11. TEST EXECUTION....Continued

- *CD CHEST TO DASH - place a tape measure on the tip of the driver dummy's chin and rotate 125 mm of it downward toward the dummy to the point of contact on the transverse center of the dummy's chest. Then measure from this point to the closest point on the dashboard either between the upper part of the steering wheel between the hub and the rim, or measure to the dashboard placing the tape measure above the rim, whichever is a shorter measurement.

- NR NOSE TO RIM - taken from the tip of the driver dummy's nose to the closest point on the top of the steering wheel rim

- KDL LEFT AND RIGHT KNEES TO DASHBOARD - taken from the center of the knee pivot

- /KDR bolt's outer surface to the closest point forward acquired by swinging the tape measure in continually larger arcs until it contacts the dashboard. Also reference the angle of this measurement with respect to the horizontal for the outboard knee (KDA).

- PHX H-POINT TO STRIKER(X) - locate a point on the striker; project this point (preferably, with a level) vertically downward; place tape measure on H-point and extend horizontally until it intersects level; record this measurement.

- PHZ H-POINT TO STRIKER(Z) - locate a point on the striker; project this point (preferably, with a level) horizontally toward the H-point; place tape measure on H-point and extend vertically until it intersects level; record this measurement.

- NOTE:** The B-pillar striker will be used as the reference point for PHX & PHZ measurements.

- *HB HEAD TO CENTER PILLAR - Locate the horizontal plane passing through the dummy head center of gravity. Identify the rearmost point on the dummy head in that plane. Construct a line in the plane that contains the rearward point of the front door daylight opening and is perpendicular to the longitudinal vehicle centerline. Measure the longitudinal distance between the rearmost point on the dummy head and this line.

11. TEST EXECUTION....Continued

SID/HIII LATERAL CLEARANCE DIMENSIONS (See Figure 14)

- *HR HEAD TO SIDE HEADER - measure the shortest distance from the point where the dummy's nose meets his forehead (between the eyes) to the side edge of the header just above the window frame, directly adjacent to the dummy.
- *HS HEAD TO SIDE WINDOW - taken from the point where the dummy's nose meets his forehead (between the eyes) to the outside of the side window. In order to make this measurement, roll the window down to the exact height which allows a level measurement. Use a level.
- *AD ARM TO DOOR - taken from the center of the bottom of the arm segment where it meets the dummy's torso to the closest point on the door
- *HD H-POINT TO DOOR - taken from the H-point on the dummy to the closest point on the door. Use a level.

11. TEST EXECUTION....Continued

SID/HIII DUMMY LONGITUDINAL MEASUREMENTS

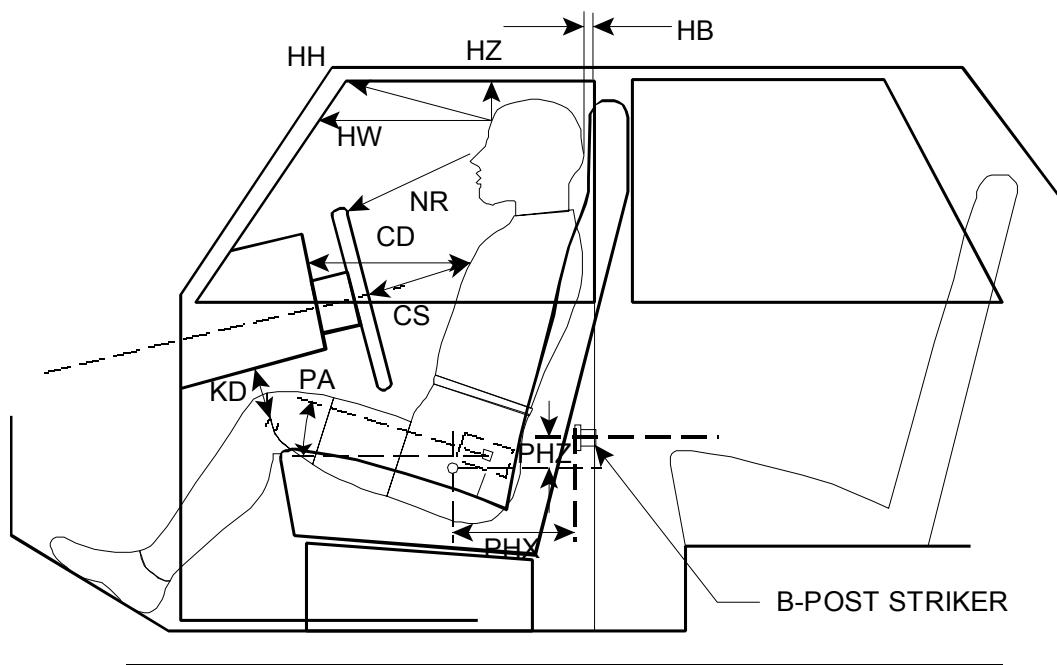

LEFT SIDE VIEW

FIGURE 13

11. TEST EXECUTION....Continued

ANGLES

SA SEAT BACK ANGLE - initially measured using the instructions provided by the manufacturer on **Form 2 – Manufacturer Supplied Information**; If no information is supplied, place adjustable seat backs at the first detent rearward of 25 degrees from the vertical.

Note: If supplemental seating procedure used, record seat back angle actually used.

PA PELVIC ANGLE - taken by inserting the pelvic angle gauge into the H-point gauging hole on the SID/HIII and taking this angle with respect to the horizontal;

When a level is to be used, it is to ensure that the line containing the two points described is either parallel or perpendicular to the ground. If a measurement to be made is less than 250 mm ignore the directions to use a level and approximate a level measurement. Also, when a measurement is to be taken to or from the center of a bolt on the dummy, take the measurement from the center of the bolt hole if the bolt is recessed.

* Measurement used in Data Tape Reference Guide

SID/HIII SIDE IMPACT TEST CONDITION

- A. The impact speed shall be 28.0 kph \pm 0.9 kph for compliance purposes.
- B. The longitudinal impact tolerance is \pm 38 mm (between the pole centerline and test vehicle's impact reference line).

11. TEST EXECUTION...Continued

SID/HIII DUMMY LATERAL
CLEARANCE MEASUREMENTS

FIGURE 14

12. TEST DATA

The contractor shall make all preliminary test data available to the COTR on location within two hours after the test. Final test data, including digital printouts and computer generated plots, shall be furnished to the COTR within five working days. Additionally, the contractor shall analyze the preliminary test results as directed by the COTR.

12.1 PERFORMANCE REQUIREMENTS

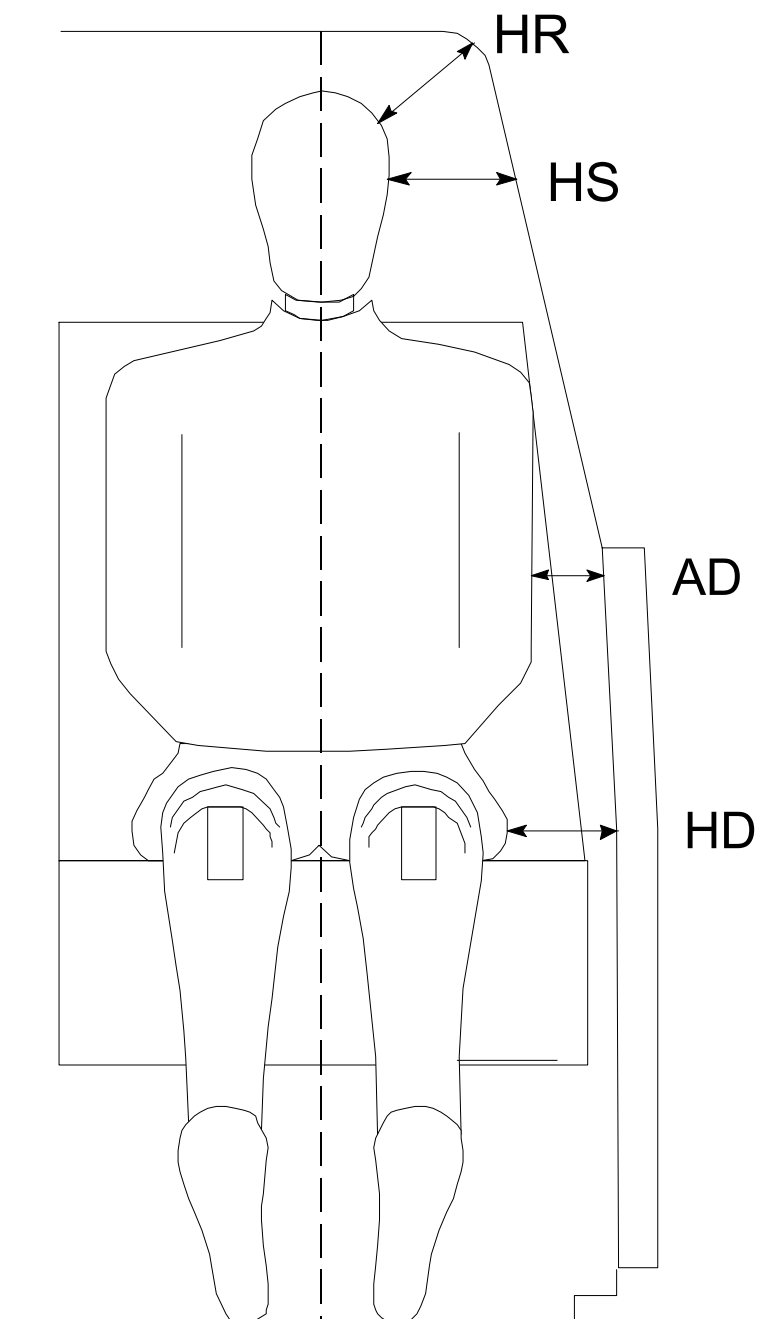
The side impact hybrid dummy (SID/HIII) shall be used for testing and will be located in the front designated seating position on the struck side of the target vehicle. The SID/HIII will be instrumented to measure head CG triaxial accelerations which will be used to compute the Head Injury Criterion (HIC) to assess vehicle performance.

THE COMPUTED HEAD INJURY CRITERION (HIC) FOR THE DUMMY SHALL NOT EXCEED 1000.

HEAD INJURY CRITERION – The HIC is computed from the resultant of the triaxial accelerations at the dummy head CG where the component accelerations are filtered to SAE CLASS 1000.

$$HIC = \left[\frac{1}{t_2 - t_1} \int_{t_1}^{t_2} a \, dt \right]^{2.5} (t_2 - t_1)$$

where $A_R = [A_x^2 + A_y^2 + A_z^2]^{1/2}$ Resultant Acceleration magnitude in g units at the dummy head CG, and

t_1 and t_2 are any two points in time during the impact event which are separated by not more than a 36 millisecond time.

NOTE: The SID/HIII will be also instrumented to measure triaxial forces and moments at the upper neck position and to measure chest and pelvis accelerations as outlined under section 8.2 for the purpose of collecting additional information about the event.

12. TEST DATA...Continued

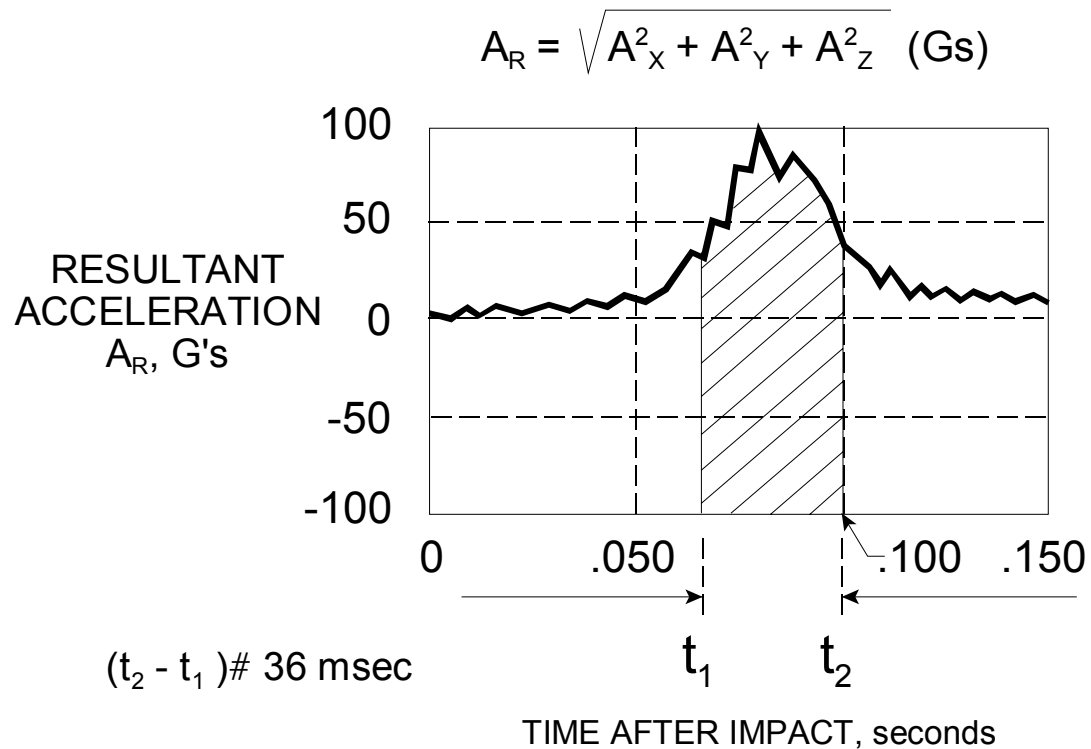

FIGURE 15

B. TEST VEHICLE ASSESSMENT - performance requirements are as follows;

(I) Vehicle Structural Integrity --

At the completion of each test the vehicle and film shall be examined to determine:

- (A) Whether the door(s) on the struck side of the test vehicle separated from the vehicle's main body at the hinges or latches.
- (B) Whether the door(s) on the far side (side opposite from the struck side) opened during the side impact crash event.
- (C) On hatchback models, whether the hatch opened during the side impact crash event.

12. TEST DATA....Continued

- (D) Whether interior trim components or dynamic system components remained attached during the impact event.
- (E) The intrusion levels into the occupant compartment.
- (F) Whether any fuel leakage occurred as a result of the impact.

All examination results shall be recorded in the final test report.

12.2 DATA PROCESSING

The acceleration data from the accelerometers mounted on the ribs, spine and pelvis of the test dummy are processed with the FIR 100 software. The upper neck force data are filtered to SAE channel filter class (CFC) 1000 and the upper neck moment data are filtered to SAE CFC 600. These filter classes are outlined in SAE J211 1/2 MAR95 recommended practice requirements.

12.3 COMPUTER DATA TAPE/DISK

The contractor shall deliver to NHTSA the final data tape or disk, digital printouts, and plots within five (5) working days after the crash test.

12.4 TEST DATA LOSS (RETEST)

A compliance test is not to be conducted unless all of the various test conditions specified in the applicable NHTSA Laboratory Test Procedure have been met. Failure of a contractor to obtain the required test data and to maintain acceptable limits on test parameters (such as impact velocity) in the manner outlined in the applicable NHTSA Laboratory Test Procedure may require a retest at the expense of the contractor. The retest costs will include the cost of the replacement vehicle (with the same equipment as the original vehicle) or item of motor vehicle equipment and all costs associated with conducting the retest. The original test vehicle used for the invalid test shall remain the property of NHTSA, and the retest vehicle shall remain the property of the contractor. If there is a test failure, the contractor shall retain the retest vehicle for a period not exceeding 180 days. If there is no test failure, the Contractor may dispose of the test vehicle upon notification from the COTR that the final test report has been accepted, after the stipulated minimum period specified as follows.

12. TEST DATA....Continued

NOTE: The tested vehicles, protected from the elements, shall be retained by the test contractor for a MINIMUM of 60 days so that NHTSA and vehicle manufacturer personnel can be given an inspection opportunity.

The Contracting Officer and the C.O.T.R. of NHTSA are the only officials authorized to notify the contractor that a retest is required. The retest shall be completed within two (2) weeks after receipt of notification by the appropriate NHTSA official that a retest is required. If a retest is conducted, no test report is required for the original test.

12.5 PARTIAL PAYMENT

The contractor shall exercise reasonable control to ensure that no data is lost or rendered useless. If some non-critical data (such as camera failure, film breakage) and/or critical data (such as dummy acceleration and speed control data) are not obtained for the crash test and the test is accepted by the Agency, PARTIAL PAYMENT MAY be made by deducting the costs for the missing or lost data on a per channel basis.

12.6 DATA RETENTION BY CONTRACTOR

The contractor shall retain at no extra cost to the agency, reproducible copies of all data tapes or disks (analog and digital), 16 mm movie films, and still photograph negatives.

12.7 DATA SHEETS

EXTERIOR PROFILE MEASUREMENTS

Prior to the test (with the test vehicle in the "as tested" configuration) exterior profile measurements of the impact side of the vehicle shall be made. These (pretest and post test) measurements are to be made at all five levels across the entire length of the vehicle at 150 mm intervals. These lateral measurements are made from a reference plane which is parallel to and 1000 mm from the test vehicle's longitudinal centerline. When making the post test measurements the measurements should be made from the reference plane to each individual target.

NOTE: The post test measurements shall begin at the first 150 mm mark forward of forwardmost point of the induced damage and end at the first (150 mm) mark past the rearwardmost point of the induced damage.

12. TEST DATA....Continued

Data sheets are provided as **tools** to document test data in the Final Test Report format outlined in the previous section. The contractor is not restricted from using other tools or expanding the data sheets provided in this section. Nevertheless, for consistency and uniformity in reporting data, the contractor must present the data in the **order** outlined in this TP.

12. TEST DATA....Continued

DATA SHEET 1
GENERAL TEST VEHICLE PARAMETER DATA

TEST VEHICLE INFORMATION:

MODEL YEAR/MAKE/MODEL: _____

BODY STYLE/COLOR: _____ VIN: _____

NHTSA NO.: _____; BUILD DATE: _____

ENGINE DATA: _____ cylinders; _____ CID; _____ Liter; _____ cc

PLACEMENT: ___ longitudinal ___ lateral

TRANSMISSION: _____ speeds; _____ manual; _____ automatic; _____ overdrive

FINAL DRIVE: _____ rear wheel drive; _____ front wheel drive; _____ four wheel drive

ODOMETER READING: _____ km.

OPTIONS: _____ A/C; _____ pwr. steering; _____ pwr. brakes; _____ pwr. windows

DATA RECORDED FROM VEHICLE'S TIRE PLACARD:

TIRE PRESSURE (AT CAPACITY): _____ psi Front; _____ psi Rear

RECOMMENDED TIRE SIZE: _____

TIRES ON VEHICLE: _____; Mfr.: _____

VEHICLE CAPACITY DATA:

Number of Occupants: _____ front; _____ rear _____ Total

Type of Front Seat(s): _____ buckets; _____ bench; _____ split bench

Type of Front Seat Back: _____ fixed; _____ adjustable with _____ lever or _____ knob

12. TEST DATA....Continued

Vehicle Maximum Capacity Loading = ____ kg. (A)

Number of Occupants X 68.04 kg. = ____ kg. (B)

Vehicle Cargo Capacity (A-B) = ____ kg.

TEST VEHICLE DELIVERED WEIGHT WITH MAXIMUM FLUIDS:

Right Front = ____ kg. Right Rear = ____ kg.

Left Front = ____ kg. Left Rear = ____ kg.

Total Front = ____ kg. Total Rear = ____ kg.

TOTAL WEIGHT = _____ kg.

Percent of Total Weight: Percent Front = _____ Percent Rear = _____

CALCULATION OF TEST VEHICLE TARGET WEIGHT:

Total Vehicle Delvd Weight/Max. Fluids = ____ kg. (A)

Max. Cargo Carrying Cap. of Vehicle = ____ kg. (B)

Weight of instrumented SID/HIII dummy = ____ kg. (C)

TEST VEHICLE TARGET WEIGHT (A + B + C) = ____ kg.

FULLY LOADED TEST VEHICLE (UDVW + SID/HIII + CARGO):

Right Front = ____ kg. Right Rear = ____ kg.

Left Front = ____ kg. Left Rear = ____ kg.

Total Front = ____ kg. Total Rear = ____ kg.

Percent Front = _____ Percent Rear = _____

TOTAL WEIGHT = _____ kg.

12. TEST DATA....Continued

AS TESTED WEIGHT. OF VEHICLE. (SID/HIII dummy + CARGO + EQUIPMENT & INSTRUMENTATION):

Right Front = _____ kg. Right Rear = _____ kg.

Left Front = _____ kg. Left Rear = _____ kg.

Total Front = _____ kg. Total Rear = _____ kg.

TOTAL WEIGHT = _____ kg.

Percent Front = _____ Percent Rear = _____

TEST VEHICLE ATTITUDE:

	AS DELIVERED	FULLY LOADED	READY FOR TEST
Right Front	_____ mm	_____ mm	_____ mm
Left Front	_____ mm	_____ mm	_____ mm
Right Rear	_____ mm	_____ mm	_____ mm
Left Rear	_____ mm	_____ mm	_____ mm
Right Door Sill Angle	_____	_____	_____
Left Door Sill Angle	_____	_____	_____
Front Bumper Angle	_____	_____	_____
Rear Bumper Angle	_____	_____	_____
Test Vehicle Wheelbase =	_____ mm		

C.G. = _____ mm rearward of front wheel centerline

12. TEST DATA....Continued

TOTAL VEHICLE LENGTH:

Right Side = _____ mm

Left Side = _____ mm

Centerline = _____ mm

FRONT SEAT CUSHION PLACEMENT:

Total Length of Adjustment Travel = _____ mm

Total Number of Adjustment Positions or Detents = _____

FRONT SEAT BACK ADJUSTMENT POSITION:

 Seat Back Torso Angle = _____ degrees

ADJUSTABLE STEERING COLUMN POSITION: _____

WINDOW POSITIONS:

Right Front = _____ Right Rear = _____

Left Front = _____ Left Rear = _____

AMOUNT OF STODDARD SOLVENT IN FUEL TANK:

Volume = _____ liters (92% to 94% of Useable Capacity)

LOCATION OF IMPACT POINT ON TEST VEHICLE SIDE TO BE IMPACTED:

Wheelbase = _____ mm

Impact Reference Line is _____ mm rearward of front axle centerline

RECORDED BY: _____ DATE: _____

APPROVED BY: _____

12. TEST DATA....Continued

DATA SHEET 2
TEST VEHICLE SUMMARY OF RESULTS

MODEL YEAR/MAKE/MODEL: _____

BODY STYLE: _____ VIN: _____

NHTSA NO.: _____ BUILD DATE: _____

TEST DATE: _____

Vehicle Overall Length = _____ mm

Vehicle Overall Width _____ mm

VEHICLE TEST WEIGHT (Pretest):

Left Front = _____ kg.

Left Rear = _____ kg.

Right Front = _____ kg.

Right Rear = _____ kg.

TOTAL Front = _____ kg.

TOTAL Rear = _____ kg.

TOTAL Vehicle Test Weight = _____ kg.

Wheelbase = _____ mm

Longitudinal C.G. from center of front axle = _____ mm

Impact Angle with respect to impactor = 90 degrees

IMPACT POINT:

Actual Impact Point = _____ mm [rearward or forward] of nominal impact ref. line
(LATERAL)

12. TEST DATA....Continued

MAXIMUM EXTERIOR STATIC CRUSH:

LEVEL 1 (___ mm above ground) = ___ mm

LEVEL 2 (___ mm above ground) = ___ mm

LEVEL 3 (___ mm above ground) = ___ mm

LEVEL 4 (___ mm above ground) = ___ mm

LEVEL 5 (___ mm above ground) = ___ mm

Maximum Post Test Intrusion = ___ mm

OCCUPANTS:

DRIVER DUMMY

Dummy ID: SID/HIII# _____

Restraint Used: _____

INSTRUMENTATION:

Number of Data Channels = _____

Number of Cameras:

Onboard = _____

Offboard = _____

Total Cameras = _____

REMARKS:

RECORDED BY: _____

DATE: _____

APPROVED BY: _____

12. TEST DATA....Continued

DATA SHEET 3
POST TEST OBSERVATIONS

TEST VEHICLE: _____ ; NHTSA NO.: _____

VISIBLE DUMMY CONTACT POINTS:

	SID/HIII
HEAD	
UPPER TORSO	
LOWER TORSO	
LEFT KNEE	
RIGHT KNEE	

DOOR OPENING:

	LEFT SIDE	RIGHT SIDE
FRONT		
REAR		

ARM REST LOCATION:

Front = _____

Rear = _____

SEAT MOVEMENT:

Front = _____

Rear = _____

12. TEST DATA....Continued

GLAZING DAMAGE:

Windshield: _____

Window: _____

PILLAR PERFORMANCE:

SILL SEPARATION:

OTHER NOTABLE IMPACT EFFECTS:

REMARKS:

RECORDED BY: _____ DATE: _____

APPROVED BY: _____

12. TEST DATA....Continued

DATA SHEET 4
SID/HIII INSTRUMENTATION DATA

TEST VEHICLE: _____ ; NHTSA NO.: _____

	SID/HIII ID#			
	POSITIVE		NEGATIVE	
	MAX (g)	TIME (msec)	MAX (g)	TIME (msec)
HEAD ACCELERATION				
X Direction				
Y Direction				
Z Direction				
NECK LOADS				
X Direction				
Y Direction				
Z Direction				
NECK MOMENTS				
X Direction				
Y Direction				
Z Direction				
RIB ACCELERATIONS				
Left Upper Rib (LUR) Y				
Left Lower Rib (LLR) Y				
SPINE ACCELERATIONS				
Lower Lateral Y				
PELVIS ACCELERATIONS				
Lateral Y				

(Continued on next page)

12. TEST DATA....Continued

REFERENCE:

Positive Direction:	Longitudinal (X) =	Rearward
	Lateral (Y) =	To Right
	Vertical (Z) =	Up
Negative Direction:	Longitudinal (X) =	Forward
	Lateral (Y) =	To Left
	Vertical (Z) =	Down

REMARKS:

RECORDED BY: _____ DATE: _____

APPROVED BY: _____

12. TEST DATA....Continued

DATA SHEET 5
VEHICLE PRETEST AND POST TEST MEASUREMENTS

TEST VEHICLE: _____ ; NHTSA NO.: _____

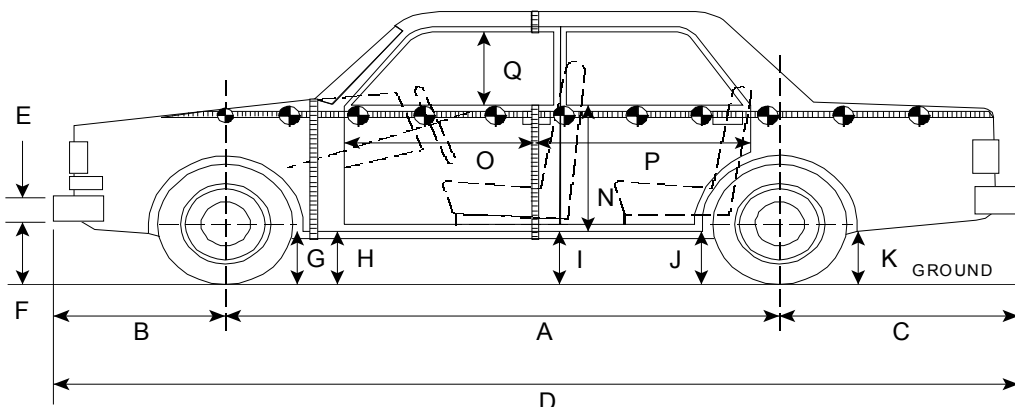

LEFT SIDE VIEW

All MEASUREMENTS IN MILLIMETERS (mm) WITH TOLERANCE OF ± 3 mm

	PRETEST	POST TEST	Δ CHANGE
A			
B			
C			
D			
E			

(Continued on next page)

12. TEST DATA....Continued

	PRETEST	POST TEST	CHANGE
*F			
*G			
*H			
*I			
*J1/J2			
*K			
L			
*M			
O			
P			
Q			

D = Length at Centerline
 E & L = Bumper thickness
 J1 = To Pinch Weld
 J2 = To Sill
 R = Right Side Length
 S = Left Side Length
 T = Width at B-Post

* THESE MEASUREMENTS ARE TO BE TAKEN IN THE "AS DELIVERED" AND IN THE "AS TESTED" CONFIGURATION (WHICH INCLUDES SID/HIII DUMMY, INSTRUMENTATION, CAMERAS, ETC.)

REMARKS:

RECORDED BY: _____ DATE: _____

APPROVED BY: _____

12. TEST DATA....Continued

DATA SHEET 6
SID/HIII LONGITUDINAL CLEARANCE DIMENSIONS

TEST VEHICLE: _____ ; NHTSA NO.: _____

SID/HIII DUMMY LONGITUDINAL MEASUREMENTS

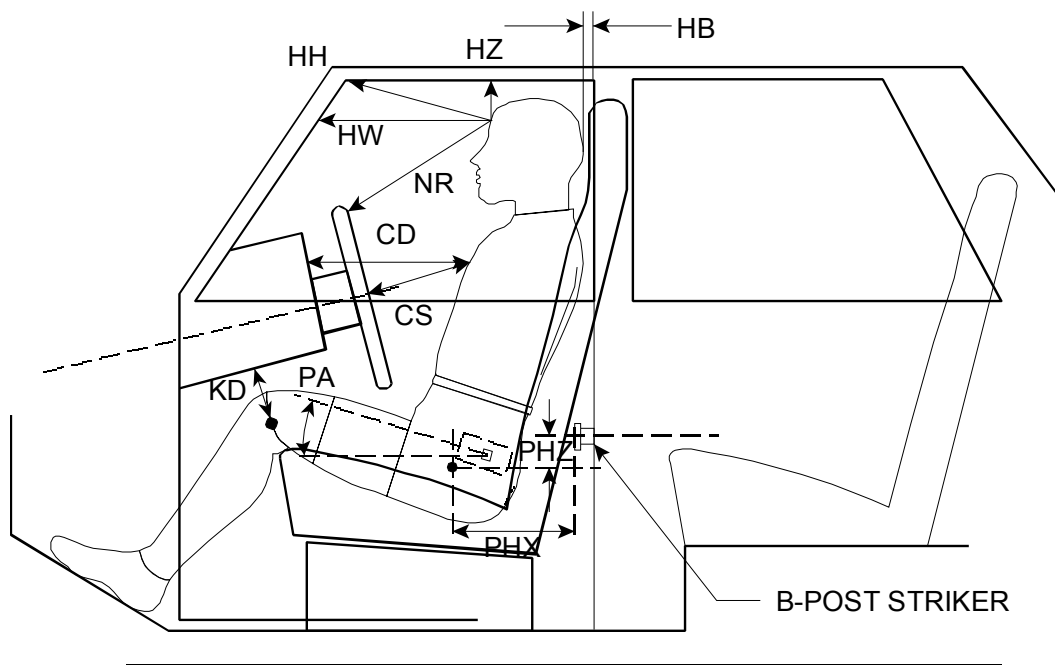

LEFT SIDE VIEW

MEASUREMENT (mm)	SID/HIII ID# _____
HB	
HH	
HW	
HZ	
NR	
CD	
CS	

(Continued on next page)

12. TEST DATA....Continued

MEASUREMENT (mm)	SID/HIII ID# _____
KDL(KDA ^o)/KBL(KDA ^o)	/ (°)
KDR(KBA ^o)/KBR(KBA ^o)	/ (°)
PA ^o	
PHX	
PHY	
PHZ	

REMARKS:

RECORDED BY: _____ DATE: _____

APPROVED BY: _____

12. TEST DATA....Continued

DATA SHEET 7
SID/HIII DUMMY LATERAL CLEARANCE DIMENSIONS

TEST VEHICLE: _____ ; NHTSA NO.: _____

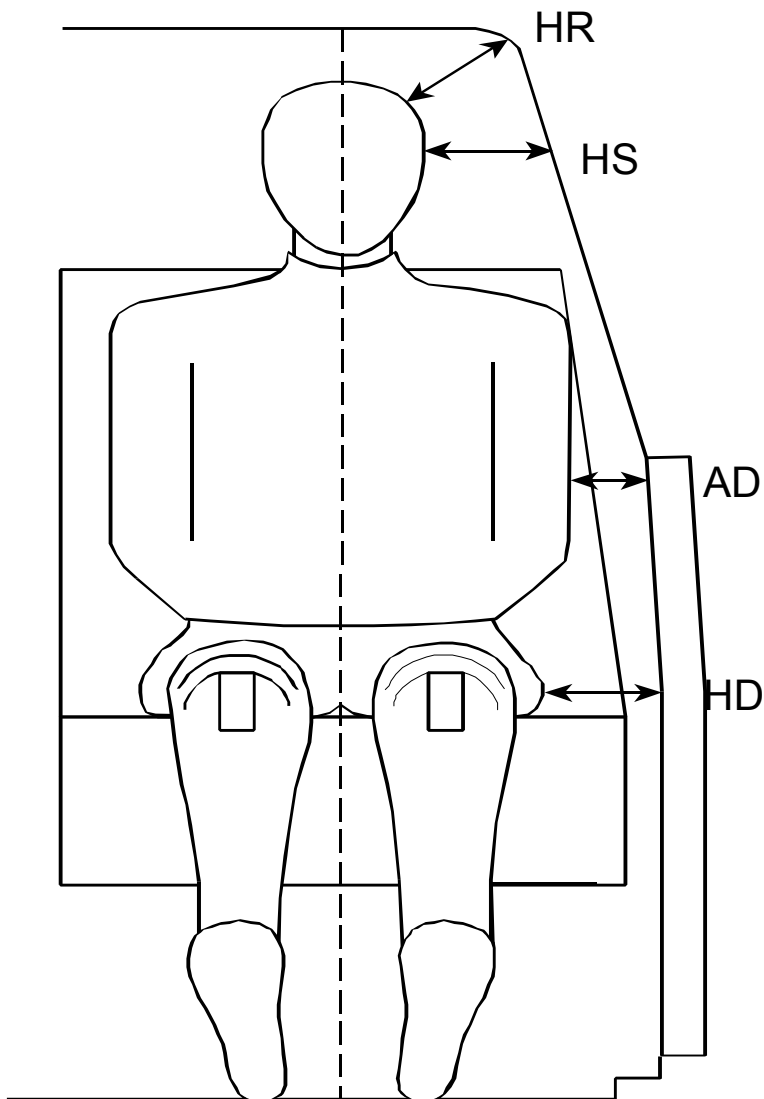

MEASUREMENT(mm)	SID/HIII ID# _____
HR	
HS	
AD	
HD	

12. TEST DATA....Continued

DATA SHEET 8
VEHICLE SIDE MEASUREMENTS

TEST VEHICLE: _____ ; NHTSA NO.: _____

PRETEST AND POST TEST EXTERIOR PROFILE MEASUREMENTS

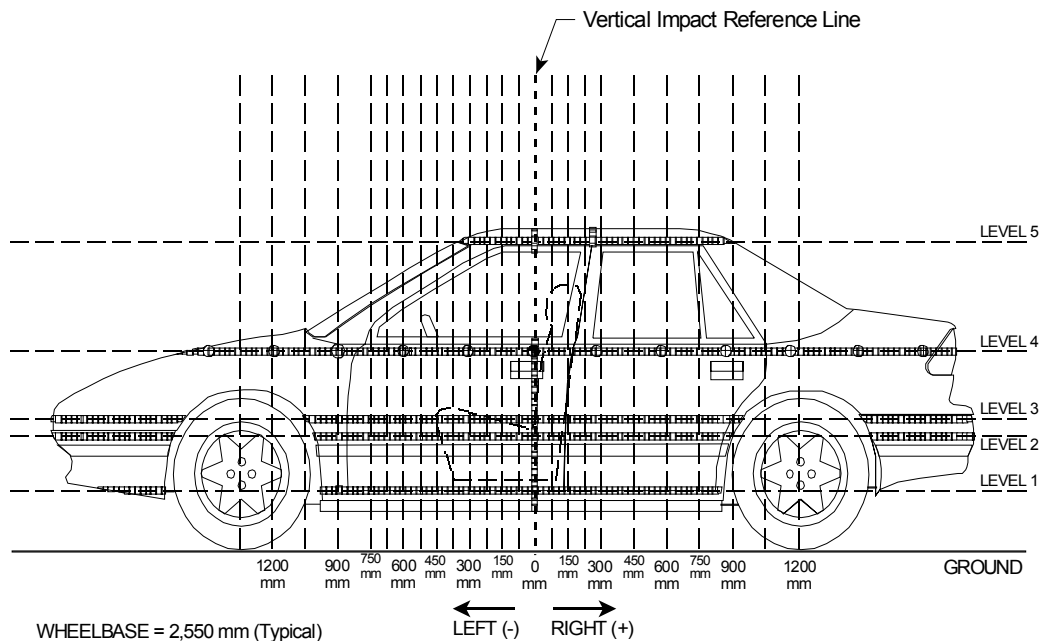

LEFT SIDE VIEW

MEASUREMENTS ALONG THE VERTICAL 0 mm. LINE SHOWN ABOVE:

LEVEL 5 @ Window Top = _____ mm

LEVEL 4 @ Window Sill = _____ mm

LEVEL 3 @ Mid Door = _____ mm

LEVEL 2 @ Occupant H-Point = _____ mm

LEVEL 1 @ Sill Top Height = _____ mm

12. TEST DATA....Continued

DATA SHEET 9
VEHICLE EXTERIOR CRUSH PROFILES – ALL LEVELS

NOTE: Due to limited space the following table only indicates measurements from -75 mm to 225 mm, however, tape should be applied along the entire length of target vehicle and measurements made every 75 mm, across span of induced damage (see graphic on next page). When making post test measurements be sure to measure to same point measured originally. **Measurements should be accurate to ± 3 mm.**

LOCATION	WEIGHT		DISTANCE IN MILLIMETERS (mm) FROM IMPACT POINT (Measurements Continued On Next Page)				
			-75	0	75	150	225
LEVEL 1		PRE					
SIDE		POST					
SILL		CRUSH					
LEVEL 2		PRE					
H-		POST					
POINT		CRUSH					
LEVEL 3		PRE					
MID-		POST					
DOOR		CRUSH					
LEVEL 4		PRE					
WINDOW		POST					
SILL		CRUSH					
LEVEL 5		PRE					
WINDOW		POST					
TOP		CRUSH					

REMARKS

12. TEST DATA. . .Continued

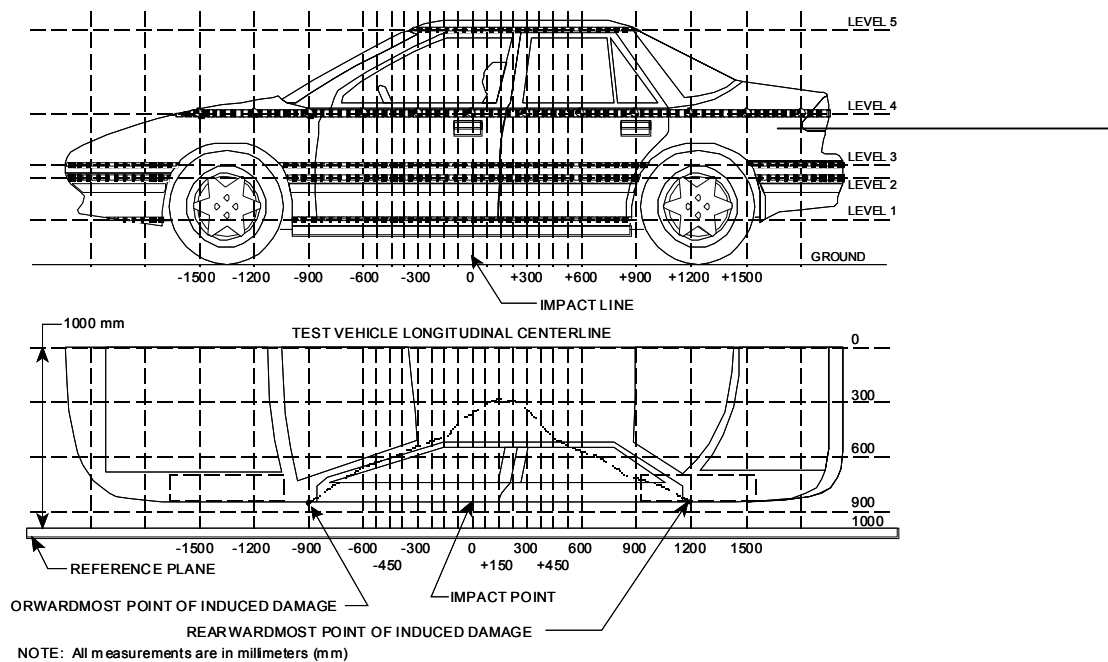

12. TEST DATA....Continued

DATA SHEET 10
VEHICLE DAMAGE PROFILE DISTANCES

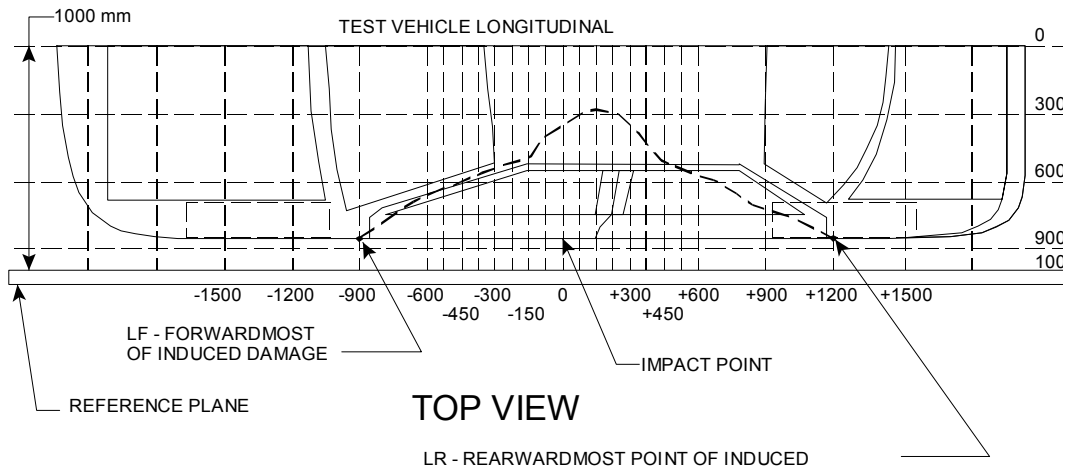

MEASUREMENT CONVENTIONS:

Forward of the impact point (towards front of vehicle) is considered negative (-).
Rearward of the impact point (toward rearend of vehicle) is considered positive (+).

NOTE: All measurements are in millimeters (mm) and should be accurate to ± 3mm .

DPD MEASUREMENTS	POST TEST (mm)	PRETEST (mm)	STATIC CRUSH (mm)
1 (LR = ___ mm)			0.0
2			
3			
4			
5			
6 (LF = ___ mm)			0.0

REMARKS:

RECORDED BY: _____

DATE: _____

APPROVED BY: _____

12. TEST DATA....Continued

DATA SHEET 11
HIGH SPEED CAMERA LOCATIONS AND DATA

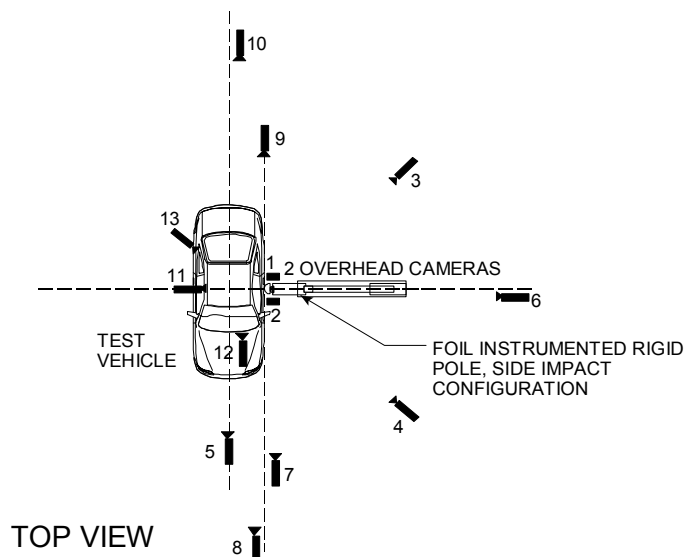

REFERENCE (from Point of Impact): + X = Rearward, + Y = To Right, + Z = Up

* All measurements accurate to ± 6 mm.

CAMERA No.	VIEW	COORDINATES (mm)			ANGLE	LENS (mm)	MINIMUM FILM SPEED (fps)
		X*	Y*	Z*			
1	Overhead view of test vehicle						1000
2	Overhead closeup view of impact plane						1000
3	Left side 45° – rearward pole view						1000
4	Left side 45° – forward pole view						1000
5	Real time (24 fps) film coverage of test						1000
6	Left side – rear pole view						1000
7	Front ground level – vehicle/pole impact						1000
8	Front ground level – vehicle roof targets and vehicle/pole impact						1000
9	Rear ground level – vehicle/pole impact						1000
10	Rear ground level						24
11	Test vehicle onboard driver -- side view						1000
12	Test vehicle onboard driver – front view						1000
13	Test vehicle o/b driver – 3/4 rear view						1000

12. TEST DATA....Continued

Data Sheet 12 DUMMY DAMAGE CHECKLIST – SID/HIII

Dummy Serial No. _____

Date: _____

OK Damaged (Begin with general cleaning)

Outer skin on entire dummy (gashes, rips, etc.)

Head - Check that ballast is secure

Gashes, rips, general appearances, etc.

Neck - Broken or cracks in rubber

Check that upper neck bracket is firmly attached to lower neck

Check for looseness at the condyle joint

Nodding blocks – cracked or out of position

Spine - Broken or cracks in rubber

Ribs - Check all ribs and rib supports for damage (bent or broken)

Check damping material or separation or cracks

Three rubber bumpers in place

Lateral Shock Absorber - Bent or broken

Transducer Leads - Torn cables

Accelerometer Mountings -(head, ribs, spine, and pelvis) – Check
for secure mounting).

Knees- Check outer skin, insert and casting (without removing
insert)

Limbs- Check for normal movement and adjustment

Head / Neck bracket attachment - Check to see if cracked or
broken

13. FORMS

Forms, like Data Sheets, are provided as **tools** to use in the exchange of data between the COTR and the contractor. Forms, unlike Data Sheets, are not **part** of the Final Test Report. The contractor is not restricted from using other tools or expanding the forms outlined in this section.

FORM 1 – VEHICLE CONDITION REPORT

A "Vehicle Condition Report" form (example shown on next page) must be submitted to the COTR with the copies of the Final Test Report. The first page of the form shall be completed when the test vehicle arrives at the testing laboratory. The second page of the form is completed after the test. The forms shall be **legible** (hand written forms are unacceptable) and **complete** (all information requested is filled out).

FORM 2 – TEST VEHICLE INFORMATION

A "Test Vehicle Information" form (such as the example shown on the following pages) will be supplied by the COTR to the contractor before testing preparation. Information on this form is supplied by the automobile manufacturer to aid in the initial test set-up and shall be considered as **reference material**. After vehicle preparation is complete, the Test Vehicle Information form shall be discarded.

13. FORMS....Continued

FORM 1
REPORT OF VEHICLE CONDITION

CONTRACT NO.: DTNH22-_____ ; DATE: _____

FROM: _____

TO: _____

The vehicle was inspected upon arrival at the laboratory for the test and found to contain all the equipment listed below. All variances have been reported within 2 working days of the vehicle arrival, by letter, to the NHTSA Industrial Property Manager (NAD-30), with a copy to the COTR. The vehicle is again inspected, after the above test has been conducted, and all changes are noted below. The final condition of the vehicle is also noted in detail.

TEST VEHICLE MODEL YEAR/MAKE/MODEL/BODY STYLE:

NHTSA NO.: _____; BODY COLOR: _____; VIN: _____

ODOMETER READINGS:

ARRIVAL = _____ miles DATE: _____

COMPLETION = _____ miles DATE: _____

PURCHASE PRICE= \$ _____

DEALER'S NAME: _____

ENGINE DATA: _____ Cylinders _____ Liters _____ Cubic inches

TRANSM. DATA: _____ Automatic _____ Manual _____ No. of speeds

DRIVE DATA: _____ Rear Drive _____ Front Drive _____ 4 Wheel Drive

13. FORMS....Continued

TIRE DATA:

Size: _____

Mfr.: _____

CHECK APPROPRIATE BOXES FOR VEHICLE EQUIPMENT:

<input type="checkbox"/>	Air Conditioning	<input type="checkbox"/>	Traction Control	<input type="checkbox"/>	Clock
<input type="checkbox"/>	Tinted Glass	<input type="checkbox"/>	All Wheel Drive	<input type="checkbox"/>	Roof Rack
<input type="checkbox"/>	Power Steering	<input type="checkbox"/>	Cruise/speed Control	<input type="checkbox"/>	Console
<input type="checkbox"/>	Power Windows	<input type="checkbox"/>	Rear Wdo Defroster	<input type="checkbox"/>	Driver Air-bag
<input type="checkbox"/>	Power Door Locks	<input type="checkbox"/>	Sun Roof or T-Top	<input type="checkbox"/>	Passenger Air-bag
<input type="checkbox"/>	Power Seat(s)	<input type="checkbox"/>	Tachometer	<input type="checkbox"/>	Front Disc Brakes
<input type="checkbox"/>	Power brakes	<input type="checkbox"/>	Tilt Steering Wheel	<input type="checkbox"/>	Rear Disc Brakes
<input type="checkbox"/>	Anti-lock brake sys.	<input type="checkbox"/>	AM/FM Cassette Radio	<input type="checkbox"/>	Other

LIST OTHER PERTINENT OPTIONAL EQUIPMENT:

EQUIPMENT THAT IS NO LONGER ON THE TEST VEHICLE AS PREVIOUSLY NOTED:

EXPLANATION FOR EQUIPMENT REMOVAL:

TEST VEHICLE CONDITION:

RECORDED BY: _____ DATE: _____

APPROVED BY: _____

13. FORMS....Continued

FORM 2
TEST VEHICLE INFORMATION

Veh MY/Make: _____

Model/Body Style: _____

1. NOMINAL DESIGN RIDING POSITION –
For adjustable driver and passenger seat backs.
Please describe how to position the
inclinometer to measure the seat back angle.
Include description of the location of the
adjustment latch detent if applicable. Indicate,
if applicable, how the detents are numbered
(Is the first detent "0" or "1"?).
Seat back angle for driver's seat = ____°
Measurement Instructions:

Seat back angle for front passenger's seat = ____°
Measurement Instructions:

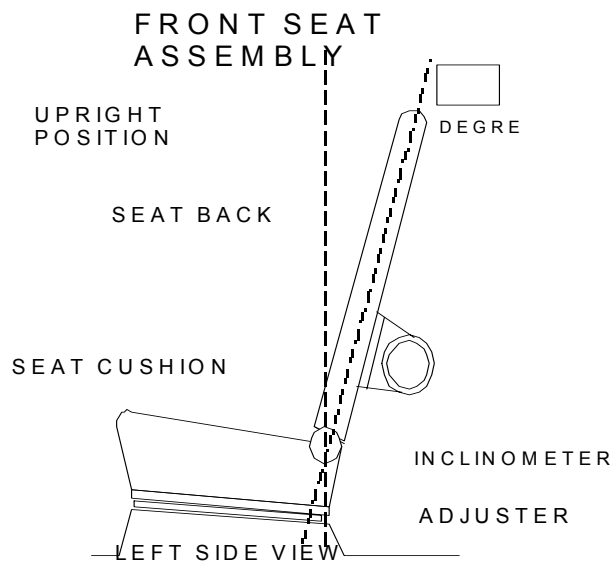

2. SEAT FORE & AFT POSITIONS --
Provide instructions for positioning the driver and
front outboard passenger seat(s) in the center of fore and aft travel.
For example, provide information to locate
the detent in which the seat track is to be
locked.
Positioning of the driver's seat:

Positioning of the passenger's seat (if
applicable):

VEHICLE FUEL TANK ASSEMBLY

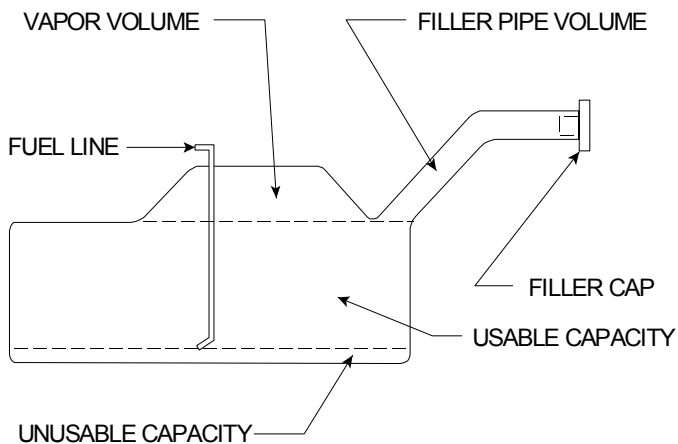

3. FUEL TANK CAPACITY DATA –

- 3.1 A. "Usable Capacity" of standard
equipment fuel tank =
_____ gallons (Liters).
- B. "Usable Capacity" of optional
equipment fuel tank =
_____ gallons (Liters).
- C. "Usable Capacity" of vehicle(s) used
for certification testing to requirements
of FMVSS 301 = _____ gallons (Liters).

13. FORMS....Continued

Operational Instructions:

3.2 Amount of Stoddard solvent added to vehicle(s) used for certification test(s) = _____ gallons

3.3 Is vehicle equipped with electric fuel pump?

Yes – ____ No – ____

If YES, explain the vehicle operating conditions under which the fuel pump will pump fuel.

4. STEERING COLUMN ADJUSTMENTS –

Steering wheel and column adjustments are made so that the steering wheel hub is at the geometric center of the locus it describes when it is moved through its full range of driving positions.

If the tested vehicle has any of these adjustments, does your company use any specific procedures to determine the geometric center.

Operational Instructions:

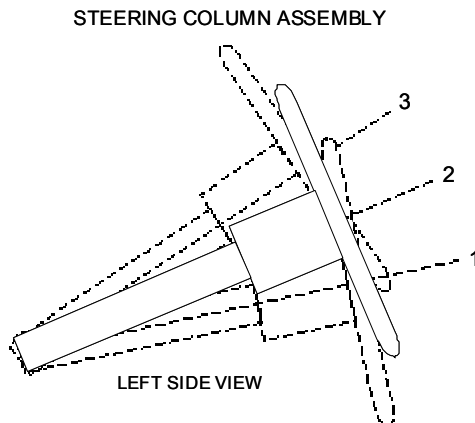

APPENDIX A
LABORATORY CONFIGURATION AND PERFORMANCE VERIFICATION
PROCEDURE FOR SIDE IMPACT HYBRID DUMMY (SID/HIII)
PART 572, SUBPART M (SID/HIII)

TABLE OF CONTENTS

		PAGE
1.	INTRODUCTION	A2
2.	PURPOSE	A2
3.	APPLICATION	A2
4.	GOOD HOUSEKEEPING	A2
5.	SECURITY	A3
6.	TEST SCHEDULING	A4
7.	CONTRACTOR'S IN-HOUSE TEST PROCEDURE	A4
8.	TEST DATA DISPOSITION	A4
9.	REQUIREMENT NONCONFORMANCE	A4
10.	CALIBRATION OF TEST INSTRUMENTATION	A4
11.	INSTRUMENTATION LIST	A5
12.	STILL PHOTOGRAPHS	A5
13.	GENERAL DESCRIPTION OF SID/HIII	A6
14.	GENERAL TEST CONDITIONS	A6
15.	UPRIGHT SEATED POSITION FOR SID/HIII	A7
16.	SID/HIII CONFIGURATION VERIFICATION TESTING	A9
17.	SID/HIII ACCELEROMETER REQUIREMENTS	A14
18.	SID PERFORMANCE VERIFICATION TESTING	
	A. HEAD DROP TEST (LATERAL)	A15
	B. NECK PENDULUM TEST	A18
	C. THORAX	A24
	D. LUMBAR SPINE AND PELVIS	A27
	E. INSTRUMENTATION AND TEST CONDITIONS	A32
19.	BENCH TEST FOR CHEST CAVITY SHOCK ABSORBER	A34
20.	VERIFICATION TEST DATA SUMMARY	A39
21.	CHEST CAVITY SHOCK ABSORBER	
	BENCH TEST VERIFICATION DATA	A39

1. INTRODUCTION

The Side Impact Hybrid Dummy (SID/HIII) shall be used as a tool to determine occupant injury levels experienced during rigid pole side impact protection compliance tests. The SID/HIII is based on the Part 572F test dummy used in FMVSS 214, with the following exceptions. The head and neck have been replaced with the Part 572E head and neck assemblies and a modified head-neck bracket assembly.

2. PURPOSE

The purpose of this SID/HIII Configuration and Performance Verification Test Procedure is to provide contractors with standard test procedures for conducting vehicle side impact test usage verification tests so that repetitive and correlative test results can be obtained. The following performance tests have been developed to establish a uniform procedure for all SID/HIII users:

- A. Head lateral impact test
- B. Neck lateral impact test
- C. Thorax lateral impact test
- D. Lumbar Spine and Pelvis lateral impact test

In addition, a dummy configuration and chest cavity shock absorber performance test will be conducted for each dummy. See SID/HIII on next page in Figure 1.

3. APPLICATION

The performance verification test procedure for the SID/HIII is intended for use by independent testing laboratories under contract to the NHTSA's Office of Vehicle Safety Compliance (OVSC). The procedure must be used by all OVSC contract laboratories conducting vehicle rigid pole side impact protection tests per the requirements of FMVSS 201.

4. GOOD HOUSEKEEPING

NHTSA contract laboratories conducting SID/HIII configuration and performance verification tests must maintain the entire laboratory area, test fixtures, and instrumentation in orderly and clean condition. Instrumentation used for testing must be displayed in a professional manner and present a good appearance.

5. SECURITY

All NHTSA SID/HIII dummies delivered to the contract laboratory as Government Furnished Property (GFP) must be stored in a safe and secure area such as the dummy configuration and performance verification room. The contractor is responsible for the security of the GFP dummies.

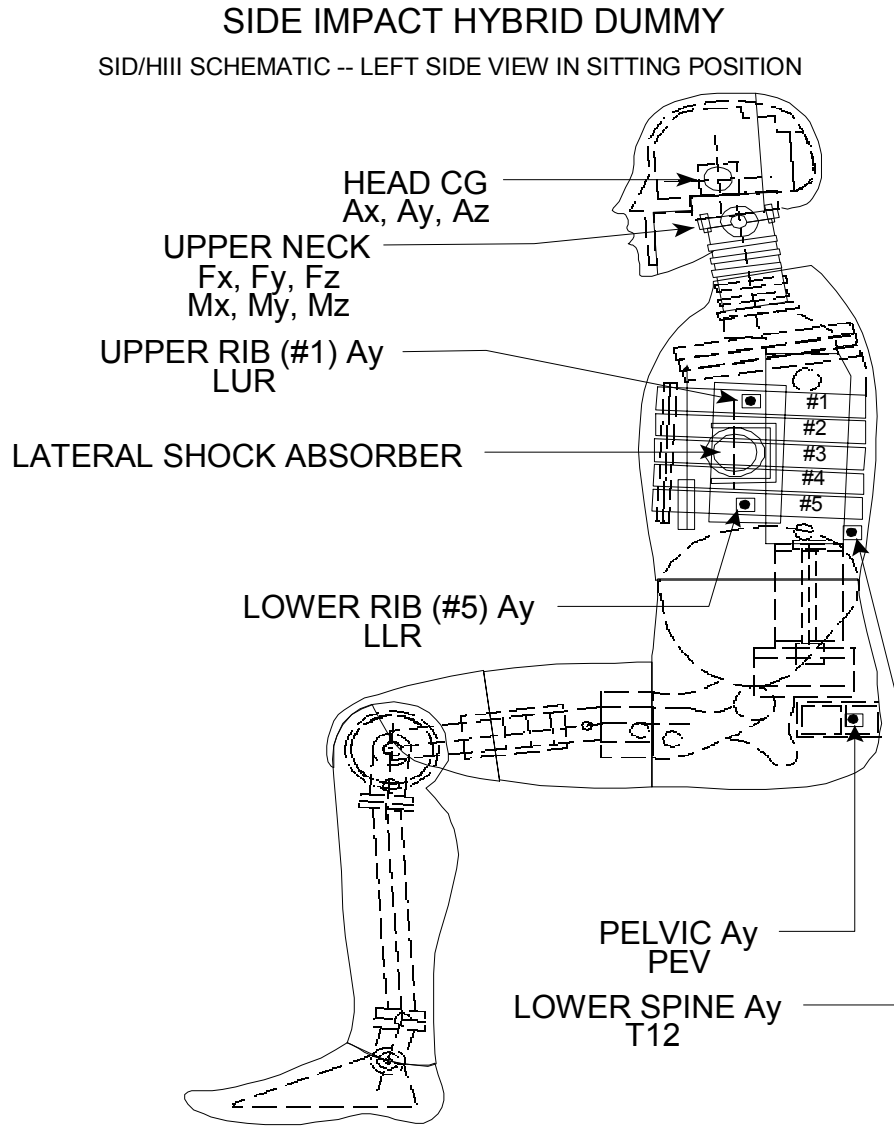

FIGURE 1

6. TEST SCHEDULING

The SID/HIII dummies are being subjected to verification testing in order to be utilized in side impact protection compliance tests to measure levels of occupant protection. The schedule for verification tests must be correlated with that of the rigid pole side impact protection test program.

7. CONTRACTOR'S IN-HOUSE TEST PROCEDURE

Prior to conducting any SID/HIII configuration and performance verification tests, the contract laboratory must submit a copy of their detailed in-house procedure to the COTR for approval. The contractor's procedure shall include a complete list of test equipment to be used along with a glossy 8in by 10 in black and white or color photograph of each piece of test equipment in the verification laboratory. Instrumentation accuracy, dates of calibration, check-off sheets, and individual worksheets shall be included in the contractor's procedure.

8. TEST DATA DISPOSITION

All verification test data for each SID/HIII shall be maintained in sequence by date during the side impact protection test program and the verification data shall be included in each final report for the SID/HIIIs used for that particular rigid pole side impact protection test.

9. REQUIREMENT NONCONFORMANCE

Any indication of SID/HIII nonconformance to the calibration performance requirements shall be communicated to the COTR in order that replacement components can be ordered from the dummy manufacturer(s). It is mandatory that the contractor maintain an adequate inventory of SID/HIII components which must be replaced frequently such as molded necks, lumbar spines, head skins, rib wraps, etc. The COTR will work with the contractor's verification laboratory engineer/technician to insure that a dummy replacement component shortage does not jeopardize the rigid pole side impact protection compliance test schedule.

10. CALIBRATION OF TEST INSTRUMENTATION

The calibration requirements that are listed in the current Laboratory Procedure No. TP-201P shall apply to verification laboratory instrumentation.

11. INSTRUMENTATION LIST

The following contractor instrument calibration information shall be submitted to the COTR prior to the initiation of the dynamic side impact test program. This should include contractor SID/HIII accelerometers along with laboratory instruments.

- A. Manufacturer's name
- B. Instrument Model Number
- C. Instrument Serial Number
- D. Date of last calibration
- E. Date of next calibration

12. STILL PHOTOGRAPHS

Two sets of the following 8 in. by 10 in. glossy black and white (color is optional) photographs shall be submitted to the COTR with the contractor's in-house verification test procedure prior to initiation of the rigid pole side impact protection compliance test program at the laboratory.

- A. Head Drop Test Setup (Lateral)
- B. Neck Pendulum Test Setup (Lateral)
- C. Thorax Impact Test setup
- D. Lumbar Spine and Pelvis Impact Test setup
- E. Chest Shock Absorber Test setup
- F. SID/HIII in "upright seated position" with the following views:
 - (1) Front View
 - (2) Left Side View
 - (3) Right Side View
 - (4) Rear View

12. STILL PHOTOGRAPHS....Continued

- E. Top view of SID/HIII chest cavity with outer skin removed
- F. Overall view of instrumentation used for dummy configuration and performance verification tests.

13. GENERAL DESCRIPTION OF SID/HIII

- A. The SID/HIII consists of component parts and component assemblies which are described in the drawings and specifications of the Part 572F and Part 572E in addition to a new head-neck bracket, and modified upper and middle shoulder foam pieces.
- B. The structural properties of the SID/HIII are such that the dummy conforms to the requirements of this subpart in every respect both BEFORE and AFTER being used in side impact protection compliance tests.
- C. Disassembly, inspection, and assembly procedures; external dimensions and weight; and a dummy drawing list are set forth in the SID/HIII User's Manuals.

14. GENERAL TEST CONDITIONS

- A. Performance pretests of the assembled SID/HIII are separated in time by a period of not less than 20 minutes unless otherwise specified.
- B. Surfaces of the SID/HIII components are not painted.
- C. Limb joints of the SID/HIII are set at the force between 1 and 2 g's, which just supports the limbs' weight when the limbs are extended horizontally forward. The force required to move a limb segment does not exceed 2 g's throughout the range of limb motion.
- D. SID/HIII performance tests are conducted at any temperature from 18.9EC (66EF) to 25.6EC (78EF), unless indicated otherwise, and at any relative humidity from 10 percent to 70 percent after exposure of the dummy to these conditions for a period of not less than 4 hours.

15. UPRIGHT SEATED POSITION FOR SID/HIII

For the performance of the thorax and lumbar spine/pelvis tests, the SID/HIII is positioned as follows:

- A. The dummy is placed on a flat, rigid, clean, dry, horizontal smooth aluminum surface (see figure on next page) whose length and width dimensions are not less than 407 mm (16 inches), so that the SID/HIII midsagittal plane is vertical and centered on the test surface. The SID/HIII torso is positioned to meet the requirements of the thorax and lumbar spine/pelvis test. The seating surface is without the back support and the SID/HIII is positioned so that its midsagittal plane is vertical and centered on the seat surface.
- B. The legs are positioned so that their centerlines are in planes parallel to the midsagittal plane.
- C. The SID/HIII's pelvis is adjusted so that the upper surface of the lumbar-pelvic adaptor is horizontal.
- D. The upper legs are positioned symmetrically about the midsagittal plane so that the distance between the knee pivot bolt heads is $290 \text{ mm} \pm 2.5 \text{ mm}$ ($11.5 \text{ in} \pm 0.1 \text{ in}$).
- E. Orient both the left and right femurs by positioning the centerline of the $\frac{1}{2}$ -13 shoulder bolt attaching the upper leg bone to the femur assembly horizontal and perpendicular to the midsagittal plane within one degree.
- F. The lower legs are positioned straight forward and in planes parallel to the midsagittal plane so that the lines between the midpoint of the knee pivots and the ankle pivots are horizontal.

15. UPRIGHT SEATED POSITION FOR SID/HIII....Continued

UPRIGHT SEATED POSITION FOR SID/HIII

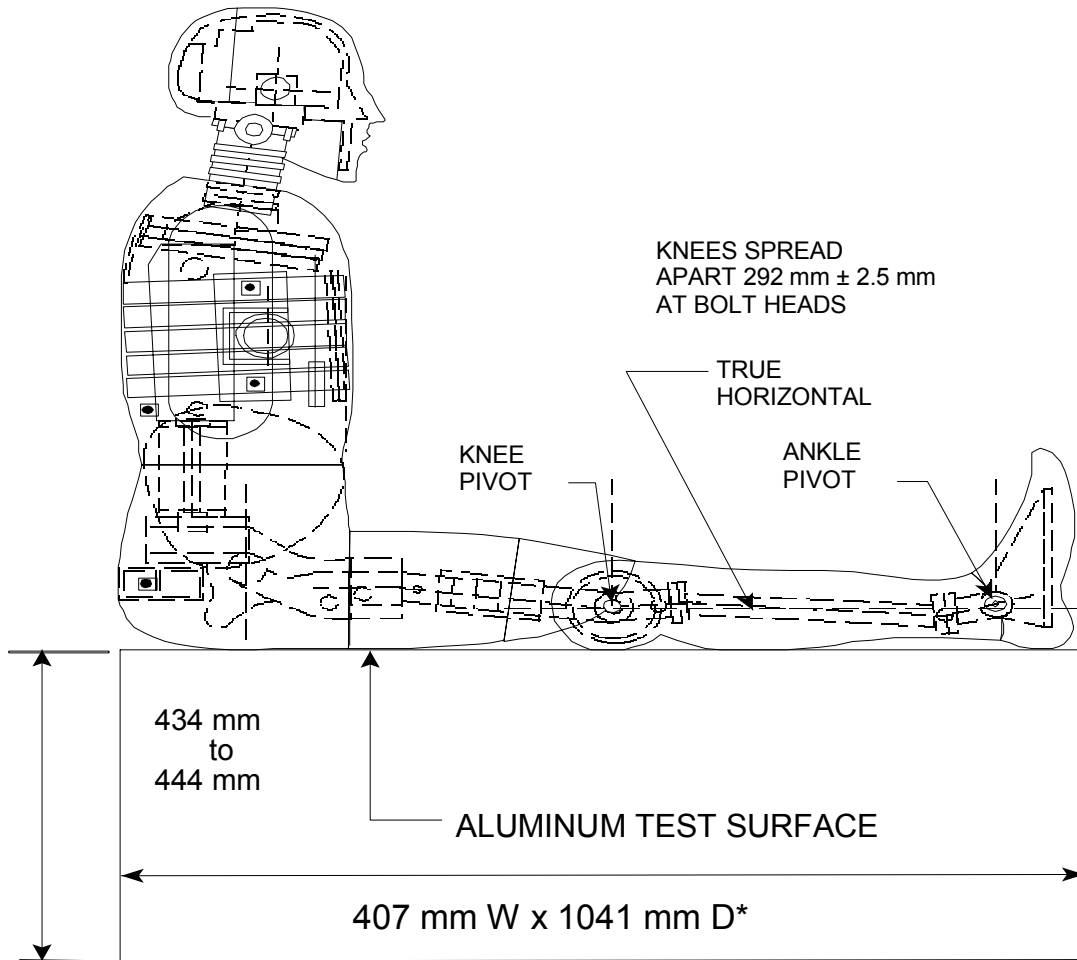

* This dimension must be at least 407 mm

FIGURE 2

16. SID/HIII CONFIGURATION VERIFICATION TESTING

- A. Place the SID/HIII in the **Upright Seated Position** except that the legs are positioned in the vertical plane as shown in Figure 3.
- B. Adjust and secure the head so that its occiput is 43 mm (1.7 in) forward of the transverse vertical plane with the vertical mating surface of the skull with its cover parallel to the transverse vertical plane.
- C. Adjust and secure the thorax so that the rear surface of the upper thoracic spine accelerometer (T_1) mounting surface is inclined 3 degrees forward of the vertical.
- D. Measure the seated height from the seating surface to the uppermost point on the head-skin surface.
- E. Measure the H-Point locations from the seating surface to the center of the holes in the pelvis flesh covering in line with the hip motion ball.
- F. Measure the knee pivot distance from the backline to the center of the knee pivot bolt head.
- G. Measure the knee pivot distance from the floor surface from the center of the knee pivot bolt head to the bottom of the heel when the SID/HIII foot is horizontal and pointing forward.
- H. Measure the hip width at the widest point of the pelvic section.

All configuration data shall be presented on the data sheet which follows.

16. SID/HIII CONFIGURATION VERIFICATION TESTING....Continued

SID/HIII CONFIGURATION SETUP

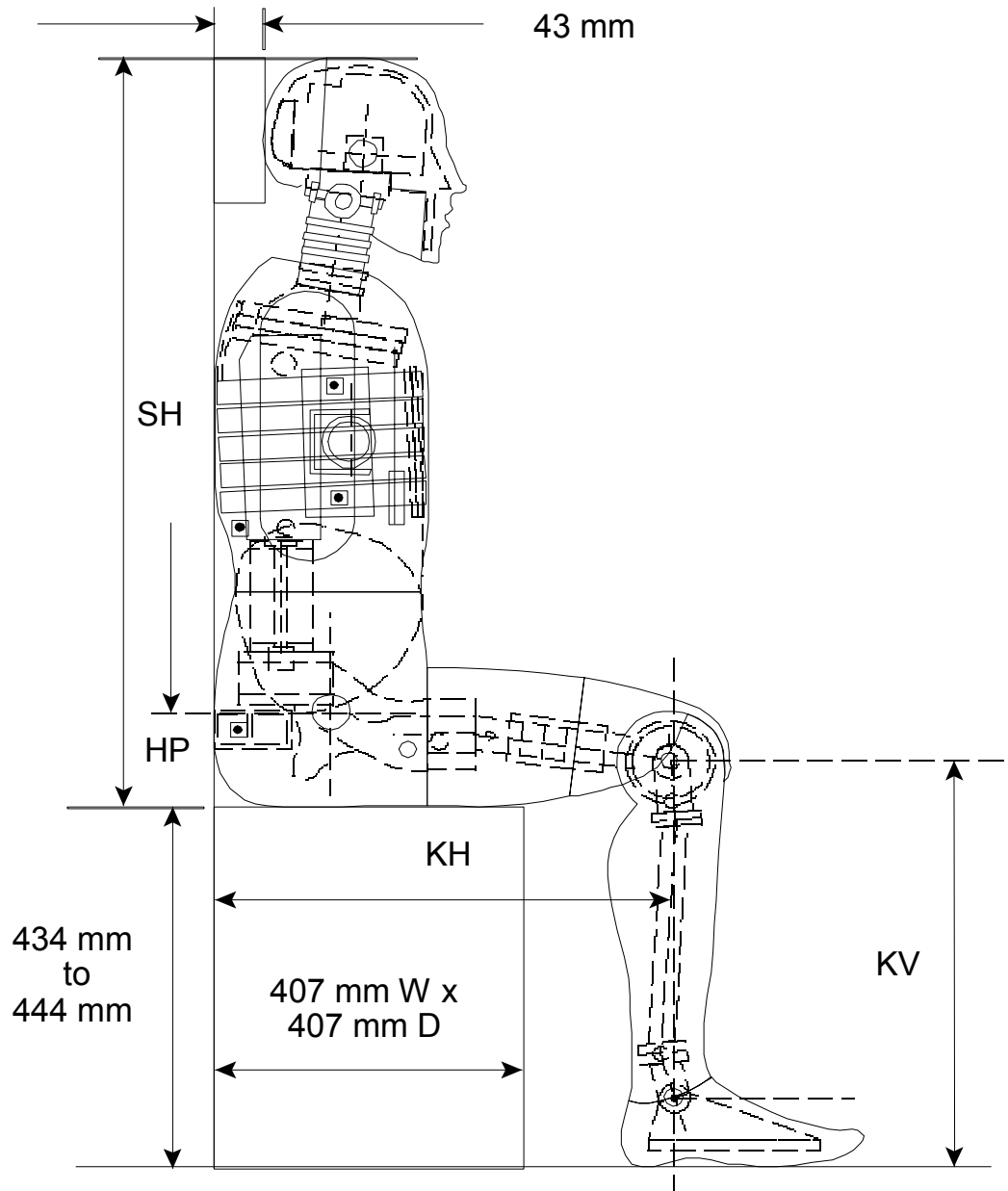

FIGURE 3

16. SID/HIII CONFIGURATION VERIFICATION TESTING....Continued

SID/HIII WITH CHEST FLESH INSTALLED

NHTSA DUMMY I.D. NUMBER: _____

DATE OF CONFIGURATION VERIFICATION: _____

SEQUENTIAL VERIFICATION NUMBER FOR DUMMY: _____
 (Sequential number beginning with "1" at the start of each fiscal year's crash test program)

TECHNICIAN: _____

		PART 572M SPECIFICATION	PRETEST	POST TEST
SH	SEATED HEIGHT	889 mm - 909 mm 35.0 in - 35.8 in		
HP	HIP PIVOT HEIGHT	99 mm 3.9 in Ref.		
KH	KNEE PIVOT FROM BACK LINE	511 mm - 526 mm 20.1 in to 20.7 in		
KV	KNEE PIVOT FROM FLOOR	490 mm - 505 mm 19.3 in to 19.9 in		
HW	HIP WIDTH	356 mm - 391 mm 14.0 in to 15.4 in		

16. SID/HIII CONFIGURATION VERIFICATION TESTING....Continued

SID/HIII CONFIGURATION SETUP

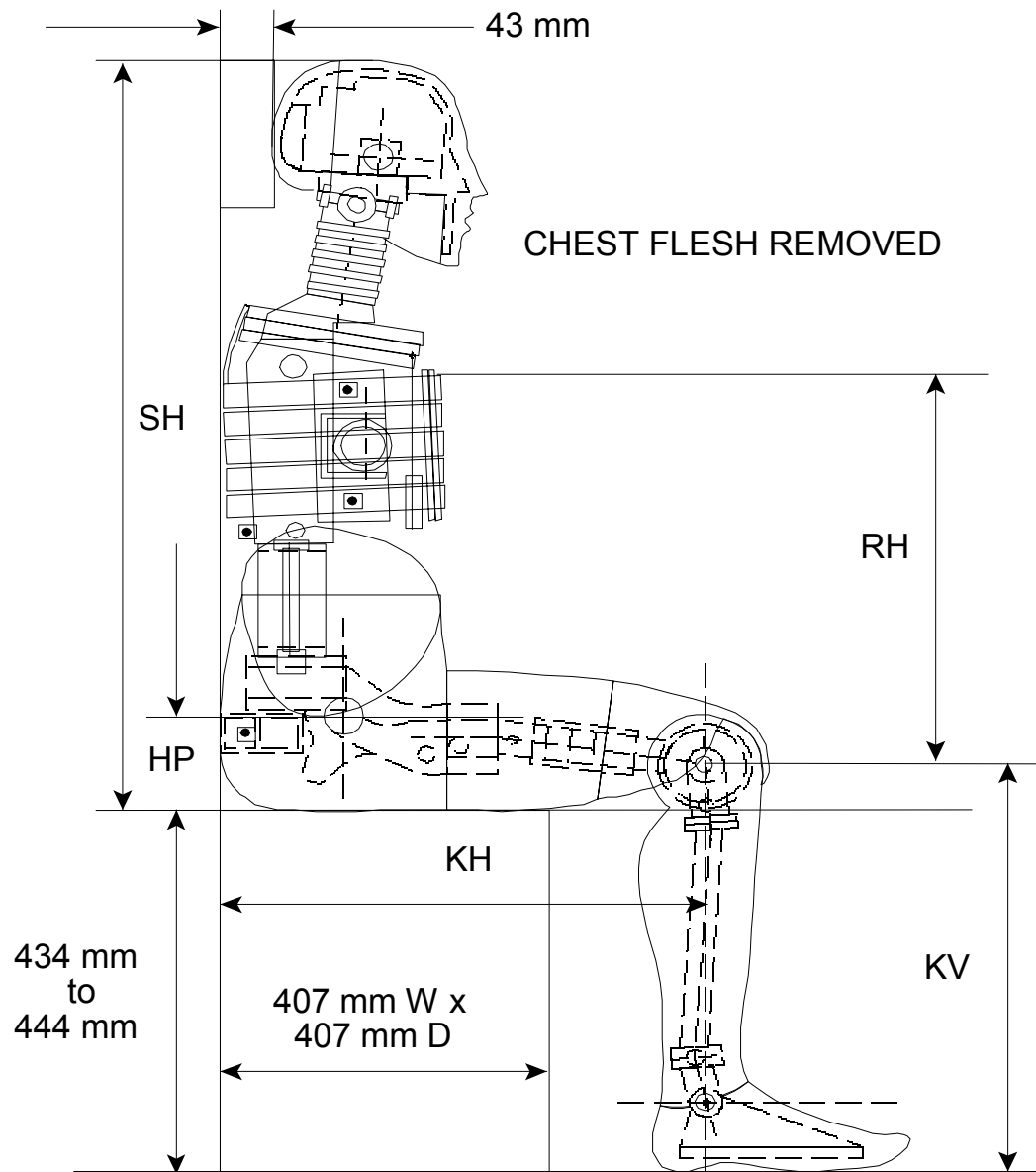

FIGURE 4

16. SID/HIII CONFIGURATION VERIFICATION TESTING....Continued

SID/HIII WITH CHEST FLESH REMOVED

NHTSA DUMMY I.D. NUMBER: _____

DATE OF CONFIGURATION VERIFICATION: _____

SEQUENTIAL VERIFICATION NUMBER FOR DUMMY: _____
 (Sequential number beginning with "1" at the start of each fiscal year's crash test program)

TECHNICIAN: _____

		PART 572M SPECIFICATION	PRETEST	POST TEST
SH	SEATED HEIGHT	889 mm - 909 mm 35.0 in - 35.8 in		
HP	HIP PIVOT HEIGHT	99 mm 3.9 in Ref.		
KH	KNEE PIVOT FROM BACK LINE	511 - 526 20.1 in to 20.7 in		
RH	RIB HEIGHT	502 mm - 520 mm 19.75 in to 20.50 in		
KV	KNEE PIVOT FROM FLOOR	490 mm - 505 mm 19.3 in to 19.9 in		
HW	HIP WIDTH	356 mm - 391 mm 14.0 in to 15.4 in		

17. SID/HIII ACCELEROMETER REQUIREMENTS

HEAD

The SID/HIII head shall be instrumented with three accelerometers to measure orthogonal accelerations (A_x , A_y , and A_z) at the center of gravity of the head assembly. Endevco Model 7231C-750 accelerometers with 1% transverse sensitivity shall be used.

The outputs of the accelerometers shall be recorded in individual data channels. The accelerations shall conform to SAE J211 OCT88 with a channel class of 1000.

CHEST AND PELVIS

Uniaxial Y-direction accelerometers shall be mounted in each of the following locations:

- A. Chest cavity upper rib
- B. Chest cavity lower rib
- C. Chest cavity lower spine
- D. Pelvic assembly

The outputs of the accelerometers shall be recorded in individual data channels. The impact pendulum accelerations shall conform to SAE J211 1/2 MAR95 with a channel class of 60. The pelvis and chest accelerations must conform to a Finite Impulse Response (FIR) filter with a passband frequency of 100 Hz, a step band frequency of 189 Hz, a passband ripple of 0.0225 db, and a stepband gain of -50 db (FIR 100).

- A. The chest cavity Y-Acceleration peak response range requirements are as follows (FIR based numbers):
 - (1) Chest cavity upper rib Y-Acceleration -- 37 to 46 g's
 - (2) Chest cavity lower rib Y-Acceleration -- 37 to 46 g's
 - (3) Chest cavity lower spine Y-Acceleration -- 15 to 22 g's

17. SID/HIII ACCELEROMETER REQUIREMENTS....Continued

B. The pelvis Y-Acceleration peak response range requirement is as follows:

Pelvis Y-Acceleration -- 40 to 60 g's

SID/HIII # _____ TEST PARAMETERS	PART 572M SPECIFICATION	PRETEST CALIBRATION	POST TEST CALIBRATION
HEAD DROP LATERAL IMPACT TEST			
Peak Resultant Accel.	120 - 150 g's		
NECK PENDULUM LATERAL TEST			
Max. D-Plane Rotation	64 - 78 degrees		
Max. Occipital Moment	88 -108 Nm		
THORAX IMPACT TEST			
Upper Rib Accel.	37 - 46 g's		
Lower Rib Accel.	37 - 46 g's		
Lower Spine Accel.	15 - 22 g's		
PELVIC IMPACT TEST			
Pelvic Accel.	40 - 60 g's		

18. SID/HIII PERFORMANCE VERIFICATION TESTING

The SID/HIII shall conform with all test conditions and performance requirements as follows:

A. HEAD DROP TEST (LATERAL)

- (1) The test objective is to measure the head response to lateral impacts with a hard surface.
- (2) The head assembly consists of the head, Drawing 78051-61X Rev. C with six channel modification, Drawing C-1738, neck transducer structural replacement (78051-383X Rev. P) or six-channel transducer, Drawing C1709, three accelerometers for measuring the resultant head acceleration. The mass of the head assembly is 4.54 ± 0.045 kg (10 ± 0.1 lbs.).

18. SID/HIII PERFORMANCE VERIFICATION TESTING....Continued

- (3) The test fixture consists of a structure to suspend the head assembly and a rigidly supported, flat, horizontal, steel plate, 50 mm \pm 2 mm (2 in \pm 0.08 in) thick and 610 mm \pm 10 mm (24 in \pm 0.4 in) square which has a smooth surface finish of 8 to 80 microinches/inch rms. A surface finish close to 8 micro inch/inch rms is preferred. The suspension system and accelerometer cable masses are to be kept as light as possible to minimize the external forces acting on the head.
- (4) The Data Acquisition System, including transducers, must conform to the requirements of SAE Recommended Practice J211 1/2 MAR95. All data channels are to be filtered using Channel Class 1000.
- (5) TEST PROCEDURE
 - (A) Visually inspect the head skin for cracks, cuts, abrasions, etc. Repair or replace the head skin if abrasions or cuts to the side area are more than superficial. The 1/4 in-20 skull cap screws should be torqued to 18.1 N.m (160 lbf-in.) and 10-24 accelerometer mount cap screws to 7.5 N.m (66 lbf-in.).
 - (B) Soak the head assembly in a controlled environment with a temperature of 18.9EC to 25.6EC (66EF to 78EF) and at a relative humidity from 10% to 70% for a period of at least 4 hours prior to a test. The test environment shall have the same temperature and humidity requirements as the soak environment.
 - (C) Mount the accelerometers [Endevco 7231C-750 with 1% transverse sensitivity] in the head on the horizontal transverse bulkhead so the sensitive axes intersect at the center of gravity (cg) point as defined by Drawing 78051-338. One accelerometer is aligned with the sensitive axis perpendicular to the horizontal bulkhead in the midsagittal plane ("z" axis). The second accelerometer is aligned with the sensitive axis parallel to the horizontal bulkhead in the midsagittal plane ("x" axis). The third accelerometer is

18. SID/HIII PERFORMANCE VERIFICATION TESTING....Continued

aligned with the sensitive axis parallel to the horizontal bulkhead and perpendicular to the midsagittal plane ("y" axis). Ensure all transducers are properly installed, oriented and calibrated.

- (D) Clean the impact surface of the skin and the impact plate surface with isopropyl alcohol, trichlorethane or equivalent prior to the test. The impact surface and the skin must be clean and dry prior to the test. There should not be any type of lubricant used between the skull and skin.
 - (E) Suspend the head in a manner such that the midsagittal plane makes an angle of $35^\circ \pm 1^\circ$ with the impact surface and its anterior-posterior axis is horizontal $\pm 1^\circ$. The test setup is shown in Figure 5.
 - (F) Drop the head from a height of $200 \text{ mm} \pm 0.25 \text{ mm}$ ($7.87 \text{ in} \pm 0.01 \text{ in}$), measured from the lowest point on the head, by a means that ensures a smooth, clean release onto the impact surface.
 - (G) Allow a period of at least two hours between successive tests on the same head.
 - (H) All data channels are considered to be at zero level at the time of contact between the head and the impact surface.
- (6) PERFORMANCE SPECIFICATIONS
- (A) When the head is dropped in accordance with paragraph (E) of this section the measured peak resultant acceleration shall be between 120 Gs and 150 Gs.
 - (B) The resultant acceleration-time curve shall be unimodal to the extent that oscillations occurring after the main acceleration vector shall not exceed 15% of the peak resultant acceleration (zero to peak). The longitudinal acceleration vector shall not exceed 15 Gs (zero to peak).

18. SID/HIII PERFORMANCE VERIFICATION TESTING....Continued

B. NECK PENDULUM TEST

- (1) The test objective is to measure the dynamic response of the neck to a lateral impact. The test procedure is similar to that of Part 572 Subpart E, Neck Flexion test, with the entire head and neck assembly rotated 90° to the direction of pendulum motion in order to test the neck in the lateral direction.

HEAD DROP TEST SETUP SPECIFICATION

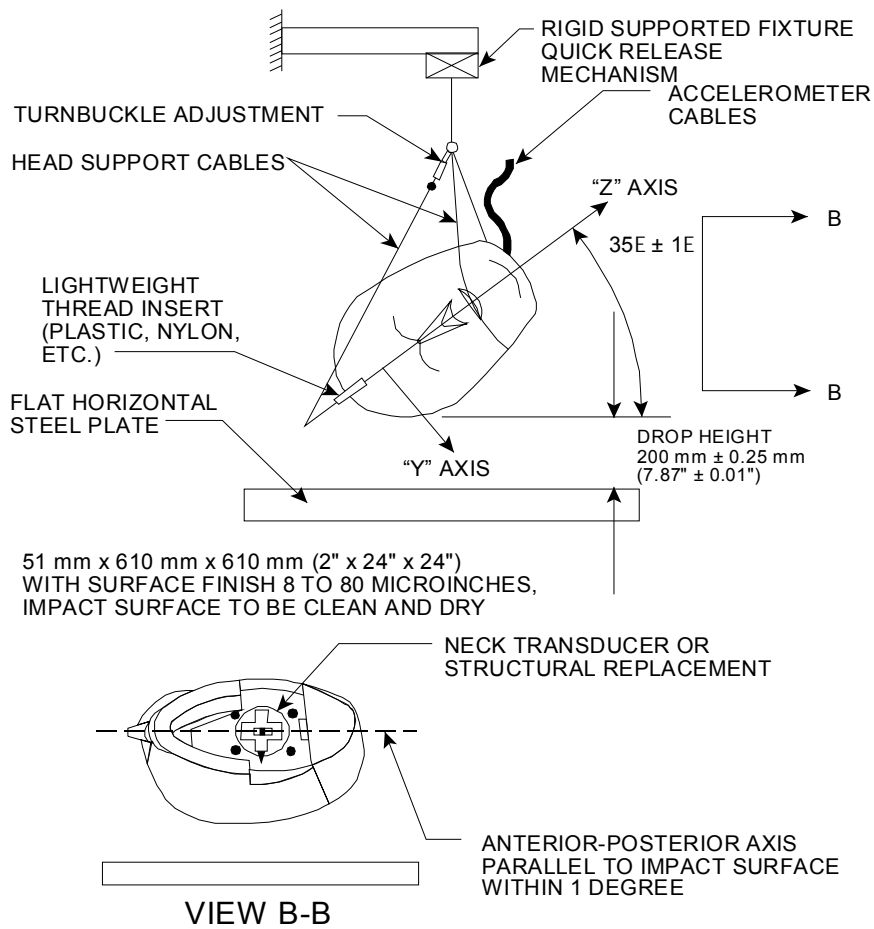

FIGURE 5

18. SID/HIII PERFORMANCE VERIFICATION TESTING....Continued

- (2) The components required for the neck test include the head assembly, Drawing 78051-61X Rev. C, six-channel modification, Drawing C-1709; neck assembly, Drawing 78051-90; upper neck bracket, Drawing 78051-307 Rev. X; and lower neck bracket, Drawing 78051-303 Rev E. Actual accelerometers must be used in the head to maintain the proper mass and center of gravity location. Data from the accelerometers are not required. A six-channel neck transducer is required for measuring the "x" axis moment and the "y" axis force.

The HIII upper and lower neck brackets will be used in the conduct of the neck pendulum lateral impact test ONLY. The neck brackets will be replaced with the modified neck bracket assembly for all other SID/HIII calibrations and during the rigid pole impact test - Appendix C.

- (3) The test fixture pendulum arm with specifications are shown in Figure 6. The aluminum honeycomb material is 1.8 lb/cu-ft with three-fourths (0.75) inch cells. The accelerometer is mounted with its sensitive axis aligned with the arc formed at a radius 65.25 inches from the pivot.
- (4) The Data Acquisition System, including transducers, must conform to the specification of SAE Recommended Practice J211 1/2 MAR95. The neck response data channels are to be filtered using Channel Class 180 and the pendulum acceleration using Channel Class 60.
- (5) TEST PROCEDURE
- (A) Inspect the head and neck for cracks, cuts or other abrasions. Inspect the nodding blocks, Drawing 78051-351 Rev. B. and replace if they are not between 80 and 90 durometer Shore A. Inspect the nodding joint washers, Drawing 78051-253 Rev. A, for an interference fit.

18. SID/HIII PERFORMANCE VERIFICATION TESTING....Continued

- (B) Soak the head and neck assemblies in a controlled environment with a temperature of 20.6°C to 22.2°C (69°F to 72°F) and a relative humidity of 10% to 70% for a period of four (4) hours prior to a test. The test environment shall have the same temperature and humidity requirements as the soak environment. Monitor the temperature of the neck by placing a thermosensor into one of the holes in the neck.
- (C) Torque the jam nut, Drawing 78051-64 Rev. A, on the neck cable, Drawing 78051-301 Rev. E, to 1.35 ± 0.27 N.m. (1.0 ± 0.2 ft-lb) before each test.
- (D) Mount the head/neck assembly to the standard Part 572 pendulum test fixture so the midsagittal plane of the head is vertical and perpendicular to the plane of motion of the pendulum's longitudinal centerline. Adjust the neck brackets so the "D" plane is perpendicular to the pendulum centerline. (The "D" plane is the horizontal surface at the base of the skull.) Install the transducers or other devices for measuring the "D" plane rotation with respect to the pendulum centerline. The rotation can be measured by placing a transducer at the occipital condyles and another at the intersection of the centerline of the neck and the line extending from the base of the neck. In order to position a transducer at the occipital condyles, a bracket must be fabricated which mounts to the base of the skull to permit the attachment of the transducer in line with the occipital condyles. The test setup is illustrated in Figures 6 and 7.
- (E) Prior to the test, it may be necessary to slightly precrush the honeycomb material by impacting it lightly with the pendulum until the desired surface is contacting the pendulum striker plate.
- (F) Allow the neck to flex without head or neck contact with any object.
- (G) Allow a period of at least 30 minutes between successive tests on the same neck.

18. SID/HIII PERFORMANCE VERIFICATION TESTING....Continued

- (H) All data channels are to be at the zero level at the time of contact between the pendulum and the honeycomb material (time zero).

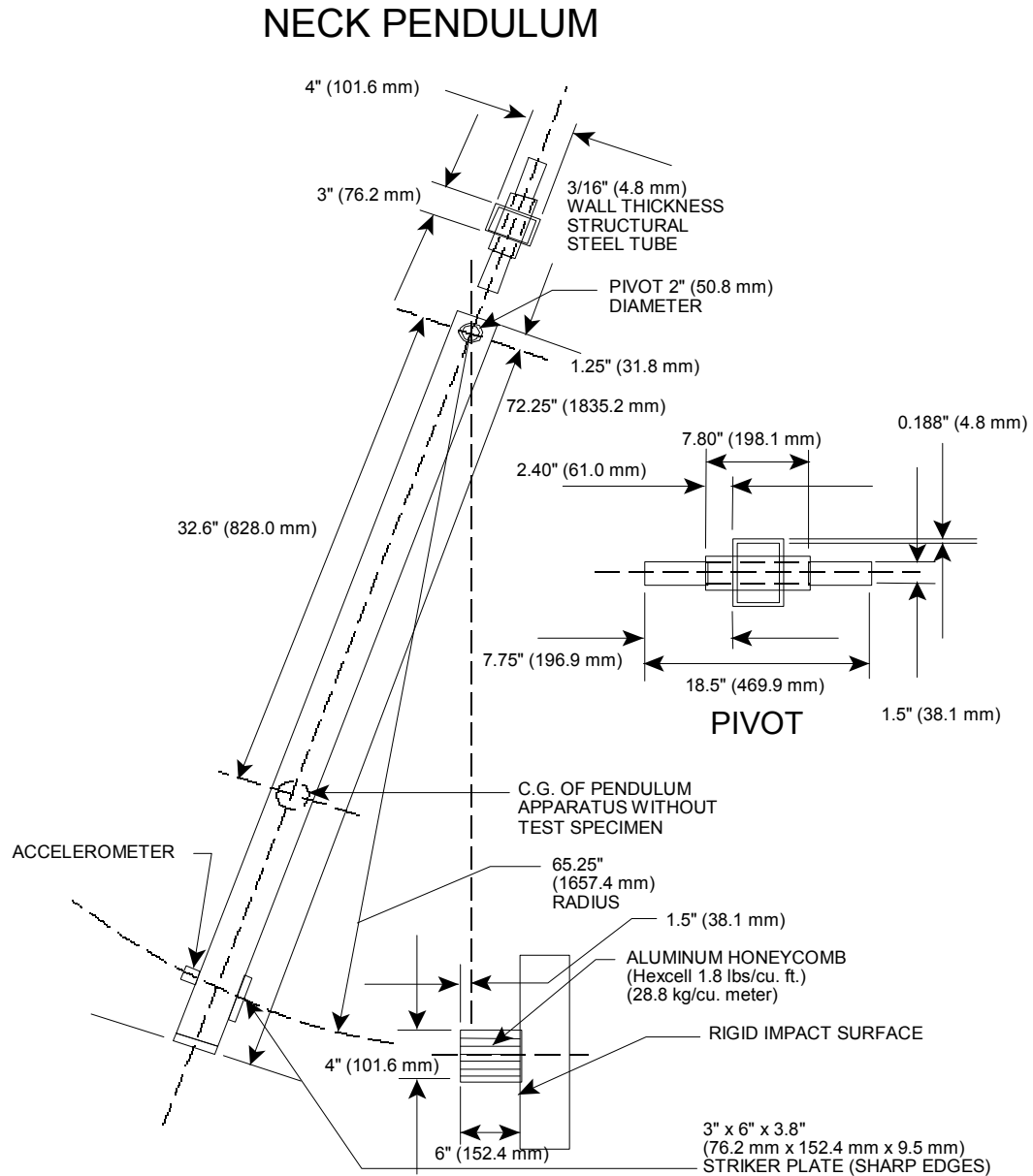

INERTIAL PROPERTIES OF PENDULUM MOUNTING PLATE AND MOUNTING HARDWARE WITHOUT TEST SPECIMEN:
 Weight = 65.2 lbs (29.6 kg)
 Moment of Inertia = 24.5 lb-ft-s² (0.031 Btu - s²) about Pivot Axis

FIGURE 6

18. SID/HIII PERFORMANCE VERIFICATION TESTING....Continued

NECK PENDULUM TEST

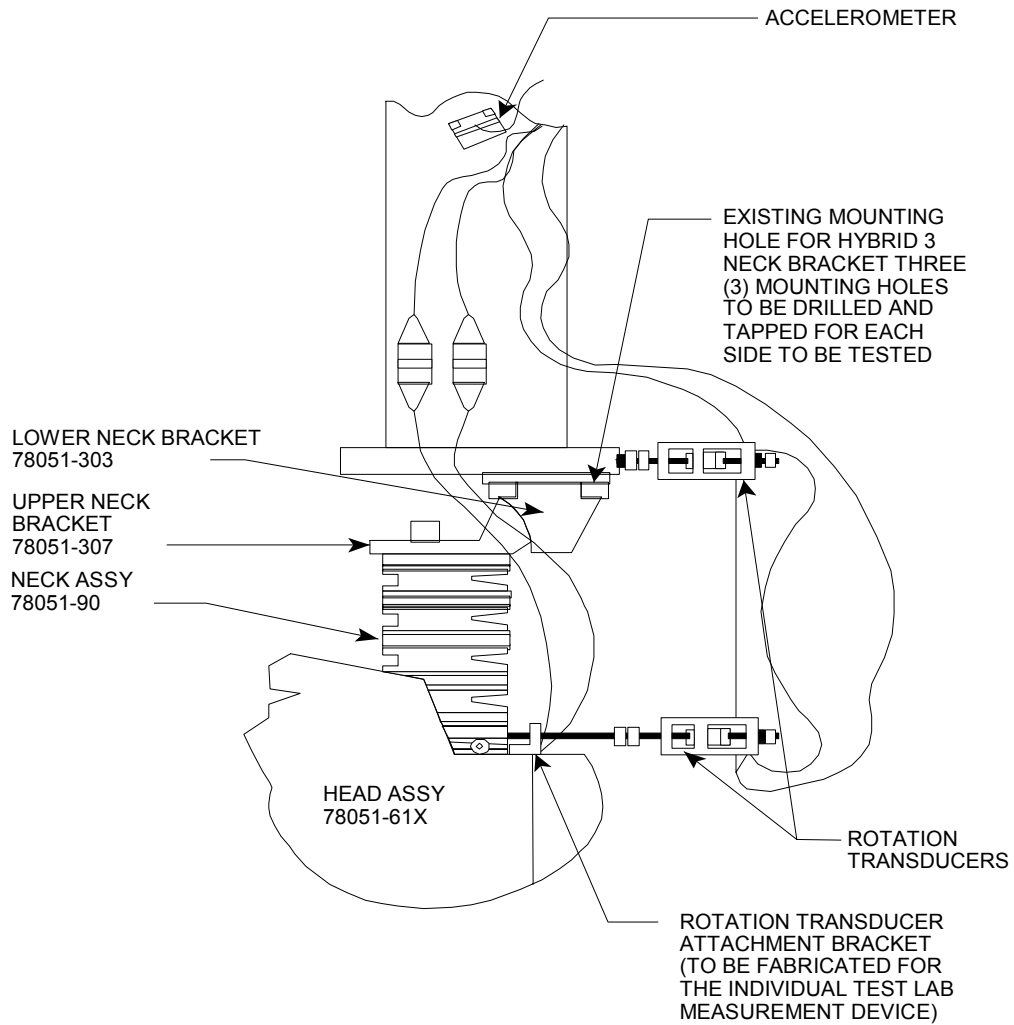

FIGURE 7

18. SID/HIII PERFORMANCE VERIFICATION TESTING....Continued

6. PERFORMANCE SPECIFICATIONS

- (A) Release the pendulum and allow it to fall freely from a height to achieve an impact velocity of 6.89 meters per second (mps) to 7.13 mps (22.6 feet per second (fps) - 23.4 fps) measured at the center of the pendulum accelerometer.
- (B) Time Zero is defined as the time of initial contact between the pendulum striker plate and the honeycomb material.
- (C) Stop the pendulum from the initial velocity with an acceleration vs. time pulse which meets the velocity change as specified below: (integration of the pendulum acceleration data channel is required to obtain the velocity vs. time curve)

TIME (ms)	PENDULUM IMPULSE	
	mps	fps
10	1.96 - 2.55	6.43 - 8.37
20	4.12 - 5.10	13.52 - 16.73
30	5.73 - 7.01	18.80 - 23.0
40-70	6.27 - 7.64	20.57 - 25.06

- (D) The maximum rotation of the midsagittal plane of the head shall be 64E to 78E with respect to the pendulum. The decaying head rotation vs. time curve shall cross the zero angle between 50 milliseconds (ms) and 70 ms after reaching its peak value.
- (E) The moment about the "x" axis which lies in the midsagittal plane of the head at the level of the occipital condyles, shall have a maximum value between 88 and 108 N.m (65 and 80 lbf-ft). The decaying moment vs. time curve shall first cross zero between 40 ms and 60 ms after reaching its peak value.
- (F) The maximum rotation of the head with respect to the pendulum shall occur between 0 ms and 20 ms after the peak moment.

18. SID/HIII PERFORMANCE VERIFICATION TESTING....Continued

- (G) Calculate the moment about the occipital condyles using the six channel neck transducer by the following formula:

METRIC UNITS

Moment= $Mx + (0.01778 \text{ m}) (Fy)$

Mx= moment in N.m measured by the transducer

m = meters

Fy= force in N's measured by the transducer

ENGLISH UNITS

Moment= $Mx + (0.05833 \text{ ft.}) (Fy)$

Mx= moment in lbf-ft. measured by the transducer

ft= feet

Fy= force in lbs measured by the transducer

NOTE: The formulae are based on the sign convention contained in SAE Recommended Practice J211 1/2 MAR95 - Instrumentation For Impact Test

C. THORAX

- (1) Three accelerometers are mounted in the thorax for measurement of lateral accelerations with each accelerometer's sensitive axis aligned to be closely perpendicular to the thorax's midsagittal plane. The accelerometers are mounted in the following locations:
- (A) One accelerometer is mounted on the Thorax to Lumbar Adaptor (SID-005) by means of a T₁₂ Accelerometer Mounting Platform (SID-009) and T₁₂ Accelerometer Mount (SID-038) with its seismic mass center at any distance up to 10 mm (0.4 in) from a surface point on the Thorax to Lumbar Adaptor where two perpendicular planes aligned with the adaptor's vertical and horizontal center lines intersect.
- (B) Two accelerometers are mounted, one on the top and the other at the bottom part of the Rib Bar (SID-024) on the struck side. Their seismic mass centers are at any distance up to 10 mm (0.4 in) from a point on the Rib Bar surface located on its longitudinal centerline 19 mm (0.75 in) from the top for the top accelerometer and 19 mm (0.75 in) from the bottom, for the bottom accelerometer.

18. SID/HIII PERFORMANCE VERIFICATION TESTING....Continued

When the thorax of a completely assembled SID/HIII appropriately assembled for RIGHT or LEFT side impact, is impacted (see figure on next page) by a test probe, specified in the next paragraph, at $4.27 \text{ m/s} \pm 0.06 \text{ m/s}$ (14 feet per second (fps), $\pm 0.2 \text{ fps}$), the peak accelerations at the locations of the accelerometers mounted on the thorax are as follows in items (A), (B) and (C).

The test probe used for lateral thoracic and pelvis impact tests is a $152.4 \text{ mm} \pm 0.25 \text{ mm}$ ($6 \pm 0.01 \text{ in}$) diameter cylinder that weighs $23.36 \text{ kg} \pm 0.02 \text{ kg}$ ($51.5 \text{ lb} \pm 0.05 \text{ lb}$) including instrumentation. Its impacting end has a flat right angle face that is rigid and has an edge radius of 13 mm (0.5 in).

- (A) For the lower thoracic spine (T_{12}) not less than 15 g's and not more than 22 g's.
- (B) For the accelerometer at the top of the Rib Bar on the struck side (LUR for left side or RUR for right side) not less than 37 g's and not more than 46 g's.
- (C) For the accelerometer at the bottom of the Rib Bar on the struck side (LLR for left side or RLR for right side) not less than 37 g's and not more than 46 g's.

(2) Test Procedure.

- (A) Adjust the dummy legs as follows:

Limb joints of the test dummy are set at the force between 1 and 2 g's, which just supports the limbs' weight when the limbs are extended horizontally forward. The force required to move a limb segment does not exceed 2 g's throughout the range of limb motion. See Section 1.8 of the SID/HIII Users Manual for more details.

Seat the dummy on a seating surface as follows with the limbs extended horizontally forward.

- (l) The dummy is placed on a flat, rigid, clean, dry, horizontal smooth aluminum surface whose length

18. SID/HIII PERFORMANCE VERIFICATION TESTING....Continued

and width dimensions are not less than 407 mm (16 in), so that the dummy's midsagittal plane is vertical and centered on the test surface. The dummy's torso is positioned to meet the requirements of Sections A and B (from Section 15 "Upright Seated Position for SID/HIII"). The seating surface is without the back support and the test dummy is positioned so that the dummy's midsagittal plane is vertical and centered on the seat surface.

- (ii) The legs are positioned so that their centerlines are in planes parallel to the midsagittal plane.
 - (iii) Performance pretests of the assembled dummy are separated in time by a period of not less than 20 minutes unless otherwise specified.
- (B) Place the longitudinal centerline of the test probe at the lateral side of the chest at the intersection of the centerlines of the THIRD rib and the Rib Bar on the desired side of impact. This is the left side if the dummy is to be used on the driver's side of the vehicle and the right side if the dummy is to be used on the passenger side of the vehicle. The probe's centerline is perpendicular to thorax's midsagittal plane.
- (C) Align the test probe so that its longitudinal centerline coincides with the line formed by the intersection of the transverse and frontal planes perpendicular to the chest's midsagittal plane passing through the designated impact point.
- (D) Position the SID/HIII as previously specified in Section (A)(from Section 15 "Upright Seated Position for SID/HIII"), so that the thorax's midsagittal plane and tangential plane to the Hinge Mounting Block (Drawing SID-034) are vertical.
- (E) Position the dummy such that the ribs are level horizontally (fore and aft, $\pm 1E$) and the midsagittal plane (as measured from the SID/HIII's ribs) of the dummy is vertical and perpendicular ($\pm 1E$) to the probes centerline.

18. SID/HIII PERFORMANCE VERIFICATION TESTING....Continued

- (F) Impact the thorax with the test probe so that at the moment of impact at the designated impact point, the probe's longitudinal centerline falls within 2 degrees of a horizontal line perpendicular to the dummy's midsagittal plane and passing through the designated impact point.
- (G) Guide the probe during impact so that it moves with no significant lateral, vertical or rotational movement.
- (H) Allow a time period of at least 20 minutes between successive tests of the chest.

D. LUMBAR SPINE AND PELVIS

- (1) The pelvis of a fully assembled SID/HIII shall be impacted laterally by a test probe conforming to the following specifications:

The test probe used for lateral thoracic and pelvis impact tests is a 152.4 mm \pm 0.25 mm (6 in \pm 0.01 in) diameter cylinder that weighs 23.36 kg \pm 0.02 kg (51.5 lb \pm 0.05 lb) including instrumentation. Its impacting end has a flat right angle face that is rigid and has an edge radius of 13 mm (0.5 in).

An accelerometer shall be mounted in the pelvis cavity as follows:

One uniaxial accelerometer is mounted in the pelvis for measurement of the lateral acceleration with its sensitive axis perpendicular to the pelvic midsagittal plane. The accelerometer is mounted on the rear wall of the instrument cavity (Drawing SID-087), with its seismic mass center located up to 8 mm (0.30 in) from the point, 23 mm (0.90 in) upward and 13 mm (0.50 in) to the left of the mounting bolt centerline and 10 mm to 13 mm (0.40 in to 0.50 in) rearward of the rear wall of the instrument cavity.

When the pelvis is impacted laterally at 4.27 m/s \pm 0.06 m/s (14 fps \pm 0.2 fps), in accordance with paragraph (2) of this section, the peak acceleration at the location of the accelerometer mounted in the pelvis cavity shall be not less than 40 g's and not more than 60 g's. The acceleration-time (a-t) curve for the test shall be unimodal (to the extent that oscillations occurring after the main acceleration pulse of the FIR filtered data are less than 10 percent (zero to

18. SID/HIII PERFORMANCE VERIFICATION TESTING....Continued

peak) of the main pulse) and shall lie at or above the + 20 g level for an interval not less than 3 milliseconds (ms) and not more than 7 ms. See Figure 10 for EXAMPLE of TYPICAL curve.

LEFT SIDE CHEST LATERAL IMPACT TEST SETUP

LINEAR IMPACTOR SHOWN FOR SCHEMATIC PURPOSES ONLY. OTHER TYPES OF IMPACTORS MAY BE USED AS LONG AS THEY PROVIDE THE SAME ENERGY AND DIRECTION OF FORCE AT IMPACT.

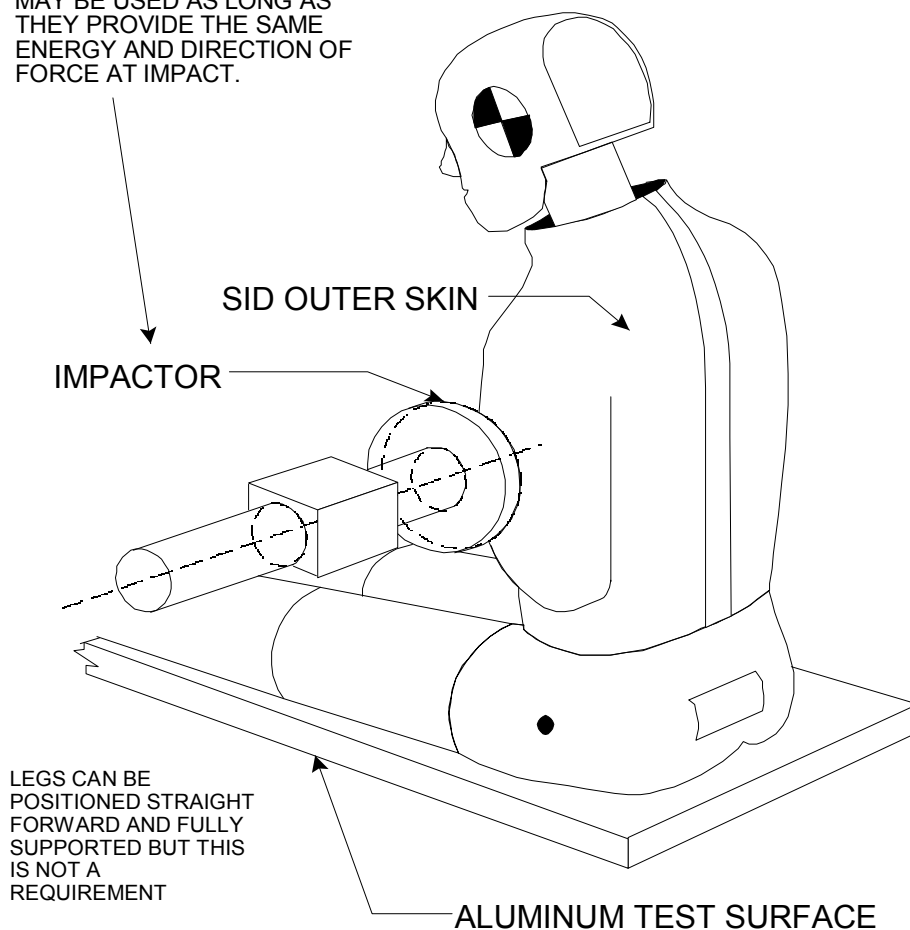
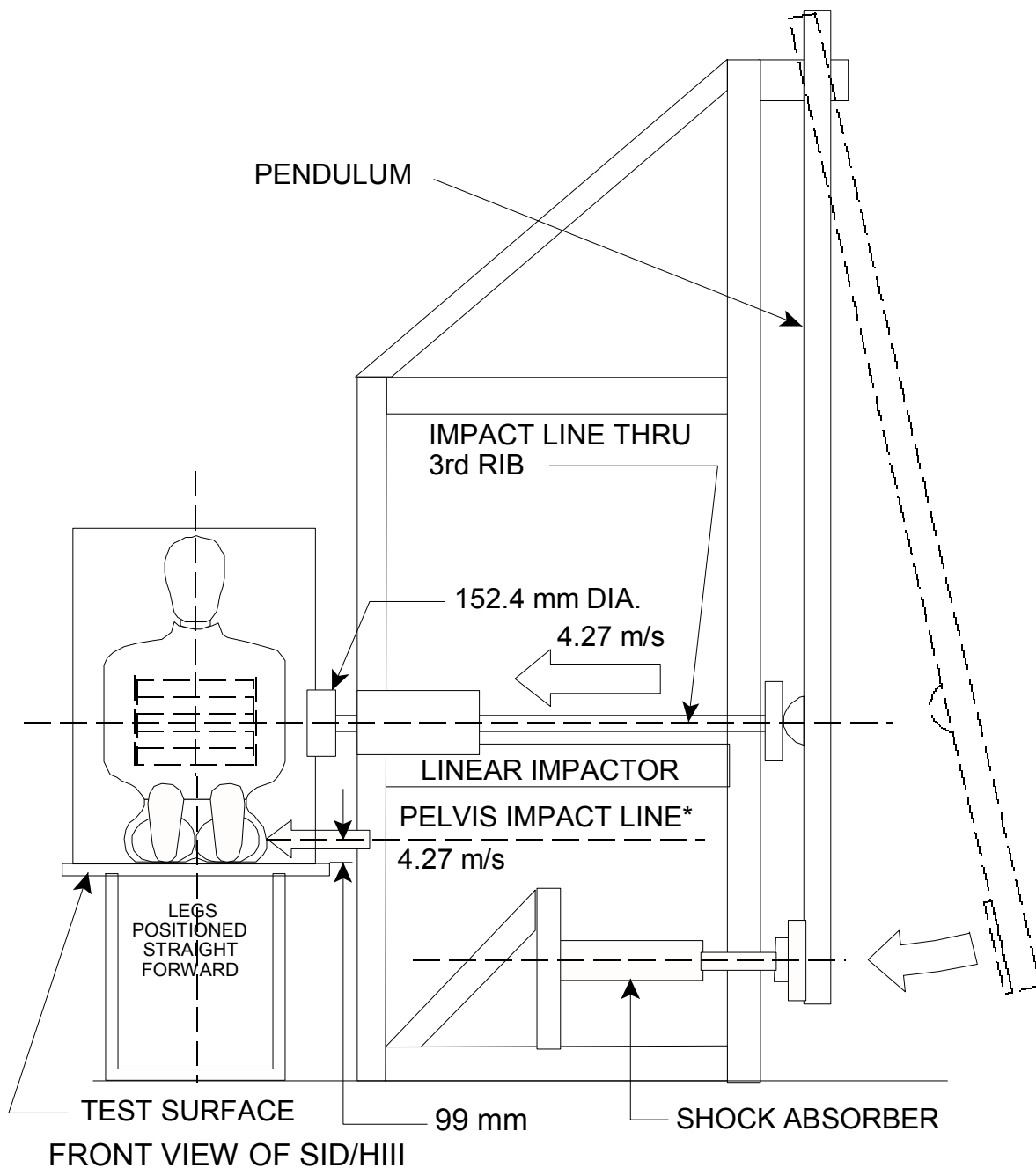

FIGURE 8

18. SID/HIII PERFORMANCE VERIFICATION TESTING....Continued

SID/HIII LINEAR IMPACTOR



* LINE IS 122 mm FORWARD OF TEST SURFACE VERTICAL BACK

FIGURE 9

18. SID/HIII PERFORMANCE VERIFICATION TESTING....Continued

(2) Test Procedure

(A) Adjust the dummy legs as follows:

Limb joints of the test dummy are set at the force between 1 and 2 g's, which just supports the limbs' weight when the limbs are extended horizontally forward. The force required to move a limb segment does not exceed 2 g's throughout the range of limb motion. (Details - see Sect. 1.8 of the SID/HIII users manual).

SID/HIII PELVIS Y-ACCELERATION

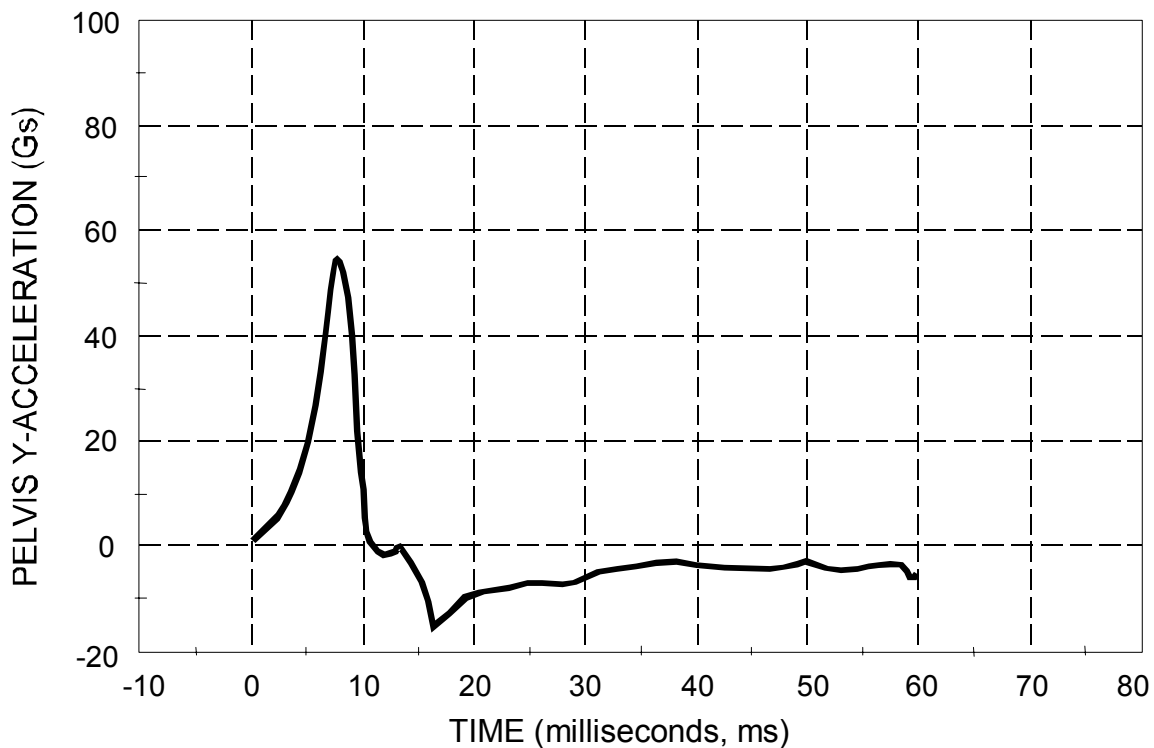

FIGURE 10

Seat the dummy on a seating surface as follows with the limbs extended horizontally forward.

- (I) The dummy is placed on a flat, rigid, clean, dry, horizontal smooth metal surface whose length and width dimensions are not less than 407 mm (16 in), so that the dummy's midsagittal plane is vertical and centered on the test surface. The dummy's torso is positioned to meet the requirements of Sections A

18. SID/HIII PERFORMANCE VERIFICATION TESTING....Continued

and B. The seating surface is without the back support and the test dummy is positioned so that the dummy's midsagittal plane is vertical and centered on the seat surface.

- (ii) The legs are positioned so that their centerlines are in planes parallel to the midsagittal plane.
 - (iii) Performance pretests of the assembled dummy are separated in time by a period of not less than 20 minutes unless otherwise specified.
- (B) Place the longitudinal centerline of the test probe at the lateral side of the pelvis at a point $99 \text{ mm} \pm 1 \text{ mm}$ ($3.9 \text{ in} \pm 0.04 \text{ in}$) vertical from the seating surface and $122 \text{ mm} \pm 1 \text{ mm}$ ($4.8 \text{ in} \pm 0.04 \text{ in}$) ventral to a transverse vertical plane which is tangent to the back of the dummy's buttocks.
- (C) Align the test probe so that at impact its longitudinal centerline coincides with the line formed by intersection of the horizontal and vertical planes perpendicular to the midsagittal plane passing through the designated impact point.
- (D) Adjust the SID/HIII so that its midsagittal plane is vertical and the rear surfaces of the thorax and buttocks are tangent to a transverse vertical plane.
- (E) Orient both the left and right femurs by positioning the centerline of the $\frac{1}{2}$ -13 Shoulder Bolt attaching the upper leg bone to the femur assembly horizontal and perpendicular to the midsagittal plane within one degree.
- (F) Impact the pelvis with the test probe so that at the moment of impact the probe's longitudinal centerline falls within 2 degrees of the line specified as follows:

Align the test probe so that its longitudinal centerline coincides with the line formed by the intersection of the transverse and frontal planes perpendicular to the chest's midsagittal plane passing through the designated impact point.

18. SID/HIII PERFORMANCE VERIFICATION TESTING....Continued

- (G) Guide the test probe during impact so that it moves with no significant lateral, vertical or rotational movement.
- (H) Allow a time period of at least 2 hours between successive tests of the pelvis.

E. INSTRUMENTATION AND TEST CONDITIONS

- (1) The test probe used for lateral thoracic and pelvis impact tests is a 152.4 mm \pm 0.25 mm (6 in \pm 0.01 in) diameter cylinder that weighs 23.36 kg \pm 0.02 kg (51.5 lb \pm 0.05 lb) including instrumentation. Its impacting end has a flat right angle face that is rigid and has an edge radius of 13 mm (0.5 in).
- (2) Three accelerometers are mounted in the thorax for measurement of lateral accelerations with each accelerometer's sensitive axis aligned to be perpendicular to the thorax's midsagittal plane. The accelerometers are mounted in the following locations:
 - (A) One accelerometer is mounted on the Thorax to Lumbar Adaptor (SID-005) by means of a T₁₂ Accelerometer Mounting Platform (SID-009) and T₁₂ Accelerometer Mount (SID-038) with its seismic mass center at any distance up to 10 mm (0.4 in) from a surface point on the Thorax to Lumbar Adaptor where two perpendicular planes aligned with the adaptor's vertical and horizontal center lines intersect.
 - (B) Two accelerometers are mounted, one on the top and the other at the bottom of the Rib Bar (SID-024) on the struck side. Their seismic mass centers are at any distance up to 10 mm (0.4 in) from a point on the Rib Bar surface located on its longitudinal centerline 19 mm (0.75 in) from the top for the top accelerometer and 19 mm (0.75 in) from the bottom, for the bottom accelerometer.
- (3) One uniaxial accelerometer is mounted in the pelvis for measurement of the lateral acceleration with its sensitive axis perpendicular to the pelvic midsagittal plane. The accelerometer is mounted on the rear wall of the instrument cavity (Drawing SID-087), with its seismic mass center located up to 8 mm (0.30 in) from the point, 23 mm (0.90 in) upward and 13 mm (0.50 in) to the

18. SID/HIII PERFORMANCE VERIFICATION TESTING....Continued

left of the mounting bolt centerline and 10 mm to 13 mm (0.40 in to 0.50 in) rearward of the rear wall of the instrument cavity.

- (4) Instrumentation and sensors used must conform to the SAE J211 1/2 MAR95 recommended practice requirements. The outputs of the accelerometers installed in the dummy are then processed with the software for the Finite Impulse Response (FIR) filter (FIR 100 software). The FORTRAN program for this FIR 100 software (FIR 100 Filter Program, Version 1.0, July 16, 1990) is incorporated by reference in 572.40 of Standard 214. The data are processed in the following manner:
 - A. Analog data recorded in accordance with SAE J211 1/2 MAR95 recommended practice channel class 1000 specification
 - B. This data is then filtered with the FIR 100 Filter Program (Version 1.0, July 16, 1990).
 - (1) FIR 100 Filter does the following:
 - A. Filters the data with a 300 Hz, SAE Class 180 filter
 - B. Sub-sample the data to a 1600 Hz sampling rate
 - C. Removes the bias from the sub-sampled data
 - (2) FIR 100 Filter Program has the following characteristics:
 - A. Passband frequency — 100 Hz
 - B. Stopband frequency — 189 Hz
 - C. Stopband gain — 50 db
 - D. Passband ripple — 0.0225 db

18. SID/HIII PERFORMANCE VERIFICATION TESTING....Continued

- (5) The mountings for the spine, rib and pelvis accelerometers shall have no resonance frequency within a range of 3 times the frequency range of the applicable channel class.

19. BENCH TEST PROCEDURE FOR CHEST SHOCK ABSORBER

The following procedure is provided for the bench test.

FILLING AND BLEEDING PROCEDURE FOR THE SID/HIII THORACIC SHOCK ABSORBER

The SID/HIII thoracic shock absorber is manufactured by ACE Controls Inc. (or any shock absorber that fulfills performance requirements) and is specified as

HA - 1/2 x 2-Z ACE Primary Series Linear Decelerator non-adjustable with full open orifices and a double shaft seal

The following industrial oils may be used to fill the shock absorber. Oils from different manufacturers should not be mixed.

American Industrial Oil #46
AMOCO-Dexron Automatic Transmission Fluid
Texaco Regal 46

The following draining, flushing, filling, and bleeding procedure should be performed before a shock absorber is bench tested to check performance. If the oil to be used in bleeding the unit is the same as the oil already in the unit, it is not necessary to drain and flush the shock absorber.

- A. Remove the spring retainer screw, the spring retainer, and the spring from the shaft.
- B. Replace the retainer and the retainer screw.
- C. Remove the drain plug (socket head) and the bleed screw from the shock absorber body.
- D. Drain the oil from the unit.

19. BENCH TEST PROCEDURE FOR CHEST SHOCK ABSORBER....Continued

- E. Check the bleed hole to see if it is clear. If there is black foam blocking the hole, the unit must be disassembled and the foam moved out of the way. See the ACE Controls Installation, Maintenance and Repair Manual for disassembling instructions.
- F. Screw a stand pipe and reservoir into the drain plug opening. A short nipple with a pipe thread on one end and a small cup (approximately 50 mm in diameter and 50 mm high) soldered to the other end is satisfactory.
- G. Fill the cup with clean oil and stroke the piston several times until oil is flowing freely out of the bleed hole. Remove the cup and drain the oil from the shock absorber. Repeat this flushing three times.
- H. Replace the cup and refill it with clean oil. Stroke the unit several times until oil is flowing freely out of the bleed hole. With the piston fully stroked, place a thumb or finger tightly over the bleed hole and draw the piston out slowly. Oil will be drawn in through the stand pipe. Remove the finger and push the piston in slowly forcing oil and air bubbles out of the bleed hole. Be sure there are no air bubbles or contaminants in the reservoir or they will be drawn into the unit. Keep the reservoir full of clean oil. Never pull the shaft out without tightly covering the bleed hole or air will be drawn into the unit. Continue stroking the shock absorber slowly until no air bubbles can be seen emerging from the bleed hole. Even very small bubbles must be eliminated.
- I. Push the piston all the way in and then, without covering the bleed hole, pull the piston out very slowly so that oil continues to flow out of the bleed hole and air is not sucked into the unit. This is best accomplished by rotating the shaft back and forth while gently pulling.
- J. Replace the plug and bleed screw with the piston in the full out position.
- K. Replace the spring.
- L. Bench test the shock absorber.

19. BENCH TEST PROCEDURE FOR CHEST SHOCK ABSORBER....Continued

BENCH TEST PROCEDURE FOR CHEST SHOCK ABSORBER

- A. All air must be bled from shock absorber since air in the system greatly effects resistive force.
- B. Data to be recorded is as follows:
 - (1) Resisting force
 - (2) Shock piston displacement
 - (3) Pendulum acceleration
 - (4) Shock piston velocity
 - (5) Time
- C. Nominal impact velocities shall be 3.05,4.27,6.10 m/s (10, 14 and 20 fps).
- D. A typical schematic of shock absorber test setup is shown in Figure 11. For specific details, refer to drawing number SID-083 (sheets 1 and 2).

19. BENCH TEST PROCEDURE FOR CHEST SHOCK ABSORBER....Continued

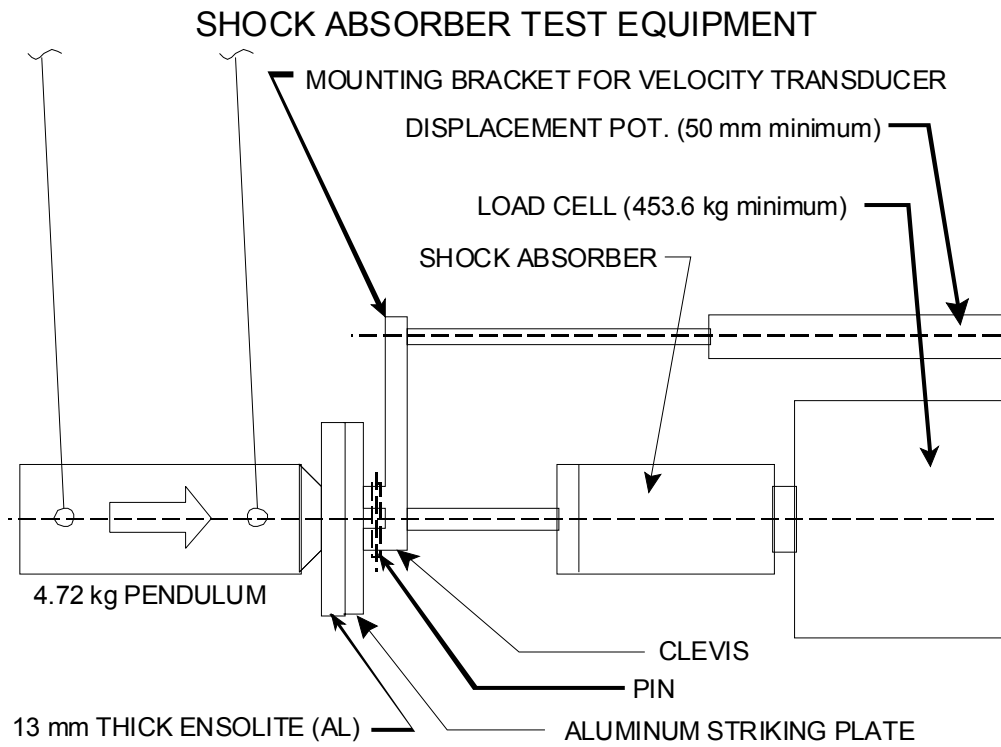

FIGURE 11

19. BENCH TEST PROCEDURE FOR CHEST SHOCK
ABSORBER...Continued

E. Tested units must meet specifications shown in Figure 12:

SPECIFICATIONS FOR SHOCK ABSORBER

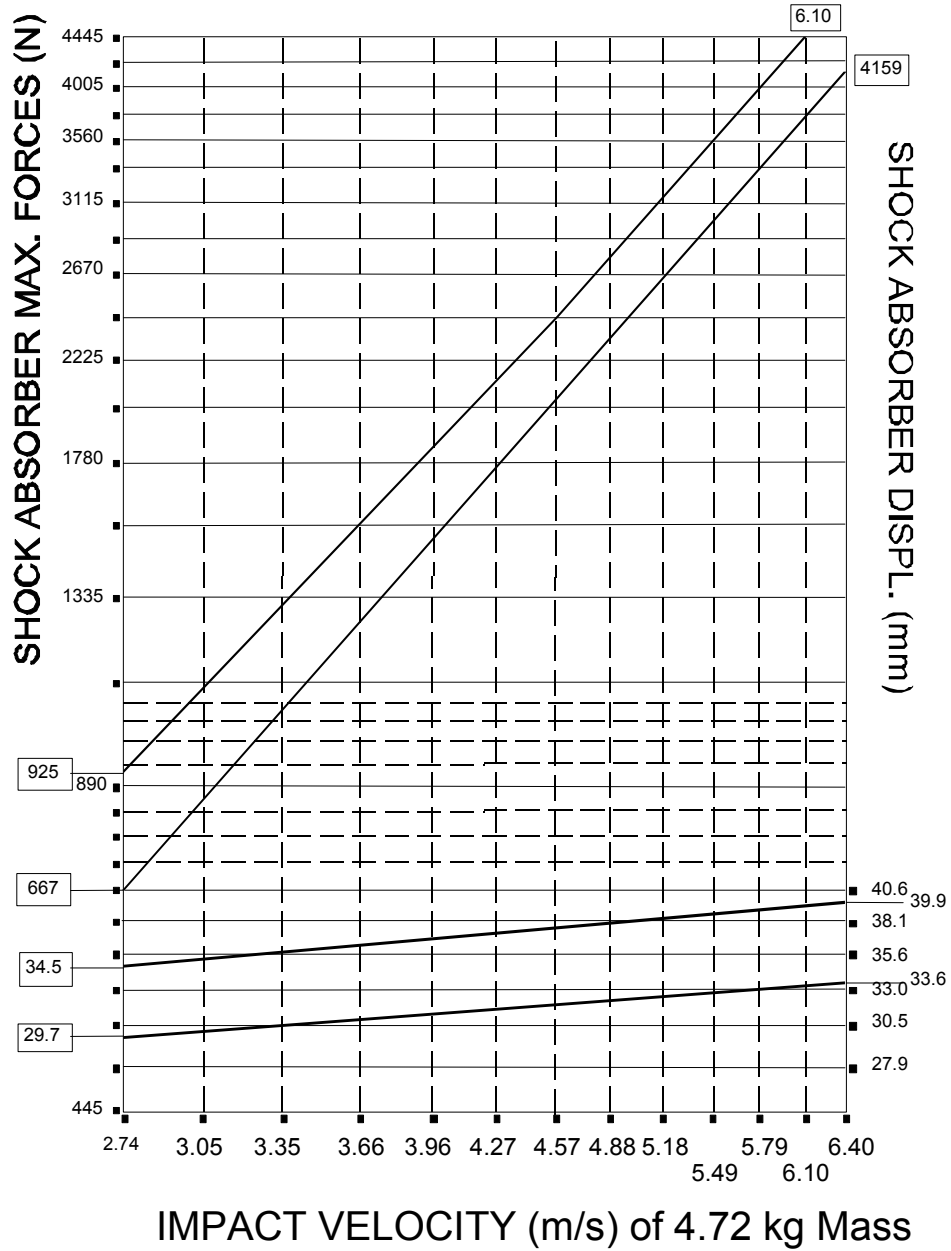

FIGURE 12

20. VERIFICATION TEST DATA SUMMARY SHEET

A test data summary sheet shall be provided.

The data sheet will include the following:

Head Drop Lateral Impact Test Data

Neck Pendulum Lateral Impact Test Data

Thorax Lateral Impact Test Data

Lumbar Spine and Pelvis Lateral Impact Test Data

21. CHEST CAVITY SHOCK ABSORBER BENCH TEST VERIFICATION DATA

One data sheet for the SID/HIII used in each rigid pole side impact protection test.

APPENDIX B
POSITIONING PROCEDURE FOR SIDE IMPACT HYBRID DUMMY (SID/HIII)
TABLE OF CONTENTS

		PAGE
1.	TORSO	
	A. For A SID/HIII In The Driver Position	B2
	B. For A SID/HIII In The Front Outboard Passenger Position.....	B2
2.	PELVIS	
	A. H-Point.....	B3
	B. Pelvic Angle	B3
3.	LEGS	
	A. For A SID/HIII In The Driver Position	B3
	B. For A SID/HIII In The Outboard Passenger Positions	B3
	C. Femur Alignment	B4
4.	FEET	
	A. For A SID/HIII In The Driver Position	B4
	B. For A SID/HIII In The Front Outboard Passenger Position.....	B4

SID/HIII POSITIONING PROCEDURE

The SID/HIII, P572M, is a hybrid dummy in which the SID, P572F, was combined with the HIII head and neck, P572E. A new neck bracket has been designed to preserve the head-neck alignment and ensure that the hybrid dummy is within the seating height of the 50th percentile male and the SID. The SID/HIII initial positioning procedures are identical to the SID procedures of S7 of FMVSS 214. The appropriate sections from the SID positioning procedure are presented here for the purpose of complete reference in the rigid pole side impact test procedure.

Initially position a correctly configured Part 572M Side Impact Hybrid Dummy (SID/HIII) in the front outboard seating position on the side of the test vehicle to be striking the rigid pole. The side impact hybrid dummy is restrained using all available belt systems in all seating positions where such belt restraints are provided. In addition, any folding armrest is retracted.

SID/HIII POSITIONING PROCEDURE....Continued

1. TORSO

A. For a SID/HIII in the Driver Position

(1) For a BENCH SEAT

The upper torso of the SID/HIII rests against the seat back. The midsagittal plane of the SID/HIII is vertical and parallel to the vehicle's longitudinal centerline and passes through the center of the steering wheel.

(2) For a BUCKET OR CONTOURED SEAT

The upper torso of the SID/HIII rests against the seat back. The midsagittal plane of the SID/HIII is vertical and parallel to the vehicle's longitudinal centerline, and coincides with the longitudinal centerline of the bucket seat.

B. For a SID/HIII in the Front Outboard Passenger Position

(1) For a BENCH SEAT

The upper torso of the SID/HIII rests against the seat back. The midsagittal plane of the SID/HIII is vertical and parallel to the vehicle's longitudinal centerline, and the same distance from the vehicle's longitudinal centerline as would be the midsagittal plane of a test dummy positioned in the driver position under item A.

(2) For a BUCKET or CONTOURED SEAT

The upper torso of the SID/HIII rests against the seat back. The midsagittal plane of the SID/HIII is vertical and parallel to the vehicle's longitudinal centerline, and coincides with the longitudinal centerline of the bucket seat.

NOTE: The midsagittal plane of the SID/HIII should have a tolerance of (0 mm, -15 mm) about the longitudinal centerline of the seat. If there is a question concerning the placement of the SID/HIII, the SID/HIII should be placed further away from the impacted door side.

SID/HIII POSITIONING PROCEDURE....Continued

2. PELVIS

A. H-Point

The H-points of each SID/HIII coincide within 13 mm (0.5 in) in the vertical dimension and 13 mm (0.5 in) in the horizontal dimension of a point 6 mm below the position of the H-point determined by using the equipment for the 50th percentile and procedures specified in SAE J826 (1980), except that Table 1 of SAE J826 is not applicable. The length of the lower leg and thigh segments of the H-point machine are adjusted to 414 mm (16.3 in) and 401 mm (15.8 in), respectively.

B. Pelvic Angle

As determined using the pelvic angle gauge (GM drawing 78051-532) which is inserted into the H-point gauging hole of the dummy, the angle of the plane of the surface on the lumbar-pelvic adaptor on which the lumbar spine attaches is 23E to 25E from the horizontal, sloping upward toward the front of the vehicle.

3. LEGS

A. For a SID/HIII in the DRIVER POSITION

The upper legs of each SID/HIII rest against the seat cushion to the extent permitted by placement of the feet. The left knee of the SID/HIII is positioned such that the distance from the outer surface of the knee pivot bolt to the dummy's midsagittal plane is $152 \text{ mm} \pm 2.5 \text{ mm}$ ($6.0 \text{ in} \pm 0.1 \text{ in}$). To the extent practicable, the left leg of the SID/HIII is in a vertical longitudinal plane.

B. For a SID/HIII in the OUTBOARD PASSENGER POSITION

The upper legs of each SID/HIII rest against the seat cushion to the extent permitted by placement of the feet. The initial distance between the outboard knee clevis flange surfaces is $292 \text{ mm} \pm 2.5 \text{ mm}$ ($11.5 \text{ in} \pm 0.1 \text{ in}$). To the extent practicable, both legs of the SID/HIII in outboard passenger positions are in vertical longitudinal planes. Final adjustment to accommodate placement of feet in accordance with Section 4 for various passenger compartment configurations is permitted.

SID/HIII POSITIONING PROCEDURE....Continued

C. Femur Alignment

Orient both the left and right femurs by making the centerlines of the ½-13 Shoulder Bolt attaching the upper leg bone to the femur assembly horizontal and perpendicular to the midsagittal plane within 1°.

Suggested Procedure for Adjusting Centerlines of Bolts

Place a Femur Alignment Tool (shown on next two pages) through the hole on each side of the pelvis into the socket of the ½-13 Shoulder Bolt (Reference Figure 44 or Figure 56 of the SID User's Manual - July 1990). To account for the looseness of fit of the wrench in the socket head, determine the average of the angles of the wrench from horizontal when it is lifted upward with a minimum force and resting in a downward position. Adjust the femur by moving the allen wrench so that the average angle is set to zero for the horizontal angle and parallel to a transverse plane.

NOTE: If another tool can be used to more easily align the femur, then it may be used after final approval by the COTR.

For reference, the centerlines of the 3/8-16 bolts connecting the upper knee post to the upper knee bone should be in planes parallel to the vertical longitudinal plane of the test vehicle and 188 mm (7.4 in) apart.

4. FEET

A. For a SID/HIII in the DRIVER POSITION

The right foot of the SID/HIII rests on the undepressed accelerator with the heel resting as far forward as possible on the floorpan. The left foot is set perpendicular to the lower leg with the heel resting on the floorpan in the same lateral line as the right heel.

B. For a SID/HIII in the FRONT OUTBOARD PASSENGER POSITION

The feet of the SID/HIII are placed on the vehicle's toeboard with the heels resting on the floorpan as close as possible to the intersection of the toeboard and floorpan. If the feet cannot be placed flat on the toeboard, they are set perpendicular to the lower legs and placed as far forward as possible so that the heels rest on the floorpan.

SID/HIII POSITIONING PROCEDURE....Continued

SID/SIDH3 FEMUR ALIGNMENT TOOL

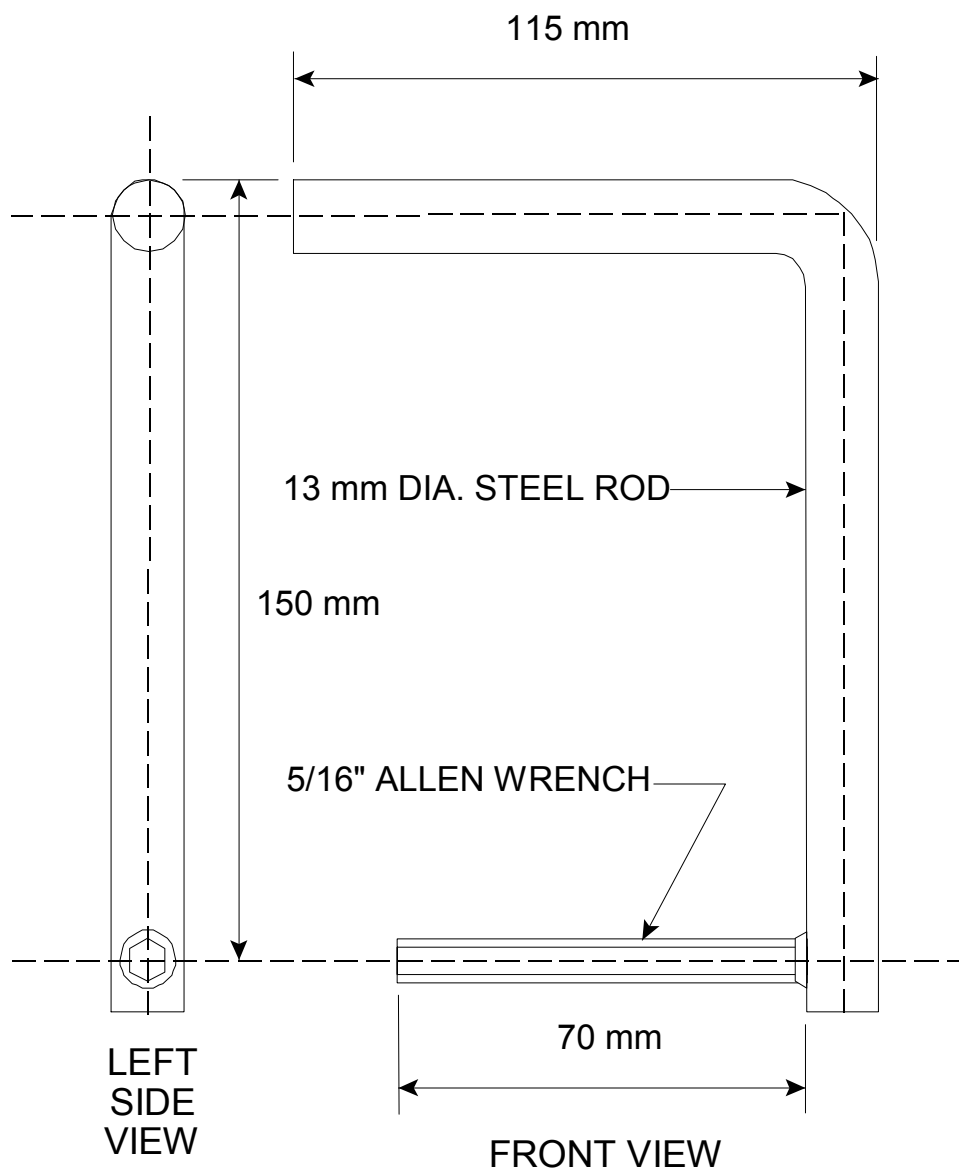

FIGURE 1

SID/HIII POSITIONING PROCEDURE....Continued

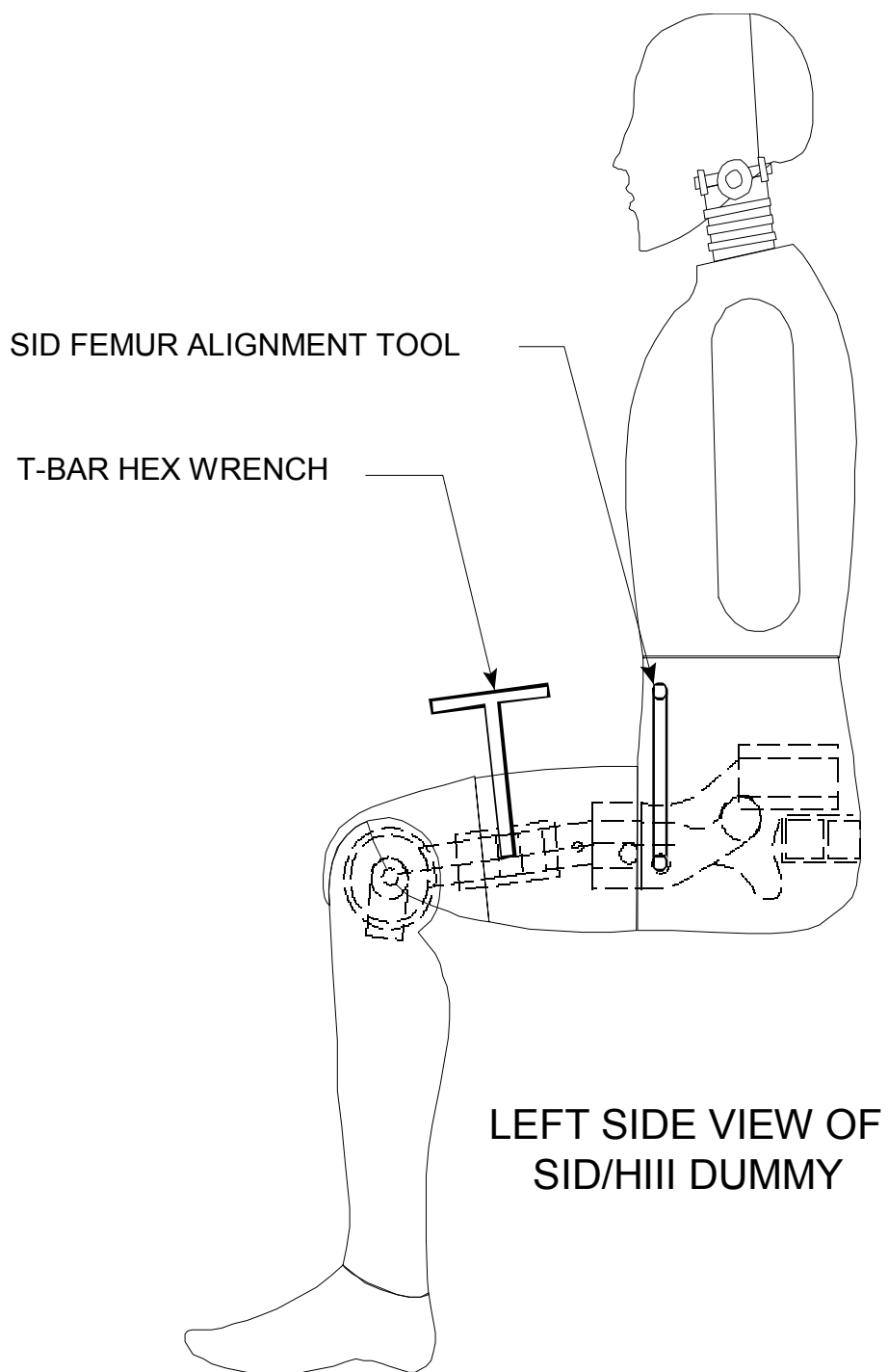
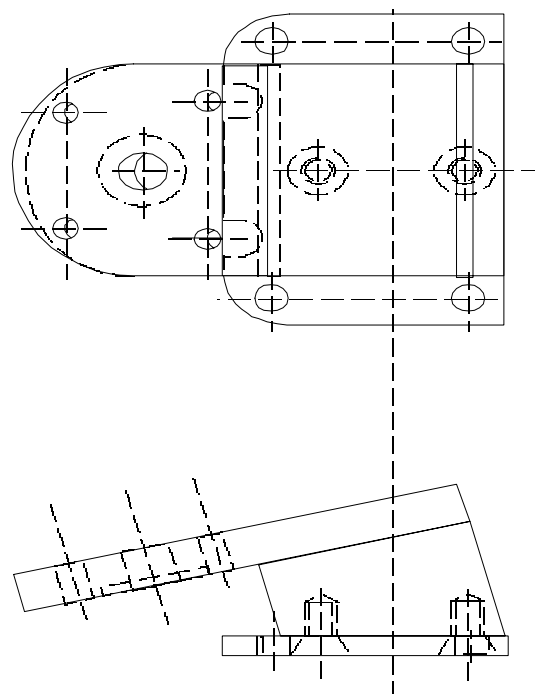

FIGURE 2

APPENDIX C
HEAD-NECK BRACKET ASSEMBLY

HEAD NECK BRACKET ASSEMBLY



NOTE:
 ALL FILLET WELDS
 .250/6.35 UNLESS
 OTHERWISE NOTED.
 Optional one-piece
 construction for support
 and upper base.

FIGURE 1

HEAD NECK BRACKET, UPPER BASE

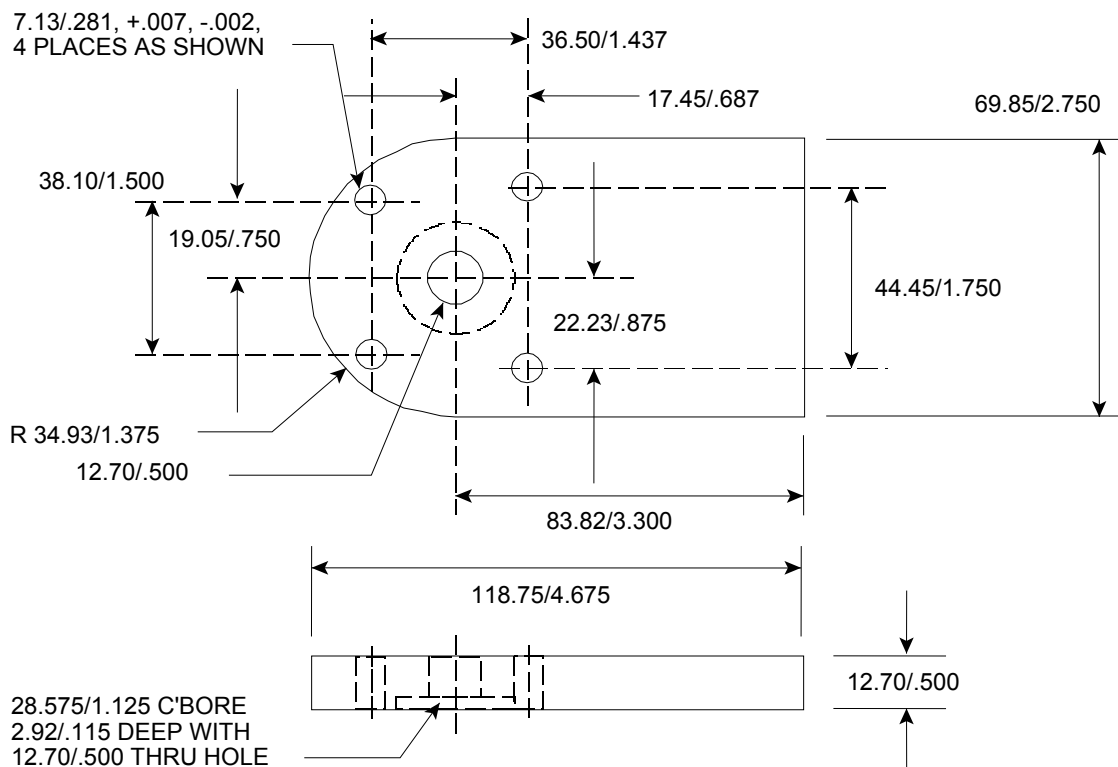

FIGURE 2

APPENDIX C...Continued

HEAD NECK BRACKET, SUPPORT

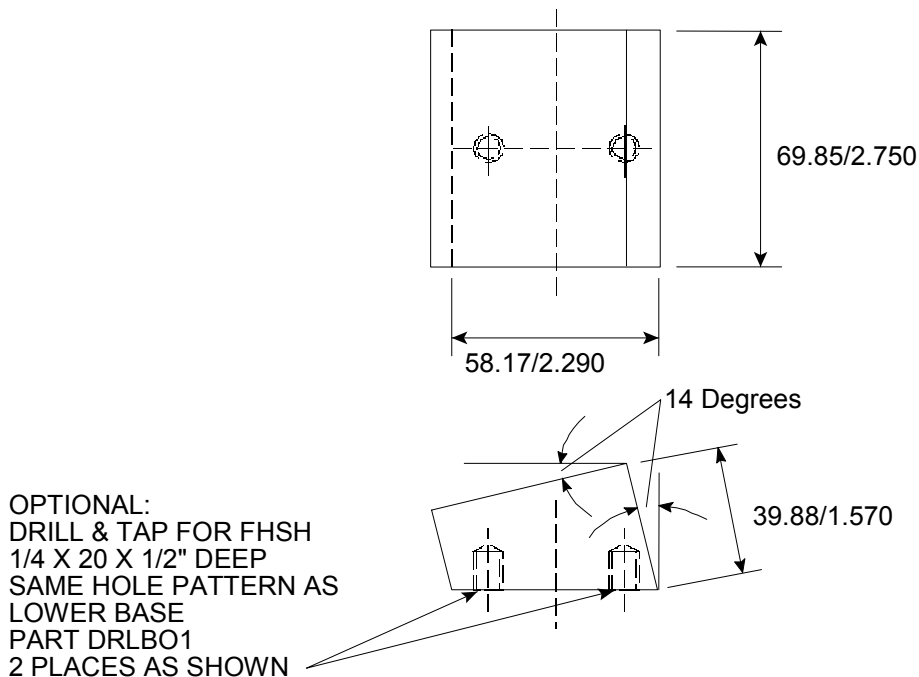

FIGURE 3

HEAD-NECK BRACKET, LOWER BASE

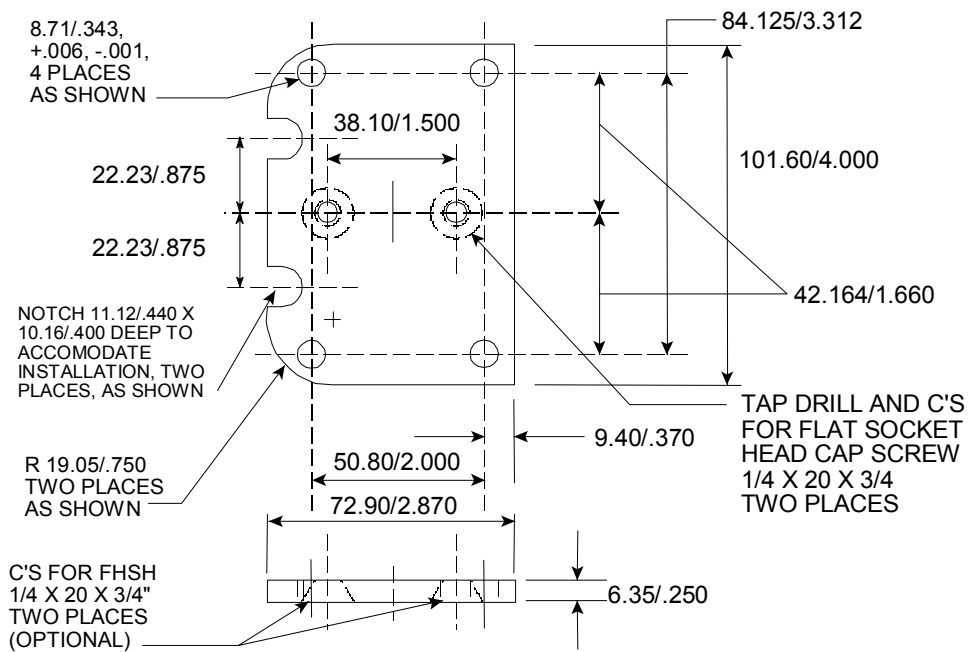

FIGURE 4