

[54] VEHICLE WHEEL

- [75] Inventor: Edward T. Welburn, Detroit, Mich.
- [73] Assignee: General Motors Corporation, Detroit, Mich.
- [**] Term: 14 Years
- [21] Appl. No.: 42,064
- [22] Filed: May 24, 1979
- [51] Int. Cl. D12-16
- [52] U.S. Cl. D12/209
- [58] Field of Search D12/209, 211; 301/63 R, 301/64 R, 64 SD, 65, 66

[56] **References Cited**
U.S. PATENT DOCUMENTS

D. 246,239 11/1977 Kozloski D12/209

OTHER PUBLICATIONS

Motor Trend, 4/78, p. 56, Wheel on Volvo, bottom of page.
 1977 Oldsmobile Supplement to the Washington Post, p. 3, Wheel on Delta 88, Box 1, center of page.

Primary Examiner—James M. Gandy
 Attorney, Agent, or Firm—Herbert Furman

[57] CLAIM

The ornamental design for a vehicle wheel, as shown and described.

DESCRIPTION

FIG. 1 is a front elevational view of a vehicle wheel; FIG. 2 is a sectional view thereof taken generally along the plane indicated by line 2—2 of FIG. 1; and FIG. 3 is a fragmentary perspective view thereof, it being understood that the remaining portions of the wheel are omitted for convenience of illustration.

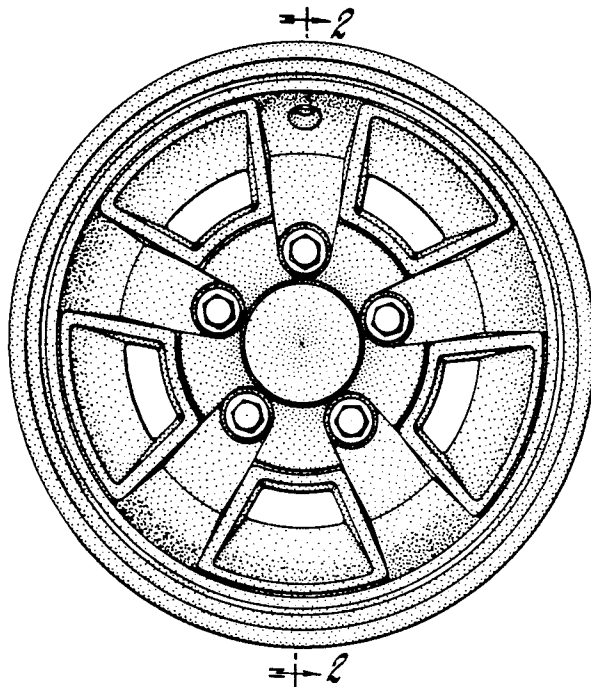

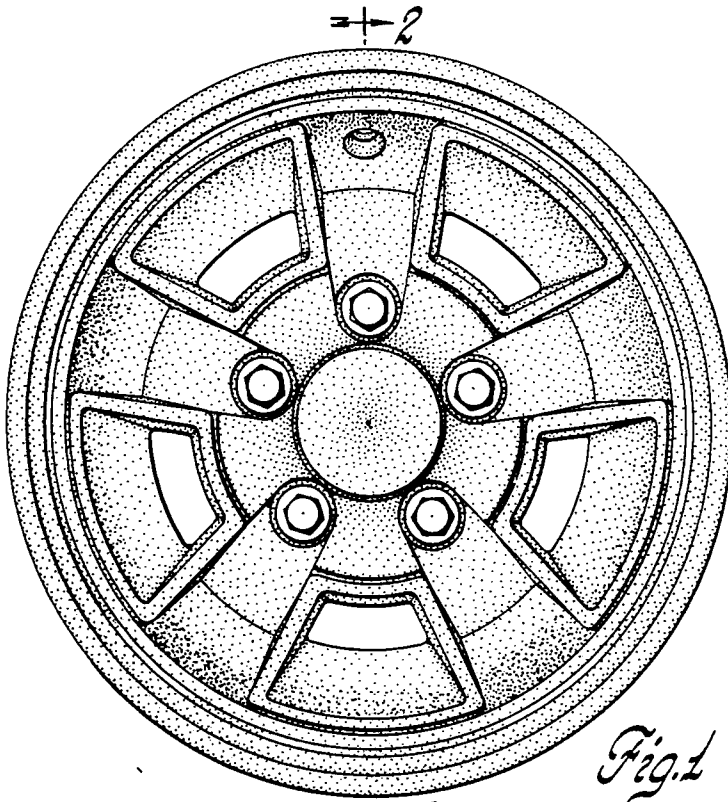

Fig. 1

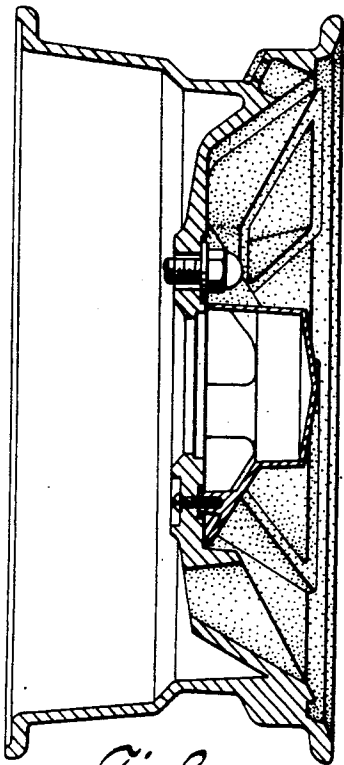

Fig. 2

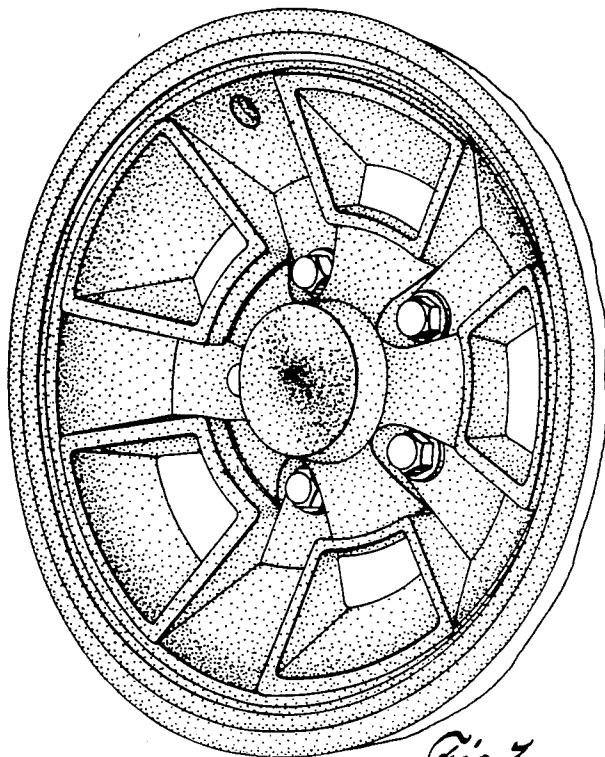

Fig. 3

UNITED STATES PATENT AND TRADEMARK OFFICE
CERTIFICATE OF CORRECTION

PATENT NO. : D-259,484

DATED : June 9, 1981

INVENTOR(S) : Edward T. Welburn

It is certified that error appears in the above-identified patent and that said Letters Patent are hereby corrected as shown below:

Title Page, column 1, [**] Term: 14 years should
read -- [**] Term: 7 years -- .

Signed and Sealed this

Fifteenth Day of September 1981

[SEAL]

Attest:

GERALD J. MOSSINGHOFF

Attesting Officer

Commissioner of Patents and Trademarks