



US00D671034S

(12) **United States Design Patent**  
**Bischoff et al.**

(10) **Patent No.:** **US D671,034 S**

(45) **Date of Patent:** **\*\* Nov. 20, 2012**

(54) **MOTOR VEHICLE**

(75) Inventors: **Klaus Bischoff**, Evessen (DE); **Oliver Stefani**, Vechelde-Wahle (DE); **Marco Antonio Pavone**, Wolfsburg (DE)

(73) Assignee: **Volkswagen AG**, Wolfsburg (DE)

(\*\*) Term: **14 Years**

(21) Appl. No.: **29/402,454**

(22) Filed: **Sep. 23, 2011**

(30) **Foreign Application Priority Data**

Apr. 12, 2011 (WO) ..... 597 886 901

(51) **LOC (9) Cl.** ..... **12-08**

(52) **U.S. Cl.** ..... **D12/91**

(58) **Field of Classification Search** ..... D12/86,  
D12/90-92, 99; D21/424, 433, 434; 296/181.1,  
296/181.5

See application file for complete search history.

(56) **References Cited**

**U.S. PATENT DOCUMENTS**

D583,709 S \* 12/2008 Bischoff et al. .... D12/90

D584,189 S \* 1/2009 Bischoff et al. .... D12/91

D620,394 S \* 7/2010 Bischoff et al. .... D12/91  
D620,840 S \* 8/2010 Bischoff et al. .... D12/91  
D621,300 S \* 8/2010 Bischoff et al. .... D12/92  
D626,885 S \* 11/2010 Bischoff et al. .... D12/91  
D647,820 S \* 11/2011 Jang ..... D12/91

\* cited by examiner

*Primary Examiner* — Melody N Brown

(74) *Attorney, Agent, or Firm* — Lucas & Mercanti, LLP;  
Klaus P. Stoffel

(57) **CLAIM**

The ornamental design for a motor vehicle, as shown and described.

**DESCRIPTION**

FIG. 1 is a front, right side perspective view of the motor vehicle of the present invention;  
FIG. 2 is a front, left side perspective view thereof;  
FIG. 3 is a rear, right side perspective view thereof;  
FIG. 4 is a rear, left side perspective view thereof;  
FIG. 5 is a right side view thereof;  
FIG. 6 is a left side view thereof;  
FIG. 7 is a front view thereof;  
FIG. 8 is a rear view thereof;  
FIG. 9 is a top view thereof; and,  
FIG. 10 is a bottom view thereof.

**1 Claim, 8 Drawing Sheets**





Fig. 1



Fig. 2



Fig. 3



Fig. 4

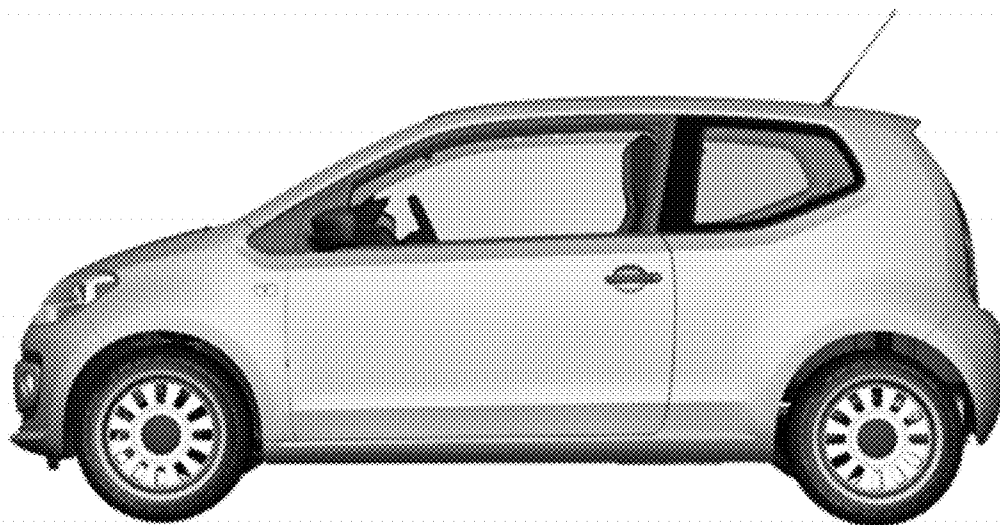

Fig. 5



Fig. 6



Fig. 7



Fig. 8



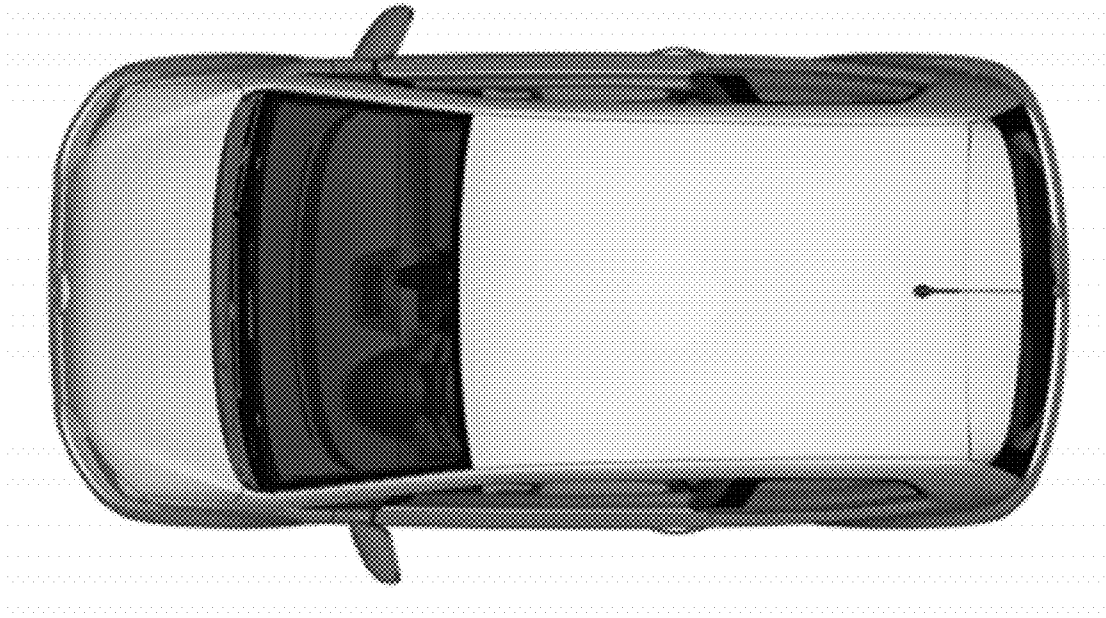

Fig. 9

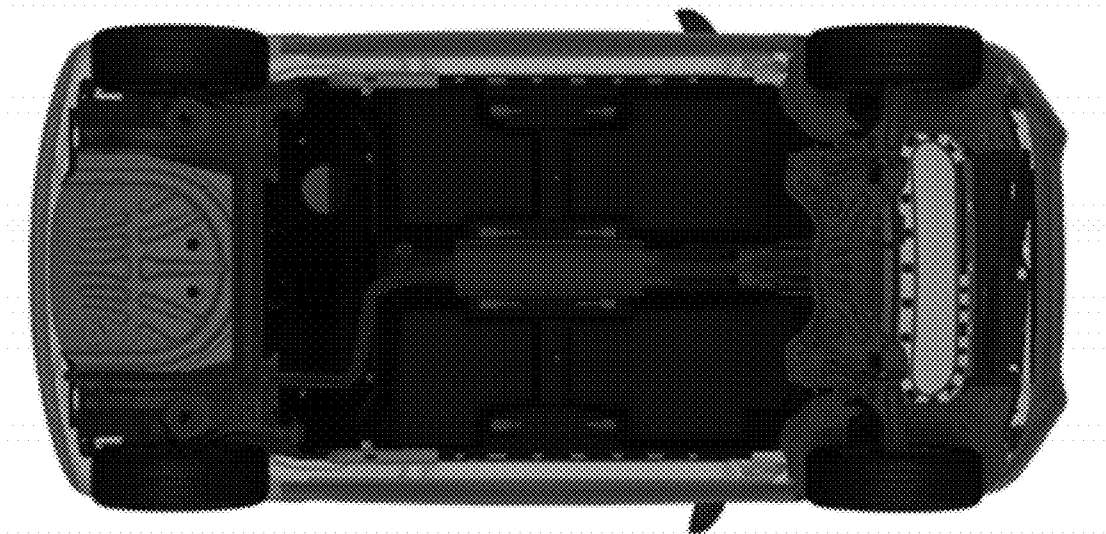

Fig. 10